

Marcin ŁUSZCZYK*
Leszek RAFIŃSKI**

A MEASUREMENT SYSTEM FOR CHILDREN ENDURANCE TESTS

There are a lot of ethical problems concerning the use of invasive methods for the measurement of a child's body response to physical exercise and physical training. The alternative is are non-invasive methods like ergospirometry or NIRS. The article presents a measurement system dedicated for children endurance tests, composed of a few non-invasive measurement modules, including a temperature measurement module. Temperature is one of the factors determining the hemoglobin oxygenation, which in turn determines the physical exercise ability. The system was tested on a group of 15 healthy children 14-16 years old partaking in a ramp exercise test up to exhaustion. The test results are shown in the article.

1. INTRODUCTION

The response of adult organism to physical exercise and physical training is well documented. The same, however cannot be said about children. This situation is the result of the ethical problems of measuring a child's body response. For example invasive methods, like for example taking a blood sample right after exercise, are discouraged. These ethical problems make the measuring process difficult.

Judging by the results of various studies [1, 2, 3] children cannot be treated as 'mini-adults'. A child's reaction to incremental exercise can be different from the reaction of an adult. Williams [2] suggests that the limitations of data extrapolated from adults are acknowledged and in all cases it is emphasized that recommendations and implemented practice should be based on data collected from young people. In a review paper by Hamaoka [4] the progress, especially in the last decade, that has been made in evaluating skeletal muscle oxygenation and oxidative energy metabolism in sports, health and clinical sciences is highlighted. However there are very few published data on the issue concerning healthy children [5, 6].

One of the non-invasive techniques, that can be used for measuring children response during physical tests is the near-infrared spectroscopy (NIRS). The technique has been shown to be one of the tools that can measure oxygenation in muscle and other tissues in vivo [4, 10].

* Jędrzej Sniadecki University of Physical Education and Sport.

** Gdańsk University of Technology.

A great deal of important information concerning the integrated pulmonary–cardiovascular–muscle metabolic response to exercise can be acquired from the breath-by-breath measurement of pulmonary gas exchange (PGE) during ramp incremental exercise tests. This procedure permits not only the determination of the peak VO_2 (which is generally considered to be the ‘gold-standard’ measurement for the assessment of aerobic fitness), but also estimates of ‘delta efficiency’ (from the slope of the relationship between VO_2 and work rate) and the lactate threshold (from the associated non-linear responses of VCO_2 and VE). Derived PGE variables are useful not only in the evaluation of exercise capacity in athletes and healthy volunteers but also in defining the physiological limitations to exercise performance in disease. Furthermore, the breath-by-breath measurement of PGE in the abrupt transition from rest (or, more often, very light exercise) to a higher constant work rate can provide important information on the dynamic adjustment of oxidative metabolism following a “step” increase in metabolic demand. The rate at which VO_2 rises (i.e. the VO_2 kinetics) during such exercise is another parameter of aerobic fitness, which is relevant both in health and disease and which can also be used to differentiate central versus peripheral limitations to exercise performance.

The authors decided to add temperature measurement to the standard measurement techniques when designing the measurement system. Body temperature is another parameter that differs children and adults. The physical as well as physiological differences between children and adults may explain the different response to thermal stress [7], but there is also research showing contrary results [8]. The major reasons for the discrepancy are that the authors have not qualified their conclusions to the specific ambient conditions that prevailed during their experiments. While the most apparent thermoregulatory-related difference between children and young adult is the lower overall sweating rate by children seems to be the most apparent difference between young adults and older individuals. Both may be accompanied by a greater rate of increase in body temperature and reduced heat tolerance in both children and the elderly [8].

According to literature, temperature is one of the factors determining the hemoglobin oxygenation, which in turn determines the physical exercise ability [7].

2. THE MEASUREMENT SYSTEM

The purpose of the measurement system was the determining the relation between a few chosen ergospirometric parameters, brain tissue oxygenation and body temperature during endurance tests for children. Taking that and the limitations when it comes to measuring children the following system was designed.

As there is a lot of different information that needs to be collected during an endurance test, the system was divided into five basic modules:



- ergometer,
- spirometer,
- heart rate monitor,
- spectrophotometer,
- temperature monitor.

The Ergoline Ergoselect VIA Sprint 150 P was selected as the chosen ergometer for the system. It is a cycle ergometer, that has a built in magnetic brake and a rotational speed measurement module. Also, there is a serial interface provided, which allows for the brake to be controlled by a computer system.

Viasys Oxycon Pro is the chosen spirometer. A spirometer allows for the measurement of the concentration of oxygen and carbon dioxide in exhausted air, as well as the volume of the exhausted air. It is composed of a base station connected to a PC and a measurement module, in the form of a mouthpiece, which the tested person should be breathing thru.

The volume of the exhausted air is computed based on the speed of the exhausted air measured by means of a thermal anemometer built in the measurement module. According to the producer, the maximum error of the measurement is 50 ml.

The oxygen concentration is measured using an electro-galvanic fuel cell. A chemical reaction occurs in the fuel cell when the anode comes into contact with oxygen. This creates an electric current between the anode and cathode through a load resistance. The current produced is proportional to the concentration (or partial pressure) of oxygen in the tested air. According to the producer, the maximum error of the measurement is 3%.

The carbon dioxide concentration is measured using an infrared sensor. The infrared light is directed through the air towards the a detector. Gas concentration is computed based on the measured absorption of a specific wavelength in the infrared. According to the producer, the maximum error of the measurement is 3%.

For the heart rate monitor the Polar T31 Coded was chosen. It is composed of a wireless sensor, that communicates with a PC using the bluetooth interface. The sensor is built in a chest strap. The measurement principle is the same as in electrocardiography – the device detects and amplifies the tiny electrical changes on the skin that are caused when the heart muscle depolarizes during each heartbeat.

Hamamatsu Photonics NIRO-200 is the chosen spectrophotometer. The device is a two channel tissue oxygenation monitor that uses near infrared spectroscopy. It was designed as a tool for measuring brain tissue oxygenation of patients during medical procedures. Using the Beer-Lambert law and the measured absorption factor of the tested tissue the device can compute the concentration of oxygenated (ΔO_2Hb) and deoxygenated (ΔHHb) hemoglobin as well as the total hemoglobin concentration (ΔcHb) in a tissue. It should be noted that the device does not show actual hemoglobin volume, but the shown levels are a factor of the baseline level



defined by the user at the start of a measurement. The maximum frequency of the measurement is 6 Hz.

The original purpose of the NIRO-200 device makes it hard to execute some of the measurements needed during an endurance test. The two sensors provided are designed to be mounted on the forehead of a patient, which makes them hard to use on moving limbs, as they constantly fall down. Also, it should be noted that there is no evidence that the measurements of moving muscles are as accurate as those of the 'stationary' tissues.

The temperature measurement module was designed and constructed at the Chair of Metrology and Information Systems, Gdańsk University of Technology. The module consists of the NI USB-6008 data acquisition device, two temperature sensors using thermistors and the developed software.

The temperature measurement module contains two equal sensors. The schematic of one of them is shown on Fig. 1.

The temperature is measured indirectly by measuring the resistance of the thermistor R_1 . This means that the uncertainty of the measurement $u(R_T)$ depends on the uncertainty of the resistance measurement $u(R_1)$ and the uncertainty of the thermistor workmanship $u(R_t)$, which leads to the following equation:

$$u(R_T) = \sqrt{u^2(R_t) + u^2(R_1)} \quad (1)$$

According to the producer the maximum workmanship error of the thermistor ΔR_1 is 1%. Assuming uniform distribution [9]:

$$u^2(R_t) = \left(\frac{\Delta R_1}{\sqrt{3}}\right)^2 = 3333,33 \quad \Omega^2 \quad (2)$$

According to the schematics on image 2.1, the resistance R_1 can be calculated:

$$R_1 = \frac{U_{wy} R_2 R_3}{UR_2 - U_{wy} R_2 - U_{wy} R_3} \quad (3)$$

The uncertainty of the resistance measurement $u^2(R_1)$ depends on the workmanship uncertainty of resistors R_2 and R_3 ($u(R_2)$ and $u(R_3)$), the uncertainty of the voltage source U ($u(U)$) and the uncertainty of the measurement of the U_{wy} voltage ($u(U_{wy})$). Assuming those variables are uncorrelated:

$$u(R_1) = \sqrt{\left(\frac{\partial R_1}{\partial R_2}\right)^2 u^2(R_2) + \left(\frac{\partial R_1}{\partial R_3}\right)^2 u^2(R_3) + \left(\frac{\partial R_1}{\partial U}\right)^2 u^2(U) + \left(\frac{\partial R_1}{\partial U_{wy}}\right)^2 u^2(U_{wy})} \quad (4)$$



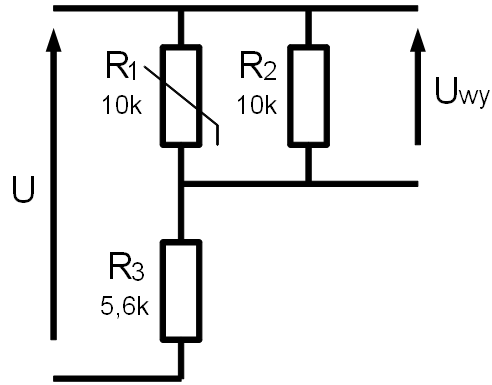

Fig. 1. Schematic of the measurement module sensor

According to the producer the maximum workmanship error of the resistors used is 0,1%. Assuming uniform distribution:

$$u^2(R_2) = \left(\frac{\Delta R_2}{\sqrt{3}}\right)^2 = 33,33 \quad \Omega^2 \quad (5)$$

$$u^2(R_3) = \left(\frac{\Delta R_3}{\sqrt{3}}\right)^2 = 10,45 \quad \Omega^2 \quad (6)$$

The voltage U is provided by one of the NI USB-6008 analog outputs, for which the absolute accuracy is defined as $AA_{OUT} = 36,4$ mV. Assuming uniform distribution:

$$u^2(U) = \left(\frac{AA_{OUT}}{\sqrt{3}}\right)^2 = 4,42 \cdot 10^{-4} \quad V^2 \quad (7)$$

The voltage U_{wy} is measured using one of the NI USB-6008 analog inputs, for which the absolute accuracy is defined as $AA_{IN} = 4,28$ mV. Assuming uniform distribution:

$$u^2(U_{wy}) = \left(\frac{AA_{IN}}{\sqrt{3}}\right)^2 = 6,11 \cdot 10^{-6} \quad V^2 \quad (8)$$

In accordance with the above equations, the uncertainty of the measurement $u(R_T)$ is:

$$u(R_T) = 342,99 \quad \Omega \quad (9)$$

Assuming 95% level of confidence:

$$U(R_T) = 2u(R_T) = 685,98 \quad \Omega \quad (10)$$



3. TEST

Fifteen healthy right-handed children (mean \pm SD: 15,9 \pm 1,38 yr old; 11,6 \pm 7,48 % FAT; 60,1 \pm 9,84 kg FFM; 53,0 \pm 9,71 kg body mass; 1,75 \pm 8,31 m stature; 52,6 \pm 8,37 mL \cdot min⁻¹ \cdot kg⁻¹ VO_{2max}, 79,0 \pm 4,51 %VO_{2max} ventilatory anaerobic threshold). All subjects were well-trained table tennis competitors (7,9 \pm 1,1 years of training, 4,7 h \cdot week⁻¹). They had no history of cardiovascular, respiratory, endocrinological, musculoskeletal or neurological disorders, and were free of medication. Subjects were requested to refrain from training for two days prior to testing. Before the beginning of the study, ethical approval of procedures and the informed consent of both the children and their parents were obtained.

The test aimed to determine maximal oxygen uptake (VO_{2max}). The participants were allowed to sit quietly on the cycle ergometer for 2 min to collect baseline cardiorespiratory and NIRS measurements. Subjects performed a 5 min warm-up at 1.5 W \cdot kg⁻¹. The test consisted of a ramp exercise test up to exhaustion to determine their VO_{2max} using a ramp rate of 25 W \cdot min⁻¹. During the whole test, the children were instructed to maintain a cycling speed of 55 rpm. Subjects were resting in a sitting position during a 5 min recovery period.

It was judged that subjects had reached VO_{2max} when 3 or more of the following criteria were obtained: an inability to maintain the required pedaling cadence, a maximal heart rate > 90% of predicted maximal heart rate (220-age), a plateau in VO₂ despite increasing power (VO_{2change} < 2.0 ml \cdot kg⁻¹ \cdot min⁻¹), and a final respiratory exchange ratio (RER) higher than 1.0.

The first pair of optodes of the NIRO-200 device was placed over the left frontal lobe (1 cm above the eyebrow and 1 cm to the left of the skull centre) of the subjects for cerebral hemodynamic monitoring. The second pair was positioned on the medial line of the right vastus lateralis along the vertical axis of the muscle, one third of the distance from the lateral epicondyle to the greater trochanter of the femur. Both of the probes were covered with a piece of black plastic wrap and was held in place using double adhesive tape and a tensor bandage. The temperature sensors were placed 0.5 cm away from the optodes using adhesive tape and a bandage.

The test results are shown on Fig. 2. The system allowed for the measurement of critical endurance tests data, as well as temperature.

The results suggest, that the hemoglobin oxygenation in the frontal lobe area (O₂Hb) is related to the increasing load, but after the ventilatory anaerobic threshold (VAT) the relation becomes non-linear. This has been shown earlier in [10], where the authors distinguish 3 different phases of brain tissue oxygenation in response to increasing physical exercise (linear oxygenation, hyper-oxygenation and desaturation).



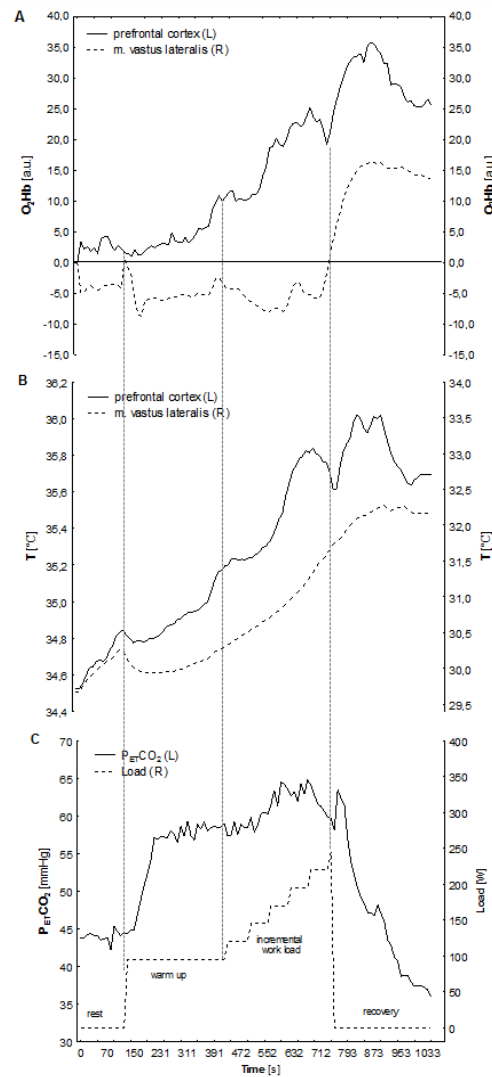

Fig. 2. Curve response of a representative subject: (A) oxygenated hemoglobin/myoglobin (O₂Hb) in prefrontal cortex (continuous line – left axis) and vastus lateralis muscle (dotted line – right axis); (B) skin temperature in frontal lobe area (continuous line – left axis and skin temperature in muscle area (dotted line – right axis); (C) end-tidal carbon dioxide pressure (P_{ET}CO₂) – continuous line (left axis) and work load (W) – dotted line (right axis).

The relation between brain tissue oxygenation (O₂Hb), carbon dioxide pressure (P_{ET}CO₂) and frontal lobe skin temperature is worth noticing. The temperature is rising till the maximum load is reached, continued exercise leads to its lowering. A similar effect has been shown in [11], at the last phase of a 20 min exercise.

4. CONCLUSION

The designed system allows for the measurement of critical data during children endurance tests using only non-invasive methods.

The relation between skin temperature and hemoglobin oxygenation may lead to an assumption that the temperature changes, monitored in real time, are a possible factor in determining the maximum intensity of an exercise, especially for children endurance tests. This assumption requires further investigation.

REFERENCES

- [1] Falk B., Dotan R., Child-adult differences in the recovery from highintensity exercise. *Exercise and Sport Science Reviews*, 2006, 34: 107-12. (in English).
- [2] Williams C., Environmental factors affecting elite young athletes. *Medicine and Sport Science*, 2011, 56: 150-70. (in English).
- [3] Dotan R., Mitchell C., Cohen R., Gabriel D.A., Klentrou P., Falk B., Child-Adult Differences in the Kinetics of Force Development. In: *The First Wingate Congress of Exercise & Sport Sciences*, Wingate Institute, Israel, 2010: 114. (in English).
- [4] Hamaoka T., McCully K.K., Niwayama M., Chance B., The use of muscle near-infrared spectroscopy in sport, health and medical sciences: recent developments. *Philos Transact A Math Phys Eng Sci.*, 2011, 28; 369 (1955): 4591-604. (in English)
- [5] Kawakubo Y., Kono T., Takizawa R., Kuwabara H., Ishii-Takahashi A., Kasai K., Developmental changes of prefrontal activation in humans: near-infrared spectroscopy study of preschool children and adults. *PLoS One.*, 2011, 6 (10): e25944. (in English).
- [6] Łuszczczyk, M., Kujach, S., Olek, R.A., Laskowski, R., Szczęsna-Kaczmarek, A., Prefrontal cortex oxygenation and muscle oxygenation during incremental exercise in children: A near-infrared spectroscopy study. In Armsrtong N, Williams C (eds.) *Children and Exercise XXVI*, Oxford: Routledge, 2012, 83-89. (in English).
- [7] Falk B., Effects of thermal stress during rest and exercise in the paediatric population. *Sports Medicine*, 1998, 25 (4): 221-40. (in English).
- [8] Inbar O., Morris N., Epstein Y., Gass G., Comparison of thermoregulatory responses to exercise in dry heat among prepubertal boys, young adults and older males. *Experimental Physiology*, 2004, 89 (6): 691-700. (in English).
- [9] Evaluation of measurement data – Guide to the expression of uncertainty in measurement JCGM 100:2008, GUM 1995. (in English).
- [10] Timinkul A., Kato M., Omori T., Deocarís C.C., Ito A., Kizuka .T, Sakairi Y., Nishijima T., Asada T., Soya H. Enhancing effect of cerebral blood volume by mild exercise in healthy young men: a near-infrared spectroscopy study. *Neuroscience Research*, 2008, 61(3): 242-8. (in English).
- [11] Inbar O., Morris N., Epstein Y., Gass G., Comparison of thermoregulatory responses to exercise in dry heat among prepubertal boys, young adults and older males. *Experimental Physiology*, 2008, 89.6: 691-700. (in English).