

A Model-Based Improved Control of Dissolved Oxygen Concentration in Sequencing Wastewater Batch Reactor

Karol BŁASZKIEWICZ, Robert PIOTROWSKI, Kazimierz DUZINKIEWICZ

Gdansk University of Technology, Faculty of Electrical and Control Engineering,
Narutowicza 11/12, 80-233 Gdansk, Poland,

karolblaszkiewicz@gmail.com, r.piotrowski@eia.pg.gda.pl, k.duzinkiewicz@eia.pg.gda.pl

Abstract: Biochemical processes at wastewater treatment plant are complex, nonlinear, time varying and multivariable. Moreover, relationships between processes are very strong. One of the most important issues is exerting proper control over dissolved oxygen levels during nitrification phase. This parameter has a very large impact on activity of microorganisms in activated sludge and on quality of pollution removal processes. Oxygen is supplied by aeration system which consists of many nonlinear elements (blowers, pipes, diffusers). In this paper, the sequencing batch reactor is applied and modelled. Also, the aeration system is modelled. Those models are validated based on real data sets. The adaptive control system with anti-windup filter is proposed and designed for tracking the reference trajectory of dissolved oxygen. Furthermore, the reference trajectory of dissolved oxygen is generated by the supervisory controller using NH_4 measurements. Simulation results of control system are calculated for a case study plant located in Swarzewo, Northern Poland.

Keywords: aeration, adaptive control, cascade control, dissolved oxygen, nonlinear control, wastewater treatment.

1. Introduction

Progressive development of technology and human population growth caused the amount of produced sewage to increase. Years of experience and scientific research, gave rise to the idea about biological wastewater treatment plants (WWTP). This biological-chemical-physical system is classified as complex, multivariable, time varying and nonlinear.

In industrial practice, two different types of WWTPs are used: sequencing batch reactor (SBR) and WWTP with a continuous flow throughout the plant. In this paper the SBR type of the WWTP was considered.

The SBR technology is widely used for small wastewater inflows and may be designed using a single or multiple tanks in parallel. A typical cycle involves five operational phases: filling, reactions (nitrification and denitrification), sedimentation, decantation and idle state. Biochemical reactions in SBR were described in detail in e.g. [1]. In [2] a complete review of experiences using SBR of different kinds is presented.

One of phases taking place in a SBR reactor is the nitrification phase. This stage has a very large impact on removal pollutions. The most important control parameter in this phase is the concentration of dissolved oxygen (DO). Improvement of oxygen level control in the

reactor could increase quality of outflow and decrease incurred operating costs. The dynamics of DO is nonlinear. Hence, high quality control for all operating conditions can be hard to achieve by using simple control strategies, e.g. on/off control system, linear PID controller with fixed parameters.

Previous studies reported various structures and technologies of DO control system, e.g. predictive controller [3,4,5,6,7], multivariable PID controller [8,9], neural and fuzzy controllers [10,11]. Other DO control strategies using NH_4 , NO_3 and PO_4 measurements have been designed and tested, e.g. [12,13]. In most cases, the nonlinear dynamic of aeration system is omitted and treated as static element. However, this system is very complex and contains many nonlinear elements, e.g. blowers, pipes and diffusers. In this paper, as opposite of previous research works, nonlinear dynamic of aeration system is coupled with biological processes. Furthermore, beside DO measurement, NH_4 measurement is included for control system design.

The paper was organized as follows. The Swarzewo WWTP case study was described in Section 2. The aeration system was presented in Section 3. Design of control system was described in Section 4. Section 5 presents results of simulations and discussions. Conclusions were included in Section 6.

2. Wastewater Treatment Plant – Description and Modelling

WWTP in Swarzewo is a typical plant using the SBR technology. The average waste output of the WWTP is about 6000 m³/day. Figure 1 shows the plant schematically.

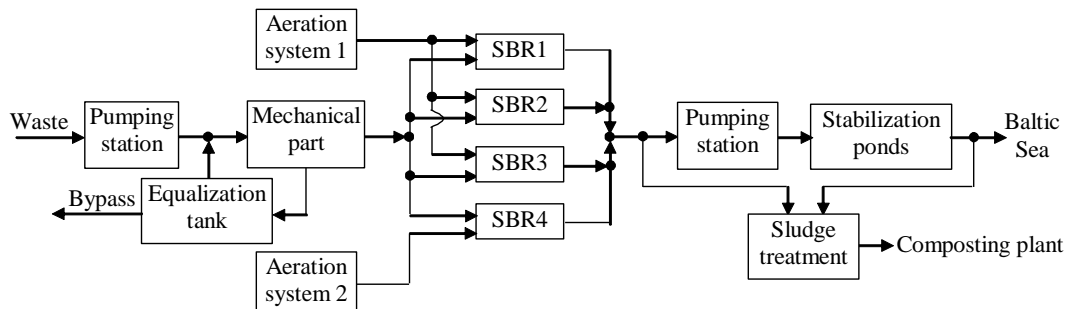

Figure 1. Technological scheme of the Swarzewo WWTP.

Purification of sewage solids and mineral is achieved through mechanical pre-treatment. This first phase uses by grid, screen, grit chamber and sand separator. In the second phase a biological pollutant removal is performed by four SBRs. Three reactors have the same volume of 5100 m³. The fourth SBR is about 6400 m³. The SBRs work in parallel and independently of each other. A single SBR cycle includes the following phases: filling, reactions (nitrification and denitrification), sedimentation, decantation and idle state. The excess sludge is removed and in the form of compost used as a garden soil. The Baltic Sea is the effluent receiver. In this paper the biological part of WWTP was considered and modelled.

Air supply for each reactor is provided by two identical and independent aeration systems. The first of these aerate SBR1, SBR2 and SBR3. The second installation (aeration system 2) is dedicated for SBR4. A structure based on SBR4 and aeration system 2 was considered in this paper. The most popular mathematical description of biological processes at WWTP is a series defined by Activated Sludge Models (ASM) proposed by International Water Association. In the paper the biological processes are modelled by ASM2d model. ASM2d consists of 21 state variables and 20 kinetic and stoichiometric parameters. Values of those parameters are equal to their default values at 20°C [14]. ASM2d model was calibrated based on real data sets from WWTP

at Swarzewo. Additionally, data from the plant permitted to define the quality of load: chemical oxygen demand (COD), total nitrogen concentration (N_{tot}) and total phosphorous concentration (P_{tot}). Verification of the modelling results was satisfactory and so they were used for control purposes.

3. Aeration System – Description and Modelling

It is industry practice that different methods of aeration are used: high purity oxygen aeration, mechanical aeration or diffused aeration. In Swarzewo WWTP the last method is applied. Aeration system 2 supplies the SBR4 in oxygen by compressed air (see Figure 1). This system consists of two blowers, main pipe (collecting pipe), two collector-diffuser pipes and two diffuser systems (see Figure 2).

Two identical variable-speed blowers with inverters were used. The blowers work in parallel. Actual airflow through the blower depends on the pressure drop across and rotational speed of rotor. Static characteristics of blowers are nonlinear.

The diffuser system is composed of a number of diffusers in parallel arrangement located in the reactor bottom floor and connected through a network of secondary pipes to the collector-diffuser pipe. Diffusers are the membrane disk type. Diffuser system 1 contains 616 diffusers, diffusers system 2: 600 diffusers. A single diffuser is described by the nonlinear relationship between airflow and pressure drop across. Diffusers are located 0.35m above the bottom of reactor.

The general methodology of aeration system modelling was presented in [5]. This approach was applied in modelling others plants, e.g. [5,6,7]. Model of the Swarzewo

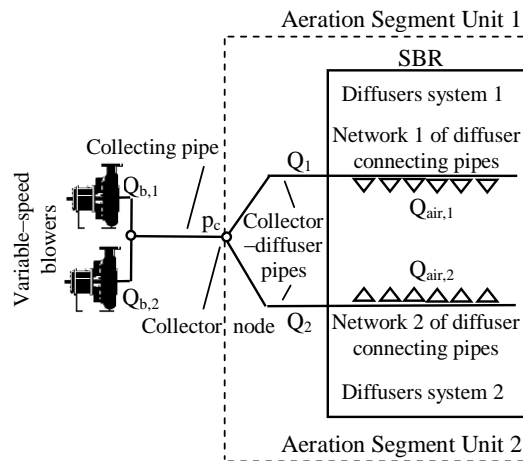

Figure 2. Structure of the Swarzewo aeration system.

aeration system was first presented in [15]. The authors used data records from a case study plant, documentation concerning characteristics of system elements and theoretical knowledge. Very good results of model verification were obtained.

Finally, the nonlinear model was described by differential and algebraic equations [15]. The model of aeration system was implemented in Matlab environment and was verified based on real data records from Swarzewo WWTP. The maximum pressure residuum was around 2%, while the maximum airflow residuum was about 7%. Satisfactory accuracy was obtained.

4. Control System – Structure and Design

It is industry practice that simple technology is used to control of DO: manual control, rule-based control and PI controller with fixed parameters. High quality of control cannot be obtained by conventional and linear control methods. The structure of the new control system is illustrated in Figure 3.

Control plant consists of an ASM2d model, which represents biochemical processes taking place in the SBR reactor (see section 2) and model of an aeration system (see section 3). This approach means that considered plant has many physical bounds and dynamics with different time scales. Blowers have technological limitations imposed on realized airflow and rotational speed of the rotor. Additionally dynamics of aeration system and processes in the reactor are different. Testing proved that internal dynamics of the aeration system (about 20 seconds) is much faster than biochemical reactions taking place within the SBR.

4.1 Static airflow controller

In order to achieve desired level of DO, the aeration system must provide the required amount of air. This condition is very important because airflow is a direct signal control. Hence, the static airflow controller is located in direct control layer of hierarchical control structure (see Figure 3). Dynamics of aeration system are slower than SBR dynamics and for control purposes dynamics of aeration system

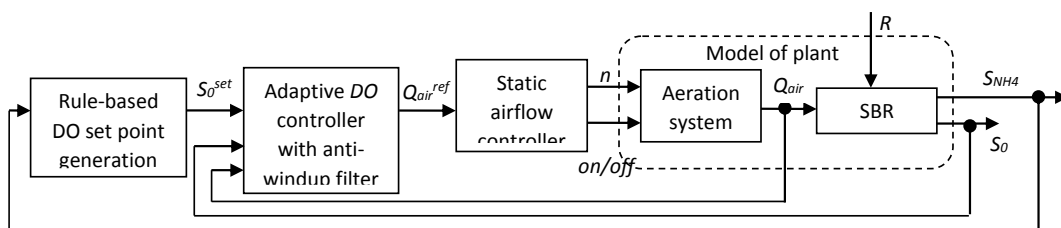

Figure 3. Structure of the new control system.

were omitted. Because of this the airflow controller based on inverse model of aeration system was proposed – Inverse Model Control (IMC) [16]. Input to the controller is a set point of airflow Q_{air}^{ref} . Outputs are rotational speed of blowers n and state (switching) on/off the blowers. An important aspect of IMC is static characteristics of blowers, which had to be inversed in order to achieve desired relationship between the rotational speed of blowers and their airflow. Knowledge about airflow set point Q_{air}^{ref} and inverse characteristics permits to generate desired control signals (n , on/off).

4.2 Adaptive DO controller with anti-windup filter

Direct adaptive controller with reference model (DMRAC) was designed for the second control loop. Moreover, it was expanded by anti-windup (AW) filter. The desired plant response is defined by response of the reference model. Furthermore, the AW filter reduces the impact of control signal limitations. Equations (1)-(2) describe model of DO used for control purposes. Designed control loop adjusts oxygen levels so only reactions which describe the nitrification phase were used.

$$\frac{dS_o(t)}{dt} = k_{La}(Q_{air}(t)) \cdot (S_o^{sat} - S_o(t)) - \frac{S_o(t)}{K_o + S_o(t)} \cdot R(t) \quad (1)$$

$$k_{La}(Q_{air}(t)) = \alpha \cdot Q_{air}(t) \quad (1a)$$

$$\frac{dS_o(t)}{dt} = \alpha \cdot Q_{air}(t) \cdot (S_o^{sat} - S_o(t)) - \frac{S_o(t)}{K_o + S_o(t)} \cdot R(t) \quad (2)$$

where: $S_o(t)$, $k_{La}(Q_{air}(t))$, $R(t)$ is concentration of oxygen, function of oxygen transfer and respiration, respectively. Parameters K_o , $S_o^{sat} = 8.64 \text{ mg/dm}^3$ and $\alpha = 0.0016 \text{ 1/m}^3$ are Monod's constant, DO concentration saturation limit and directional factor of $k_{La}(Q_{air}(t))$, respectively. The value of α is defined by Simba environment [17].

Dynamics of DO have three primary properties: non-linearity, non-stationarity and dependence of disturbance (respiration R). The value of Monod's constant K_o may be varied within the range from 0.01 to 2 g/m^3 (the assumed value is

equal 2 g/m^3). This coefficient causes non-stationarity of DO dynamics. Furthermore, K_o occurs in fraction $\frac{S_o}{K_o + S_o} \cdot R$ so this parameter increases non-linearity of the equation (11). Moreover, impact of disturbances as respiration R was shown. Adaptive controller generates control signal Q_{air}^{ref} which reduces the influence of properties and let's achieve dynamics of the reference model.

Formula (3) describes the general form of equation (2).

$$\frac{dx}{dt} = b \cdot u - f(x) \cdot c(t) \quad (3)$$

$$\text{where: } x = S_o(t), \quad b = \alpha \cdot (S_o^{sat} - x), \\ u = Q_{air}, \quad f(x) = \frac{S_o(t)}{K_o + S_o(t)}, \quad c = R(t)$$

The reference model is the inertia of the first order with static gain K and time constant T . The value of K was selected that in the steady state output from the plant would equal output from the reference model. This is true for $K=1$. Parameter T was fixed at 1.25 minute. Transfer function and differential equations which describe dynamics of the reference model are expressed by equations (4)-(5).

$$G(s) = \frac{K}{T \cdot s + 1} = \frac{X^{ref}(s)}{X^{set}(s)} \quad (4)$$

$$\frac{dx^{ref}(t)}{dt} = -\frac{1}{T} \cdot x^{ref}(t) + \frac{K}{T} \cdot x^{set}(t) \quad (5)$$

where: $x^{ref}(t) = S_o^{ref}(t)$, $x^{set}(t) = S_o^{set}(t)$ is concentration of oxygen from reference model and set point of dissolved oxygen, respectively. $X^{ref}(s)$ and $X^{set}(s)$ are Laplace transforms of $x^{ref}(t)$ and $x^{set}(t)$, respectively.

The equation (6) expresses proposed control law:

$$u^{DMRAC}(t) = h \cdot f(x, t) + m \cdot x(t) + g \cdot x^{set}(t) \quad (6)$$

where: h , m , g – parameters of adaptive controller, $u^{DMRAC}(t) = Q_{air}^{ref}(t)$ – indirect control signal.

The adaptation laws for controller parameters were designed based on Lapunov stability theory – equations (7) [18].

$$\begin{aligned} \frac{dh(t)}{dt} &= \gamma_1 \cdot e(t) \cdot f(x, t); \\ \frac{dm(t)}{dt} &= \gamma_2 \cdot e(t) \cdot x(t); \\ \frac{dg(t)}{dt} &= \gamma_3 \cdot e(t) \cdot x^{set}(t) \end{aligned} \quad (7)$$

where: $\gamma_1, \gamma_2, \gamma_3$ – coefficients adaptation, $e(t) = x^{ref}(t) - x(t)$ – adaptation error.

Lapunov stability theory guarantees stability of the control loop and provides convergence of the adaptation error to zero for time tending to infinity. According to [18] the required conditions are limitations of controller parameters and error adaptation. Controller parameters are limited by zero from one side and by ideal parameter from the other side. Ideal values (8) are designated by comparison parameters from the model reference equations and parameters from plant equations.

$$\begin{aligned} h_{ideal} &= \frac{c}{b}; \\ m_{ideal} &= \frac{-a^{ref}}{b}; \\ g_{ideal} &= \frac{b^{ref}}{b} \end{aligned} \quad (8)$$

where: $h_{ideal}, m_{ideal}, g_{ideal}$ – ideal values of adaptive controller parameters, c, d – coefficients of equation (3), $a^{ref} = -1/T$, $b^{ref} = K/T$ – coefficients of equation (5).

Adaptation error is limited if output from the plant and the reference model is limited. Output from the plant is also bounded by zero and value S_0^{sat} . The transfer function of reference model is always stability so output from reference model is limited by zero and value $K \cdot x^{set}(t)$ in steady state. Therefore, it is necessary to ensure limitation of $x^{set}(t)$. It is not a problem because $x^{set}(t)$ is always a bounded signal. Integration of equations (7) can be

obtained through explicit dependence on values of control parameters:

$$\begin{aligned} h(t) &= \gamma_1 \cdot \int e(t) \cdot f(x, t) dt + h_0; \\ m(t) &= \gamma_2 \cdot \int e(t) \cdot x(t) dt + m_0; \\ g(t) &= \gamma_3 \cdot \int e(t) \cdot x^{set}(t) dt + g_0 \end{aligned} \quad (9)$$

The parameters h_0, m_0 and g_0 are values at the beginning of process adaptation (when aeration phase started). Their values were assumed to be zero – to restart oxygenating sewage at any time the adaptation process of parameters reruns from the beginning.

Substituting equations (9) for the proposed control law (6) makes the DMRAC controller composed exclusively of integrators. Taking into account constraints of signal control it is possible for the phenomenon of windup to occur. The static AW filter was proposed in structure of DMRAC controller system (see Figure 4).

Where:

$$x^{in}(t) = \begin{bmatrix} \gamma_1 \cdot e(t) \cdot f(x, t) \\ \gamma_2 \cdot e(t) \cdot x(t) \\ \gamma_3 \cdot e(t) \cdot x^{set}(t) \end{bmatrix}^T \quad (10)$$

$$B = \begin{bmatrix} f(x, t) & x(t) & x^{set}(t) \end{bmatrix} \quad (11)$$

$$u(t) = B \cdot \int x^{in}(t) dt \quad (12)$$

$$u(t)^{bounded} = \text{sat}(u(t)) = \begin{cases} u^{max} & \text{if } u(t) \geq u^{max} \\ u(t) & \text{if } u(t) \in (u^{min}, u^{max}) \\ u^{min} & \text{if } u(t) \leq u^{min} \end{cases} \quad (13)$$

$$e_u(t) = u(t) - u(t)^{bounded} \quad (14)$$

$$K_{AW} = \begin{bmatrix} K_h & K_m & K_g \end{bmatrix} \quad (15)$$

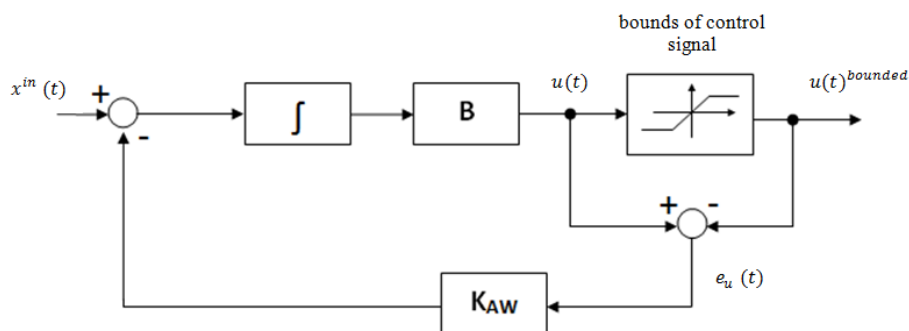

Figure 4. Anti-windup filter in structure of DMRAC.

Table 1. Characteristics of the SBR cycle.

Phase i	Phase i+1	Condition of transition from phase i to phase i+1	Flow in phase i
Filling	Denitrification	$V_s \geq V_{s,max}$ or after 180 minutes	17 000 m ³ /d ≈ 708 m ³ /h
Denitrification	Nitrification	$S_{NO_3} \leq 1 \text{ mg/dm}^3$	–
Nitrification	Sedimentation	$S_{NH_4} \leq 1 \text{ mg/dm}^3$	–
Sedimentation	Decantation	after 90 minutes	–
Decantation	Removal of excess sludge	$V_s \leq V_{s,min}$	24 528 m ³ /d ≈ 1022 m ³ /h
Removal of excess sludge	Filling	after 5 minutes	3024 m ³ /d = 126 m ³ /h

Signals $u(t)$, $u(t)^{bounded}$ and $e_u(t)$ are scalars. Expression (6) of control signal $u(t)$ describes a DMRAC loop without the AW filter. Parameters u^{max} and u^{min} represent upper and lower limits applied to the control signal. The matrix K_{AW} defines filter gains for each of the three integrating circuits. Those parameters must be tuned. Adaptive controller with AW filter has 7 parameters which values must be defined: 3 coefficients adaptation $\gamma_1, \gamma_2, \gamma_3$, time constant of reference model T and 3 gains AW filter (K_h, K_m, K_g).

4.3. Rule-based DO set point generation

Designed rule base generates *DO* set point relationships with the actual concentration of ammonia nitrogen S_{NH_4} – equations (16).

$$\begin{aligned}
 & \text{IF } S_{NH_4} \geq 30 \frac{\text{mg}}{\text{l}} \text{ THEN } S_o^{zad} = 3 \frac{\text{mg}}{\text{l}} \\
 & \text{IF } \left(S_{NH_4} < 30 \frac{\text{mg}}{\text{l}} \text{ AND } S_{NH_4} \geq 20 \frac{\text{mg}}{\text{l}} \right) \\
 & \quad \text{THEN } S_o^{zad} = 2.5 \frac{\text{mg}}{\text{l}} \\
 & \text{IF } \left(S_{NH_4} < 20 \frac{\text{mg}}{\text{l}} \text{ AND } S_{NH_4} \geq 10 \frac{\text{mg}}{\text{l}} \right) \\
 & \quad \text{THEN } S_o^{zad} = 2 \frac{\text{mg}}{\text{l}} \\
 & \text{IF } S_{NH_4} < 10 \frac{\text{mg}}{\text{l}} \text{ THEN } S_o^{zad} = 1.5 \frac{\text{mg}}{\text{l}}
 \end{aligned} \tag{16}$$

Presented rule base does not guarantee minimization of any quality ratio or operating costs, but provides a variable DO set point trajectory. It is known that the aerobic bacteria demand for oxygen is decreasing over time. Intuitively, it may be concluded that decrease

of DO set point will cause the airflow into the reactor to decrease. The net result is a decrease in operating costs. Subsequent analysis of presented results (see section 5) shows why the rule base was not extended and why no attempts were made to design a more advanced DO set point controller.

5. Simulation Results and Discussions

This section describes testing proposed control strategy by simulation, based on real data records from Swarzewo WWTP. The SBR reactor was implemented in commercial simulation package Simba [17]. MatLab/Simulink environment was used for modelling the aeration system. Next, both models were connected. The adaptive controller was applied in MatLab/Simulink package.

Presented sequence could have a very large impact on control results. Specification for analysis in SIMBA package assumed a single fill-nitrification sequence. Furthermore, parameters at each phase were established based on expert knowledge from a treatment plant technologist (see Table 1). The COD , N_{tot} and P_{tot} are the parameters (disturbances) describing the influent sewage composition defined for each simulation. The presented results were obtained for two cases.

5.1 Case 1 – Influence of aeration system dynamics

Assumptions taken to produce presented results: control system comprises only the DMRAC controller (without AW filter and supervisory rule-based controller); constant

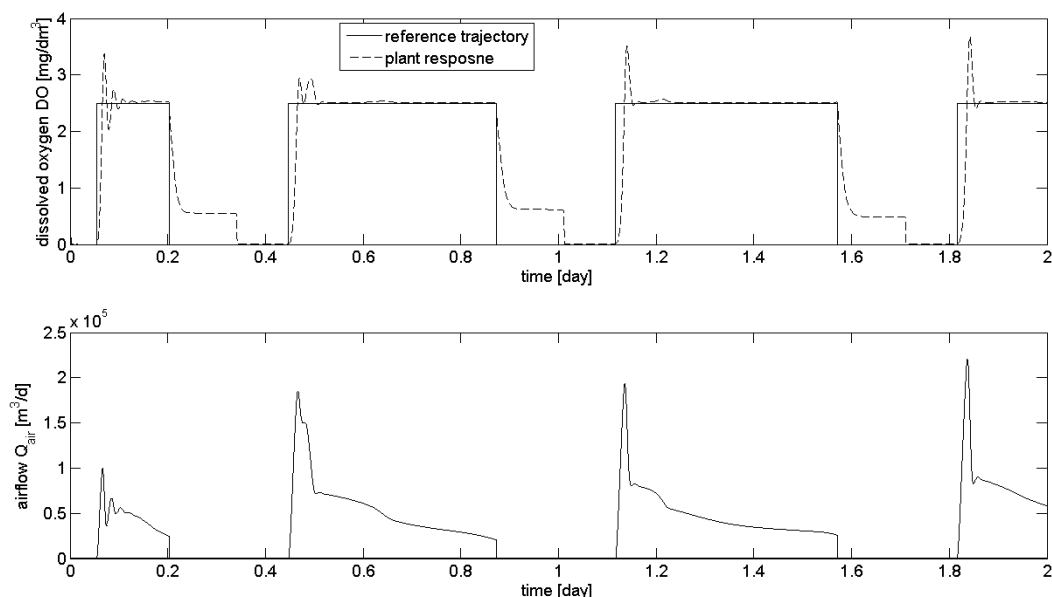

Figure 5. Control results – case 1, without aeration system.

reference trajectory of DO equal 2.5 mg/dm^3 ; parameters of waste influent: $\text{COD}=1074 \text{ mg/dm}^3$, $N_{\text{tot}}=110.3 \text{ mg/dm}^3$, $P_{\text{tot}}=14.7 \text{ mg/dm}^3$; values of controller parameters: $\gamma_1 = 7 \cdot 10^5$, $\gamma_2 = 8 \cdot 10^5$, $\gamma_3 = 9 \cdot 10^5$, $T=1.25 \text{ min}$. Figure 5 presents results for simulation without the aeration system, i.e. control signal feed from controller is perfect. Figure 6 shows a situation where control signal is generated by the aeration system.

Control results were satisfactory (see Figure 5). Obtained quality of control was consistently very good during the nitrification phase. Initial

oscillations were caused by the adaptive nature of controller. Inclusion of aeration system worsened achieved results (see Figure 6). The real limitations of the aeration system cause two phases of control signal saturation – at the beginning and end of the nitrification phase. The **consequences** are bigger oscillations and sudden growth of DO at the end of the nitrification phase.

5.2 Case 2 – Importance of the AW filter

Assumptions taken to produce presented results: control system without supervisory rule-based

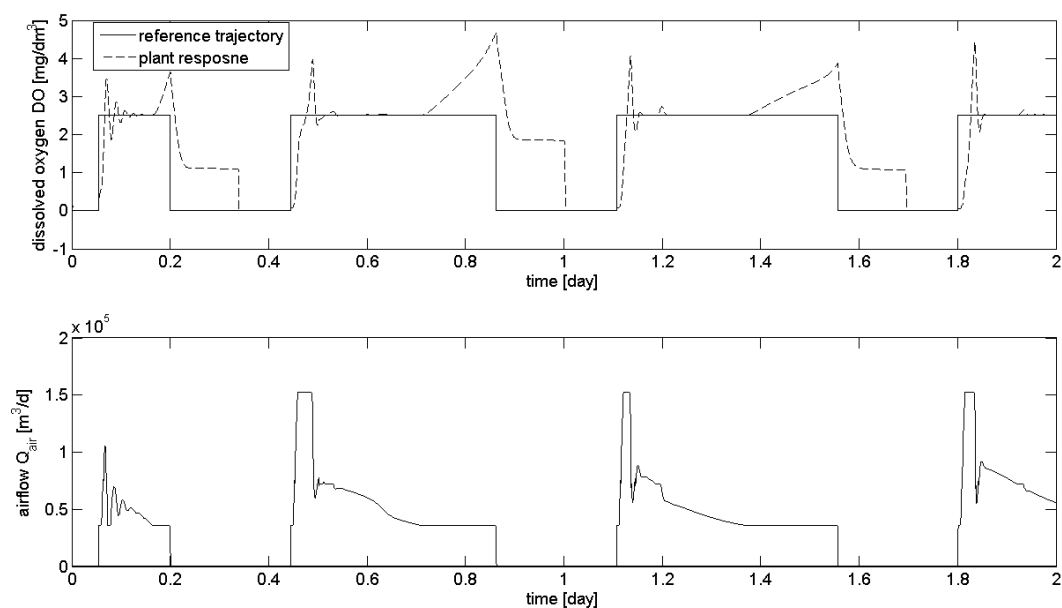

Figure 6. Control results – case 1, with aeration system.

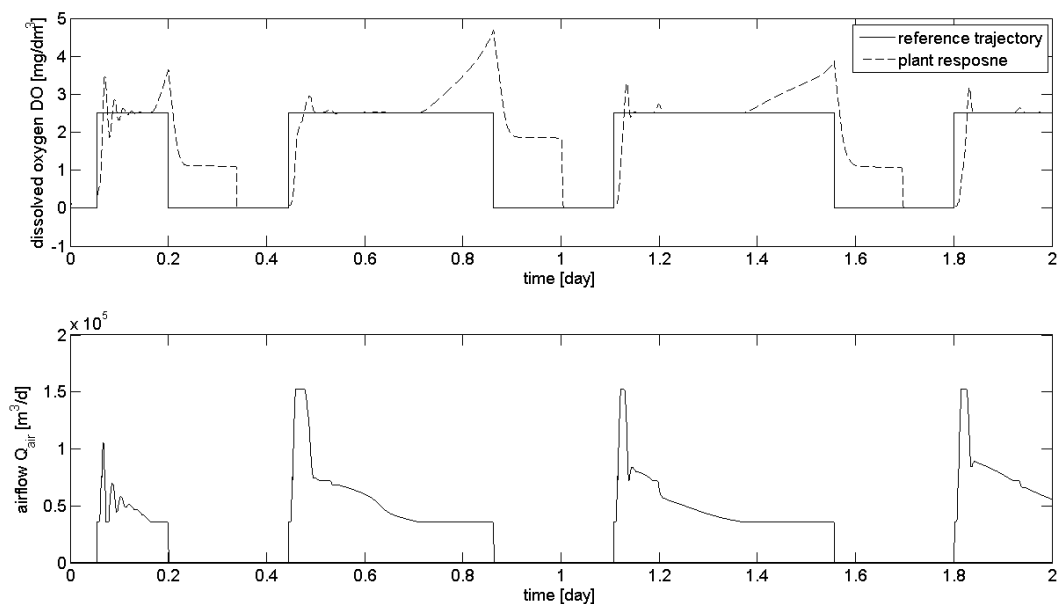

Figure 7. Control results – case 2.

controller; constant reference trajectory of DO equal 2.5 mg/dm³; parameters of waste influent: COD=1074 mg/dm³, N_{tot}=110.3 mg/dm³, P_{tot}=14.7 mg/dm³; values of controller parameters: $\gamma_1 = 7 \cdot 10^5$, $\gamma_2 = 8 \cdot 10^5$, $\gamma_3 = 9 \cdot 10^5$, $T = 1.25 \text{ min}$, $K_h = 4 \cdot 10^4$, $K_m = 12 \cdot 10^4$, $K_g = 4 \cdot 10^4$. Figure 7 shows control results with anti-windup filter.

It may be concluded that the AW filter improves quality of control. For example the overshoot decreased from 76% to 28% for fourth nitrification phase. Unfortunately, the AW filter does not affect saturation of control

signal at the end of nitrification. The cause is sludge's decreasing demand for oxygen – it is not possible that demand for oxygen would grow during the nitrification phase. Consequently it is not possible to unload the integrated value of signal control during the saturation phase.

5.3 Case 3 – Quality of control system

Case 2 presents results for a complete control system with a DMRAC controller using a AW filter and supervisory rule-based controller (see Figure 3). Assumptions taken to produce

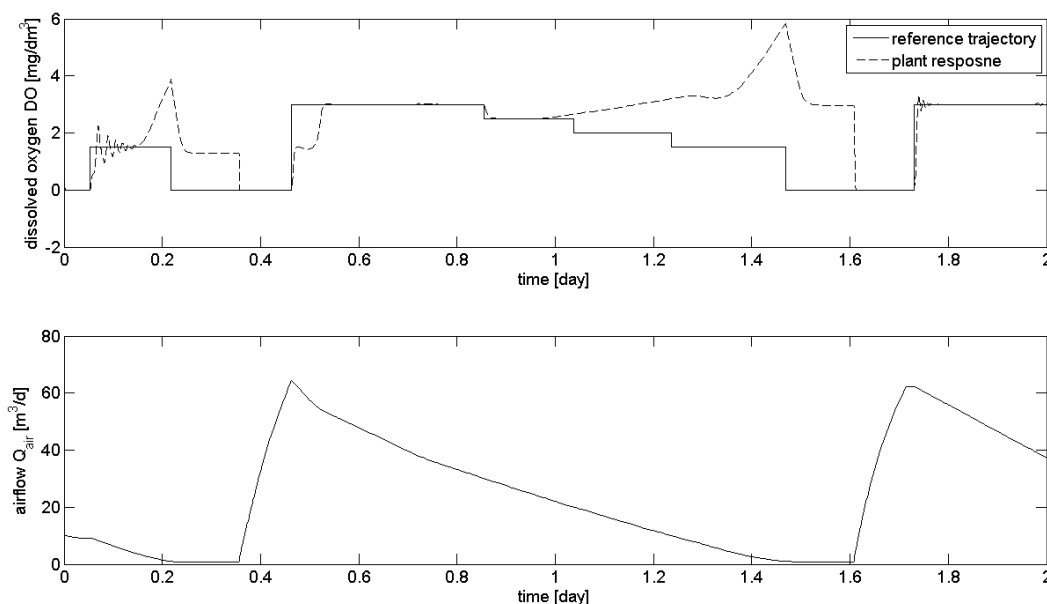

Figure 8. Control results – case 3.

presented results: variable reference trajectory of DO generated by rule-based controller; influent parameters: COD=2032 mg/dm³, N_{tot}=240 mg/dm³, P_{tot}=30 mg/dm³; values of controller parameters: $\gamma_1 = 7 \cdot 10^5$, $\gamma_2 = 4 \cdot 10^6$, $\gamma_3 = 2 \cdot 10^6$, $T = 1.25 \text{ min}$, $K_h = 4 \cdot 10^4$, $K_m = 12 \cdot 10^4$, $K_g = 4 \cdot 10^4$. Presented results (see Figure 8) confirm the control system operates correctly.

The supervisory controller generates a reference trajectory that depends on the actual concentration of NH₄. DMRAC controller with the AW filter produces the DO set point value if the aeration system does not run close to its physical limitations. When control signal becomes saturated, quality of control is worse.

6. Conclusions

This paper discussed tracking the reference trajectory of dissolved oxygen in sequencing batch reactor. The set point for DO controller was generated by the supervisory controller using NH₄ measurements. The aeration system was included in control system structure. It was concluded that dynamics of the aeration system have a very large impact on quality of control and it could not be ignored. Moreover, proper control of each phase is important for final control quality. Simulation results shown that the designed advanced control system achieves good tracking performance if the aeration system does not reach its own technological limitations.

REFERENCES

1. WILDERER, P. A., R. L. IRVINE, M. GORONSZY, **Sequencing Batch Reactor Technology**. Scientific and Technical Report No. 10, IWA Publishing, London, 2001.
2. MACE, S., J. MATA-ALVAREZ, **Utilization of SBR Technology for Wastewater Treatment: An Overview**. Industrial & Engineering Chemistry Research, vol. 41(23), 2002, pp. 5539-5553.
3. BRDYS, M. A., M. GROCHOWSKI, T. GMINSKI, K. KONARCZAK, M. DREWA, **Hierarchical Predictive Control of Integrated Wastewater Systems**. Control Engineering Practice, vol. 16(6), 2008, pp. 751-767.

4. HOLEND, B., E. DOMOKOS, A. RÉDEY, J. FAZAKAS, **Dissolved Oxygen Control of the Activated Sludge Wastewater Treatment Process using Model Predictive Control**. Computers and Chemical Engineering, vol. 32(6), 2008, pp. 1270-1278.
5. PIOTROWSKI, R., M. A. BRDYS, K. KONARCZAK, K. DUZINKIEWICZ, W. CHOTKOWSKI, **Hierarchical Dissolved Oxygen Control for Activated Sludge Processes**. Control Engineering Practice, vol. 16(1), 2008, pp. 114-131.
6. PIOTROWSKI, R., **Two-Level Multivariable Control System of Dissolved Oxygen Tracking and Aeration System for Activated Sludge Processes**. Water Environment Research (in press), 2014.
7. DUZINKIEWICZ, K., M. A. BRDYS, W. KUREK, R. PIOTROWSKI, **Genetic Hybrid Predictive Controller for Optimised Dissolved Oxygen Tracking at Lower Control Level**. IEEE Transactions on Control Systems Technology, vol. 17(5), 2009, pp. 1183-1192.
8. WAHAB, N. A., R. KATEBI, J. BALDERUD, **Multivariable PID Control Design for Activated Sludge Process with Nitrification and Denitrification**. Biochemical Engineering Journal, vol. 45, 2009, pp. 239-248.
9. IRATNI, A., R. KATEBI, M. MOSTEFAI, **Non-linear State Dependent Differential Riccati States Filter for Wastewater Treatment Process**. Studies in Informatics and Control, vol. 20(3), 2011, pp. 247-254.
10. FAN, L., K. BOSHPANOV, **Fuzzy Logic based Dissolved Oxygen Control for SBR Wastewater Treatment Process**. Proceedings of the 8th World Congress on Intelligent Control and Automation, Jinan, July 06-09, 2010, China.
11. BELCHIOR, C. A. C., R. A. M. ARAÚJO, J. A. C. LANDECK, **Dissolved Oxygen Control of the Activated Sludge Wastewater Treatment Process using Stable Adaptive Fuzzy Control**. Computers and Chemical Engineering, vol. 37(10), 2012, pp. 152-162.
12. VREČKO, D., HVALA, N., STRAŽAR, M. **The Application of Model Predictive**

- Control of Ammonia Nitrogen in an Activated Sludge Process.** Water Science and Technology vol. 64(5), 2011, pp. 1115-1121.
13. ÅMAND, L., B. CARLSSON, **The Optimal Dissolved Oxygen Profile in a Nitrifying Activated Sludge Process - Comparisons with Ammonium Feedback Control.** Water Science and Technology vol. 68(3), 2013, pp. 641-649.
 14. HENZE, M., W. GUJER, T. MINO, T. MATSUO, M. C. WENTZEL, G. v. R. MARAIS, M. C. M. van LOOSDRECHT, **Activated Sludge Model No. 2d, ASM2d.** Water Science and Technology vol. 39(1), 1999, pp. 165-182.
 15. KRAWCZYK, W., R. PIOTROWSKI, M. A. BRDYS, W. CHOTKOWSKI, (). **Modelling and Identification of Aeration Systems for Model Predictive Control of Dissolved Oxygen – Swarzewo Wastewater Treatment Plant Case Study.** Proceedings of the 10th IFAC Symposium on Computer Applications in Biotechnology, Cancun, June 04-06, 2007, Mexico.
 16. MORARI, M., E. ZAFIRION, **Robust Process Control.** Prentice Hall, New York, 1989.
 17. **SIMBA User's Guide.** 2014, Available: <http://www.ifak-system.com/en/environmental-simulation/simba/>.
 18. ÅSTRÖM, K.J., B. WITTENMARK, **Adaptive Control**, 2 edition. Prentice Hall, New York, 1994.