



## **A NEW DESIGN OF THE PODED AZIMUTH THRUSTER FOR A DIESEL-HYDRAULIC PROPULSION SYSTEM OF A SMALL VESSEL**

**Czesław Dymarski**

*Gdansk University of Technology*  
*Ul. Narutowicza 11/12, 80-950 Gdańsk, Poland*  
*tel.: +48 58 347 16 08, fax: +48 58 348 63 72*  
*e-mail: cpdymars@pg.gda.pl*

**Marcin Zagórski**

*Eaton Automotive Components Sp. z o.o.*  
*Ul. 30 Stycznia, 5583-110 Tczew*  
*tel.: +48 58 53 29 318*  
*e-mail: [marcinzagorski@eaton.com](mailto:marcinzagorski@eaton.com)*

### **Abstract**

*The paper presents a comparative analysis of different kinds of ship propulsion systems with azimuth thrusters and also constructional solution of an azimuth thrusters destined for small vessel with diesel-hydraulic driving system. Characteristic feature of the thrusters is localization under the water of the main hydraulic motor which drives a fixed pitch propeller located inside a nozzle. The motor is attached to the pod which is fixed to rotatable 360 ° vertical column with nozzle. The shaft of the motor is directly coupled inside pod with propeller shaft. The column is driven by a small hydraulic motor through planetary and cylindrical gears. The thruster has been build and preliminary tested at HYDROMECH Company and now is prepared for laboratory research.*

**Keywords:** *ship propulsion systems, diesel-hydraulic driving system, hydraulic azimuth thrusters*

### **1. Introduction**

Marine propulsion systems, as well as other devices and technical systems are subjected to continuous process improvement, both in their range of design solutions, as well as the type of drive and control. At the Faculty of Ocean Engineering and Ship Technology of the Gdansk University of Technology many years researches and design works of ship systems are conducted, especially low-power. As part of this work has produced several original design solutions propulsions, including:

- Controllable pitch propellers, one of which was used on a submarine and two others on small fishing cutters [1 and 9].
- Azimuth thrusters with bevel gear in the pod and alternative-powered by an electric or a hydraulic motor placed in the hull of a ship for dual main drive of the two-segments inland passenger ship [3– 7].
- Poded azimuth thrusters with electric motors with rare earth magnets placed in the pod and directly connected with the propeller, and powered with photovoltaic panels. Propulsions of this type were used on the small boats participating in international regattas [8].

- Poded azimuth thrusters with hydraulic main motor placed under water and connected directly with a propeller.

The above-mentioned experience allowed undertaking the development of modern efficient propulsion system for small vessels with high demands on manoeuvrability and reliability. Following is presented an analysis of current marine propulsion systems with azimuth thrusters and new constructional solution with working description of the hydraulic poded azimuth thruster. This thruster was designed and built within conducted at the Faculty the development project NCBR: “Development project of propulsion-technological system for a fishing vessel adopted to operate in Polish economic zone”.

## 2. Analysis of contemporary marine propulsion systems with azimuth thrusters

The main ship propulsion systems with azimuth thrusters are now becoming popular especially with two thrusters, each with the possibility of execution complete rotation of the propeller nacelle in the horizontal plane. This is due to a number of essential advantages of such a propulsion system, the most important being:

- Very good properties of the vessel manoeuvring.
- Reduced demand for space power plant room inside the ship
- Elimination the need for traditional, relatively expensive and involved a lot of space, steering systems
- Possibility of using instead of a one large a few smaller higher speed engines driving, directly or through a reduction gear, generators (diesel-electric drive) or hydraulic pumps (diesel-hydraulic drive). The larger number of independent sources of energy with the possibility of their arrangement in the separate rooms increases reliability of the propulsion system, and thus the safety of navigation also. Besides, do not require high engine room space, allowing more efficient use of valuable space on the ship, locating power plant in relatively the least attractive part of the hull bottom.
- The modular nature of the design of thrusters considerable simplifies and accelerates the construction of the vessel, equipment installation and replacement, if necessary.

It should be noted, however, that this driver with the azimuth thrusters possess a significant disadvantage relative to conventional propulsion system, especially with low-speed two-stroke engine directly connected with the propeller shaft. It is the lower efficiency resulting from of energy losses those found in the reduction gear, which must be applied here. The value of these losses depends on the type of gear.

The highest system efficiency can be achieved using a mechanical gear transmission type "Z" with a double bevel gear. However such system is not preferred because of the complexity of the design and the inability to gear ratio smooth adjustment. The second factor, in the case of a propeller with fixed pitch unable permanent job in the optimum engine speed under varying sea conditions, which can significantly reduce the efficiency of the system in the long term operation. Use of the controllable pitch propeller would solve this problem, but would significantly increase the cost and complexity of the system. These factors make this system rather less favourable in comparison to the rest of the mentioned systems.

The use of electric or hydrostatic transmission is likely to require twice the change a form of energy: in the first mechanical energy into electrical or hydraulic and next into mechanical again, which is accompanied by specific loss.

Modern electric transmissions using frequency converters are characterized by relatively high efficiency, yet allow smooth adjustment of the propeller speed while maintaining constant optimal engine speed, which is an important advantage.

High-pressure hydrostatic transmissions have even better features, as far as possible control and overload protection is considered, from electrical, but their efficiency is slightly lower. The work presented in [4] is a comparative analysis of two propulsion systems: diesel electric and diesel hydraulic capacity of  $2 \times 150$  kW shows that the efficiency of the propulsion system with hydrostatic transmission was about 5% smaller. It should be noted that in the analyzed propulsion systems, there were used azimuth thrusters with bevel gear placed in the pod and driving electric or hydraulic motor located in an upright position in the hull directly above the nozzle with propeller, what can be seen in Fig 1 and Fig 2.

Selected asynchronous electric motors were, unfortunately, about 15 times heavier and larger than the high-pressure hydraulic motors, and the total weight of the diesel-electric system increased by about 58%. Also, the cost of the electric motor was about 21% greater than the hydraulic and the whole system - by about 26%.

The above discussion does not include constructional solutions with motors placed under water in a pod, although such propulsion systems, called podded systems, are now increasingly being used especially on large passenger ships such as Queen Mary 2, and on some special ships and naval vessels. However, these are usually diesel-electric propulsion systems with high

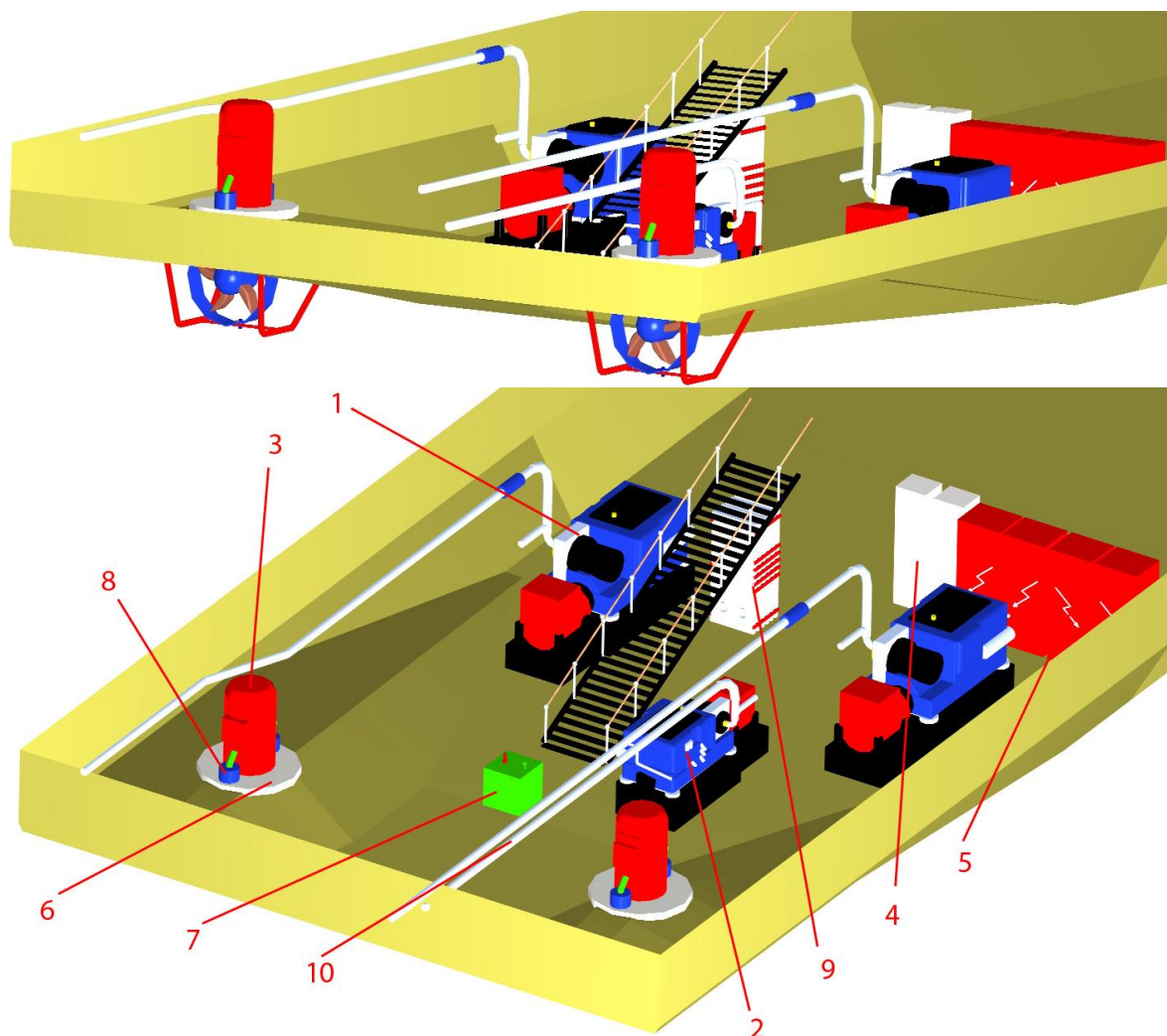

Fig. 1. View of an example arrangement of the main components of the diesel-electric propulsion system fitted with the electric motors in vertical position [4]. Notation : 1 – electric generating set, 2 – auxiliary electric generating set, 3 – electric three-phase asynchro-nous cage motor driving the propeller, 4 – frequency converter, 5 – main switchboard, 6 – rotatable thruster, 7 – hydraulic unit for supplying hydraulic motors, 8 – hydraulic motor fitted with planetary gear to drive the mechanism rotating the column of rotatable thruster, 9 – central „outboard water – fresh water” cooler, 10 – exhaust piping with silencers

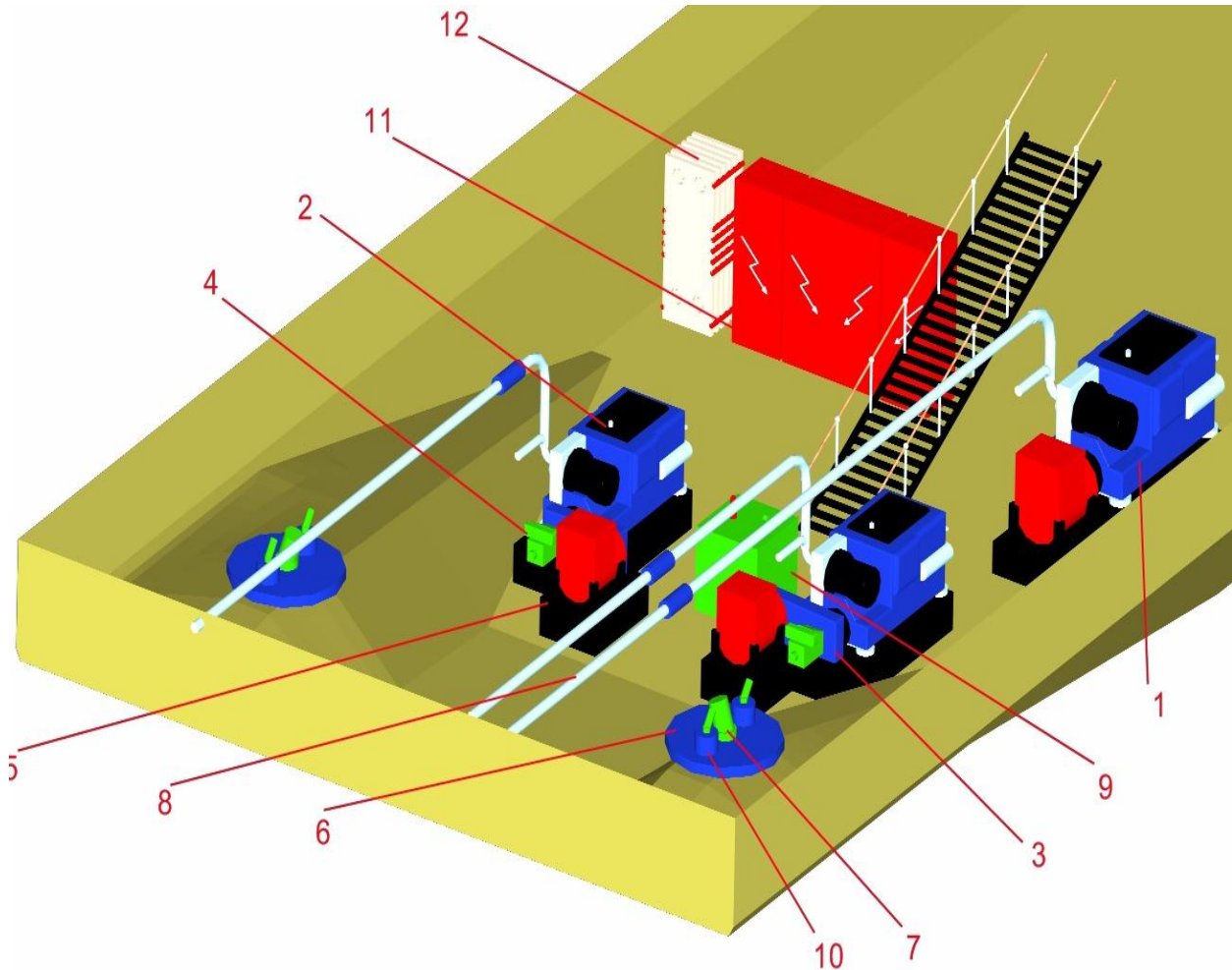

Fig. 2. View of an example arrangement of the main components of the diesel-hydraulic propulsion system [4].

Notation : 1- electric generating set, 2 – combustion engine, 3 – mechanical gear, 4 – the main pump unit to drive the propeller, 5 – electric generator, 6 – rotatable thruster, 7 – hydraulic motor driving the propeller, 8 – exhaust piping with silencers, 9 – hydraulic oil supplying unit, 10 – hydraulic motors to rotate the rotatable thruster around vertical axis, 11 – electric switchboard, 12 – central „outboard water – fresh water” cooler.

power electric motors with a relatively small size, fitted with permanent magnets made of rare earth. In the U.S., there are also constructed the hydraulic podded thrusters, but less power up to several hundred kW. The hydraulic motors are specially designed with elongated shape and with small lateral dimensions.

Podded propulsion systems in addition to the aforementioned have additional advantages such as:

- Further reducing the need for power plant space inside the ship.
- Smaller hull vibrations induced by the motor - propeller driving system job, and thus less noise and greater comfort of navigation, which is extremely important especially for passenger ships.

However these systems have some drawbacks, namely:

- The high cost of motor to drive the propeller with a correspondingly high power at relatively low speeds and small lateral dimensions so that they can be installed inside the pod of the thrusters. This is especially true for electric drive, as it requires the use of high torque motors with permanent magnets made of rare earth materials, which range in the market, is very limited and usually requires execution of the order, which dramatically increases the cost. In the case of hydraulic drive, the motors must be a high-pressure axial piston rather with a

relatively small lateral dimensions, which are virtually not available in the market. They are produced only by very few manufacturers of complete equipment of this type, that is, azimuth and tunnel thrusters.

- Serious problem in the case of diesel-electric propulsion with sufficient discharge of heat generated by electric motors from a small, hard-to-access space inside the pod.
- The problem of ensuring the proper tightness of the pressure chambers and inside of the pod.

In summary the following characteristics it should be noted that in the case of vessels which are required to have high manoeuvrability, ability to work in widely differing load conditions and a high comfortable sailing advantages podded ship propulsion system are the predominant.

### 3. Design assumptions

As a result of previous research work on the analysis of different propulsion systems presented in [1-9] it was decided to equip, mentioned in the introduction of a small fishing vessel, of a length of about 12 m, with the diesel-hydraulic drive system consists of two azimuth thrusters with power on each propeller shaft 80 kW.

Due to the fact that the hydraulic drive enables a relatively easy adjustment of the direction and speed values assumed that the thrusters should be equipped with fixed pitch propeller, which are relatively simple in design, and therefore more reliable and less expensive than controllable pitch propeller. Furthermore, it was assumed that the propellers should be placed in the nozzles, which allows a reduction of their external diameter, and also protects the propeller blade from rope becoming caught and hitting a floating beam or ice floe.

The basic propeller regime operating at full load power should take place at a constant direction of rotation of the propeller with the possibility of changing the speed depending on the needs and marine conditions. Manoeuvring ship can achieve by changing the angular position of the column with propeller, regardless of each of the thrusters. Reversing the propeller should be possible, but in a limited range of load and used only in justified cases, for example, needs a very precise manoeuvres. This restriction is justified by different conditions of the water flow in both directions, especially through the nozzle and the resulting wide variation in the efficiency of the drive system.

Due to the lack of free space on small fishing vessel, drive system, including azimuth thrusters should be characterized by a compact modular design with relatively small dimensions and weight.

To facilitate the selection of the best possible design solution developed technical documentation of two variants of the thruster, realistic to carry in a relatively short time and an acceptable price. The first variant is based on a more popular solution consists in using the propeller drive motor located in the hull above of the vertical column and nozzle. The drive from the motor shaft is transmitted through the vertical shaft and placed inside the pod bevel gear, to the propeller shaft. In the second variant, the motor was placed under water, attached to the pod, inside which are a propeller shaft and bearings.

The both design documentations were sent to several potential producers to prepare their offers for the two varieties of thrusters. As a result of technical analysis of both design solutions and offerings given in terms of costs and their execution was decided to perform the second of the above-mentioned variants of thrusters, it means with hydraulic motor placed under water.

The main advantage of this solution is a direct connection of the motor shaft to the propeller shaft without the need for gear, which simplifies design and improves the efficiency of the propulsion system and reduces the investment costs. Although the engine must be operated at lower speeds, and for this reason must be a little larger and more expensive, but the cost of additional bevel gear and the vertical shaft assembly would be significantly higher.



#### 4. Description of structures

The design of the thruster in longitudinal section of the assembly is shown in Fig. 3 and in three-dimensional Fig. 4. A fixed pitch propeller is set on tapered journal with parallel key of the shaft 2 and secured by bearing nut 3 screwed onto the end of the shaft. In order to protect the surface of the shaft and mentioned threaded connections against water intrusion, the cap 4 was fastened with screws and sealing O-ring to the front surface of the propeller hub. The propeller shaft is set on two identical tapered roller bearings 5 in the pod 6. The tapered roller bearings pair was applied by the need to transfer lateral forces in addition to the considerable axial forces in both directions caused by the work of the screws with the ability to change the direction of its rotation. In the front journal of the shaft an axial bore with splineway with key is made, in which the shaft of the hydraulic motor of the type 7 A2FM 125 REXROTH Company is mounted. The flange of the motors body is attached to the front face of the pod with four screws. It should be noted that the external lateral outline of the pod is the square of the same geometry as the outline of the motor flange. In order to minimize the flow resistance of water flow through the nozzle, the motor is mounted in the position shown in the figures and with hydraulic pipes screened by fairwater cap, better visible in Fig. 5 and Fig. 6. The space inside the pod is closed from the back by the cover 8. In hub of the cover there are three sealing lip rings set, cooperating with the sleeve 9, which is embedded on a cylindrical journal in the middle part of the shaft. Sleeve 9 is made of stainless steel and sealed against the propeller hub by means of O-ring.

The pod 6 is flanged connected to the bottom of the rotary column 10 and the rod 11. The lower part of the column is shaped thick-walled pipe flanges ended. An additional third small flange incomplete, truncated in front and back side is a little below the top flange, and is used to attach the nozzle 12, which is shown in Fig. 5. In the figure it is visible also a second attachment point of the nozzle by means of the flat bar welded in horizontal position to the nozzle and screwed by bolts to the bottom surface of the pod. To cylindrical surface of the column 10, in the middle of its length is a rectangular connection plate 13 welded. In the plate there are three openings connecting three concentric oil channels inside the column. Three steel pipes, applying oil to the hydraulic motor 7, are welded to the flange 14, which is attached by bolts to connection plate 10. In the flange 14 there are a few small-diameter holes to allow the connection of space inside the pod and the motor with the low-pressure drain channel in the column, bypassing the two main motor supply channels. In the cylindrical sockets of the upper part of the rod 11 there are two coaxially pipes 15 and 16 of different diameters, sealed by the rings type "O", which created three separate oil channels. Two internal channels are used to power the main engine, and the channel between the column and a larger diameter pipe is used for removal of oil from leaks in the motor.

The lower part of the column 10 is connected by connector flange with the upper part of column 17, which is set in the body of the foundation 18 by means of two bearings: single-row cylindrical and double-row spherical roller. Due to the small axial loads originating only from the weight of the suspended on the column elements, a selected double-row spherical roller bearing is entirely sufficient to transfer both of these axial and transverse loads. The space inside the body 18 is protected against ingress of water with the means of three lip rings 19 cooperating with the sleeve 20 made of stainless steel, built in a similar way as in the pod. An axial hole in the top of the column is the same diameter as the lower part, so that the sizes of

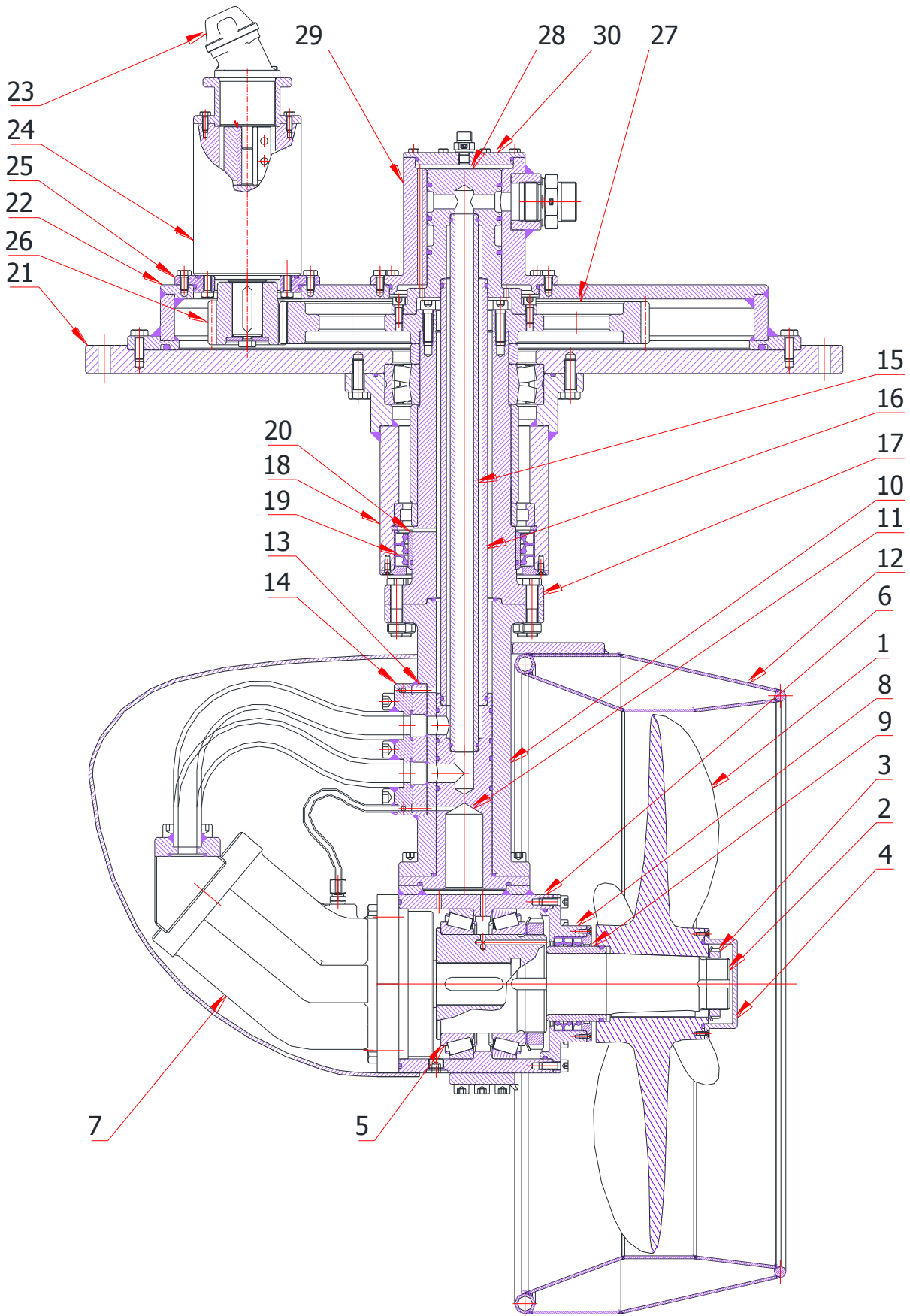
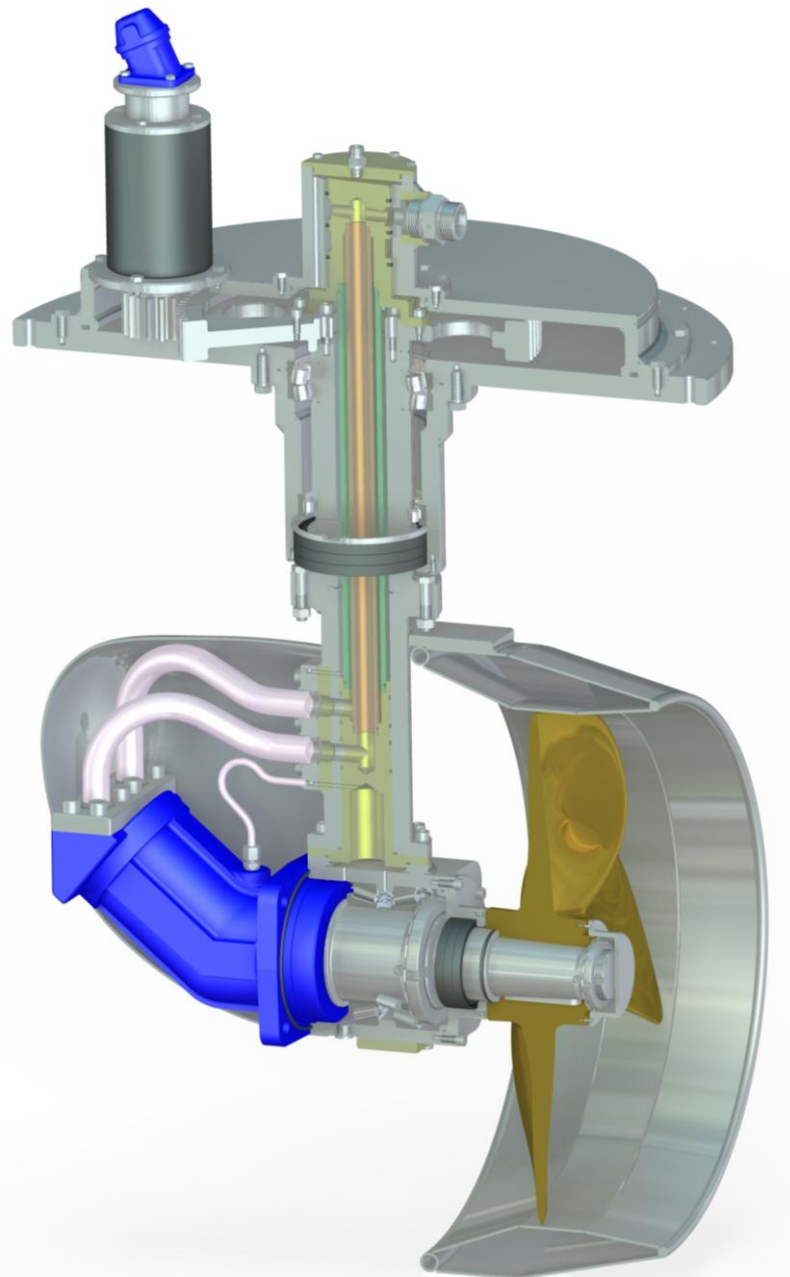

Fig3. Longitudinal section of the hydraulic podded azimuth thruster





*Fig. 4. Three-dimensional longitudinal section of the hydraulic poded azimuth thruster*

three channels are identical in the both parts. In order to ensure lubrication there the radial hole is made in the wall of the column at a height above the sleeve 20 and cylindrical roller bearings, allowing the flow of returning oil through the space with the located above bearings and the gear 26.

The body of the foundation 18 located in the vertical hole the hull flange is fastened to the lower surface of the foundation plate 21. This plate of disk shape is attached with screws to a suitably prepared foundation within the vessel. To the upper surface of the plate 21 the body 22 of the thrusters slewing mechanism gear is attached. Due to the relatively low loads and low speeds used here a single-stage cylindrical gear with straight teeth with gear ratio 1:5,1. The drive of this gear is realized by means of a hydraulic motor 23 A2FM5 REXROTH company and a planetary gear type 24 REP125 TRAMEC company, with gear ratio 35, which is attached by a flange 25 to the body 22. The small cylindrical gear wheel 26 is mounted directly on the journal of the planetary gear shaft with a parallel key. The large gear wheel 27 is mounted with screws on the upper face of the upper part of the column 17. The large wheel 27 is rigidly connected to pin 28 of



the upper mounting oil tubes unit. This pin with suitably shaped cylindrical outer surface, the channels and rings set with the possibility of turning in the housing 29 provides to be the rotary pressure joints. The housing is closed at the top by the cover 30 and is fixed rigidly to the gear body 22. Two connectors for connection of high pressure oil pipe are welded to cylindrical outer surface of the housing 29. Third, a small oil connector is placed in the cover 30.

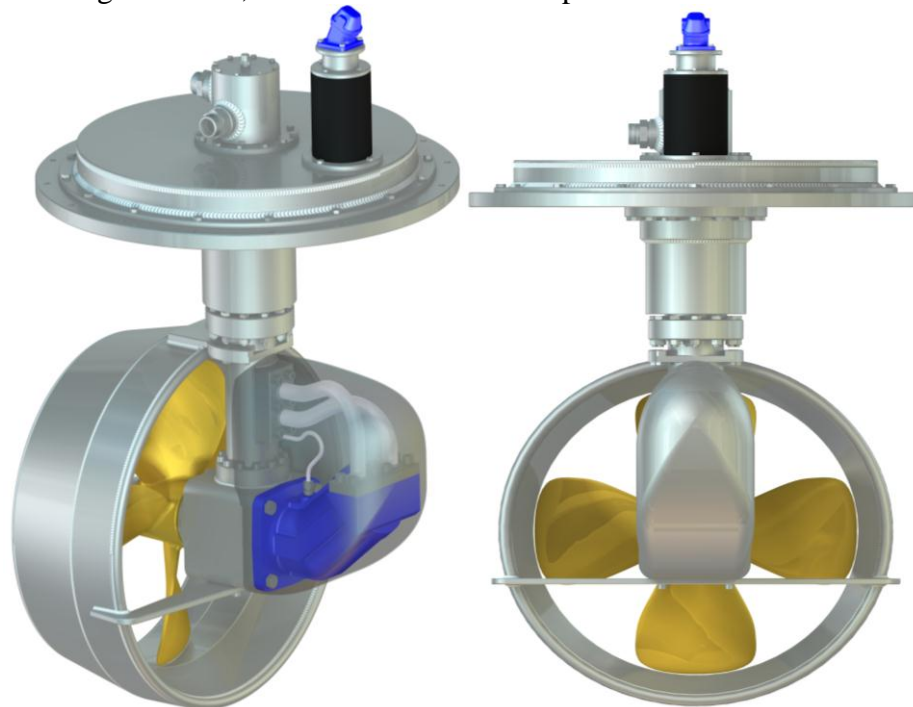

*Fig. 5. Axonometric (with transparent fairwater cap) and central projection view of the azimuth thruster.*

## 5. Concluding Remarks

Presented in the article design solution of the small power podded azimuth thrusters is an attempt to introduce this type of drive for small vessels. The aforementioned advantages of podded propulsion systems justify the need for research work in this subject. The principal feature and advantage of presented solutions is usage of typical hydraulic motor of wide recognized company, which although located under the water, but is easily accessible. It facilitates the control and possible replacement of the motor. It should be noted that up to now there are none of commercially available low-power hydraulic motors, which would be aligned transverse dimensions for installation in the pod. The motor which was used here is not beneficial in this regard, but according to the authors, screened by fairwater cap, as shown in Fig. 5 does not significantly interfere with the flow of the water stream to the propeller located in the nozzle. By the time the article submission the thruster was made and subjected to acceptance tests at the manufacturer. Due to the limited technical capabilities and measuring these tests were limited to checking tightness of all the oil channels and the correctness of the mechanisms at work, but without a load.

Laboratory test of the thrusters together with complete diesel-hydraulic propulsion system at full load range will be conducted at the beginning of 2012.

The thruster, whose photograph is shown in Fig. 6, was presented on 16th International Maritime Exhibition BALTEXPO - 2011 in Gdansk, where it gathered much attention, especially owners of small vessels.



Fig. 6. Photography of the azimuth podded thruster presented on the 16th International Maritime Exhibition BALTEXPO – 2011 in Gdansk

## References

1. Dymarski Cz.: The hydraulic drive and control of the equipment of the small fishing cutter. Marine Technology Transaction, Technika Morska, Polish Academy of Sciences - Branch in Gdańsk, Marine Technology Committee. Vol. 13, 2002 r.
2. Dymarski Cz., Dąbrowski K.: Automatic control systems for ships fitted with podded propulsion drive (POD). Polish Maritime Research. Special issue 2004. S.
3. Dymarski Cz.: An azimuthing Diesel-hydraulic propulsion system for inland vessel. IV International Scientifically – Technical Conference EXPLO – DIESEL & GAS TURBINE '05. Gdańsk – Miedzyzdroje – Kopenhaga, May 09 - 13, 2005 r.
4. Dymarski Cz., Rolbiecki R.: Comparative analysis of selected design variants of propulsion system for an inland waterways ship. Polish Maritime Research, No 1(47) 2006 r.
5. Dymarski Cz., Skorek G.: A design concept of main propulsion system with hydrostatic transmission gear for inland waterways ship. Polish Maritime Research, - 2006. nr S2.
6. Dymarski Cz.: Propulsion system with a hydraulic transmission for a low draught inland vessel. Marine Technology Transactions. Technika Morska. - Vol. 17, 2006.
7. Dymarski Cz.: Analysis of two design kind of propulsion for an inland vessel. Journal of POLISH CIMAC. Energetic Aspects. Vol.2, No 1. Gdansk 2007. Editorial Office: Gdansk University of Technology, Faculty of Ocean Engineering and Ship Technology.
8. Dymarski Cz., Leśniewski W.: Numerical investigations of the engine cooling system in small power vessel pod propulsion system. Polish Maritime Research. - Vol. 15, No 4(58), 2008 r.
9. Dymarski Cz.: Effective and environmental friendly propulsion system for small fishing cutter. 1st International Symposium on Fishing Vessel Energy Efficiency E-Fishing / Adrian Sarasquete - Vigo, Hiszpania, 2010.