

An integrated hydraulic drive system of a novel device for launching lifeboats from large passenger ships

Czesław Dymarski, Prof.
Gdańsk University of Technology

ABSTRACT



This paper presents a continuation of the projects [5, 6] dealing with the novel concepts of evacuating people from large passenger ships. A novel integrated drive and control system for chain lift with lifeboats fastened on it as well as for stern port-ramp, is presented. Additional novel elements is the application of the stern port-ramp fitted with a buoyancy element, and its increased capability of automatic adjusting its operational deflection in the case of a large forward trim of ship. It increases safety and comfort of evacuation in the difficult conditions, but to obtain it a more complex drive and control system has been required to be designed.

Keywords: ship deck equipment; ship evacuating systems; life saving appliances systems; lifeboat chain lift; hydraulic drive and control system

INTRODUCTION

Contemporary large passenger ships are able to take onboard even six and half thousand of people [8]. One of the most complex problems the designers and ship owners of such ships face is to ensure safety in the case of a fire or danger of ship sinking resulting in necessity of fast abandoning the ship by such a large number of people especially in heavy weather conditions. For this aim have been used so far life boats and rafts located in series along both ship sides, placed on special davits on evacuation deck as shown in Fig. 1 presenting the *Queen Mary 2*, one of the largest and most modern passenger ships.

According to the requirements in force the davits are to ensure putting the life boats overboard with the use of gravity forces or stored energy in the conditions of ship's heel up to 20° and trim up to 10° and then embarking people on them and lowering the boats to water.

To the group of davits which lean out overboard together with life boats by using gravity forces the following belong:

- the quadrant davits shown in Fig. 2, which have been used most often so far on large passenger ships,
- the gravity roller track – quadrant davit shown in Fig. 3, used less often in present because of a greater space needed to accommodate them,
- the quadrant davits shown in Fig. 4, applicable rather to smaller ships.



Fig. 1. The passenger ship *Queen Mary 2* with visible life boats placed on ship sides [7]

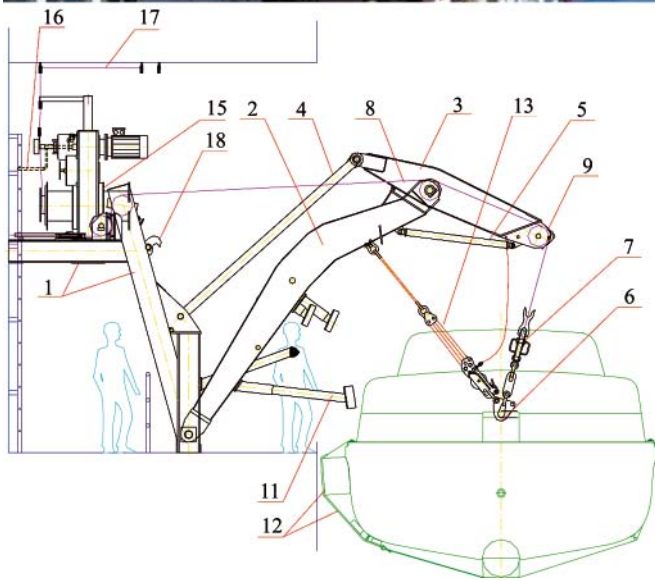

Fig. 2. The life boat quadrant davits. Up – a photo of the davits in voyage position; down - in the position along ship side for embarking the people on the lifeboats from evacuation deck

To the group of the davits which require some energy for putting them overboard the following belong:

- the telescopic davits shown in Fig. 5, which accommodate relatively smallest space and hence are often and often applied on the newest passenger ships,
- the quadrant davits fitted with a leaning mechanism driven by hydraulic cylinder,
- the pivot davits used mainly on small rescue boats.

During evacuation of people from an endangered ship equipped with the above mentioned devices the following operations are required to be performed:

- to remove the protection of fastening devices of boats and davits, used during voyage,
- to put overboard the davits together with the boat hanging on them and lowering the boat to the level of evacuation deck,
- to draw-up and fix the boat on the level of evacuation deck,
- to embark the people on the boat, take the seats and fasten the belts by them,
- to free the boat out of the ship side, steady lower the boat onto water and release hooks and lines after launching,
- to start the engine and sail the boat away from the ship.

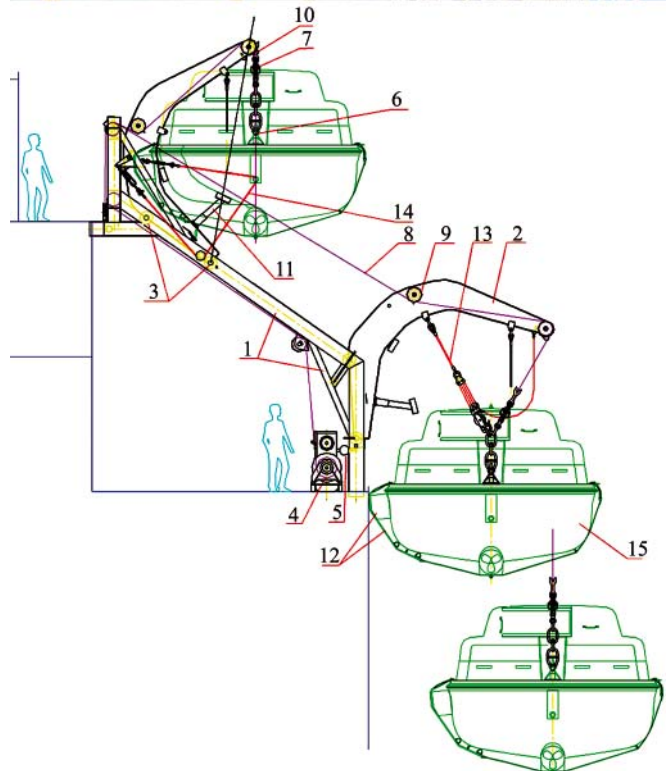

Fig. 3. The gravity roller track – quadrant davits in various positions during trial evacuation of people from ship.

Because of a limited space some of the above mentioned operations especially those connected with boat movement cannot be performed simultaneously by neighbouring devices that highly increases duration of evacuation time. It should be mentioned that the most difficult are the last three operations especially in the rough sea conditions.

In this paper is presented a novel concept of evacuating the people from a large passenger ship, elaborated in the Faculty of Ocean Engineering and Ship Technology, Gdansk University of Technology, within the frame of the European project SAFECRAFTS. The concept covers a design solution of the novel device already presented in the publications [5, 6], as well as an original drive and control system for two basic devices of the system, namely the stern ramp and the chain lift on which life boats are fastened.



Fig. 4. The life boat davits during and after installation of them on a sailing passenger ship.

AIMS AND MAIN ASSUMPTIONS OF THE ELABORATED CONCEPT OF THE DEVICE

The main aim and assumption of the project was to elaborate a novel method and device capable of evacuating people from an endangered passenger ship in heavy sea conditions, in a safe and more comfortable way than that has been used so far, and simultaneously within a shorter time.

The conceptual design was elaborated to be applicable to ships similar to the *Queen Mary 2*, the most representative for the group of ships of the kind, and because of availability of its technical data.

The main technical and operational parameters of the ship are the following:

Length	– 345 m
Breadth	– 41 m
Draught	– 10 m



Fig. 5. Photos of the life boat davit fitted with a telescopic mechanism for putting the boats overboard. Left - in voyage position; right - in overboard position.

Depth (from keel to funnel)	– 72 m
Mass displacement	– 150 000 t
Maximum speed	– ~30 knots
Installed power	– 115.4 MW
Drive	– 4 pod propellers of 21.5 MW power each, including two azimuthal ones
Number of passengers and crew members	– 2620 + 1253 = 3873 persons.

DESIGN CONCEPT AND PRINCIPLE OF OPERATION OF THE DEVICE

The designed evacuation system presented in Fig. 6 consists of two independent devices located aft, outside valuable, useful space of the ship. Each of the devices covers a port - ramp and four mechanically mutually coupled chain lifts placed in a special casing, two of them on each side walls.

In the lower part of the casing a slipway equipped with rollers is placed. The casing is open from the aft side. Only the lower, rear part of the casing can be closed with the use of a simple port - ramp fitted, on its inner side, with a frame with rollers, which can form, after opening the ramp, an extension of the slipway reaching below water level.

On the lift chains are fastened suitably spaced catches on which closed life boats are placed. During voyage the port - ramp and chain lifts are blocked mechanically. Also, the boats are blocked in their positions on the lift catches by using the so called slip hooks which, apart from a typical releasing mechanism, are fitted also with a hydrostatic

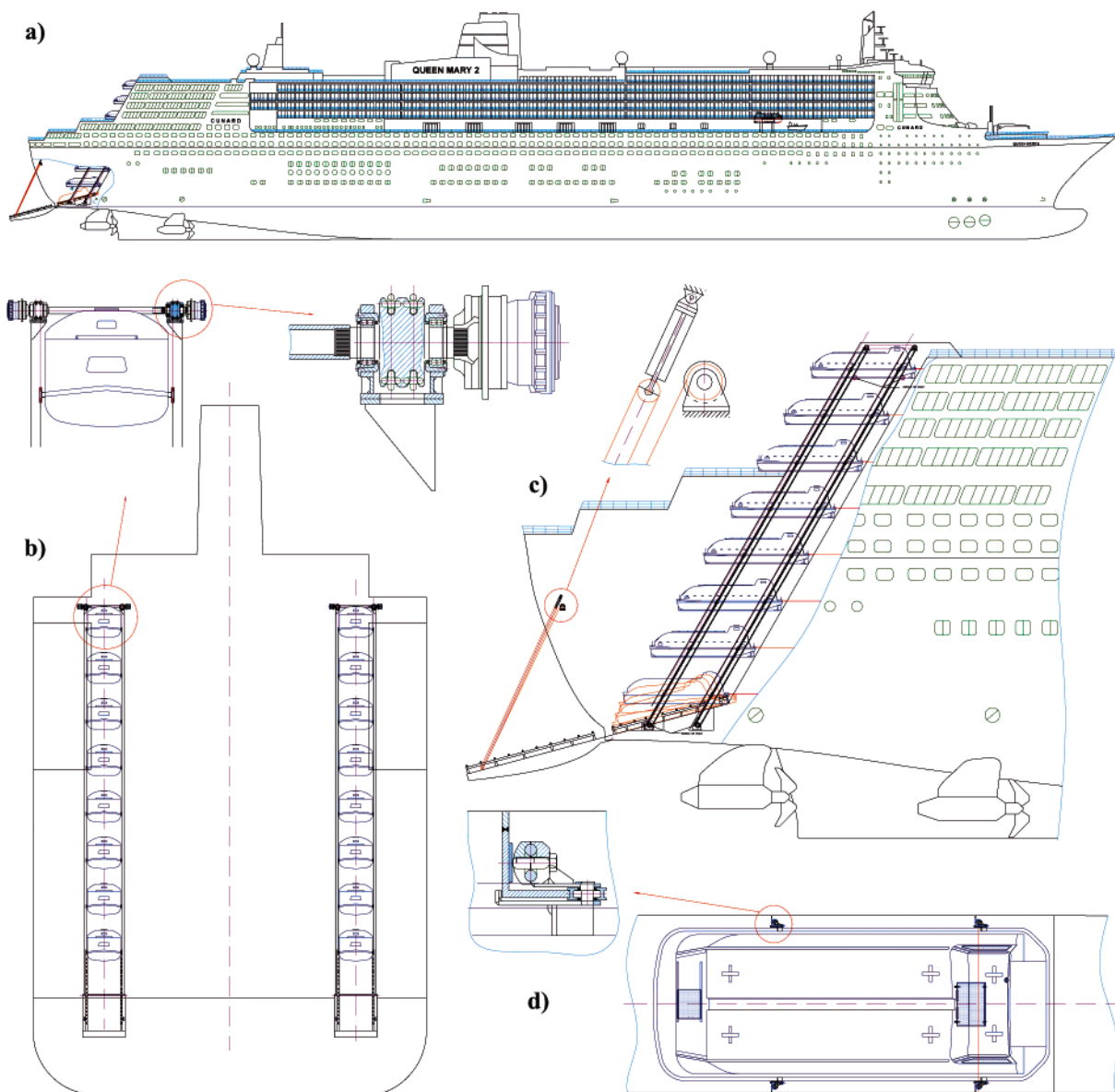

Fig. 6. General concept of the device for evacuating the people: **a)** Side view of the ship with the installed device; **b)** rear view of the ship with visible elements of the drive system; **c)** cross-section of the casing with chain lifts and boats and visible mechanism for opening the port-ramp; **d)** top view of the boat placed on the lift in the casing, with visible elements of seating of the boat on the lift.

release. Owing to that in the case of sinkage of the ship the boats are automatically released.

Because of the shape and location of the casing, eight life boats are used in each casing for a ship like the QM2. The number of boats is limited by the ship's depth and spacing to be kept between successive boats. The boats are large enough to accommodate 120 or 150 persons. The spacing between boats must be such as to avoid collisions during evacuation.

Specificity of the presented concept consists in that it makes it possible to simultaneously evacuate all the people onboard and start remotely the operation also from inside the boats.

The evacuation process initiated this way is automatically continued until the last boat is launched.

When the first boat is settled on the slipway in order to drive down on rollers in uniformly accelerated motion the next boat located on the chain lift approaches it. For this reason it is very important to keep suitable spacing between the boats placed on the lift.

A favourable feature of the solution in question is that persons embark the boat when it is stiffly connected with ship's hull. This way, in the presented solution, the problem of

movement of the boat against the ship, which usually occurs in the case of embarking the boat hanging already along ship side, was eliminated. Owing to this, people are not exposed to stress and fear which is a typical reaction to the sight of rough sea in the gap between the boat and ship side during embarkation on the boats launched in the traditional way by means of side boat davits. There are no impacts of the boat against ship side, to which the boat and passengers inside are usually exposed during lowering the life boats hanging on lines along side of the ship rolling in waves, especially in heavy weather conditions. In the discussed solution the process of lowering and launching the boats is fully controlled and free from any sudden acceleration and panting against water surface as it is the case during evacuation with the use of systems based on free-fall lifeboats. Life boat engine is started up already during the boat's going down along the slipway. As the boat moves during launching in opposite direction relative to the ship, hence, floating already in water, it continues the motion and sails away from the endangered ship. The above mentioned features are of special importance for older and handicapped persons for which both stress and sudden accelerations could be dangerous.



Structure of the boats used in the presented solution contains some features of both the free-fall boats and life boats lowered with the use of side davits. Like free-fall boats, they have appropriately formed sides adjusted to going down on rollers. Because of their launching mode which produces much smaller dynamic loads they do not need to be as much resistant to loads as the free-fall boats. Their proportions are similar to those of free-fall boats, namely, they are more slender and longer than the side life boats. This makes it possible to save a part of expensive, usable space of ship. The launching mode consists in lowering the boats at a controlled speed by using the chain mechanism. The motion takes place under action of gravity forces and its speed is limited by means of a two-way flow controller installed in the hydraulic lift system, or a centrifugal brake. The boats are horizontally placed on the lift both during ship voyage and lowering process. Reaching the lower part of the casing the boat, while settling on the rollers fastened to the frame inclined by 15° against the deck level, releases itself from the chain lift. In the initial, fore part of the slipway three rollers are installed very close to each other to provide a greater comfort during the transient phase of evacuation when the boat changes its angular position. The boat travels its final path along the slipway inside the ship hull and next along the stern ramp, developing uniformly accelerated motion and freely going down on the rollers, and it finally enters the water at a relatively small slope angle. This highly moderates dynamics of its contact with water and lowers accelerations acting on the boat and people inside.

In the proposed solution a simple port - ramp was used. It consists of a main segment built of steel plating and a buoyancy element in its rear part, as well as a number of stiffeners and frames which provide sufficient stiffness and strength of the ramp in heavy sea conditions. On the inner side of the ramp there is a metal frame made of square cross-section pipes to which rollers are fixed so that after opening the ramp the structure serves as an extension of the slipways, along which the boats can go down to water. Weight of the port-ramp is greater than its full buoyancy that means that its position as the extension of the slipway, will be maintained also in the case of ship's trim astern and its full immersion. The solution is favourable as on the one hand the limited buoyancy of the ramp decreases loading exerted to the drive system and on the other hand it does not cause dynamic displacements of the ramp against ship's hull in the case of evacuation at rough sea.

The drive system of the ramp is untypical as it makes it possible to automatic increasing its deflection angle in the case of a large ship trim forward when the end of the opened ramp is above water level.

Deflection process of the port- ramp is realized by means of two identical line hoisting winches, or one double-drum winch, and double pulley block system on both sides of the ramp. The upper pulley block of each line pulley block system of the ramp lowering system is hung on ship's hull through a hydraulic cylinder whose working chamber is connected with a gas-hydraulic accumulator. Geometrical parameters of the hydraulic cylinder and charging pressure of the accumulator were so selected as to obtain the force exerted to the piston rod of the cylinder - due to the total weight of the ramp in air and the boat including people - greater than the force due to oil pressure acting on its piston. It means that in the instant when a driving-down boat turns up on the ramp the ramp starts deflecting until the above mentioned forces balance each other. It should be mentioned that the loading due to weight will start lowering the ramp beginning from the instant of immersing the end of the ramp buoyancy element, and the hydraulic force will be greater and greater as a result of increasing pressure in

the accumulator. It makes it possible to decrease the overload which acts on people and the device during launching the boat in heavy sea conditions. The winch motor is fitted with a stopping brake and a hydraulic release. The opening process of the ramp is realized gravitationally at a steady speed controlled by means of a two-way flow controller and, if necessary, a centrifugal brake. The drive and control system of the ramp is complex. It contains additional elements which serve to pull closer and block the ramp in the voyage position.

The ramp together with the line hoisting winch fixed on the ship's hull just before the ramp constitutes a system for hoisting the boats out of water after evacuation trials. The boats are pulled one by one onto the ramp and further onto the slipway where they are placed on the chain lift catches and after that the lift is put into motion. In the instant when a boat is displaced upward to a level assigned on the boat arrangement scale, that is controlled by sensors, the chain lift is automatically stopped until a successive boat is taken out of water and placed on the catches, and after that the mechanism is put into operation, the process is repeated again and again up to the last boat.

To drive the mutually coupled chain lifts four winches fitted with a double-chain wheel and high-torque hydraulic motor equipped with a blocking brake, hydraulic release and, if necessary, additional centrifugal brake, are used. Speed of boat lowering is stabilized and controlled by a two-way flow controller. A schematic diagram of the hydraulic drive and control system is presented in the next section. Fast and efficient evacuation of people from all decks of the ship is ensured by an appropriate form of staircases and a visual and acoustic system for directing the people to the life boats. The concept is based on that the doors leading from the staircases are located just opposite the entrances to the boats. Moreover, an emergency passage connecting successive levels, placed just behind the casing, is provided to facilitate displacing the people in emergency. Moreover, in this area anti-slipping materials are used to prevent people from slipping and falling down.

HYDRAULIC DRIVE AND CONTROL SYSTEM FOR THE PORT-RAMP

The hydraulic drive and control system for the port-ramp is presented in Fig. 7. The main aim of the system is to ensure safe opening the ramp and launching all the boats with people inside, placed on the chain lift, at an appropriate, possibly uniform speed in the conditions of lack of energy supply from ship's power network. Moreover it was assumed that it should be possible to stop and restart the boat launching process from a post on board the ship, and that the system should make it possible to hoist all the boats fitted with standard equipment but only with operators inside, and to close and block the ramp in voyage position.

Run of action during realization of basic operations of the device is presented below.

Before initiation of opening process of the ramp the gate valves 23 and hooks 24 which secure it in voyage position, should be unblocked. The unblocking is realized by switching over the distributors 8c and 7c to the right, that results in oil flowing under pressure from the hydraulic - gas accumulator 17a to the cylinders of the gate valve blockade 23 and hook blockade 24. It should be mentioned that the set of blockades is so designed as to obtain the pressure value necessary to unblock the gate valves lower than that to unblock the hooks, that ensures the desirable sequence of triggering the mechanisms. In normal conditions the accumulator 17a is supplied by the constant capacity pump 2a driven by the electric motor 4a. Starting and stopping process of the motor is controlled by the

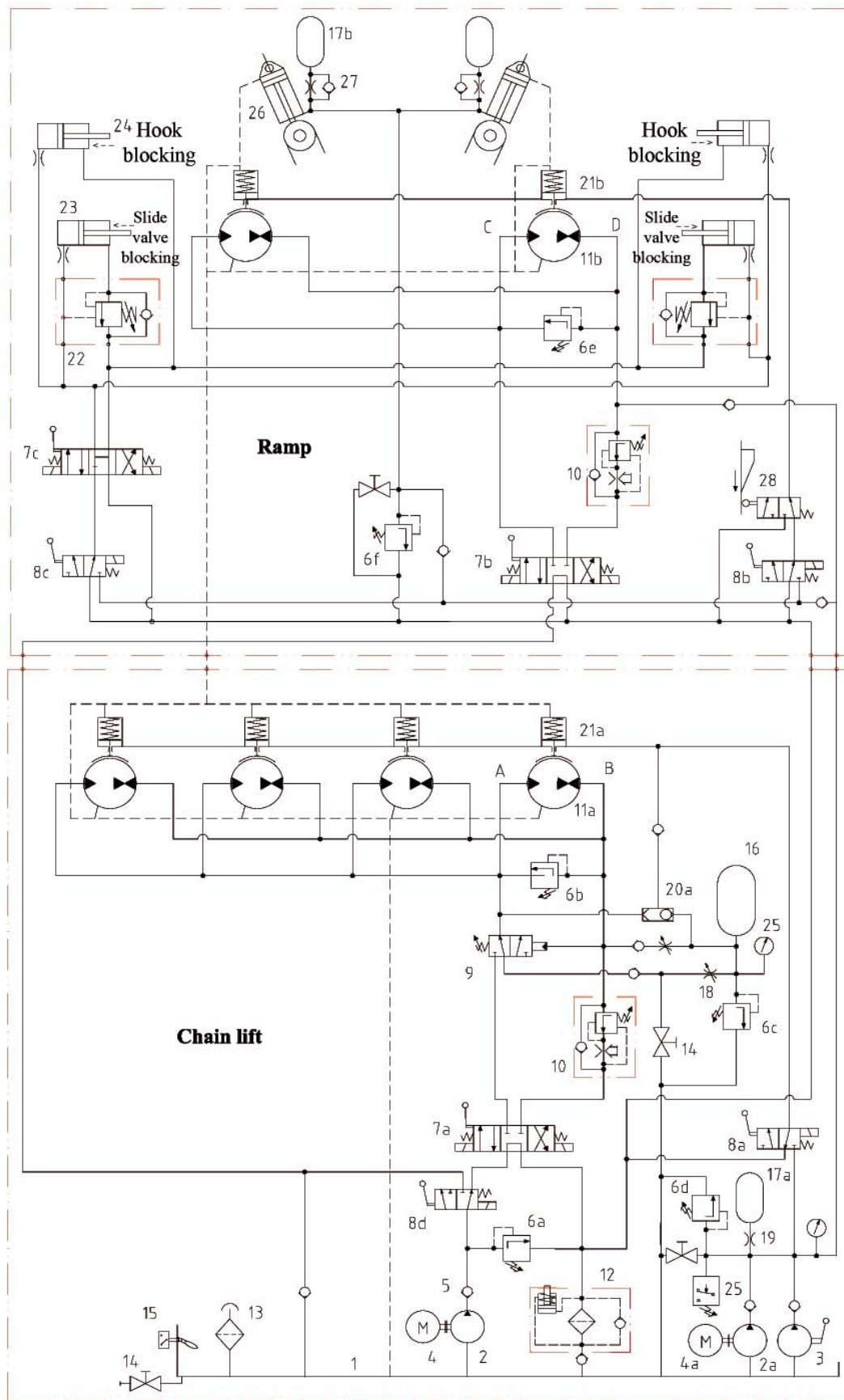

Fig. 7. Schematic diagram of the drive and control system for the stern port-ramp device and life boat chain lift. Notation: **1)** tank, **2)** constant capacity pump, **2a)** hand pump, **3)** hand pump, **4)** electric motor, **4a)** electric motor controlled by pressure transducer, **19)**, **5)** check valves, **6a) – 6e)** overflow valves, **7a) – 7c)** four-way three-position distributors; **8a) – 8d)** three-way two-position distributors, **9)** pressure - controlled three-way two-position distributor; **10a)** and **10b)** two-way flow controllers; **11a)** and **11b)** hydraulic motors of constant absorbing capacity; **12)** returning oil filter; **13)** inlet filter, **14)** cut-off valves, **15)** oil level relay, **16)** and **17a) – 17b)** hydraulic-gas accumulators; **18)** throttle valves; **19)** throttling reducers, **20)** pressure - controlled valves; **21)** hydraulic brake release; **22)** brake valves, manometers; **23)** hydraulic cylinders of gate valves blocking the ramp, **24)** hook blocking hydraulic cylinders, **25)** pressure transducer, **26)** hydraulic cylinder; **27)** throttling check valve, **28)** three-way two-position distributor (limit switch), **A)**, **B)** and **C)**, **D)** stand for main circuit pipe branches of the chain lift and stern ramp, respectively

pressure transducer 25 in such a way as to keep the pressure in the accumulator within a determined range of values. To increase reliability of the device in long-lasting failure conditions the additional hand pump 3 was applied.

The gravitational opening process of the ramp is initiated by switching over the distributors 8b and 7b to the right. The distributor 8b makes oil flowing from the accumulator 17 to the brake releases 21b of the line hoisting winches. Then the distributor 7b connects both the main pipe branches C and D of the motors 11b with the oil tank, that makes suitable circulation of oil during pumping work of the motors while opening the ramp, possible. The two-way flow controller 10b located in the pipe branch D, throttling oil flow, will maintain ramp opening speed on the preset level, causing this way an increase of oil pressure in the upper part of the pipe branch. Owing to this a part of oil will flow from the branch to the accumulator 17a, recovering its charging state lowered by the operations of unblocking and freeing the brakes. Because of a relatively small capacity of the accumulator 17a and the throttling reducer 19 installed in it the charging process does not influence significantly a transient rise of opening speed of the ramp. After reaching by the ramp its nominal opening position the limit switch 28 connects brake releases with the outflow pipe branch and causes the ramp stopping in this position.

After the checking of the ramp opening state and appropriate placing people within the boats, readiness of the boats to launching is controlled and then the devices which secure the lift in its voyage position are released. The lowering of the boats as well as the opening of the ramp is performed by means of gravity forces at switched - off electric motor 4. The putting into motion the chain lifts with the boats is realized by remote switching over the distributors 8a and 7a to the right from the upper boat, or locally from the wheelhouse. It makes oil flowing from the accumulator 17a to the hydraulic brake releases 21a and a sudden rise, caused by external load, of oil pressure in the right pipe branch B of the circuit of the motors 11a. As a result, the distributor 9 is switched over to the left, making oil flow from the tank 1 through the distributors 7a and 9 up to the motors 11a, and their pumping operation due to action of the weight of the boats with people inside, possible. Speed of the motion is stabilized by means of the two-way flow controller 10a. In the first phase of the process the motion will be faster because of a high, loading - dependent oil pressure value as well as due to the fact that a part of the oil pressed from the branch B is gradually drained through the check & throttling valve 18 to the accumulator 16. The accumulator is applied to ensure continuity of lowering motion as well as for the reason that in the phase of placing the last boat on the slipway rollers and its freeing-out from the chain lifts, i.e. when external load of the motors 11a may appear too low to overcome friction forces in the system and to ensure their pumping work. When oil pressure in the branch B drops to its threshold value set by the spring of the distributor 9, it will be switched over to the position of connecting the accumulator (16) with the charging branch (A) of the motors (11) that will ensure continuity of work of the chain lift.

The hoisting operations of the boats out of the water and placing them into the voyage position, e.g. after a trial evacuation, are performed by using ship's power network. The boats are towed-out one by one onto the ramp and farther to the slipway by means of the line hoisting winch placed in the fore part of the slipway.

On the slipway the boats are placed onto the chain lift catches and then the lift is put into motion by switching-on the motor 2 of the pump 4 and switching over the distributor 7a to the left. This way oil pressure in the branch B will be increased,

the distributor 9 switched over to the left as well as the pressure controller switched over into the position connecting the branch in question with the brake releases 21a, that results in starting the hoisting process of the boats. After hoisting the boats to the level which makes it possible to fasten a successive, just taken out of water, life boat, the distributor 7a is switched over into its central position in order to stop motion of the chain lift for a period necessary to fasten the successive boat on the lift, then the chain lift is put into motion and stopped again and again up to the instant of fastening the last boat.

To start the closing process of the port-ramp it is necessary to switched over the distributors 8d and 8b to the right and then the distributor 7b to the left. As a result, the oil from the pump 2 will now flow to the branch D of the motors 11b, and the oil from the accumulator 17a will reach the brake releases 21b and, after freeing the brakes, the line hoisting winch will start in the direction of hauling away the line, closing this way the port - ramp. After its closing, the ramp is to be blocked for ship voyage period that is realized by switching over the distributors 8c and 7c to the right.

FINAL COMMENTS

On the basis of a broader comparative analysis between the elaborated concept of evacuation system and the systems have been applied so far, the following advantages of the novel concept can be presented:

1. A greater safety and comfort of evacuation from the point of view of passengers:
 - easy and safe access to life boats stiffly kept on different levels inside ship's hull without mutual displacements and a sight of rough sea,
 - a lower loading applied to boats and people as a result of lack of panting the boats against ship side and more gentle, bow-forward launching the boats.
2. Facilitation and simplification, hence a shorter duration time, of evacuation:
 - on average, a shorter distance and easier to be covered (now horizontally only) by evacuating persons,
 - simultaneous access to all the boats on particular decks, which makes process of managing and embarking people to boats simpler, faster and facilitated,
 - easiness of process of preparation and initiation of launching all the boats simultaneously and at an uniform speed, that radically speeds up evacuation process,
3. More advantageous technical features:
 - easiness of simultaneous control of readiness of all the boats – as hatchways or doors with glass eyeholes are provided in the casing walls, that makes it possible to find and reach a boat,
 - an integrated drive and control system which makes it possible to start and control evacuation process by a few operators only,
 - collision-free lowering and launching the boats and prompt sailing away from the ship in opposite direction along fairway free of obstacles (e.g. floating ice), that greatly shortens duration of evacuation and increases its safety - boat's engine is started already when the boat goes down along the slipway,
 - application of the ramp capable of increasing its deflection angle, that ensures a relatively gentle contact of a boat going down along it, with water, even in the conditions of an unfavourable ship trim forward and elevation of its end above water,
 - process of opening the port-ramp and lowering the boats runs automatically under action of gravity forces,

- the design of the chain lifts is relatively simple as it contains a smaller number of mechanisms than the systems with side life boats, that increases its reliability and lowers its cost,
 - the life boats applied in the solution in question are similar to those used in free-fall boat systems but they are not to satisfy so high strength requirements, hence they can be cheaper,
 - the device fastening the boat to the chain lift can be released by means of the hydrostatic release, that makes it possible to free the boat and maintain it on sea surface in the case of ship's sinking,
4. Another merits:
- all the evacuation system occupies a relatively small area as the boats are located one by one, and in the relatively least favourable and useful zone of ship,
 - lower resistance to ship motion,
 - elevated aesthetic image of ship.

Bibliography

1. Dymarski Cz., Dymarski P.: *Life saving and rescue appliances for ships – research and design projects* (in Polish). 10th International Scientific Technical Conference on „Safety at Sea and Sea Environment Protection”, 5th Marine Forum, Koszalin - Kołobrzeg 2006, Ed. S. Piocha. - Koszalin, NOT, 2006.
2. Dymarski Cz., Łubiński P.: *Safe evacuation of people from ships - projects realized in the frame of the European Research Project SAFECRAFTS* (in Polish). In: “Development Prospects

of Transport Systems”: 8th Conference on Shipbuilding and Ocean Engineering, Międzyzdroje, June 2006. Publ. Szczecin University of Technology, 2006.

3. Dymarski Cz., Kraskowski M., Sperski M.: *Investigation of motion of the lifeboat lowered from ship's deck*. Polish Maritime Research. - Vol. 13, No.3, 2006.
4. Dymarski Cz., Dymarski P.: *An evacuation system of people from multi-deck ship – passenger carrier in particular* (in Polish). Patent application No. P 379355 of 03.04.2006.
5. Dymarski Cz., Łubiński P., Dymarski P.: *Ramp and chain-lift-launched lifeboats - radical concepts for evacuating cruise ships*. Naval Architect, October 2006.
6. Dymarski Cz.: *A concept of drive and control system of a novel device for people evacuating from large passenger ships*. Polish Maritime Research Vol. 17, No. 4 (67) 2010
7. <http://www.amarnetraffic.com/ais/pl/showallphotos.asp?mmsi=235762000>
8. <http://www.alltechn.com/2009/07/01/royal-caribbean-international/>

CONTACT WITH THE AUTHOR

Prof. Czesław Dymarski
 Faculty of Ocean Engineering
 and Ship Technology,
 Gdańsk University of Technology
 Narutowicza 11/12
 80-233 Gdańsk, POLAND
 e-mail: cpdymars@pg.gda.pl