

Biobatteries and biofuel cells with biphenylated carbon nanotubes

K. Stolarczyk, M. Kizling, D. Majdecka, K. Żelechowska, J. F. Biernat, J. Rogalski, R. Bilewicz

Abstract

Single-walled carbon nanotubes (SWCNTs) covalently biphenylated are used for the construction of cathodes in a flow biobattery and in flow biofuel cell. Zinc covered with a hopeite layer is the anode in the biobattery and glassy carbon electrode covered with bioconjugates of single-walled carbon nanotubes with glucose oxidase and catalase is the anode of the biofuel cell. The potentials of the electrodes are measured vs. the Ag/AgCl reference electrode under changing loads of the fuel cell/biobattery. The power density of the biobattery with biphenylated nanotubes at the cathode is ca. 0.6 mW cm^{-2} and the open circuit potential is ca. 1.6 V. In order to obtain larger power densities and voltages three biobatteries are connected in a series which leads to the open circuit potential of ca. 4.8 V and power density 2.1 mW cm^{-2} at 3.9 V under $100 \text{ k}\Omega$ load. The single biofuel cell shows power densities of ca. $60 \mu\text{W cm}^{-2}$ at $20 \text{ k}\Omega$ external resistance but the open circuit potential for such biofuel cell is only 0.5 V. The biobattery showing significantly larger power densities and open circuit voltages are especially useful for testing novel cathodes and applications such as powering units for clocks and sensing devices.

Keywords Arylated carbon nanotubes Bioelectrocatalysis Dioxygen reduction Glucose oxidation Biofuel cell Laccase

1 Introduction

Progress in nanotechnology has created new direction for the design and development of micro and nanoscale electronic devices suitable for various applications, including industry, medicine or environmental science [1,2]. To keep such miniaturized electronic devices operating for long periods of time, low power sources are required. Especially for medical applications, enzymatic biofuel cells have drawn noticeable attention. Reasons for this interest are based on unique conditions of biofuel cell operation that cannot be met by conventional fuel cells. Important features of biofuel cells are the selectivity of processes occurring at the enzymatically modified electrodes and the ability to operate at room temperature and at pH close to neutral [3,4]. The specificity of the immobilized enzyme allows the construction of such biofuel cells without a membrane separating the anode and cathode compartments, in particular as the open-type devices [5–10]. Therefore membrane-less biofuel cells can be easily miniaturized and, in addition, open construction allows the utilization of oxidant and fuel from the surrounding environment, such as blood tissue [3,11]. Enzymes are also biodegradable, thus they do not pose any threat for organism. According to these benefits biofuel cells are considered as potential source of power for implantable devices such as pacemakers, sensors or micropumps [3,4,12–14].

In glucose/ O_2 biofuel cells, considered in this paper, glucose is electrooxidized at the anode to δ -gluconolactone by glucose oxidase (GOx) and dioxygen is reduced to water at the cathode by laccase. However, engineering problems have to be considered since enzymes have a complex 3D structure. The electron-transferring unit of the enzyme is deeply buried in its structure. Thus, efficient electrical communication between redox active centers of the enzyme and the electrode surface is difficult and demands special approaches to facilitate contact, such as the use of small mediator molecules (dyes, organometallic complexes), conducting polymers, carbon nanotubes, metal nanoparticles or combination of some of these [15]. Another problem to solve in a non-compartmentalized cell is the reduction of dioxygen and oxidation of glucose mixture on the bioanode, as well as on the biocathode. There are several approaches to eliminate the decrease in the power output due to these unwanted reactions. One was the use of modified GOx that is less sensitive to the presence of dioxygen

[16]. Another approach was to use of efficient mediators such as redox polymers containing osmium that result in a more effective electron mediation with GOx than dioxygen. Several membranes were developed using such polymers entrapping both anode and cathode enzymes. One of the best results was achieved by Gao at al., who used osmium polymer mediator combined with carbon nanotubes to bind GOx and bilirubin oxidase to respective electrodes. Due to increased redox site density in the redox polymer form, the power density of cell in 15 mM glucose solution reached as much as $740 \mu\text{W cm}^{-2}$ [17]. Other possibilities of avoiding side reactions include the use of enzymes not sensitive to dioxygen such as glucose dehydrogenase [18] or adding an extra enzyme which catalyzes decomposition of unwanted side products, e.g. catalase which reduces hydrogen peroxide to water. Fransaer at al. suggested using biocathode with combined laccase and catalase to remove the hydrogen peroxide produced in the GOx reaction [19].

In recent years, carbon nanotubes (CNTs) were shown to provide an attractive, versatile and simple route for the development of the bioelectrical devices, because of CNTs significant mechanical strength, excellent electrical conductivity, large surface area and good chemical stability [7,9,20]. Fransaer at al. developed a biofuel cell consisting of a bioanode with GOx and pyrroloquinoline quinone (PQQ) mediator adsorbed on MWCNTs and then deposited by means of AC-electrophoresis on GCE and stabilized by electropolymerized polypyrrole and biocathode with laccase and 2,2'-azino-bis(3-ethylbenzothiazoline-6-sulphonic acid) (ABTS). The biofuel cell studied under air in phosphate buffer solution pH 7.4 containing 10 mM glucose and in human serum at physiological temperature of 37°C gave power densities reaching $110 \mu\text{W cm}^{-2}$ at a cell voltage of 0.167 V in buffer solution and $69 \mu\text{W cm}^{-2}$ in human serum [21]. Yoo at al. developed a complex glucose/ O_2 biofuel cell using GOx, CNTs with polypyrrole (ppy) for the anode and laccase, ppy and ABTS for the cathode. This biofuel cell, due to the extremely expanded catalytic surface, exhibited power density $1390 \mu\text{W cm}^{-2}$ at 0.45 V in 10 mM glucose solution and $690 \mu\text{W cm}^{-2}$ at 0.39 V in blood serum [22].

To fully simulate the behavior of the device in bloodstream the flow working mode of the biofuel cell has to be investigated. These microfluidic biofuel cells exploit the laminar flow in the microchannels which limits convective mixing. The stream of fuel flows in parallel with oxidant without rapid mixing, and the electrochemical reactions are localized at the anode and the cathode within the respective streams. Beneyton at al. reported the development of a glucose/ O_2 fuel cell using laccase and glucose oxidase covalently bound to single-walled carbon nanotube electrodes in a Y-junction microchannel on a glass substrate and such system reached $1.65 \mu\text{W cm}^{-2}$ maximum power density [23]. Another approach was investigated by Soutchcott at al., who used as electrode buckypaper modified with laccase and PQQ-dependent glucose dehydrogenase filled with serum solution to charge pacemaker [24]. Rincon at al. presented flow-operating BFC in which malate and alcohol dehydrogenase (ADH, MDH) and laccase were used. They were coupled with poly-methylene green as mediator, while laccase worked in direct electron transfer regime. Such BFC operated with a circuit voltage of 0.618 V and 0.584 V respectively with maximum volumetric power densities approaching $20 \mu\text{W cm}^{-2}$ [25].

In the present paper we describe the modification of SWCNTs used for the biocathode in order to improve the contact both mechanical and electrical with the active site of laccase. Carbon nanotubes were functionalized with biphenyl groups, by means of amide or sulfonamide bonds. We test this biocathode in a hybrid biofuel cell with Zn anode covered with hopeite. Such a fuel cell with one metallic and one enzymatic electrode is called a biobattery or a hybrid biofuel cell. The term "biobattery" is shorter and generally accepted and, therefore, will be used throughout this paper.

In the biofuel cell, the anode was covered with single-walled carbon nanotubes covalently modified with glucose oxidase and catalase (SWCNT-GOx/Cat). In order to obtain higher



power densities and voltages three biobatteries were connected in a series and tested under flow and stationary conditions in the aerated solutions.

2 Experimental

2.1 Materials and chemicals

The *Cerrena unicolor* C-139 laccase samples lyophilized in vials were obtained as described earlier [26]. The laccase stock solution activity after dissolving the protein powder (from vial) in 1 ml of MilliQ water was 250 U mg⁻¹ of protein.

Glucose oxidase (GOx) and catalase (Cat), both from *Aspergillus niger* as well as bovine albumine were purchased from Sigma (St Louis, USA). Inorganic reagents from POCh (Gliwice, Poland), and organic reagents from Aldrich were used without further purification. The GOx and Cat activities were determined according to the procedures described previously [27,28]. The GOx and Cat activities in working solution were 3900 and 6700 U mg⁻¹ of protein respectively. Single-walled carbon nanotubes (>90%) purchased from CheapTubes.com (Brattleboro, USA) were washed with nitric acid/hydrochloric acid mixture before using for binding GOx and catalase. Pristine SWCNTs were used for the modification procedures. Water was distilled and passed through Milli-Q purification system.

The working laccase solution was prepared by dissolving 1 mg of enzyme in 0.64 ml McIlvaine buffer containing 0.2 M NaNO₃ (pH 5.2). 1% Nafion was prepared by dilution of 5% Nafion in ethanol. 50 μl of 1% Nafion and 50 μl laccase solutions were employed to prepare the mixture deposited on the electrode.

2.2 Electrochemical instrumentations and procedures

Electrochemical experiments were done in three electrode arrangement with Ag/AgCl (KCl satd.) reference electrode, platinum foil as the counter electrode and glassy carbon electrode (GCE, BAS) as the working electrode with surface area of 0.071 cm². Cyclic voltammetry experiments were carried out using ECO Chemie Autolab potentiostat. All electrochemical measurements were done at 22 ± 2 °C. All current densities were calculated using geometrical area of the electrode.

The biofuel cell parameters were examined in air saturated McIlvaine buffer solution (pH 5.2)/0.2 M NaNO₃ and in 0.2 M phosphate buffer (pH 7.0). Scheme 1 shows the configuration of the biobattery and biofuel cell.

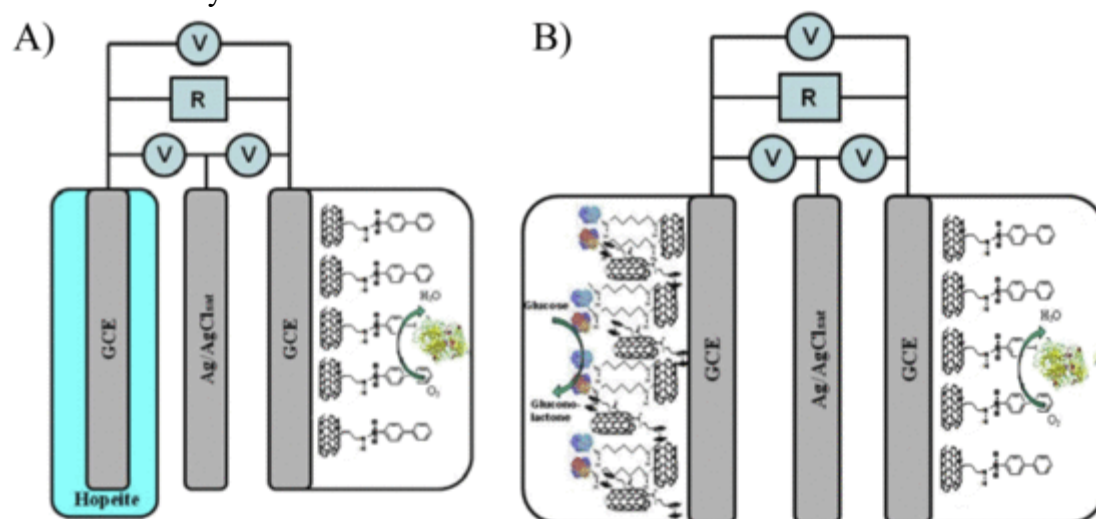

Online view Print view

Scheme 1 Schematic representation of A) the biobattery and B) biofuel cell circuit.

Open circuit voltage (OCV) was measured in all experiments. The cell voltage (V_{cell}), the anode voltage (V_a), the cathode voltage (V_c) were measured under varying loads in the range from 10 MΩ to 1 kΩ. To minimize the power loss caused by dioxygen depletion during the testing the cathode, measurements under each load were restricted to 5 s. The anodes for the

Zn–O₂ hybrid fuel cells (called further biobatteries) were zinc wires (0.25 mm diameter, Goodfellow) coated with a Nafion film by dipping in 0.5% Nafion solution in ethanol and dried for 5 min at ambient conditions. A hopeite layer was formed during the Zn electrode oxidation. The lengths of these electrodes were adjusted so as to obtain the same surface area for both electrodes.

2.3 Synthesis and characterization of modified SWCNTs

The nanotubes modified with biphenyl on the side-walls (material 2 and 3) and at the ends (material 5 and 6) were synthesized according to procedures shown in the [Scheme 2](#) and described in [Supplementary information S-2](#).

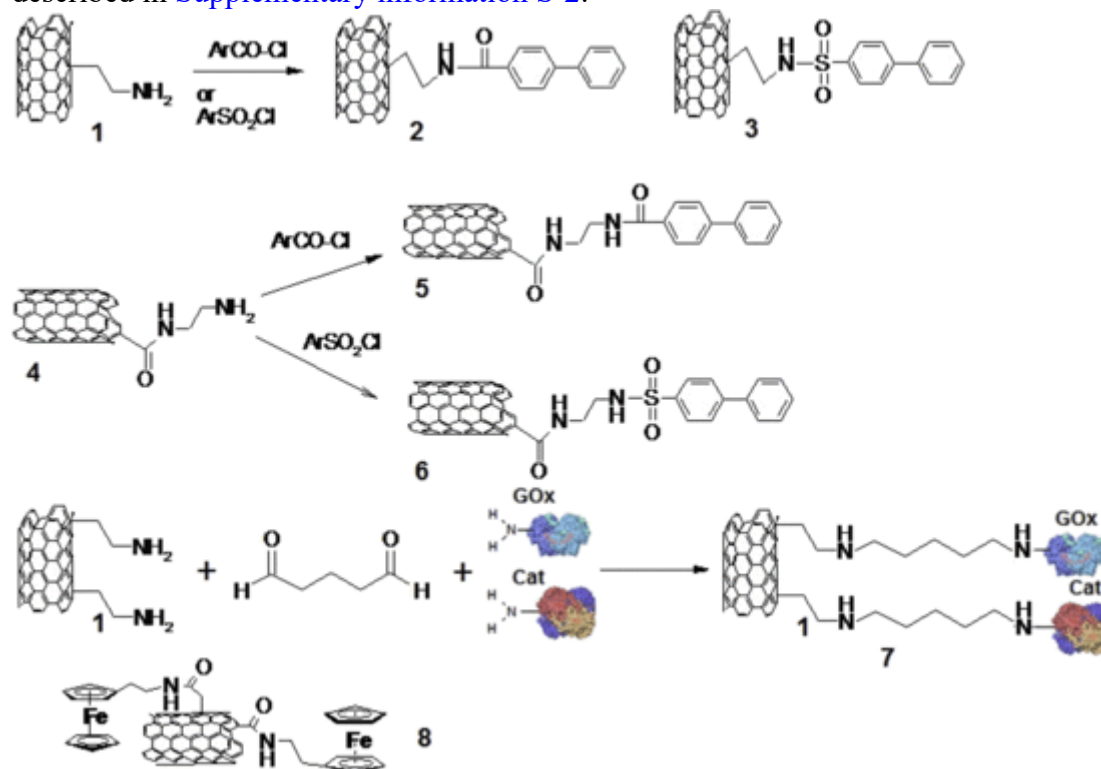

Online view [Print view](#)

[Scheme 2](#) Synthetic schemes for N-biphenyl-aminoethyl SWCNTs (2), and N-4-biphenylsulfonamide SWCNTs (3), and carbon nanotubes used for the bioanode: SWCNTs-GOx/Cat (7) and ferrocene modified SWCNTs (8).

The SWCNTs (8 in [Scheme 2](#)) modified with ferrocenyl groups were synthesized according to procedure described in [Supplementary information S-3](#). The nanotubes bioconjugated with enzymes GOx/Cat and albumin (7 in [Scheme 2](#)) were synthesized according to procedure described in [Supplementary information S-4](#).

2.4 Electrode modification procedures

Biocathodes: Onto GCE surface 10 μl of the suspension of modified SWCNTs in ethanol (4 mg ml^{-1}) was dropped. After drying in air, 10 μl of laccase in Nafion casting solution was pipetted onto the electrode and allowed to dry.

Bioanodes: GCE surface was covered with the mixture of SWCNTs modified with two enzymes, GOx and Cat (7 in [Scheme 2](#)) and ferrocene (8 in [Scheme 2](#)). The mixture consisted of 5 μl suspension of enzymatic SWCNTs (7) in water (15 mg ml^{-1}) and 5 μl ferrocene SWCNTs (8) suspension in ethanol (4 mg ml^{-1}) and allowed to dry.

3 Results and discussion

3.1 Electrochemical studies

We have shown earlier that nanostructuring of the cathode with SWCNTs and placing on it a Nafion film containing laccase leads to a decrease of the overpotential of dioxygen reduction

by as much as ca. 1.2 V vs. Ag/AgCl compared to reduction potential of dioxygen at a non-modified glassy carbon electrode (GCE) [5,6]. At the plain GCE, the reduction potential is ca. -0.6 V vs. Ag/AgCl both in the absence and presence of laccase film. In order to increase the current efficiency of the system, the GCEs were structured here with nanotubes covalently derivatized with the biphenyl-moiety attached to the nanotubes using 4 different linkers (2,3,5 and 6 in Scheme 2). Cyclic voltammograms were recorded using these electrodes covered with laccase in the Nafion layer in deoxygenated and saturated with dioxygen McIlvaine buffer solutions containing 0.2 M NaNO₃ (pH 5.2). The dioxygen reduction wave appeared at the same potential as in case of the electrode covered with pristine carbon nanotubes, however, the current density was significantly larger (Fig. 1). The largest current density was obtained in case of wall-derivatized SWCNTs 3 (Table 1). The catalytic reduction current density measured at 0.2 V was 484 $\mu\text{A cm}^{-2}$. Thus, the SWCNTs 3 were used further on for the cathode in the biobattery and biofuel cell.

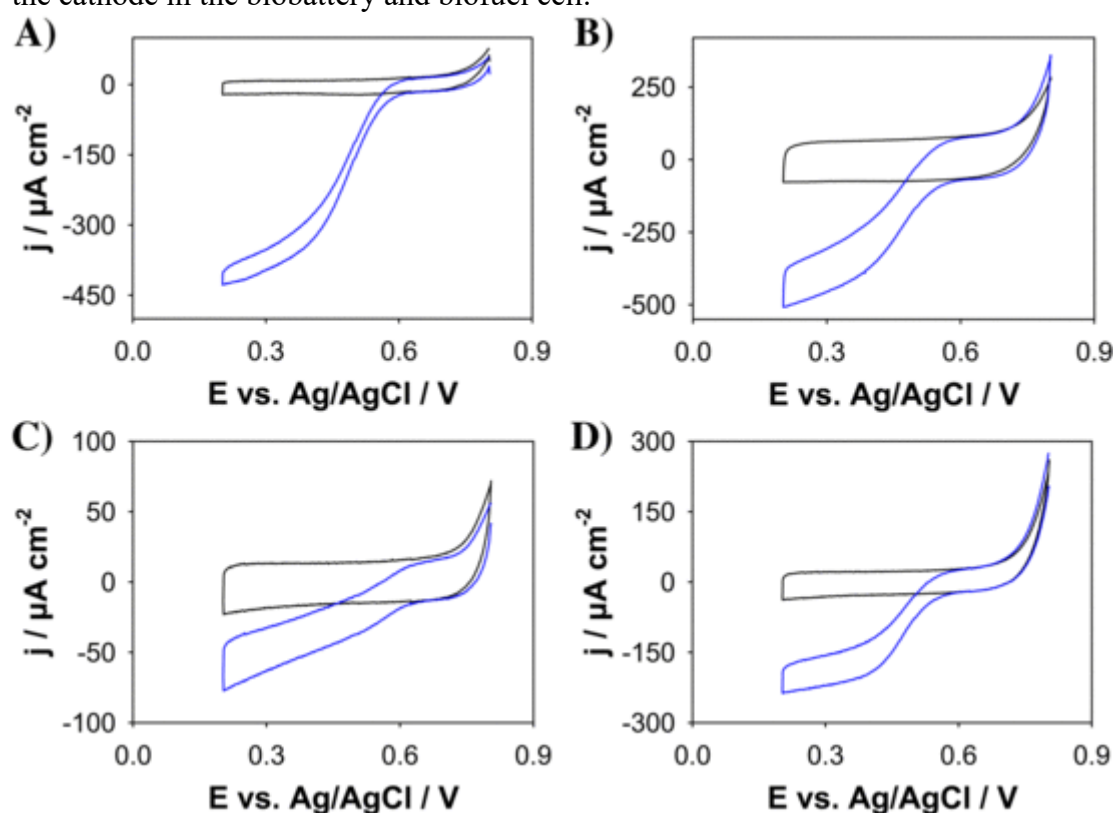

Online view Print view

Fig. 1 Cyclic voltammograms recorded using electrodes modified with SWCNTs: (A) 2, (B) 3, (C) 5 and (D) 6 all covered with a Nafion layer containing laccase in (-) deoxygenated and (-) saturated with dioxygen McIlvaine buffer solution (pH 5.2)/0.2 M NaNO₃, scan rate 1 mV s⁻¹.

Table 1 Current density measured at 0.2 V for the electrodes covered with modified SWCNTs and Nafion film containing laccase in deoxygenated (j_{beg}) and saturated with dioxygen (j_{cat}) McIlvaine buffer solution (pH 5.2)/0.2 M NaNO₃.

SWCNTs used for cathode modification	j_{beg} [$\mu\text{A cm}^{-2}$]	j_{cat} [$\mu\text{A cm}^{-2}$]	$j_{\text{cat}} - j_{\text{beg}}$ [$\mu\text{A cm}^{-2}$]
2	-27 ± 7	-425 ± 3	-398 ± 10
3	-68 ± 13	-484 ± 33	-416 ± 20
5	-24 ± 2	-81 ± 5	-57 ± 3
6	-32 ± 9	-228 ± 13	-196 ± 4

The electrodes covered with SWCNTs 3 giving the largest laccase catalyzed currents were tested in a flow and stationary air–biobattery. The power density–voltage and current density–voltage dependencies of the biobattery were obtained by applying different external resistances in the range from 10 M Ω to 1 k Ω to the circuit. To enable monitoring of the changes in the potential of each of the electrodes, the biobattery was studied in a three electrode arrangement containing additionally the reference electrode Ag/AgCl (KCl sat) (Scheme 1). Plots of power density and current density vs. cell voltage are presented in Fig. 2. V_{cell} is the cell voltage, V_a and V_c are the voltages between the Zn anode or biocathode and reference electrode. In the Fig. 2B the currents at each of the electrodes are plotted vs. potential measured against Ag/AgCl reference electrode. The open circuit potential measured for the biobattery containing SWCNTs 3 was ca. 1.6 V both in the flow and stationary system. The maximum power density is 0.6 mW cm⁻² at 0.921 V under 20 k Ω load for both systems. In the flow system the cathode potential is more stable in time because dioxygen is transported to the electrode surface more efficiently. The zinc anode covered with hopeite remains very stable under all working conditions so any changes in the cell voltage output during biobattery functioning have to be ascribed to the biocathode. The biocathode is stable at large loads, i.e. when small current flows. In the high current region the cathode potential decreases rapidly due to dioxygen diffusion limitations (Fig. 2B). It seems, that the biobattery is fully operative in the range of the ohmic loads 10000–10 k Ω , while under lower resistances hence more demanding conditions (currents larger than ca. 1000 μ A cm⁻²), the cathode is acting as a simple carbon nanotube modified electrode reducing dioxygen at potentials close to 0 V vs. Ag/AgCl reference. The tri–electrode system is shown here to be very convenient for monitoring such changes of working potentials on each of the electrodes used in the fuel cell.

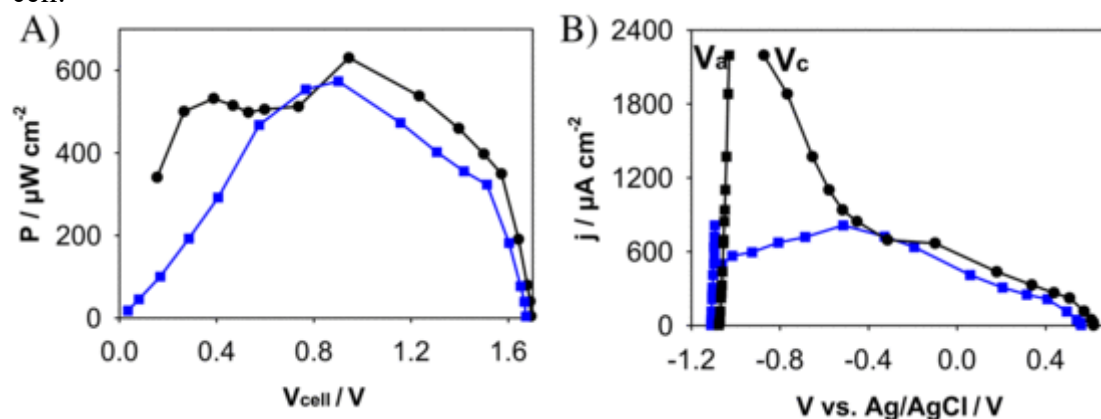

Online view Print view

Fig. 2A) Dependence of power density on biobattery voltage and B) current density on potentials of cathode, V_c and anode, V_a potentials vs. Ag/AgCl (KCl sat) for (●) flow rate 24 ml min⁻¹ and (■) stationary system. Electrodes: cathode modified with SWCNTs 3 and laccase in Nafion film, and zinc wire anode. Electrolyte: air-saturated McIlvaine buffer with 0.2 M NaNO₃ (pH 5.2).

Larger power densities and voltages can be obtained by connecting three biobatteries in a series (Fig. 3) and for such connection the open circuit potential was ca. 4.8 V and maximum power density under 100 k Ω load was 2.1 mW cm⁻² at 3.9 V. The system can powered small measuring devices for example timers for more than 10 days.

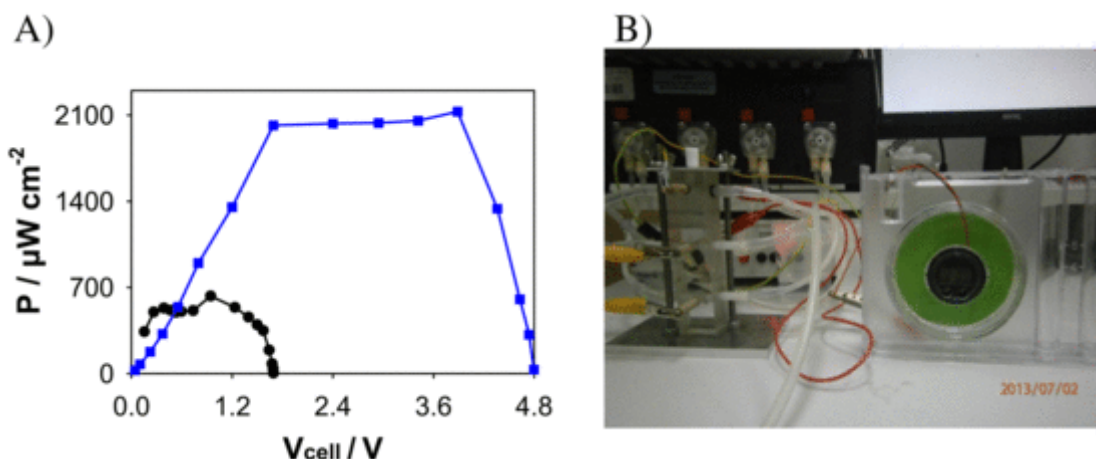

Online view Print view

Fig. 3A) Dependence of power density on cell voltage for (●) single biobattery (■) 3 biobatteries in a series in a flow system. Cathode modified with SWCNTs 3 and Nafion film with laccase. Anode: Zn electrode. B) System of 3 biobatteries in a series powering a clock. Electrolyte: air saturated McIlvaine buffer with 0.2 M NaNO_3 (pH 5.2). Solution flow rate 24 ml min^{-1} .

The electrode modified with SWCNTs 3 was tested also in a full biofuel cell under flow and stationary conditions. In the biofuel cell arrangement, the bioanode was modified with ferrocene SWCNTs 8 and SWCNTs bioconjugates with glucose oxidase and catalase, (SWCNTs 7) (Fig. 4). The dependence of ferrocene oxidation current on glucose concentration was observed. Hydrogen peroxide (H_2O_2) is not interfering in the process because it undergoes disproportionation to water (H_2O) and dioxygen (O_2) catalyzed by catalase covalently bound to the same nanotubes. The buffer was changed to phosphate (pH 7.0) to be close to the pH conditions in the body. The biofuel cell was tested also in the three electrode including the reference electrode Ag/AgCl (KCl_{sat}). The plots of power density vs. cell voltage, and current densities at each of the electrodes vs. potential (measured in parallel against Ag/AgCl (KCl_{sat})) are presented in Fig. 4. The open circuit potential of this system was ca. 0.5 V. The maximum of power density $63 \mu\text{W cm}^{-2}$ was obtained at 0.3 V under $20 \text{ k}\Omega$ external resistance. The parameters of the biofuel cells described in the present paper are presented in Table 2.

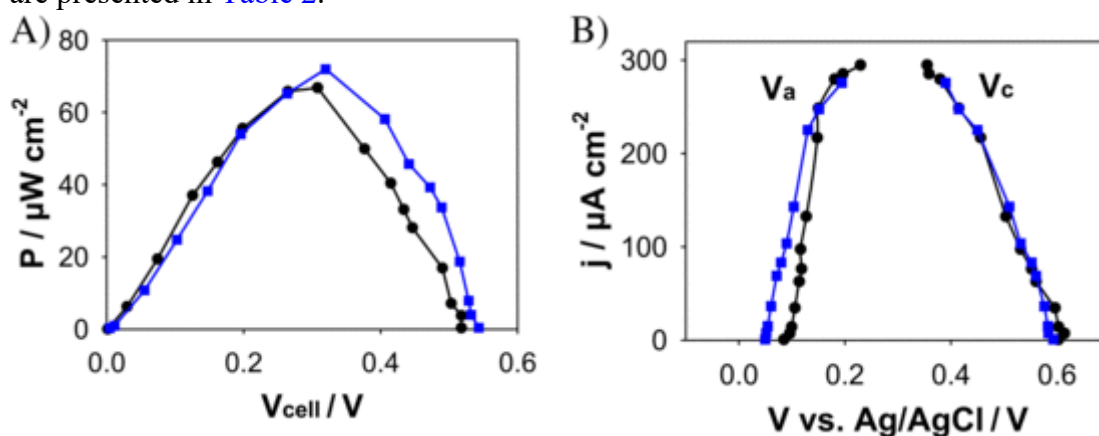

Online view Print view

Fig. 4A) Dependence of power density on biofuel cell voltage and B) current density on potential of cathode, V_c and anode, V_a vs. Ag/AgCl (KCl_{sat}) reference electrode, under (●) flow and (■) stationary conditions. Biocathode modified with SWCNTs 3 and bioanode with SWCNTs 8 and 7. Electrolyte: air saturated 0.2 M phosphate buffer solution (pH 7.0) containing 250 mM glucose, flow rate 24 ml min^{-1} .

Table 2 Comparison of biobattery and biofuel cell parameters under 20 kΩ external resistance.

Anode/cathode	Conditions	P [$\mu\text{W cm}^{-2}$]	E [V]	OCV [V]
Zinc wire/SWCNTs 3	Flow	600 ± 70	0.92 ± 0.05	1.63 ± 0.06
	Stationary	565 ± 70	0.90 ± 0.05	1.58 ± 0.12
Mixture of SWCNTs 7 and 9/SWCNTs 3	Flow	58 ± 8	0.29 ± 0.02	0.50 ± 0.03
	Stationary	63 ± 9	0.28 ± 0.03	0.49 ± 0.05

4 Conclusions

We compared the efficiencies of biobattery and full enzymatic fuel cell that employ biphenylated carbon nanotubes to connect laccase with the conducting support. We simultaneously monitor under external load: the cell power and the potential of each of the electrodes vs. Ag/AgCl reference electrode. This immediately shows which electrode determines the efficiency of the cell. The anodes used in the present work are more stable than the cathodes. The maximum power density, 0.6 mW cm^{-2} was obtained for the biobattery with zinc wire anode and GCE cathode covered with N-4-biphenylsulfonyl SWCNTs and laccase. The open cell voltage for the hybrid biobattery due to negative value of Zn/Zn²⁺ redox potential ($E^0 = -0.76 \text{ V vs. NHE}$) exceeds 1.6 V, thus, it is significantly larger than that of glucose-O₂ biobattery.

It is difficult to compare the performance of biocathodes and biobatteries reported in the literature, since the devices are assessed under very different conditions and the data are not standardized. The generally accepted way of showing the parameters of the biobattery and biofuel cell are current and power densities, hence divided by geometrical area of the electrodes. While it was informative for monolayer or even very thin film covered electrodes it is not helpful in comparing in the case of thick layers of matrix with incorporated enzyme where the whole volume of the film and not only the surface is acting as the working electrode. In particular, when this 3D matrix is an electrode itself [29], or when the electrode forms a 3D membrane through which air or dioxygen is delivered to the cell from the environment or another compartment [30].

We compare recent results (selected to show different approaches) in Table 3.

Table 3 Parameters of selected CNTs-based biobatteries reported recently in the literature compared to biobattery described in this study.

Type of electron transfer	Cathode enzyme	Fuel	Power density (operating voltage) [$\mu\text{W cm}^{-2}$ (V)]	OCV [V]	O ₂ reduction current density, j_{cat} [$\mu\text{A cm}^{-2}$]	Comments	Ref.
MET	Laccase	Air	10 (0.7)	1.5	45	Nanotube inks used for printing laccase-ABTS layer. A cell potential between 0.8 and 0.6 V was maintained for 3 days	[31]
MET	Laccase	O ₂ purged through the solution	275 (1.5)	1.25	400	Enzymes immobilized on vertically aligned CNTs using different methods: (a) adsorption from solution, (b) encapsulation in drop-	[32]

Type of electron transfer	Cathode enzyme	Fuel	Power density (operating voltage) [$\mu\text{W cm}^{-2}$ (V)]	OCV [V]	O ₂ reduction current density, j_{cat} [$\mu\text{A cm}^{-2}$]	Comments	Ref.
						coated hydrophobic silicate film and (c) encapsulation in drop-coated silicate film preceded by non covalent functionalization of the CNTs with 1-pyrenesulfonic acid sodium salt (PSA)	
DET	Laccase	O ₂ saturated	440 (0.5)	1.76	270	Laccase was crosslinked via glutaraldehyde to graphite and graphitized carbon cloth	[33]
DET	Laccase	O ₂ saturated	1000	1.5	388	Arylated SWCNTs were dropped on glassy carbon electrode, then laccase solution with nafion was deposited	[5]
DET	Billirubin oxidase	O ₂ passing through the modified electrode	5250 (0.4)	1.75	2100	Billirubin oxidase was immobilized by sol – gel method on Toray paper with SWCNTs and nafion. Saturated solution flow through porous membrane connected with compartment filled with oxygen	[30]
DET	Laccase	O ₂ purged	1000 (0.8)	1.5	580	Laccase was covalently immobilized on SWCNTs by aminoethyl residues	[34]
DET	Laccase	O ₂ saturated	5100 (0.6)	1.71	910	Thick films of SWCNTs with covalently bound analogues of natural substrates of laccase to orient the enzyme on the electrode	[35]
DET	Laccase	Air saturated solution in laminar flow	600 (0.9)	1.63	484 (O ₂) 100 (air)	In this study	



Our biobattery shows relatively high power and working potential and has the advantage of using air instead of dioxygen. Application of biphenylated carbon nanotubes leads to the increase of the number of laccase molecules in electrical contact with the electrode and no mediators are needed. The biobattery is found useful both under solution flow and stationary conditions which allowed to show dioxygen supply to the cathode as the limiting factor under stationary conditions.

Usually the parameters of the enzymatic fuel cells are established based on potentiostatic or galvanostatic measurements [30]. This obviously is far from the practical application conditions, thus, in our approach the external resistances of different values are applied to the circuit and under these conditions the potentials of each of the electrodes and voltage of the whole cell are measured. Also stabilities of the cell parameters are checked under working conditions, hence under defined load and not at open circuit potential as often is the case.

Both biobatteries and biofuel cells are currently intensively investigated since their properties need further improvement. Advantage of biobattery is their much higher power and simple cell construction. On the other hand, slow oxidation of Zn anode is not favorable if the device is designed for using in the living organism. The biobattery is a reasonable solution as an external powering unit.

Full biofuel cell is totally biocompatible and also is biodegradable. Only natural fuels and substrates are used e.g. glucose and dioxygen [21,36–41]. For the single fully enzymatic biofuel cell, with SWCNTs bioconjugated with glucose oxidase and catalase at the anode, the power density was ca. $60 \mu\text{W cm}^{-2}$ and the open circuit potential was 0.5 V. Further increase of the power output of the cell can be achieved by using few fuel cells connected in a series, as shown in our paper. Still, the current and potential of a single bioanode has to be improved and work in this direction is continued in many laboratories.

Acknowledgments

This work was supported by the Polish Ministry of Sciences and Higher Education and The National Center for Research and Development (NCBiR), grant NR05-0017-10/2010 (PBR-11). K. Żelechowska and J.F. Biernat thank for support through grant N N204 214 639 from Polish Ministry of Sciences and Higher Education

Appendix A Supplementary data

Supplementary data related to this article can be found at <http://dx.doi.org/10.1016/j.jpowsour.2013.10.074>.

References

- [1] S.C. Barton, J. Gallaway, P. Atanassov, *Chem. Rev.* 104, 2004, 4867–4886
- [2] J.A. Cracknell, K.A. Vincent, F.A. Armstrong, *Chem. Rev.* 108, 2008, 2439–2461
- [3] A. Heller, *Phys. Chem. Chem. Phys.* 6, 2004, 2092–16
- [4] I. Willner, Y.M. Yan, B. Willner, R. Tel-Vered, *Fuel Cells* 9, 2009, 724
- [5] K. Stolarczyk, D. Łyp, K. Żelechowska, J.F. Biernat, J. Rogalski, R. Bilewicz, *Electrochim. Acta* 79, 2012, 7481
- [6] K. Stolarczyk, M. Sepelowska, D. Łyp, K. Żelechowska, J.F. Biernat, J. Rogalski, K.D. Farmer, K.N. Roberts, R. Bilewicz, *Bioelectrochemistry* 87, 2012, 1541–63
- [7] M.T. Meredith, M. Minson, D. Hickey, K. Artyushkova, D.T. Glatzhofer, S.D. Minteer, *ACS Catal.* 1, 2011, 1683–1690
- [8] M. Sosna, J.M. Chrétien, J.D. Kilburn, P.N. Bartlett, *Phys. Chem. Chem. Phys.* 12, 2010, 10018–10026
- [9] M. Sosna, L. Stoica, E. Wright, J.D. Kilburn, W. Schuhmann, P.N. Bartlett, *Phys. Chem. Chem. Phys.* 14, 2012, 11882–11885
- [10] M. Karańkiewicz, J.F. Biernat, J. Rogalski, K.P. Roberts, R. Bilewicz, *Electrochim. Acta* 2013, submitted for publication



- [11] R. Bilewicz, M. Opałło, A. Więckowski, J. K. Norskov, *Fuel Cell Science: Theory, Fundamentals and Biocatalysis* 2010 John Wiley & Sons, Inc Hoboken, New Jersey 169214
- [12] J. R. Windmiller, J. Wang, *Electroanalysis* 25(20) 1329-46
- [13] M. Zhou, N. Zhou, F. Kuralay, J. R. Windmiller, S. Parkhomovsky, G. Valdes-Ramirez, E. Katz, J. Wang, *Angew. Chem. Int. Ed.* 51(20) 12268-62689
- [14] P. Cinquin, C. Gondran, F. Giroud, S. Mazabrard, A. Pellissier, F. Boucher, J. P. Alcaraz, K. Gorgy, F. Le nouel, S. Mathe, P. Porcu, S. Cosnier, *PLoS One* 5(20) 1017
- [15] D. Leech, P. Kavanagh, W. Schuhmann, *Electrochim. Acta* 84(20) 12223-234
- [16] E. Katz, I. Willner, A. B. Kotlyar, *J. Electroanal. Chem.* 479 1999-6468
- [17] F. Gao, L. Viry, M. Maugey, P. Poulin, N. Mano, *Nat. Commun.* 12(0) 1017
- [18] L. Deng, C. Chen, M. Zhou, S. Guo, E. Wang, S. Dong, *Anal. Chem.* 82(20) 104283-4287
- [19] M. Amman, J. Fransaer, *Biosens. Bioelectron.* 39(20) 13274-281
- [20] K. Gong, Y. Yan, M. Zhang, L. Su, S. Xiong, L. Mao, *Anal. Sci.* 21(20) 051383-1393
- [21] M. Amman, J. Fransaer, *Biotechnol. Bioeng.* 109(20) 121601-1609
- [22] J. Kim, K. H. Yoo, *Phys. Chem.* 15(20) 13351-3517
- [23] T. Beneyton, I. P. M. Wijaya, C. B. Salem, A. D. Griffiths, V. Taly, *Chem. Commun.* 49(20) 131094-1096
- [24] M. Southcott, K. MacVittie, J. Halamek, L. Halamkova, W. D. Jemison, R. Lobel, E. Katz, *Phys. Chem. Chem. Phys.* 15(20) 136278-6283
- [25] R. A. Rincon, C. Lau, H. R. Luckarift, K. E. Garcia, E. Adkins, G. R. Johnson, P. Atanassov, *Biosens. Bioelectron.* 27(20) 11321-36
- [26] B. Rola, M. Karaśkiewicz, D. Majdecka, I. Mazur, R. Bilewicz, S. Ohga, J. Rogalski, *J. Fac. Agric., Kyushu Univ.* 58(20) 13231-238
- [27] J. Rogalski, J. Fiedurek, J. Szczodrak, K. Kapusta, A. Leonowicz, *Enzyme Microb. Technol.* 101(9) 8850-8511
- [28] J. Rogalski, J. Fiedurek, A. Gromada, *Acta Microbiol. Pol.* 47(19) 983-143
- [29] A. Zebda, C. Gondran, A. Le Goff, M. Holzinger, P. Cinquin, S. Cosnier, *Nat. Commun.* 22(0) 113703-75
- [30] A. Złoczewska, M. Jönsson-Niedziolka, *J. Power Sources* 228(20) 13104-111
- [31] M. Smolander, H. Boer, M. Valkiainen, R. Roozeman, M. Bergelin, J. E. Eriksson, X. C. Zhang, A. Koivula, L. Viikari, *Enzyme Microb. Technol.* 43(20) 08931-02
- [32] A. Złoczewska, M. Jönsson-Niedziolka, J. Rogalski, M. Opallo, *Electrochim. Acta* 56(20) 113947-3963
- [33] U. B. Jensen, S. Lorcher, M. Vagin, J. Chevallier, S. Shipovskov, O. Koroleva, F. Besenbacher, E. E. Ferapontova, *Electrochim. Acta* 62(20) 12218-226
- [34] E. Nazaruk, M. Karaśkiewicz, K. Żelechowska, J. F. Biernat, J. Rogalski, R. Bilewicz, *Electrochim. Commun.* 14(20) 12677-0
- [35] M. Karaśkiewicz, D. Majdecka, A. Więckowska, J. F. Biernat, J. Rogalski, R. Bilewicz, *Electrochim. Acta* 2013 in press
- [36] T. Miyake, K. Haneda, S. Yoshino, M. Nishizawa, *Biosens. Bioelectron.* 40(20) 13454-9
- [37] I. W. Schubart, G. Gobel, F. Lisdat, *Electrochim. Acta* 82(20) 12224-232
- [38] D. MacAodha, P. O. Conghaile, B. Egan, P. Kavanagh, D. Leech, *ChemPhysChem* 14(20) 132302-2307
- [39] A. Korania, A. Salimi, *Biosens. Bioelectron.* 50(20) 13186-193
- [40] M. Shao, M. N. Zafar, M. Falk, R. Ludwig, C. Sygmund, C. K. Peterbauer, D. A. Guschin, D. MacAodha, P. Conghaile, D. Leech, M. D. Toscano, S. Shleev, W. Schuhmann, L. Gorton, *Chem. PhysChem* 14(20) 132260-2269
- [41] F. Giroud, S. D. Minteer, *Electrochim. Commun.* 34(20) 13157-160