

## Buckling Analysis of Cold Formed Silo Column

KAROL REJOWSKI

*Buildings Structures and Material Engineering  
Gdańsk University of Technology  
rejowskikarol@wp.pl*

PIOTR IWICKI

*Department of Structural Mechanics  
Gdańsk University of Technology  
piwicki@pg.gda.pl*

Received (20 January 2015)

Revised (26 January 2016)

Accepted (21 February 2016)

The paper is devoted to stability analysis of different models of steel cold formed silo column. The steel cylindrical silos are often composed of corrugated walls and vertical open-sectional columns uniformly placed along the silo circumference. Both the whole 3D silo, a simplified model consisting of one column with a part of the silo walls, and a single column resting on elastic foundation provided by the silo walls were analyzed. Linear buckling analyses were carried out using commercial FE package ABAQUS. Axisymmetric and non-axisymmetric loads imposed by a bulk solid following Eurocode 1 were considered. The calculated buckling loads of 1D column model were compared with the permissible one given by Eurocode 3 and with results found for the whole silo and a single column on elastic foundation modeled by shell elements.

*Keywords:* buckling load, cylindrical orthotropic shell, columns, Eurocode approach.

### 1. Introduction

Silos can be built of thin-walled horizontally corrugated curved sheets strengthened by vertical columns. The wall sheets carry circumferential tensile forces resulting from horizontal wall pressure and vertical columns carry compressive forces exerted by wall friction from a bulk solid. The silo columns are therefore vulnerable to buckling. For a small column distance the silo wall can be treated as an equivalent orthotropic shell. The state of the art of the available recent knowledge on the stability design of steel shells was summarized in [1–4]. The theory for eccentricity

stiffened orthotropic cylinders was studied in paper [2]. Extensive measurements of initial geometrical imperfections of stringer-stiffened cylinders were described in [3]. The recent knowledge on thin-walled elastic shells with a homogenized regular arrangement of rings and stringers was summarized in [4].

Currently some papers have dealt with the design of silos with corrugated walls and sparsely distributed vertical stiffeners. Numerical linear and non-linear quasi-static analyses with initial geometric imperfections for a slender silo was performed in [5]. The paper [6] dealt with failure of large cylindrical silos and proposed repair methods based on sensitivity analyses. A bending theory for cylindrical orthotropic shells with normal and shear pressures was presented in research [7]. The buckling behavior of different corrugated wall silos with vertical stringers was analyzed with a dynamic approach in [8].

In the design practice it is necessary to use a simple models instead of the analysis of the whole 3D silos. The Eurocode 3 [9] provides two approaches related to global linear buckling of structure depending upon the silo column distance  $d_s$ . For a small column distance  $d_s < d_{s,max}$  the silo wall is treated as the equivalent orthotropic shell (method "A"). For a higher column distance  $d_s > d_{s,max}$ , the characteristic buckling load bearing capacity is based on the buckling formula for a single column resting on the elastic foundation provided by the wall bending stiffness (method "B"). The 3D FE calculation results presented in [5, 8, 10] evidently show that the Eurocode (2009) [9] approach may provide significantly too conservative outcomes for silos with corrugated sheets and columns. An improvement of Eurocode 3 [9] buckling formula for the silo design basing on results of an approximation of numerical finite element (FE) analyses was presented in research [10]. Different method based on application of formula for orthotropic shell theory with a reduction factor within the range of method "B" was proposed in [8].

The aim of the present paper is to propose a simplify model of the silo composed of horizontally corrugated sheets strengthened by vertical columns based on the linear buckling analysis for a silo with sparsely distributer columns (within the range of application of method "B"). In the present research a simplified model consisting of one column with a part of the silo walls and a single column resting on elastic foundation provided by the silo walls of stiffness according to [11] are compared with the buckling analysis of the whole silo and to existing Eurocode 3 formula. The buckling analysis of the silo with different number of columns allowed to set a range of application of the proposed method.

## 2. Silo description

The numerical calculations were carried out with a real cylindrical metal silo belonging to a silo battery (Fig. 1). The height of a silo was  $H = 17.62$  m and its diameter  $D = 8.02$  m ( $H/D = 2.2$ ). The silo mantle consisted of 21 horizontally corrugated sheets  $890 \text{ mm} \times 2940 \text{ mm} \times 0.75 \text{ mm}$  based on a foundation slab. The silo was strengthened by 18 vertical columns composed of open thin-walled profiles with a varying cross-section in the form of the 'C' (above 5m) and 'V' (at height 0-5m) - shape and thickness ( $t = 1.5\text{-}4 \text{ mm}$ ) along the column height uniformly placed along the silo circumference at the constant distance of  $d_s = 1.4$  m. The columns were connected to the wall sheets by screws.

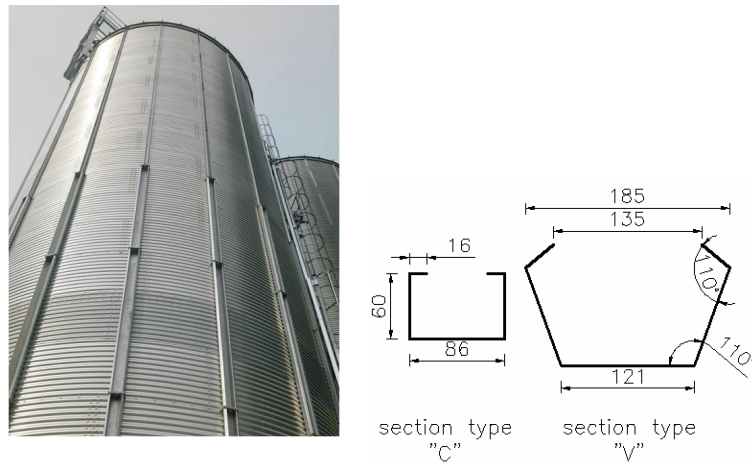

**Figure 1** Metal cylindrical silos with corrugated walls and 18 vertical columns at distance of 1.4 m (height  $H = 17.62$  m and diameter  $D = 8.02$  m)

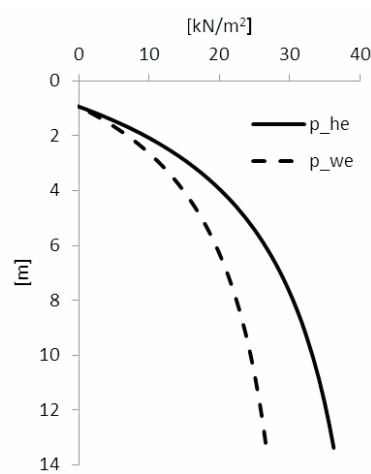

**Figure 2** Vertical wall frictional traction and horizontal wall pressure in silo during emptying according to Eurocode 1 [12] ( $p_w$  – vertical frictional traction,  $p_h$  – horizontal normal pressure)

The corrugation had 76 mm pitch and 18 mm depth. The silo roof was made from metal sheets inclined under an angle of  $25^\circ$  to the horizontal and stiffened by 36 radial beams.

The silo wall loads induced by maize were calculated according to Eurocode 1 [12]. During axisymmetric emptying, the standard maximum wall normal and shear stress in the bin were  $p_h = 30.52$  kPa and  $p_w = 19.38$  kPa, respectively. When

considering a possible non-symmetric emptying, they increased up to  $p_h = 36.26$  kPa and  $p_w = 26.68$  kPa (Fig. 2). In numerical analyses it was assumed that the load level according Eurocode 1 [12] was the reference value, i.e. the load factor  $\lambda$  was always related to the wall shear stress of  $p_w = 26.68$  kPa.

In our previous numerical analysis [8] the shell nonlinear static and dynamic analysis with geometrical and material nonlinearity of the above described silo was presented. The silo shell model consisted of 884'880 S4R elements [8]. Then the model of single silo column resting on elastic foundation of different stiffness was again investigated in [11, 13] (Fig. 3). The results of the analysis [11, 13] revealed that for the foundation stiffness described by Eurocode 3 [9] and according formula proposed in [11] the global buckling occurred.

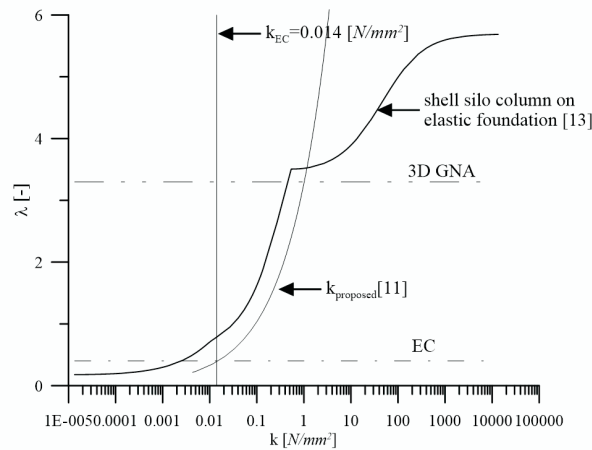

**Figure 3** Evolution of column buckling load factor against lateral foundation stiffness  $k$  [11, 13]

Present research is a continuation of work [8, 11, 13]. The above described silo was again analyzed with variable number of columns on the silo perimeter from 3 to 50. Due to the fact that the silo shell model required huge amount of finite elements the silo simplified model was introduced. The silos walls were modeled as so-called equivalent orthotropic shell with the stiffness according to [9] and the silo columns were modeled with 2-node beam elements (B33). Such model of different silo was verified with the results for the shell 3D model in [10]. The analysis was performed by commercial program ABAQUS [14]. The element size in the model was 0.07 m  $\times$  0.07 m for the silo wall and 0.07 m for the beam elements in silo columns. The number of the S4 elements in silo wall was 90'720. Number of the B33 elements in a single silo columns was 4'563. Total number of the finite elements in whole silo was 91'476 for silo with three columns and 95'256 for silo with fifty columns (Fig. 4a).

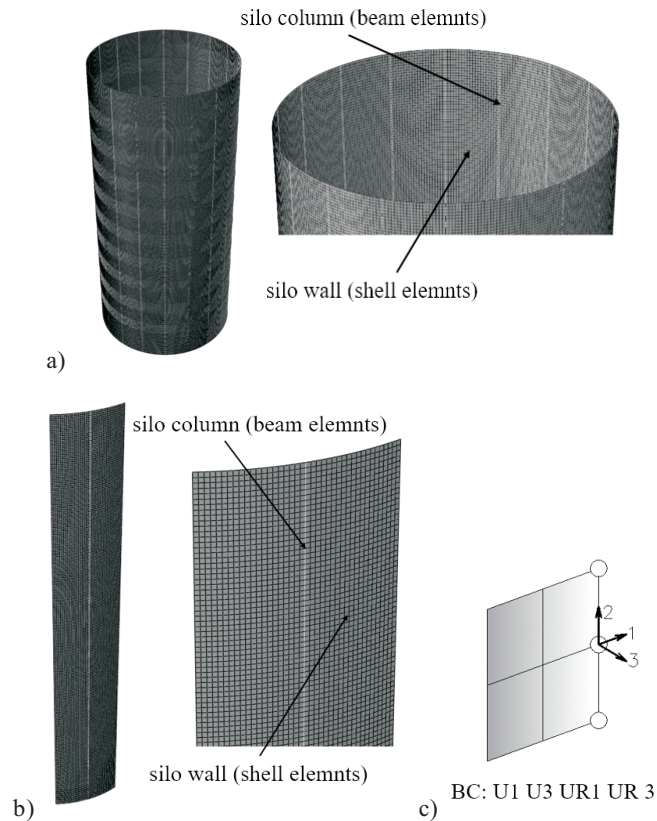

**Figure 4** FE mesh for the silo model with wall as equivalent orthotropic shell and columns modeled with 2-node beam elements: a) whole silo model, b) simplified silo model and c) boundary conditions (BC) for the side edges of the part of the silo model (restrained displacement directions)

The steel was assumed to be elastic (linear buckling analysis) with the following properties: modulus of elasticity  $E = 210$  GPa, Poisson's ratio  $\nu = 0.3$ . In the present analysis such as in Eurocode 3 [9] normal wall pressure is neglected. The horizontal wall loads would be transferred to the silo corrugated curved sheets and result in circumferential tensile forces.

The investigation was focused on the research of the model of a part of the silo that would have similar buckling load as the whole structure within a range of sparsely distributed columns. A section of cylinder with a single column was analyzed (Fig. 4b). The silos walls were modeled as equivalent orthotropic shell and the silo columns were modeled with 2-node beam elements (B33). The element size in the model of the part of the silo was similar to above described model of the whole structure. The total number of finite elements in simplified model of the silo with eighteen columns was 15'372 (about 6 times less than for the whole silo with walls modeled by equivalent orthotropic shell and columns modeled with beam elements).

Than a single silo column resting on elastic foundation provided by the silo walls according to Eurocode 3 [9] formula and to the proposed stiffness [11] for different distance of columns for 1D beam model of column were performed.

### 3. Eurocode approach and the proposed modification

According to Eurocode 3 (2009), there are two methods for calculating the stability of a cylindrical silo with vertical columns. The applicability of these methods is dependent on the spacing of the columns  $d_s$ . The first method named in this paper as the method "A" is based on an orthotropic shell theory. It is used for spacing column  $d_s < d_{s,max}$ , according Eqs (3) and (4) with satisfying results in comparison with 3D FEM analysis [8, 10]. The second method named in this article as method "B" is based on the solution beams on elastic foundations (Fig. 5). For the case of the column distance ( $d_s > d_{s,max}$ ). The characteristic buckling load bearing capacity  $N$  of single vertical column in a metal silo with corrugated walls is given by the following formula in Eurocode 3 [9]

$$N = 2\sqrt{EJ \times K} \quad (1)$$

with

$$K = k_s \frac{D}{d_s^3} \text{ and } D = 0.13Etd^3 \quad (2)$$

where  $EJ$  is the bending stiffness of columns in the plane perpendicular to the wall, the foundation stiffness  $K$  denotes the bending stiffness of corrugated sheets between vertical columns,  $k_s = 6$  is the coefficient,  $D$  denotes the wall sheet bending stiffness,  $E$  is the modulus of elasticity,  $t$  denote the sheet thickness and  $d$  is the sheet height. The following assumptions were met to lay down Eqs (1) and (2): the number of buckling half-waves along the circumference is equal to the half of the columns number, the column is loaded by vertical forces prescribed at both ends only (horizontal pressure is not considered). However, in the Eq. (2) the silo wall curvature is not taken into account.

For the small column distance  $d_s < d_{s,max}$ , where [10]

$$d_{s,max} = k_{dx} \left( \frac{r^2 D_y}{C_y} \right)^{0,25}, \quad (3)$$

there exists the approach in Eurocode 3 [9] for the silo buckling based on an orthotropic shell theory. The critical buckling resultant force  $n_{x,Rcr}$  per the unit circumference of an orthotropic shell should be evaluated at each appropriate silo level by minimizing Eq. (4) with respect to the critical circumference wave number  $j$  and the buckling height  $l_i$  as

$$n_{x,Rcr} = \min \left( \frac{1}{j^2 \omega^2} \left( A_1 + \frac{A_2}{A_3} \right) \right), \quad (4)$$

where:  $D_y$  – the flexural rigidity parallel to the corrugation,  $C_y$  – the stretching stiffness parallel to the corrugation and  $r$  – the cylinder radius and  $k_{dx}$  – the coefficient recommended to be taken as 7.4,  $j$  – the circumference wave number,

$\omega$  – the parameter including buckling height  $l_i$  and  $A_{1,2,3}$  – the parameters including the flexural and stretching stiffness in orthogonal directions of the equivalent orthotropic shell.

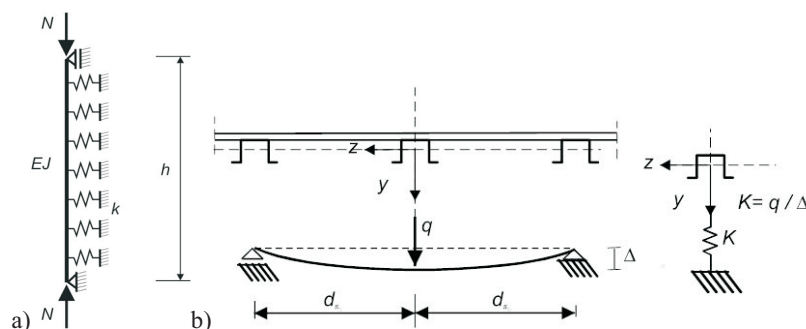

**Figure 5** Buckling of silo column (Eurocode 3 [9]) (a) vertical beam supported by elastic foundation and loaded by vertical forces at both ends, (b) stiffness determination of wall sheets during column buckling

The load bearing capacity  $N$  of a single vertical column in metal cylindrical silos should be apparently always smaller than the plastic force [9]

$$N_{b,Rk} = A_{eff} f_y, \quad (5)$$

where  $A_{eff}$  is the effective cross-sectional area of the column and  $f_y$  denotes the yield stress.

Due to the column distance in the silo of Fig. 1  $d_s = 1.4m > d_{s,max} = 1.16$  m, the appropriate standard formula for the silo buckling strength is described by Eqs (1) and (2). Using Eqs (1) and (2), the characteristic buckling strength was exceeded in 1 column profile twice for symmetric emptying and in 2 profiles about 2.5 times for non-symmetric emptying [8]. The column buckled for the characteristic wall shear stress equal to  $p_w = 10.67$  kPa (the limit load factor  $\lambda = 0.4$  according to Eqs (1) and (2)). In turn, the buckling strength calculated by Eqs. (3) and (4) was almost 7 times higher than this by Eqs. (1) and (2). This discontinuity of the Eurocode 3 [9] buckling capacity in function of the number of silo columns was described in [8, 10] (Fig. 6). As the method "A" gives satisfying results in comparison with 3D FEM analysis [8, 10] the discontinuity of relation between the silo buckling capacity and the number of columns (Fig. 7) may be caused by inaccuracy of the method "B".

In method "B" the circumferential wall curvature in the bending stiffness of corrugated sheets was not included (Fig. 5b). Modification of the stiffness determination of the wall sheets during column buckling was determined in [11] with the static scheme assumed in Fig. 6. In the proposed formula [11] the circumferential wall curvature, and a component associated with compression was included.

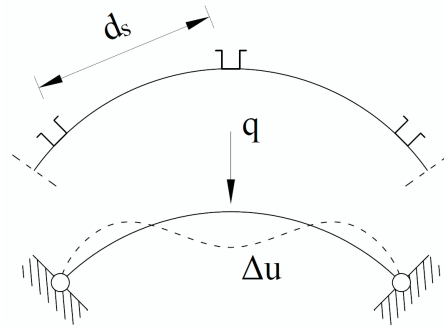

**Figure 6** Static scheme for modification of stiffness determination of wall sheets during column buckling

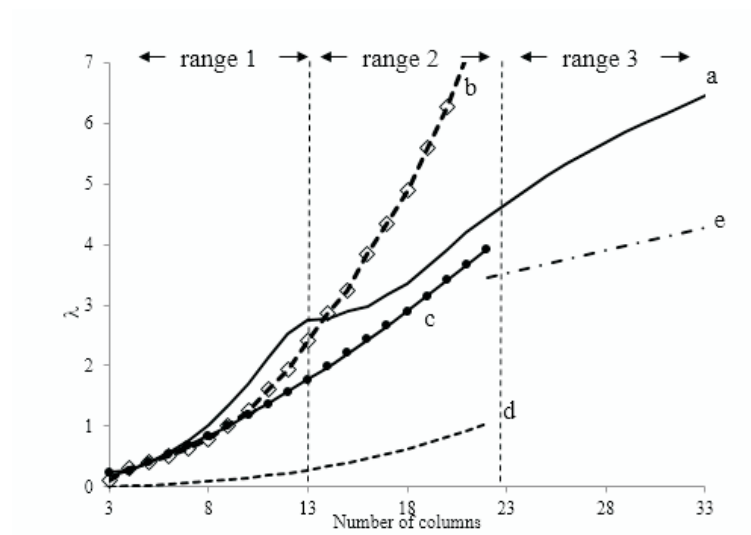

**Figure 7** Buckling load factor of silo versus number of vertical columns for the silo walls modeled with equivalent orthotropic shell and columns modeled with beam elements: a) whole silo, b) a part of the silo (Fig. 4b), and according to Eurocode 3 [9]: c) method "B" with proposed K [11], d) method "B" e) method "A"

#### 4. Silo buckling capacity

The computed buckling load factor (LBA) for a variable number of columns around the perimeter of the silo for the whole silo model (Fig. 4a) and for a section of the silo with a single column (Fig. 4b) by taking into account only a shear stress in the wall are presented in Fig. 7. Results of numerical analysis were compared with the procedures according to Eurocode 3 [9] for variable number of columns around



the perimeter (method "A" and "B") and to buckling load factor for single column resting on elastic foundation according to the proposed in [11] formula for elastic stiffness. The calculated first buckling eigen-modes are given in Figs. 8–9.

#### 4.1. Calculation of whole silo model

The buckling load factor for the silo with a variable number of columns increased with the number of column (Fig. 7). The number of circumferential half-waves was depended on the number of columns (Fig. 8a). Based on the linear buckling analysis, three ranges of the column spacing were determined, which corresponded to three different buckling forms (Fig. 7). In the first range of the column spacing (Fig. 8) the silo buckling mode had three half-waves for every two sections between the silo columns in circumferential direction, so every second column was subjected to flexural buckling. Other columns were twisted. The buckling mode of the silo in the first range of the column spacing corresponded to the arc deformation with boundary conditions according to the model form Fig.6. Buckling mode within the second range (12 to 22 columns around the circumference, or the column spacing between 1.15 to 2.1 m) was characterized by buckling of all columns on the perimeter. The number of circumferential half-waves correspond to the number columns (silo columns buckled inward or outward) (Fig. 8). Buckling form in the third range was appropriate for buckling of orthotropic shell. On one of circumferential half-wave there were more than one silo columns so the number of circumferential half-waves was not depended from the number of silo columns. Calculated columns spacing  $d_{s,max}$  (between the range 2 and 3) was compatible to described by Eurocode 3 [9]. However, the definition of the border between ranges 1 and 2 has not been determined in Eurocode 3 approach. The number of half-waves along the silo height was equal three in all of the analyses cases of the silo column spacing.

#### 4.2. Calculation of simplified silo model

The buckling load factor LBA for the simplified silo model with different distance of columns was consistent with the result of the whole structure only in the first range of the column number (from 0 to 12 columns) or for a sparse column spacing (Fig. 7). Buckling mode of the simplified model was constant and independent of the column spacing (Fig. 9). At a certain spacing of columns the results of the analyzed models differ significantly and moreover, the results of the simplified model gave overestimated buckling resistance of the silo (in range 2).

The buckling resistance of the simplified silo model as compared to the Eurocode 3 [9] approach (Fig. 7) were about 9 times higher. Application of the proposed in [11] stiffness of the column elastic foundation to the Eurocode 3 [9] formula (Eq. (1)) was closer to FEM analysis than the formula currently recommended in code. Additionally solution gave safe estimation of the silo buckling capacity.

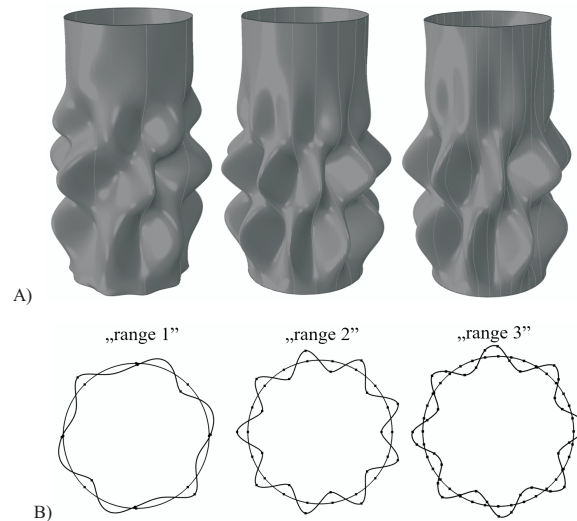

**Figure 8** Buckling modes of the whole silo model: A) silo 3D view and B) horizontal cross section of the silo

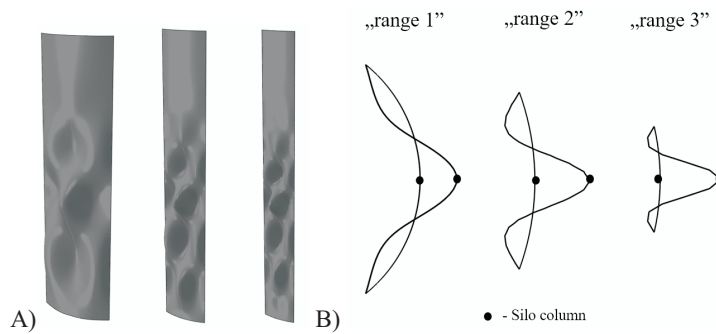

**Figure 9** Buckling modes of simplified silo model: A) view and B) horizontal cross section

## 5. Conclusions

Some conclusions can be drawn from our stability FE studies for a different models of the silos made from corrugated curved sheets strengthened by vertical columns:

- The silo design according to the orthotropic shell theory in Eurocode [9] is more realistic (Eqs (3) and (4)) than the design based on the method considering the column resting on the elastic foundation (Eqs (1) and (2)). The Eqs. (1) and (2) are largely too conservative as compared to the FE results.
- The proposed modification of the column elastic foundation stiffness gave results comparable to the FE numerical analysis (differences about 20%) and safe estimation of the silo buckling capacity.

- The proposed simplified model consisting of a part of the silo wall was comparable with the whole silo FEM analysis only in the range "1" of the column distance.
- Eurocode 3 method 'A' based on the orthotropic shell was about 30% lower than the results obtained by whole silos FEM analyses.
- The limit of the applicability of the simplified model should be determined (between range "1" and "2").

Our studied will be continued in order to verify the proposed methods for the calculation buckling strength of silo with different geometry.

In our future research a simplified silo model within range "2" and the influence of the horizontal pressure will also be investigated and the local buckling of the columns will be taken into account.

#### Acknowledgements

The financial support of the Polish National Research Centre NCN in the frame of the Grant No 2011/01/B/ST8/07492 "Safety and optimization of cylindrical metal silos containing bulk solids with respect to global stability" and of the Polish National Centre for Research and Development NCBR in the frame of the Grant POIG.01.03.01-00-099/12 "Innovative method of dimensioning and construction of large industrial silos made from corrugated sheets" is gratefully acknowledged. The numerical calculations were performed using the computing resources of CI TASK at Gdask University of Technology.

#### References

- [1] **Teng, J. G. and Rotter, J. M.:** Buckling of Thin Metal Shells, *Taylor & Francis*, London, **2004**.
- [2] **Singer, J., Baruch, M. and Harari, O.:** On the stability of eccentrically stiffened cylindrical shells under axial compression. *Int. J. Solids Struct.*, 3, 445–470, **1967**.
- [3] **Singer, J., Arbocz, J. and Babcock, C. A.:** Buckling of imperfect stiffened cylindrical shells under axial compression, *AIAA J.*, 9 (1), 68–75, **1971**.
- [4] **Nemeth, M. P.:** Buckling analysis for stiffened anisotropic circular cylinders based on Sanders nonlinear shell theory, *NASA Technical Report*, TM-2014-218176, **2014**.
- [5] **Wójcik, M., Iwicki, P. and Tejchman, J.:** 3D buckling analysis of a cylindrical metal bin composed of corrugated sheets strengthened by vertical stiffeners, *Thin-Walled Structures*, 49, 947–963, **2011**.
- [6] **Iwicki, P., Wójcik, M. and Tejchman, J.:** Failure of cylindrical steel silos composed of corrugated sheets and columns and repair methods using a sensitivity analysis, *Eng. Fail. Anal.*, 18, 2064–2083, **2011**.
- [7] **Rotter, J. M. and Sadowski, A. J.:** Cylindrical shell bending theory for orthotropic shells under general axisymmetric pressure distributions, *Eng. Struct.*, **42**, 258–265, **2012**.
- [8] **Iwicki, P., Rejowski, K. and Tejchman, J.:** 2015. Stability of cylindrical steel silos composed of corrugated sheets and columns based on FE analyses versus Eurocode 3 approach, *Eng. Fail. Anal.*, 57, 444–469, **2015**.
- [9] EN1993-4-1, Eurocode 3: Design of Steel Structures, Part 4-1: Silos, Tanks and Pipelines Silos, *CEN*, Brussels, **2009**.



- [10] **Sondej, M., Iwicki, P., Tejchman, J. and Wójcik, M.:** Critical assessment of Eurocode approach to stability of metal cylindrical silos with corrugated walls and vertical stiffeners, *Thin-Walled Structures*, **95**, 335–346, **2015**.
- [11] **Rejowski, K. and Iwicki, P.:** Simplified stability analysis of steel cylindrical silos with corrugated walls and vertical columns, *XIII International Conference on Metal Structures*, Zielona Góra (In press), **2016**.
- [12] EN1991-1-4, Eurocode 1: Basis of Design and Action on Structures, Part 4: Actions in Silos and Tanks, *CEN*, Brussels, **2008**.
- [13] **Rejowski, K. and Iwicki, P.:** Buckling analysis of cold formed silo column, *Stability of Structures XIV th Symposium*, Zakopane, 97–98, **2015**.
- [14] ABAQUS, Theory Manual, Version 6.8, *Hibbit, Karlsson & Sorensen Inc.*, **2008**.

