

CHIP SUCTION SYSTEM IN CIRCULAR SAWING MACHINE: EMPIRICAL RESEARCH AND COMPUTATIONAL FLUID DYNAMICS NUMERICAL SIMULATIONS

Jacek Baranski – Przemyslaw Dudek

ABSTRACT

The experimental analysis of the wood chip removing system during its redesigning in the existing sliding table circular saw and computational fluid dynamic (CFD) numerical simulations of the air flow process is presented in the paper. The attention was focused on the extraction hood and the bottom shelter of the actual existing system. The main aim was to perform experimental research on the pressure distribution inside the hood and at the exit of the bottom shelter and the air flow distribution during operation of wood chip removal system. In the work a systematic experimental study of pressure and numerical modelling of the air flow distribution in the upper cover and bottom shelter during operation for the selected rotational speed of saw blade of 3 500 and 6 000 min^{-1} with a diameter of \varnothing 300 mm and \varnothing 450 mm were carried out. The analyses of results obtained from the experimental measurements and numerical simulations allowed the estimation of the areas with improper air flow hindering the controlled transport of wood chips and to optimize the shape of extraction hood and the bottom shelter. As the result, a new design of the chip suction system was obtained, noticeably improving the chips extraction from the tool operation space.

Key words: sliding table saw circular sawing machine, chip removing system, experimental study, numerical simulations.

INTRODUCTION

Nowadays, the recent development of woodworking machines design, introduction of new technologies and also the material machining and feed speeds result in the need to provide more efficient systems of wood particles (e.g. chips, dust) removing. The manufacturers of woodworking machines quite freely approach to the problem of chip removing from the workspaces of their machines. Ideas used in some devices for shapes and dimensions of the suction system elements, linking these suctions to common, interior collectors, separators, moving suctions, etc. do not always work well in reality (BARAŃSKI *et al.* 2016). It is possible to give examples of machines manufactured by well-known and less-known companies, whose suction arrangements are ineffective during standard operation. In operation manuals there are often presented the essential parameters of the extraction installation for given woodworking machine, e.g. the necessary air velocity, its amount and the value of vacuum pressure. However in the area around the operating tool even higher vacuum pressure is required. A modern sliding table saw operating with

improper designed extraction installation, loses its performance and service life immediately (BARAŃSKI and PIKAŁA 2017, BARAŃSKI *et al.* 2018, ORŁOWSKI *et al.* 2020).

In the all technological processes of machine wood chips and dust, besides the main product, a by-product is also generated. These by-product are called chips Their shape, size and amount mainly depend on the form, physical and mechanical properties of sawed wood as well as on the shape, dimensions, type of machine, sharpness of the cutting tool, and technical and technological conditions of sawing process (BELJO LUČIĆ *et al.* 2005, OČKAJOVÁ *et al.* 2006, KOPECKÝ and ROUSEK 2007, KLEMENT and Detvaj 2007, OČKAJOVÁ *et al.* 2016, KMINIAK *et al.* 2020, ROGOZINSKI *et al.* 2020).

On the other hand, the space around the rotating tool is usually surrounded by different shape and dimension upper hood, connected with an exhaust fan using partially flexible pipes. Thus, the shape and dimensions of chip removing system are especially designed and made for specific woodworking machine requirements.

The machine operation parameters together with material properties with its drying process type strongly determine the particle size distribution of chipped wood (BARAŃSKI *et al.* 2016, ORŁOWSKI *et al.* 2019).

Particles of wood substance formed in individual chipping and machining processes are called “bulk wood substance” (DZURENDA 2007). In this reason, wood industry workers are exposed to airborne wood dust particles in the surrounding air of the workplace and may cause different occupational health problems (KOHLENER 1995). Currently, the nature of the present production and chips features require their continuous removal from the place where they are generated. As far as sanding dust is concerned, it is removed by means of an air-technical device – suction installation. To develop such suitable suction system, it is important to know the size and shape of bulk particles, which are the basic data for characterizing the bulk substance. The above characteristics affect physical and mechanical properties of bulk substance (bulk density and angle, tilt angle, aerodynamic properties of particles in the pipes of the suction system) and properties of separation or filtration in the separating device (DZURENDA 2007, KOHLER 1995). Likewise, those characteristics affect the service life of equipment in the workplace, where chips are generated and transported and filtering elements and last but not least the safety of the working environment.

Removal of dust is very difficult when working space is large and when the tool moves during processing at relatively high velocity. Depending on the woodworking machine type and the shape and size of its dust area, serious problems may occur concerning the effective dust remove through a suction system during certain machining processes. The chips' dispersion in different directions in the space of the treatment zone is very unfavorable in this respect. When movement direction of the created chips during machining does not coincide with that of the air flow forced by an extraction system, many chips are still not removed and can become dispersed in the environment around the machine and workers. This takes place during sawing when the whole tool goes into the material piece. For this reason there are many problems with the direct chips discharge from the working space and operating tools. Also the chips dispersion in all directions occurs due to rotational speed of those tools. Many researchers investigated the possibility of reducing the particle (airborne) by the control of machining parameters and by varying the cutting and feed speed respectively, tool type and its size, cutting angles, number of blades and processed material respectively (FUJIMOTO and TAKANO 2003, HEMMILÄ *et al.* 2003, FUJIMOTO *et al.* 2011, PAŁUBICKI and ROGOZIŃSKI 2016, HLÁSKOVÁ *et al.* 2015). According to those results, the average chip thickness is one of the most important parameters of wood machining. Furthermore, sanding process as the major source of airborne dust generation was investigated by OČKAJOVÁ and BELJAKOVÁ (2004), KUČERKA and OČKAJOVÁ (2018).

Wood processing companies, as sources of air pollution, emit into the air wood dust

classified as solid pollutants. Clean Air for Europe is the initiative taken by the EU Commission, by which one of its main aims set in 2002 was: "... To reach such a quality of the environment where the level of pollutants coming from human activities doesn't cause any significant impacts and risks for human health ..." (EU Decision 2002).

In the paper, the results of the systematic empirical research together with numerical simulations of air flow distribution process of the chip removing system in existing sliding table circular sawing machine which were carried out are presented. The aim of the full research was to optimize and redesign the chip extracting system of the device. The special attention was focused on upper hood and bottom shelter conditions respectively.

MATERIALS AND METHODS

Experiments

During the experimental research, pressure distribution inside the upper hood and velocity measurement at its exit were accurately recorded with the selected rotational speeds of 3 500 min^{-1} and 6 000 min^{-1} of saw blade with the diameter of \varnothing 300 mm and \varnothing 450 mm respectively (BARAŃSKI *et al.* 2016, BARAŃSKI *et al.* 2018). Simultaneously to the experimental research, the numerical simulations for selected boundary conditions and rotational speeds with chosen saw diameter blades were performed. The analysis of the results of these experiments and numerical modelling helped to identify in the upper cover areas with insufficient vacuum value (and even with small overpressure), which caused chip ejection from the upper hood and decrease operating volume of bottom shelter. On the basis of the obtained results, a new design of the hood and bottom shelter shapes has been proposed.

The pressure and velocity measurements were performed using the wide and narrow upper hood and the bottom shelter of the suction system with different diameter and rotational speed of the saw blades respectively. For the saw blade No. 1 two of its extreme rotational speeds 3 500 min^{-1} and 6 000 min^{-1} , and for saw blade No. 2 its nominal rotational speed 3 500 min^{-1} were considered respectively. Table 1 shows the parameters of the saw blades used during experiments.

Tab. 1 The main parameters of the sliding table saw blades during experiments.

	Circular saw 1		Circular saw 2
Tool diameter, D (mm)	\varnothing 300		\varnothing 450
Number of teeth, z	96		72
High of tooth high, h (mm)	9.82		19.63
Overall set (kerf width), S , (mm)	3.2		4.4
Thickness of saw blade, a (mm)	2.2		3.2
Rotational speed, n (min^{-1})	3 500	6 000	3 500

The relative pressure was measured using the digital multi-function measuring instrument TESTO 480 (TESTO SE & Co., Germany). The results were averaged for 10 seconds at each point. Measuring range was from -10 to +10 kPa, resolution 0.01 kPa and accuracy ± 0.3 Pa +1% of measured value in the lower range. Velocities at the exit of the hood as well as from bottom shelter were measured using the same device equipped with a hot wire probe. Measuring range was 0–20 m/s with resolution 0.01 m/s and accuracy was ± 0.03 m/s + 5% of measured value.

The base case of the wide upper hood inner dimensions are length 710 mm, high 240 mm and width 144 mm respectively and the base case of the narrow hood inner dimensions are length 710 mm, high 157 mm and width 50 mm respectively, Fig. 1. The

distance between the saw blade and the inside the cover is 245 mm and 165 mm for saw blade \varnothing 300 mm and \varnothing 450 mm respectively.

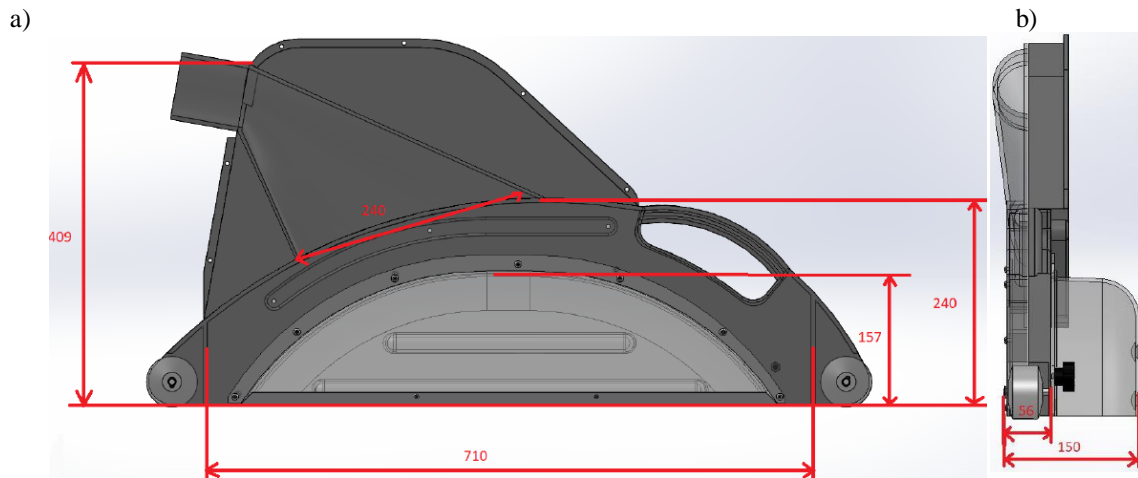

Fig. 1 The view of the base case upper hood shape with all dimensions: a) side view, b) front view.

The empirical research consisted of measuring the relative pressure distribution zero-referenced against ambient air pressure at several points on the wide and narrow upper hood of suction-chip removing system (points “A”-“I” on the upper part and “a”-“i” on the side part of the wide hood and points “b*”-“h*” on the side of narrow hood). Locations of all measuring points are shown in Fig. 2 and Fig. 3.

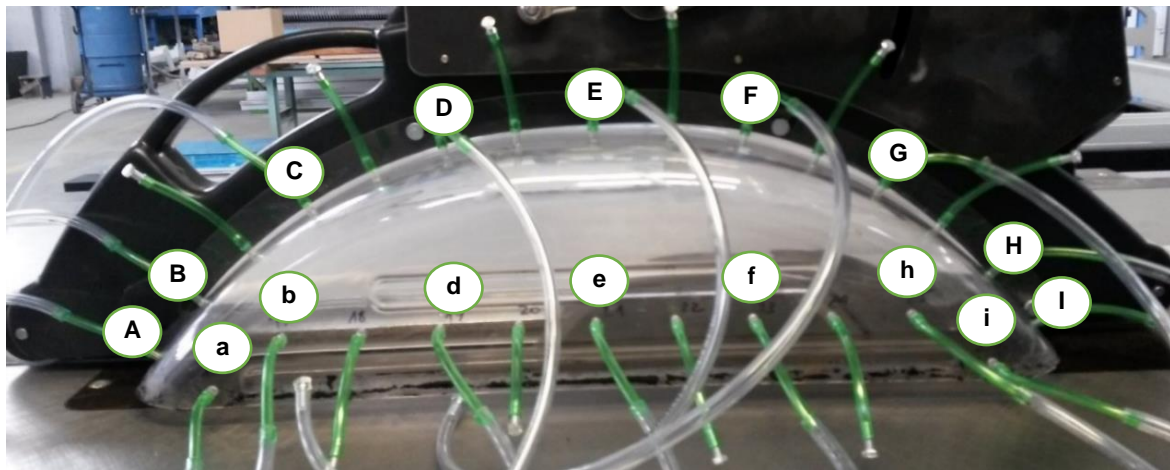

Fig. 2 The view of measurement points on a wide cover location.

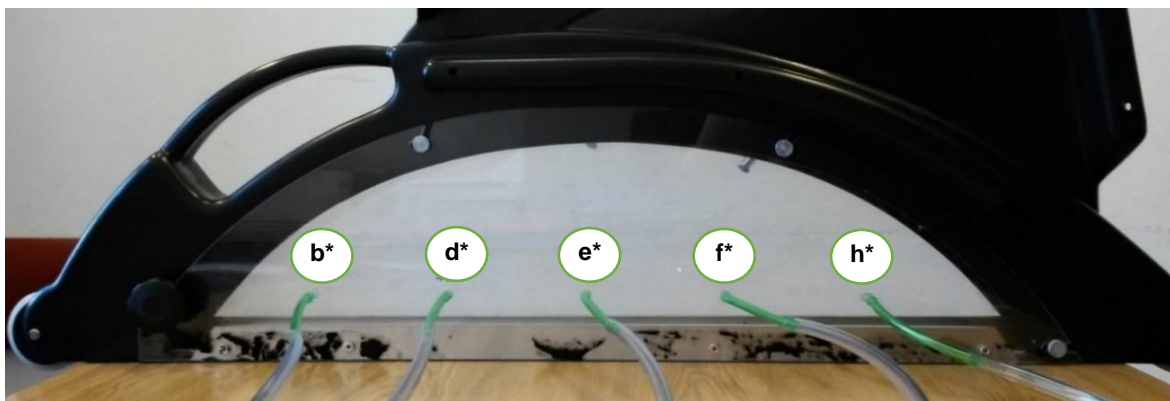

Fig. 3 The view of measurement points on a narrow cover location.

The obtained results from measurements were analyzed and verified experimentally using different shape design of the upper hood, Fig. 4.

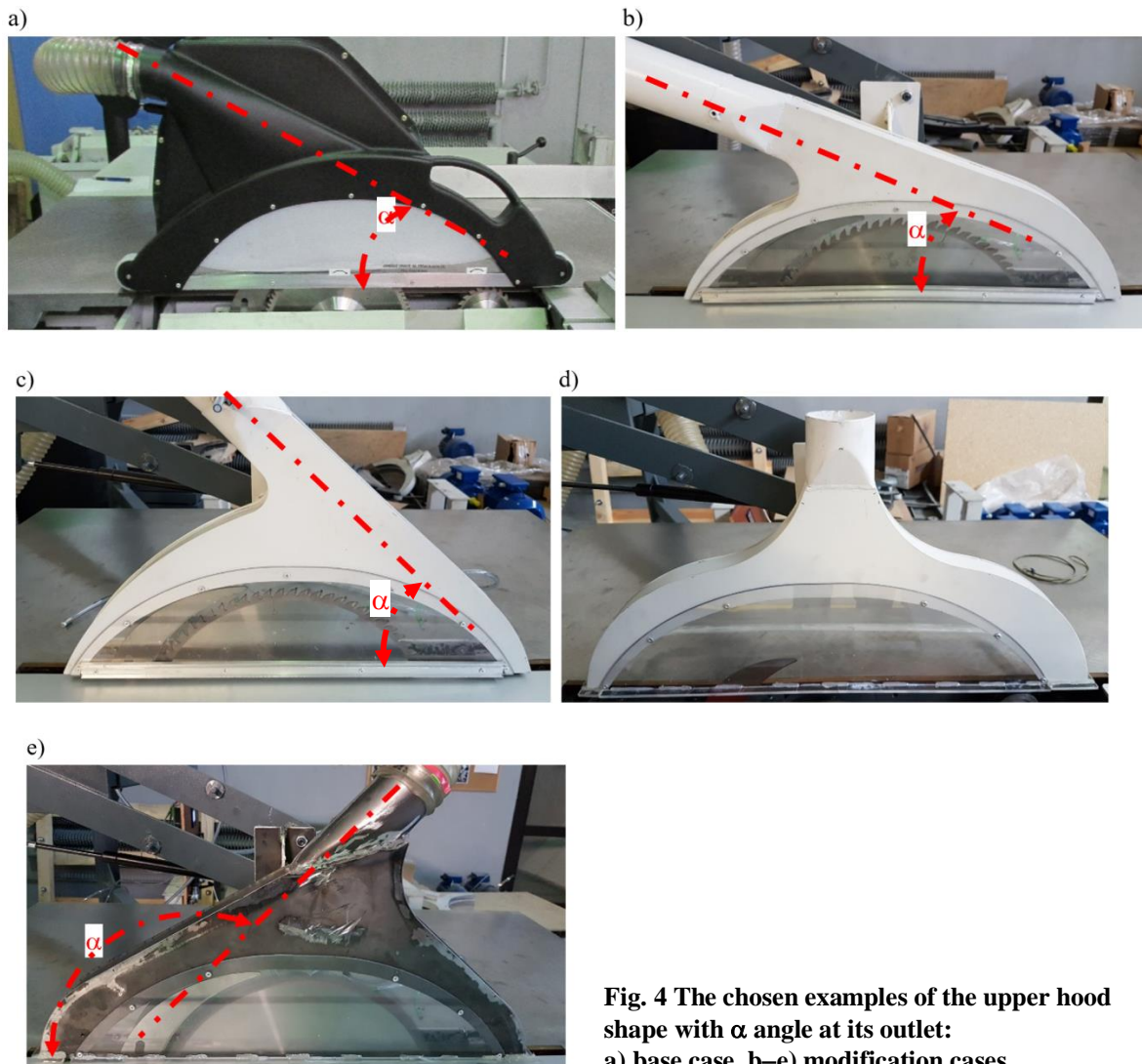

Fig. 4 The chosen examples of the upper hood shape with α angle at its outlet:
a) base case, b–e) modification cases.

The bottom shelter shape was modified to minimize its operating volume and leakages and the outlet channel shape in the upper part was changed.

Numerical simulations

To create 2D numerical models of the sliding table sawing machine complex geometry 3D model of the device was created in CFD ANSYS Software. CFD Fluent, which is a steady state/transient, finite volume program that can solve three-dimensional fields of pressure, velocity, temperature, kinetic energy of turbulence and dissipation rate of turbulence belongs to this group. The code operates by solving the governing differential equations of the flow physics by numerical means on a computational mesh and is able to predict air velocity.

In the second step the 2D models were created taking into account simplifications of 3D model with necessary boundary conditions and circular saw blade and scoring blade properties respectively (Fig. 5). The 2D numerical model consists of an unstructured mesh. Thus, it was possible to divide the flow region into finite elements of small size. This approach was very important to achieve convergence and accuracy of the solution. For grid generation, the unstructured finite volume grid was used to divide the very complicated

geometry of the flow domain into discrete segments with high grid quality. This approach is very important to get a convergent and accurate solution. The number of unstructured elements (cells) was about 1 892 600. Combining the body-fitted meshing capabilities with unstructured non-orthogonal grids and arbitrary coupling between mesh blocks gives great flexibility in the representing highly complex geometries.

The finite volume method and first-order upwind scheme were used to convert elliptical partial differential equations into algebraic equations, which are solved using the iteration method.

The standard Simple scheme was used for pressure-velocity coupling, while the under-relaxation method was used to control the update of computed variables during the iteration process.

For the turbulent flow modelling the standard model of turbulence k- ϵ (k- ϵ standard) and a mesh of the entire dust extraction system with machining material and with or without a separating knife were used.

The numerical modeling simulations for each case were performed until the values of the solution results of the equations' behavior (the so called residuals) were stabilized in the narrow range of the variation at the level of 10^{-4} .

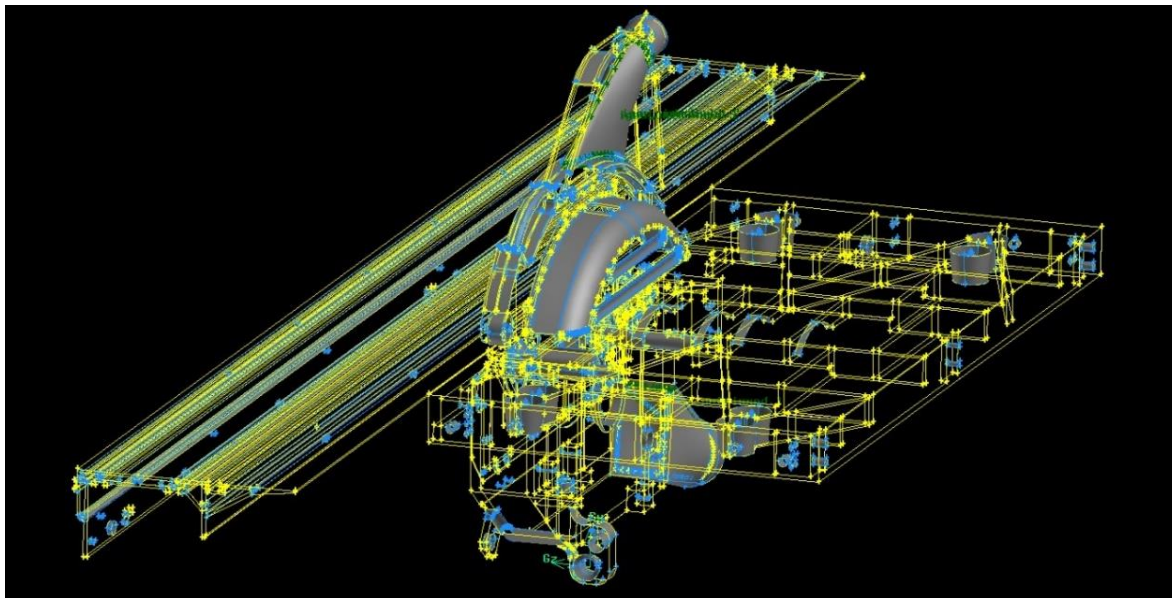
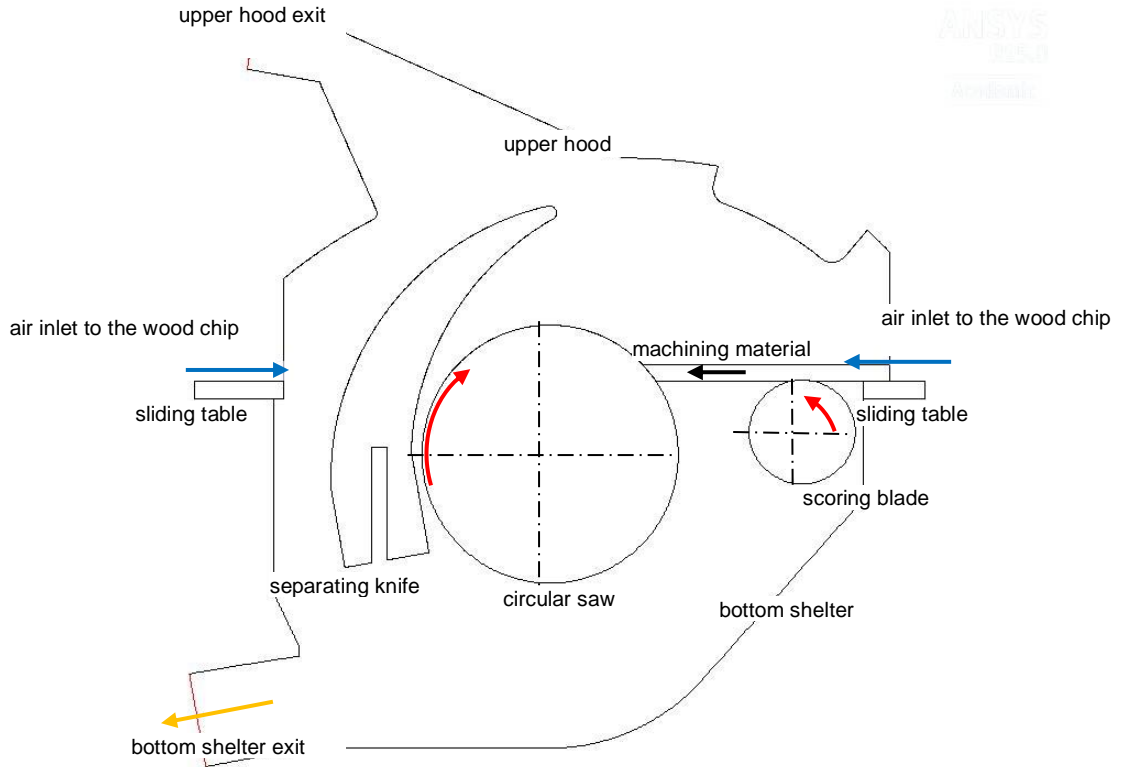

Fig. 5 The view of the sliding table saw 3D numerical model.

In the selected cases, the air flow in the dust extraction system was analyzed without taking into account the occurrence of the wood chips movement. In Fig. 6 the examples of the circular sawing machine numerical models with the diameter \varnothing 300 mm and \varnothing 450 mm circular saw blades respectively and separation knife are presented.

The vacuum pressure values at the outlets from the upper hood and bottom shelter were assumed on the basis of the results from the experimental measurements and set 200 Pa at the upper hood exit and 400 Pa at the lower shelter exit respectively. The maximum value of the vacuum pressure at both outlets, e.g. 1 500 Pa, was adopted in accordance with the information provided by the panel saw Manufacturer (REMA S.A., Reszel, Poland) and the data available in literature (DZURENDA 2007). Simulations of air flow process for vacuum pressure at both exits with values of 200 Pa and 400 Pa respectively were also performed.

a)



b)

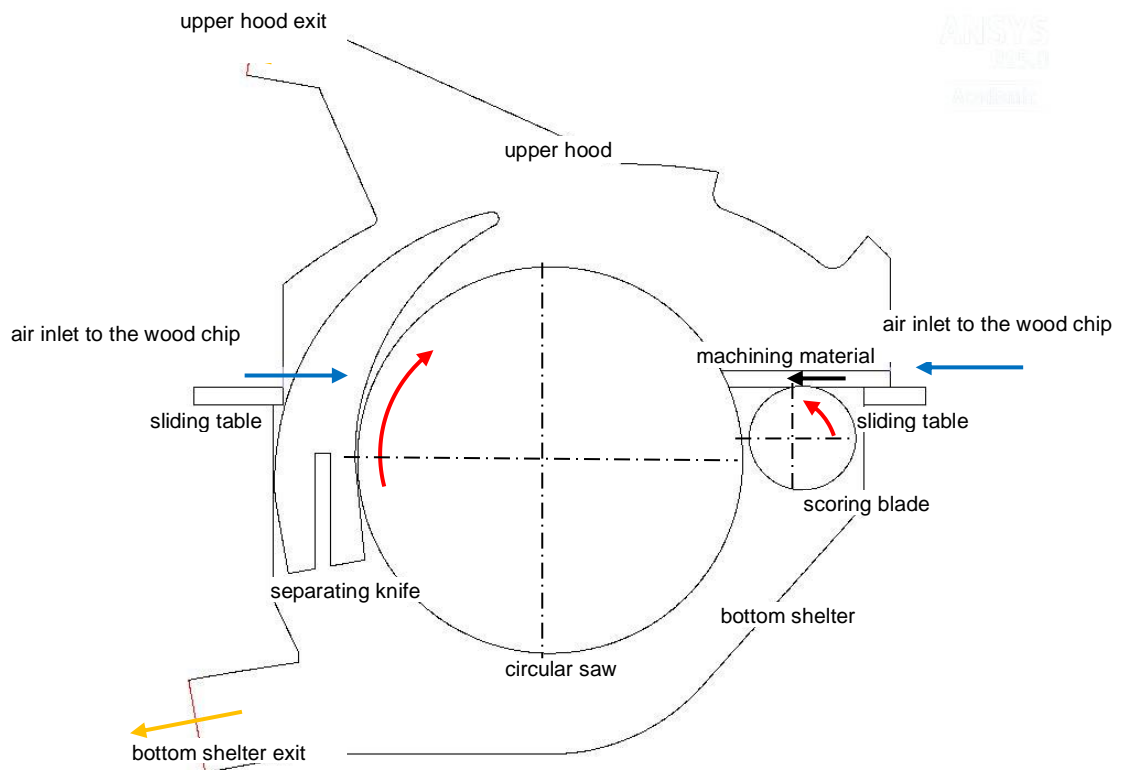

Fig. 6 The cross section view of the sliding table circular sawing machine numerical model with boundary conditions: a) saw diameter blade \varnothing 300 mm, b) saw diameter blade \varnothing 450 mm.

The numerical simulations were performed in the case of different boundary conditions and circular saw blade diameter, as shown in Table 2.

Tab. 2 The boundary conditions assumed for numerical simulations for the sliding table circular sawing machine with the chip removing system.

	Ambient pressure	Vacuum pressure at bottom shelter exit	Vacuum pressure at upper hood exit	Circular saw rotational speed	Scoring blade Rotational speed
	[Pa]	[Pa]	[Pa]	[min ⁻¹]	[min ⁻¹]
circular saw Ø 300 mm					
1.	101 130	- 400	- 200	3 500	8 500
2.	101 130	- 400	- 400	3 500	8 500
3.	101 130	- 1 500	- 1 500	3 500	8 500
4.	101 130	- 400	- 200	6 000	8 500
5.	101 130	- 400	- 400	6 000	8 500
6.	101 130	- 1 500	- 1 500	6 000	8 500
circular saw Ø 450 mm					
7.	101 130	- 400	- 200	3 500	8 500
8.	101 130	- 400	- 400	3 500	8 500
9.	101 130	- 1 500	- 1 500	3 500	8 500

For each modeling case, which was carried out, the chosen simulation results in the ANSYS Fluent software will be presented as velocity vector field in cross section of sliding table circular saw and chip removing system, the upper hood and bottom shelter.

RESULTS AND DISCUSSION

Numerical simulations

A series of computer simulations were performed. Each simulation was performed in the case of various boundary conditions. The differences concerned the rotational speed of the saw, the vacuum pressure at the both outlet and the diameter of the circular saw.

Figure 7 presents the results of numerical simulations of the air flow process through the sliding table circular saw without separating knife and with chip removing system and material machining for parameters, which were assumed in the numerical methodology. We can see the behavior of the air flow process, which after entering the dust removing system is directed to the outlets of lower shelter and upper hood.

On the other hand, Figure 8 shows the results of numerical modeling of the air flow process of the same device equipped with separation knife. It can be noticed that the occurrence of the knife affects the less favorable distribution of the air flow in the rear part of the dust extraction system. Additionally, in the front part of the upper hood, it can be seen that the air is pushed into the surrounding environment with greater intensity compared to the previous case (marked with the red circle). The velocity value is higher in Fig. 7. There is no air turbulence zone in the upper part of the upper hood, near to the handle (marked with the blue circle). This is the effect of the rotating saw marginal impact on the flowing medium. The separating knife is an obstacle in the air flow process at the exit of the lower shelter. It reduces the saw impact on the air flow. In the rear part of the upper hood, the inflowing air is separated into two streams and flows to the outlets of the lower shelter and the upper cover. In the upper hood the air is directed into the environment, toward its upper wall. In addition, there is an area where the air flow velocity values are small.

After many numerical simulations performed it can be concluded that there was the rotating circular saw large impact on the medium flow and intensive mixing process of the air with the air stream incoming from surrounding environment to the dust removing system.

This was due to the high value of the linear velocity of the circular saw and the shape of the upper hood, which had got the so called the dead space (recirculation zone) from which the air was unable to get out from the upper hood. In addition, it could clearly noticed the effect of the circular saw on pushing the air out the upper hood in its front part (Fig. 6b and 7b). This was the total effect of the linear velocity of the circular saw and the small vacuum pressure value occurrence (200 Pa) at the upper hood exit.

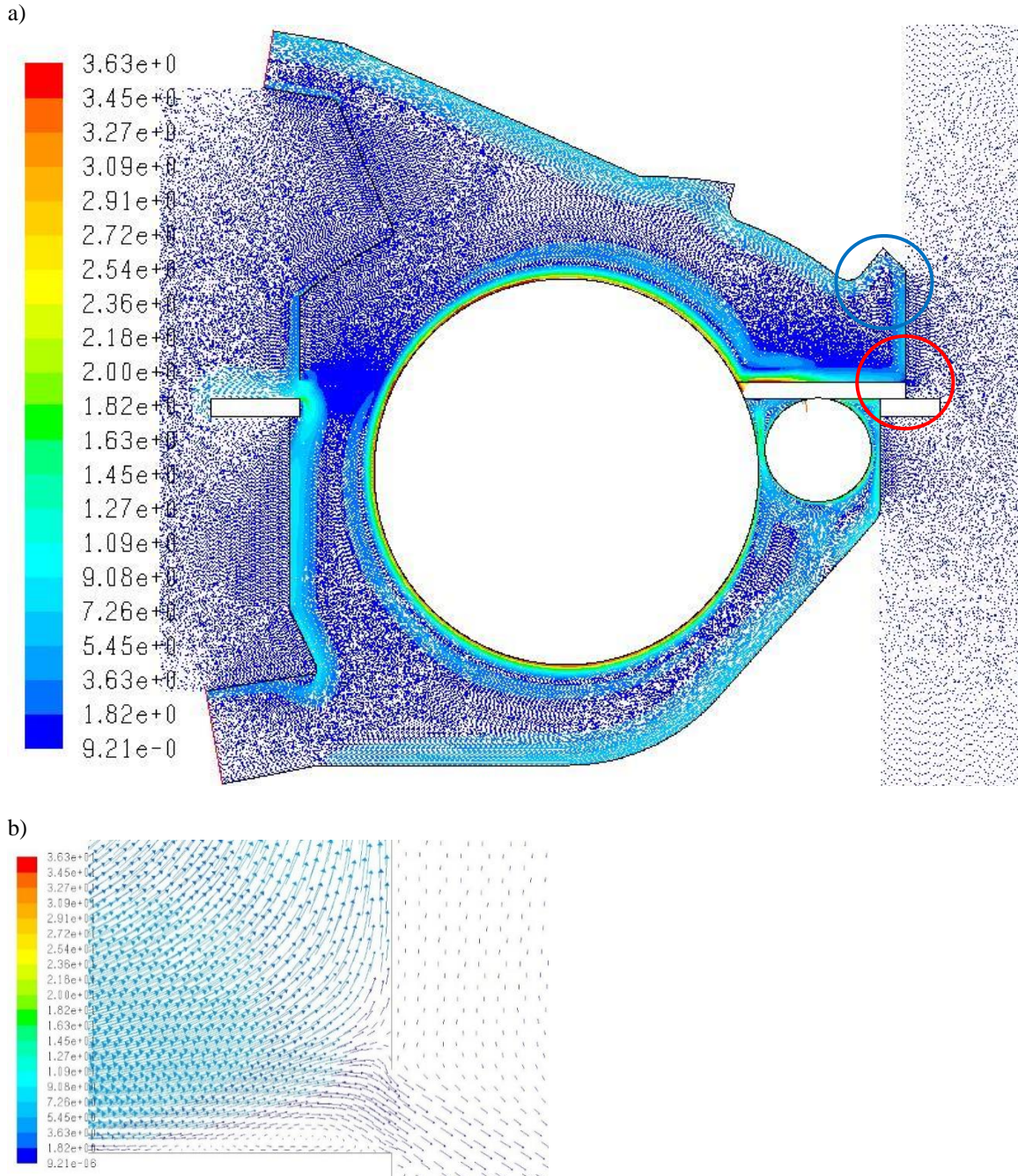

Fig. 7 Results of numerical modeling of: a) the air flow velocity field through the circular saw and chip removing system with saw diameter \varnothing 450 mm without separating knife, b) the view of the air flow in the front part of the upper hood.

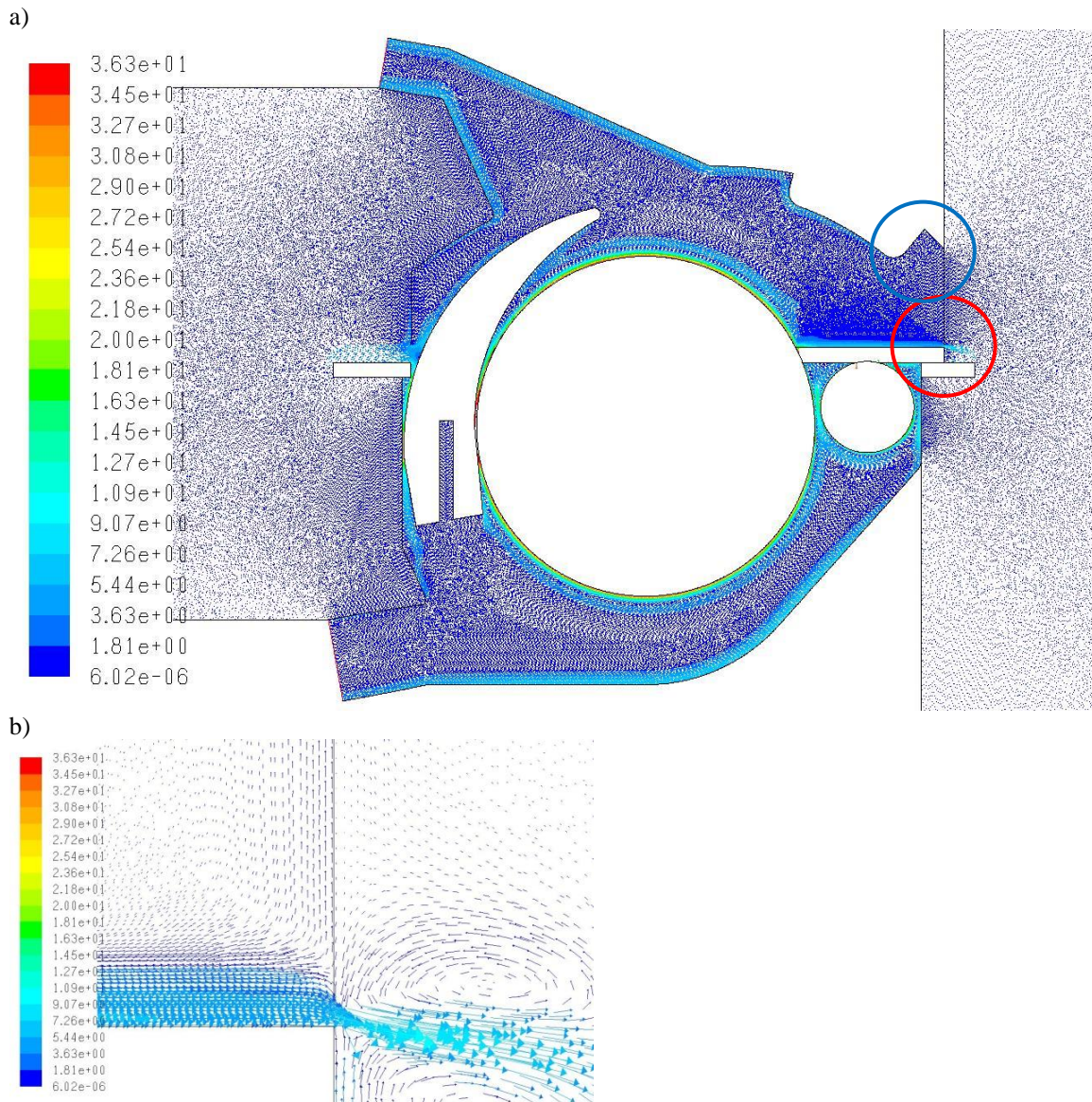

Fig. 8 Results of numerical modeling of: a) the air flow velocity field through the circular saw and chip removing system with saw diameter \varnothing 450 mm with separating knife, b) the view of the air flow in the front of the upper hood.

In Fig. 9 the chosen examples of the upper hood of the chip removing system shapes simulation results are presented. The each modification of the upper hood of chip removing system was experimentally examined during measuring the velocity in selected points and relative pressure values along the upper hood in different locations.

After numerical simulations and empirical research the final shape of the upper hood of dust removing system was obtained which characterized high efficiency in chip collection and removing from working area of rotating tools.

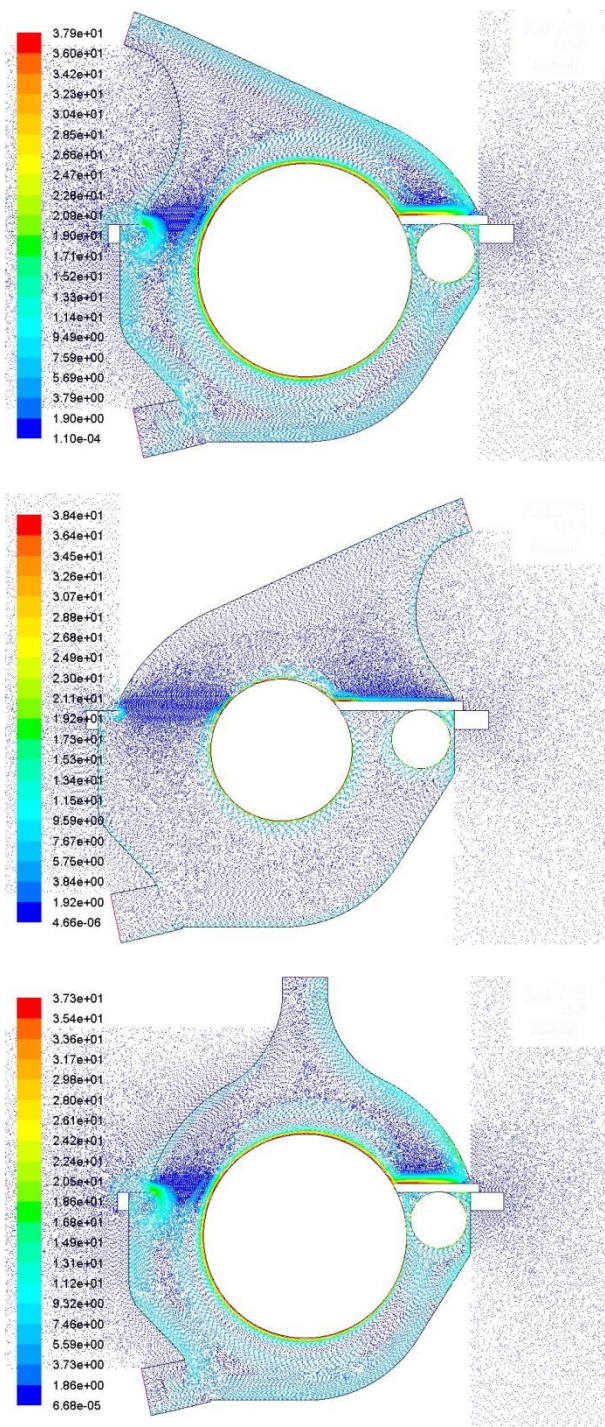

Fig. 9 The selected examples of the results of numerical modeling of the air flow through the circular saw and chip removing system of the different upper hood shapes.

The results of relative pressure measurements for the wide and the narrow hood of existing system, referred further as "base case", showed that at most of the measurement points there was a vacuum pressure existence, as it was expected. However, there were observed some places, with a very low vacuum pressure value or even gauge pressure. These are points "A"- "B" and "a"- "b" for wide and "b*"-"d*" for narrow hoods respectively. They are located in the zone where the highest influence of the air stream created by the teeth width and rotational speed of the saw blade exists. That influence at three of the critical points can be noticed in Fig. 10 and Fig. 11. Saw blade rotational speed (Fig. 10) adversely

affects the pressure distribution field, causing disappearance of desired vacuum pressure. The same result can be seen if saw blade diameter increased (Fig. 11). Contrary effect occurs in all critical points.

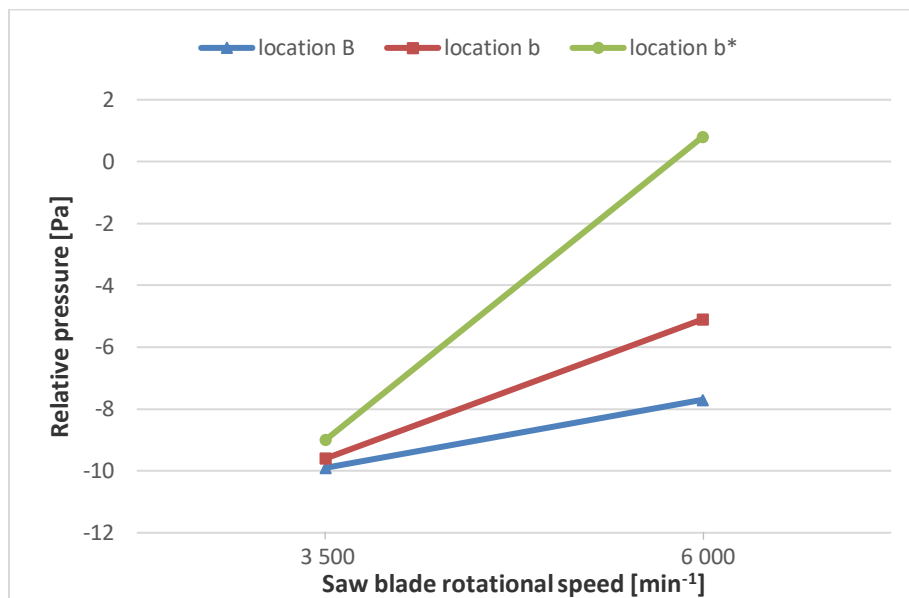

Fig. 10 Relative pressure [Pa] as a function of saw blade rotational speed at different location for wide and narrow cover; saw blade No. 1 (Ø 300 mm), fan motor frequency 50 Hz.

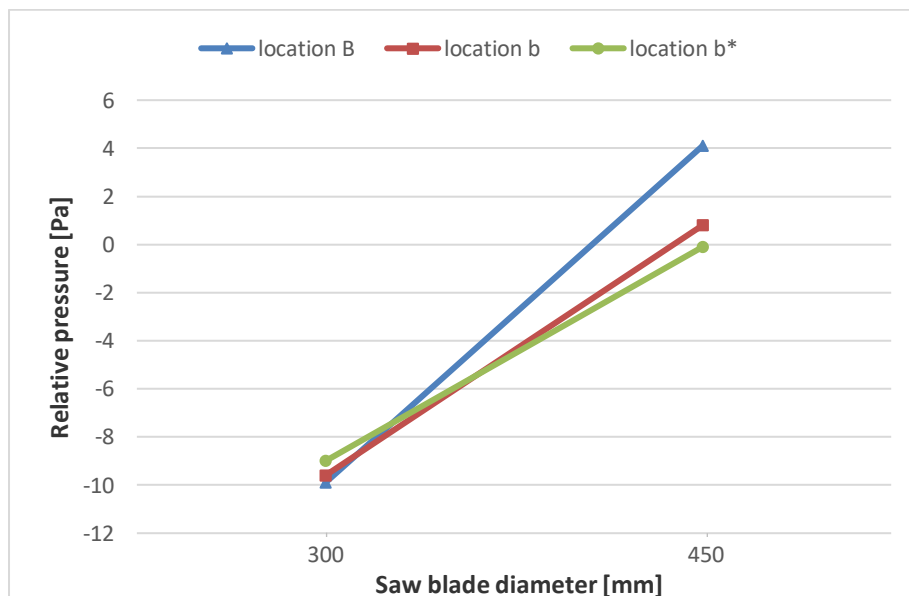

Fig. 11 Relative pressure [Pa] as a function of saw blade diameter at different location for wide and narrow cover; saw blade rotational speed 3500 min⁻¹, fan motor frequency 50 Hz.

In order to improve the performance of chip removing system without interfering with the fan model structure several modifications were carried out as follows. Firstly, the shape change of lower shelter, minimizing its leakages as well as modification of the shape of the outlet channel in upper part were executed. The results of pressure distribution after that modifications are shown for both wide and narrow hood in Fig. 12–13 as “modified case”.

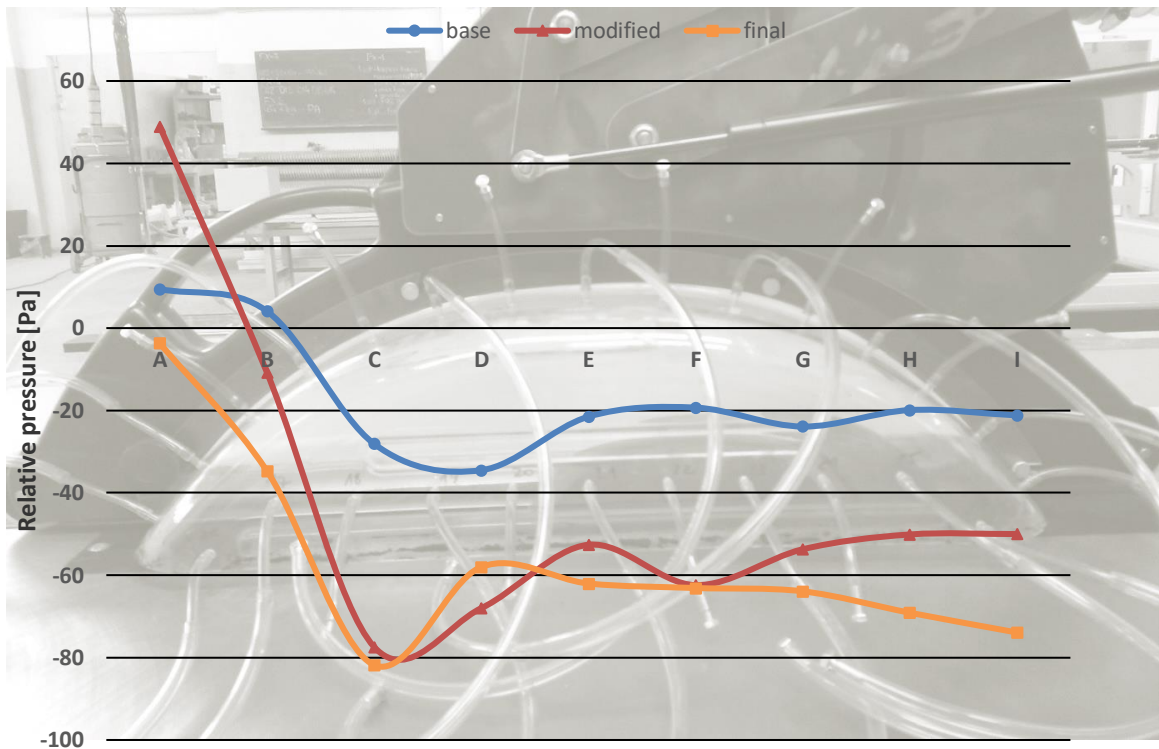

Fig. 12 Chosen results of the relative pressure distribution along the upper part of the wide cover.

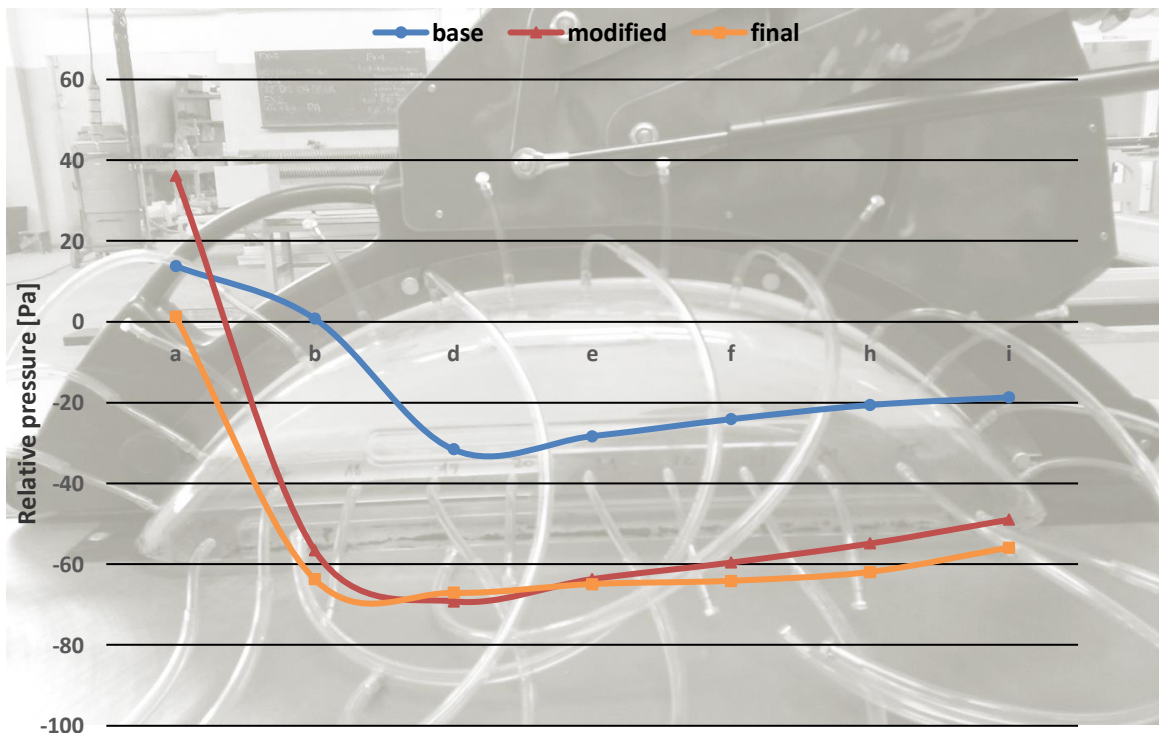

Fig. 13 Chosen results of the relative pressure distribution along the side part of the wide cover.

It can be seen that higher vacuum pressure was achieved in comparison with "base case" except for points "A" and "a".

A new design of the upper hood was proposed. Its final shape is already patented. It can also be seen in Fig. 12–13 (“final case”) that it resulted in satisfactory pressure distribution without modification of the fan construction, Fig. 14–15.



Fig. 14 The final shape of the upper hood.

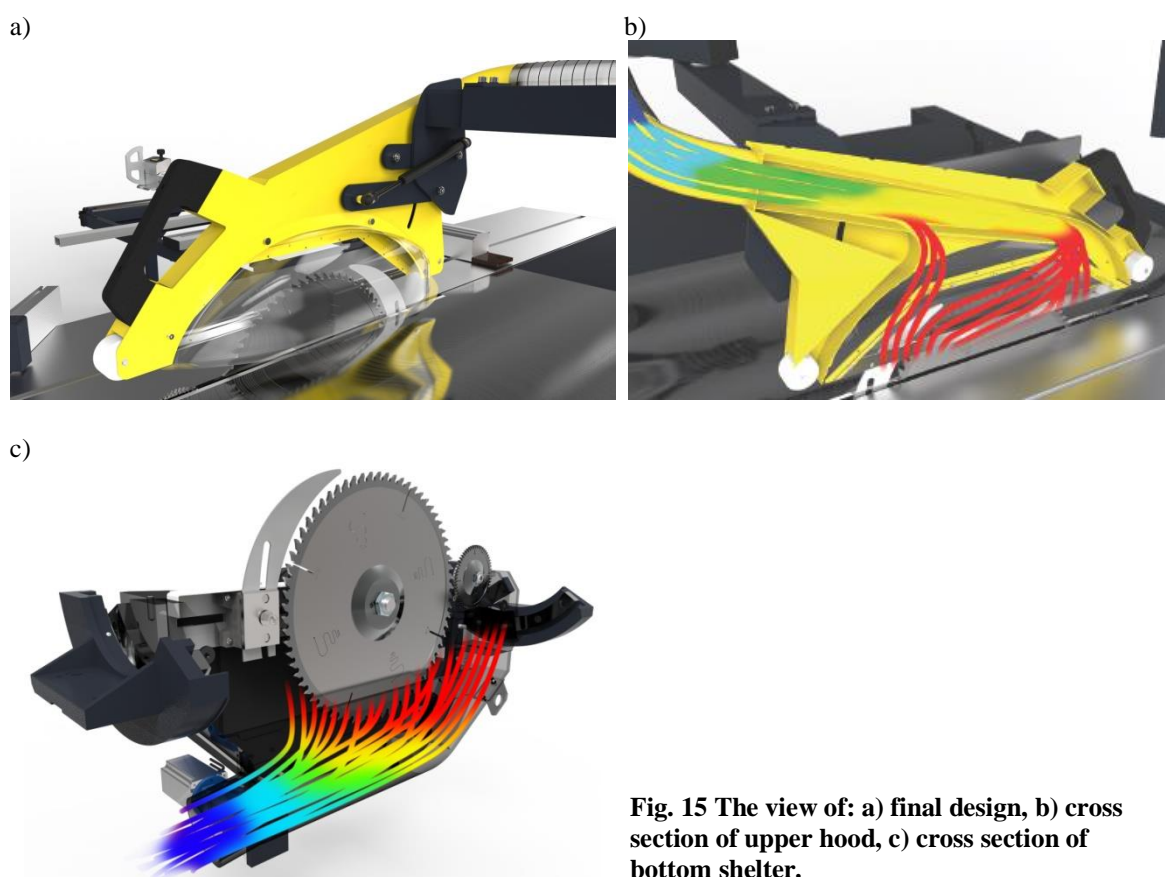

Fig. 15 The view of: a) final design, b) cross section of upper hood, c) cross section of bottom shelter.

CONCLUSIONS

The existing dust removing system in the analyzed woodworking machine did not provide efficient and satisfactory chip extraction from the working tool area. The empirical research and numerical modeling simulations proved that:

- in the area around the tool, insufficient vacuum pressure value could hinder the organized pneumatic transport of wood wastes;
- after several changes in the upper hood and lower shelter shapes of the suction system, all parts of the extraction system to obtain better conditions and provide efficient performance of chip removing system were redesigned and modified except the fan construction;
- the final design of the upper hood shape, which belongs to chip extraction system is shown in Fig. 15;
- the dimensions of the new wide upper hood inner dimensions are length 690 mm, high 175 mm and width 137 mm and the new narrow hood inner dimensions are length 690 mm, high 175 mm and width 42 mm respectively;
- from the main dimensions of the new wide and narrow upper covers the distance between the saw blade and the inside the new cover shape is 226 mm and 141 mm for saw blade \varnothing 300 mm and \varnothing 450 mm respectively and;
- the distance above the saw blade and the inside the new cover shape is 175 mm and 25 mm for saw blade \varnothing 300 mm and \varnothing 450 mm respectively.

REFERENCES

- ANSYS, Inc. 2016. ANSYS Fluent User's Guide, Release 17.2.
- BARAŃSKI, J., JEWARTOWSKI, M., WAJS, J., PIKAŁA T. 2016. Experimental analysis of chip removing system in circular sawing machine. In *Trieskove a Beztrieskove Obrabanie Dreva*, Technical University in Zvolen, 10: 25–29.
- BARAŃSKI J., PIKAŁA T. 2017. Application in circular sawing machines of the experimental results of investigations of the chip removing system operation. In *Annals of WULS, Forestry and Wood Technology*. no 100, pp. 199–205.
- BARAŃSKI J., JEWARTOWSKI M., WAJS J., ORŁOWSKI K., PIKAŁA T. 2018. Experimental examination and modification of chip suction system in circular sawing machine. In *Drvna Industrija*, 69(3): 223–230.
- BELJO LUČIĆ, R., KOS, A., ANTONOVIĆ, A., VUJASINOVIĆ, E., ŠIMIČIĆ, I. 2005. Svojstva usitnjenog materijala nastaloga pri mehaničkoj obradi drva. In *Drvna industrija*, 56 (1): 11–19.
- DZURENDA, L. 2007. *Sypká drevná hmota, vzduchotechnická doprava a odlučovanie*. 1st ed., Zvolen: Technical University in Zvolen. 182 p.
- FUJIMOTO, K., TAKANO, T. 2003. Mass concentration and particle size distribution of suspended during circular sawing. In *The Proceedings of the 16th International Wood Machining Seminar*. Matsue, Japan, pp. 724–731.
- FUJIMOTO, K., TAKANO, T., OKUMURA, S. 2011. Difference in mass concentration of airborne dust during circular sawing of five wood-based materials. In *J Wood Sci* 57: 149–154. <https://doi.org/10.1007/s10086-010-1145-y>
- HEMILLÄ, P., GOTTLÖBER, C., WEELLING, I. 2003. Effect of cutting parameters to dust and noise in wood cutting, laboratory and industrial tests. In *The Proceedings of the 16th International Wood Machining Seminar*. Matsue, Japan, pp. 375–384.
- HLÁSKOVÁ, L', ROGOZINSKI, T., DOLNY, S., KOPECKÝ, Z., JEDINÁK, M. 2015. Content of respirable and inhalable fractions in dust created while sawing beech wood and its modifications. In *Drewno* 58 (194): 135–146.

- KMINIAK, R., ORLOWSKI, K.A., DZURENDA, L., CHUCHALA, D., BANSKI, A. 2020. Effect of Thermal Treatment of Birch Wood by Saturated Water Vapor on Granulometric Composition of Chips from Sawing and Milling Processes from the Point of View of Its Processing to Composites. In *Appl. Sci.*, 10, 7545.
- KOHLER, B. 1995. Wood dust and cancer. National Report - Health, Safety and Environment, IARC, France.
- KOPECKÝ, Z., ROUSEK, M. 2007. Dustiness in high-speed milling. In *Wood research*, 52(2): 65–76.
- KOS, A., BELJO LUČIĆ, R. 2004. Factors influencing particle size distribution of oak sawdust developed during circular sawing. In *Trieskove a Beztrieskove Obrabanie Dreva*. Zvolen: Technical University in Zvolen, Vol. 4, pp. 131–137.
- KUČERKA, M., OČKAJOVÁ, A. 2018. Thermowood and granularity of abrasive wood dust. In *Acta Facultatis Xylogiae Zvolen*, 60(2): 43–51. DOI: 10.17423/afx.2018.60.2.04.
- OČKAJOVÁ, A., BELJO LUČIĆ, R., ČAVLOVIĆ, A., TERAŇOVÁ, J. 2006. Reduction of dustiness in sawing wood by universal circular saw. In *Drvna industrija*, 57(3): 119–126.
- OČKAJOVÁ, A., KUČERKA, M., BANSKI, A., ROGOZIŃSKI, T. 2016. Factors affecting the granularity of wood dust particles. In *Chipand Chipless Wood working Processes*, 10(1): 137–144.
- ORŁOWSKI K., CHUCHAŁA D., MUZIŃSKI T., BARAŃSKI J., BANSKI, A., ROGOZIŃSKI T. 2019. The effect of wood drying method on the granularity of sawdust obtained during the sawing process using the frame sawing machine. In *Acta Facultatis Xylogiae, Zvolen*, 61(1): 83–92.
- ORLOWSKI, K. A., DUDEK, P., CHUCHALA, D., BLACHARSKI, W., PRZYBYLINSKI, T. 2020. The Design Development of the Sliding Table Saw Towards Improving Its Dynamic Properties. In *Appl. Sci.*, 10, 7386.
- PAŁUBICKI, B., ROGOZIŃSKI, T. 2016. Efficiency of chips removal during CNC machining of particleboard. In *Wood Research*, 61(5): pp. 811–818.
- ROGOZINSKI, T., CHUCHALA, D., PĘDZIK, M., ORLOWSKI, K., DZURENDA L., MUZINSKI, T. 2020. Influence of drying mode and feed per tooth rate on the fine dust creation in pine and beech sawing on a mini sash gang saw. In *Eur. J. Wood Prod.* <https://doi.org/10.1007/s00107-020-01608-8>.
- Decision No 1600/2002/EC of the European Parliament and of the Council of 22 July 2002 laying down the Sixth Community Environment Action Programme. Official Journal of the European Communities, 10.9.2002: L 242/1 - L 242/15 <http://eur-lex.europa.eu/legal-content/EN/TXT/PDF/?uri=CELEX:32002D1600&from=EN> (accessed on October 12, 2020)
- Operation manuals of panel saws.
- Testo Technical Data (<https://www.testo.com/resources/51/43/180850f3d452/testo-480>).

ACKNOWLEDGMENTS

It is kindly acknowledged that this work has been carried out within the framework of the project POIR.01.01.01-00-05888/15, which has been financially supported by the European Regional Development Fund. The authors would also like to acknowledge the company REMA S. A. in Reszel (Poland), which is the beneficiary of the project, for helping out in the experimental part of this work. The data included in this article was partially presented during 23rd International Wood Machining Seminar, Warsaw, Poland. The sliding table saw FX550, in which the presented suction system is applied, was awarded with the Gold Medal at the International Fair DREMA in Poznan, Poland in 2017.

AUTHORS ADDRESSES

Jacek Baranski (ORCID id: 0000-0001-9040-9181)
Gdansk University of Technology
Faculty of Mechanical Engineering and Ship
Technology
Narutowicza 11/12
80-233 Gdansk, Poland

Przemyslaw Dudek
REMA S.A.
B. Chrobrego 5
11-440 Reszel, Poland