

Computational Fluid Dynamic study on the wind characteristics of a multifunctional building system model in developed coastal cities

Mateusz Gerigk¹, Jacek Jachowski²✉

¹ Gdańsk University of Technology, Department of Housing and Architecture of Public Buildings
11/12 Gabriela Narutowicza St., 80-233 Gdynia, Poland
e-mail: mateusz.gerigk@pg.edu.pl

² Gdynia Maritime University, Department of Ship Operation
81-87 Morska St., 81-225 Gdynia, Poland
e-mail: j.jachowski@wn.umg.edu.pl

✉ corresponding author

Key words: architectural design, Computational Fluid Dynamic (CFD), multifunctional building, system model, optimization, sustainable environment

Abstract

This paper presents an approach for providing innovative technology by applying fluid mechanics to the field of architectural design. The aim is to make a building's shape profitable and strengthen environmental protection by using the wind force to create an integrated wind absorption definition for a multifunctional building system model. Furthermore, taking control of the wind flow over an object can have an impact on not only the designed object itself but also on its surroundings. In modern coastal cities there are issues associated with the wind and ventilation that need to be solved. The presented system model and the calculations conducted are part of the new definition of a multifunctional object and the wind force as a significant subsystem. Systematizing this scope can be useful in design practice.

Introduction

The new trend of architectural design is becoming very similar to ocean engineering. Advanced calculation procedures are becoming a standard part of the building design process. There are many examples of the practical use of Computational Fluid Dynamics (CFD) calculations in the design process (Aydin & Mirzaei, 2017; Naboni, Lee & Fabbri, 2017; Wu & Hsieh, 2017; Zhong, Zhang & Tamura, 2019). The trend of using CFD seems to be increasing (Jo, Jones, & Grant, 2018) which is beneficial in predicting the optimal structural solutions. Harnessing the potential of natural wind power at the design stage tends to create a more environmentally friendly structure that fits into a dense urban environment (Allard, Ghiaus & Szucs, 2009).

By analyzing global wind power installations (Archer & Jacobson, 2005) it can be seen that water-side land is the most profitable land for the application of power generating installations. Furthermore, coastal urban areas are currently characterized by the most dynamic development (Barragán & de Andrés, 2015). Along with the intensification of spatial development there is a concentration of urban tissue, where the control of air flow shows a large scope for the development of knowledge in the field of architectural structural design. Currently cities are characterized by intensive land use: as has been observed in the literature (Gerigk, 2017), multifunctional structures are one of the predominant types of buildings in today's urban agglomeration.

The topic of optimizing wind characteristics is suitable for the surroundings of a building (Shi,

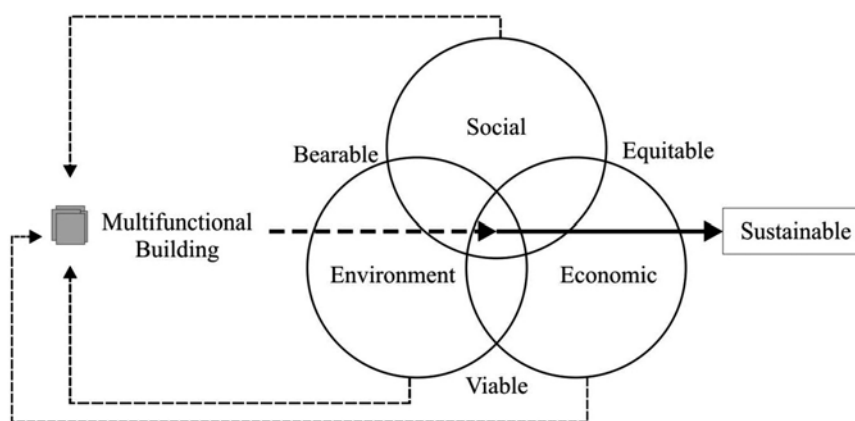

Figure 1. Scheme of the influence of a multifunctional building on sustainable development, presented in a Venn diagram (Gerigk, 2017). Venn diagram based on the literature (Lozano, 2008)

Lu & Li, 2015), where the building's impact on the environment is most significant. However, optimization of wind characteristics is also dependent on how the designed structure makes use of the wind force (Kim, Jeon & Kim, 2016). Wind force can be used to induce wind flow for ventilation, both inside and outside the building, as well as to generate electricity using wind turbines. Wind power is one of the most important environmental factors that are required to be included in architectural design in order to create modern multifunctional buildings.

Creating a sustainable environment is a priority for modern cities. Some projects contain pro-ecological elements, but their presence depends on the expectations of the investors. Not every design office has adequate knowledge regarding the implementation of advanced calculations in the use of wind energy. Within design optimization, it can provide a multifunctional building system model that can bring benefits for the developed environment.

Multifunctional buildings are one of the predominant types of buildings in today's urban agglomeration. However, it is difficult to introduce any systematic change in developments that already exist. It can be said that the integration of functions in one building is currently associated with the expectations of an investor who defines his demands for the project. From a theoretical and practical point of view, it would be beneficial to combine functions with respect to the wider environment; such an approach is beneficial not only for functional reasons. Multifunctional systems also have a social, economic and environmental dimension (Gerigk, 2017), where the CFD approach is necessary to develop the project in the most efficient way. Creating a multifunctional building system model is a systematic way to define the design process in order to achieve the basic values of sustainable development (United Nations

World Commission on Environment and Development, 1987) (Figure 1).

Multifunctional building system model

The holistic representation of a multifunctional building system is a model that contains all the characteristics of a building's design. This is a combined theoretical model dedicated for a building's complex system. By gathering the total amount of information about a multifunctional building project, it can be described as a Multi-Criteria Model (MCM). Embracing all of the model's components in a logical structure is crucial for the model's structure. The Multi-Criteria Model is developed by defining the multifunctional building system, the basic criteria set and the stakeholder group and engaging them with the building's life cycle phases.

The Multifunctional Building System (MBS) is defined by three main subsystems. The first two subsystems are the Internal Functional System (IFS) and the External Functional System (EFS). The third one is the External Environment System (EES); this system is presented in Figure 2. The MBS is the representation of all the physical elements that are included in the building project.

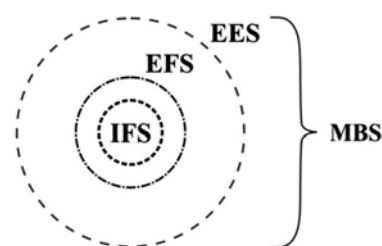

Figure 2. The Multifunctional Building System scheme

The Internal Functional System (IFS) is represented by the subsystems of the Functional System

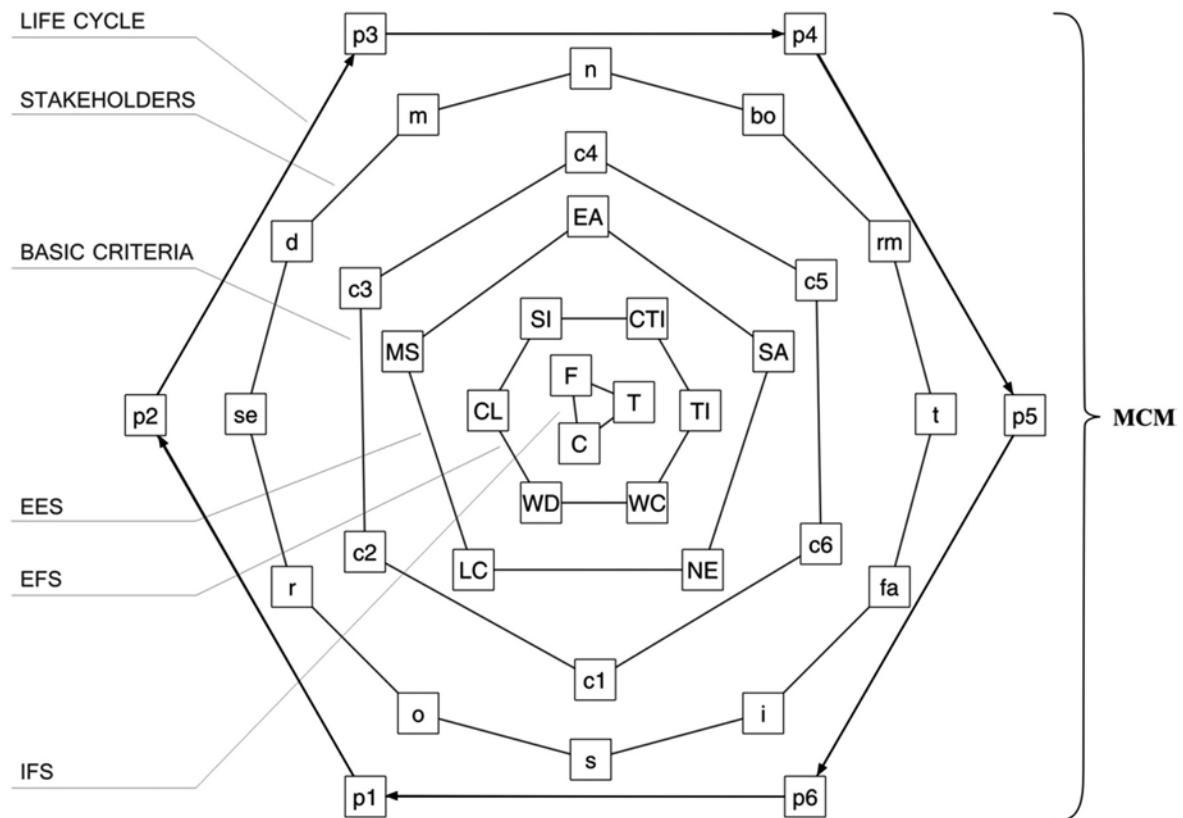

Figure 3. The Multi-Criteria Model scheme

(F), the Construction System (C) and the Technology System (T). This subsystem refers to the determined utilities that the building's design tends to satisfy.

The External Functional System (EFS) includes Social Infrastructure (SI), Transportation Infrastructure (TI), City Logistics (CL), City Technical Infrastructure (CTI), Waste Disposal (WD), and Weather Conditions (WC). The external parts of the subsystem are the location elements that connect the building to the surrounding agglomeration.

The External Environment System (EES) is defined by Social Aspect (SA), Legal Conditions (LC), Management System (MS), Economic Aspect (EA) and Natural Environment (NE). The external environmental elements impose all the basic requirements for the building project.

The designed multifunctional building's output depends on the defined Basic Criteria set which are: aesthetics (c1), functionality (c2), natural environment protection (c3), system safety (c4), system effectiveness (c5), and functional flexibility (c6). This set represents the basic requirements the designed structure must provide to the built environment, and all the stakeholders are obligated to implement them.

The Stakeholder Group in the multifunctional building project are: the building owner (bo), the

tenants (t), the staff (s), the occupants (o), the neighbors (n), the municipality (m), the regulators (r), the designer (d), specialist engineers (se), the risk manager (rm), the insurer (i), and the fire appraiser (fa).

In order to define each stage of the project, it is necessary to construct the building's project life cycle. It contains the following phases: the initial work (p1), the concept (p2), the project (p3), construction (p4), exploitation (p5) and finally the waste phase (p6).

Figure 3 presents the abovementioned components combined into one system, where they form the Multi-Criteria Model (MCM).

The presented model has circular layers composed of the presented sets of variables. The multifunctional building's design process depends on the formation of relationships between the individual multilayer elements resulting in the next steps required to complete the project. This is the basis for the system's development.

The multifunctional building's wind absorption subsystem

In order to carry out the CFD optimization of the designed multifunctional structure, the Wind Absorption System (WAS) must be defined. This

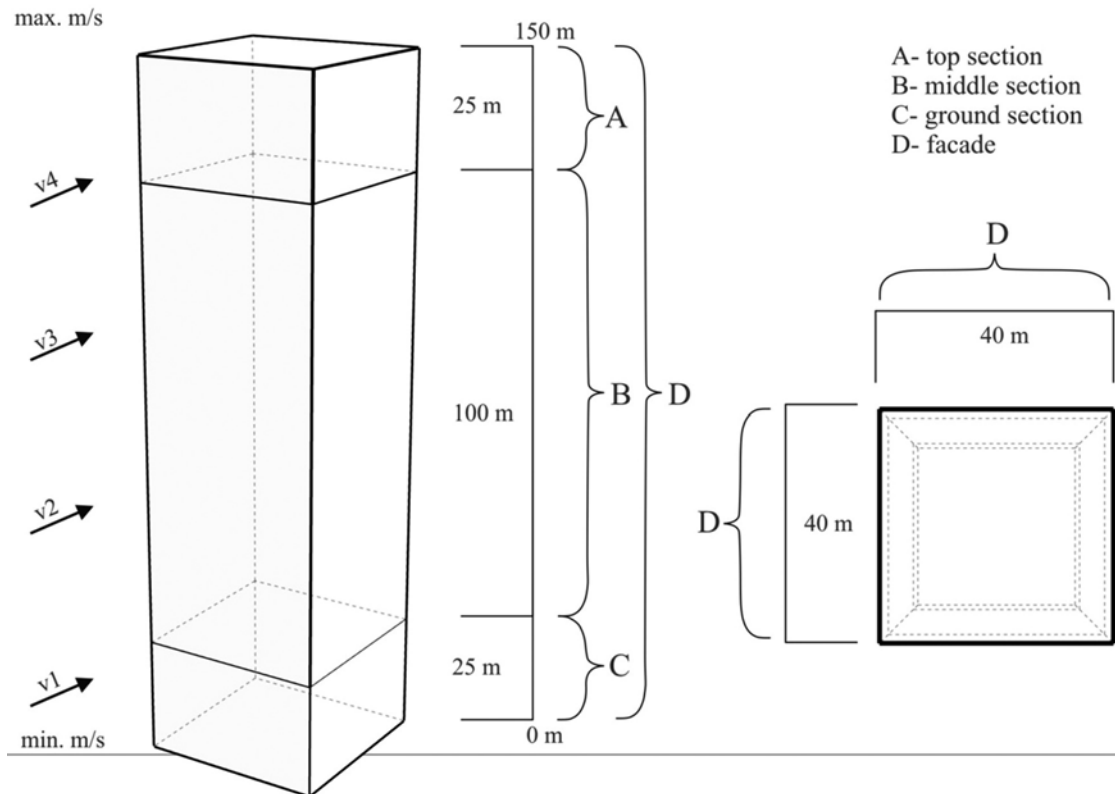

Figure 4. Wind analysis for the multifunctional building's structure scheme. Perspective on the left, top view on the right

concept is a set of measures that are used to shape the building's design, that make possible to use wind power to generate electricity and ventilation support.

The first parameter is the building's dimensions – Physical Volume (pv). In a simplified form the multifunctional structure is a high rise building about 150 meters high with a 40 by 40-meter base. In the Physical Volume, four sections can be distinguished, they are: (A) – the top section, (B) – the middle section, (C) – the ground section and (D) – the facade.

The second parameter is the Wind Speed (ws). For the purpose of this theoretical example the wind speed is not precisely defined but its strength in meters per second is defined for the minimum (v_1) near the ground, the maximum (v_4) in the top part, and (v_2, v_3) in the middle part of the building. The wind velocity is simplified, depending on the wind profile's interaction with the parts of the building. The wind analysis for a multifunctional building's structure scheme with the parameters presented above is as shown in Figure 4.

The Wind Absorption System (WAS) is defined using a compilation of characteristics presented above, as shown in Figure 5. This subsystem's main aim is to make the best use of the wind conditions, so the building's section nodes are connected to the correct wind flow.

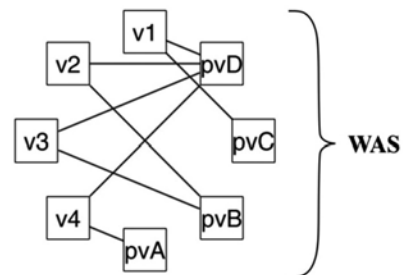

Figure 5. Wind Absorption System (WAS) scheme

Connections between the subsystem's nodes are defined by the strength of the wind and its location. In Figure 6, the Wind Absorption System is joined to the Multi-Criteria Model as part of the complex system. The implementation of the wind absorption system is a process that determines how the wind power can be used and what influence it will have on the project.

CFD optimization of the wind characteristics

The CFD optimization of the wind characteristics can be carried out by modifying the building's shape. Depending on its purpose, the wind power can be useful in four ways: The first is to generate electrical energy, the second is to improve the

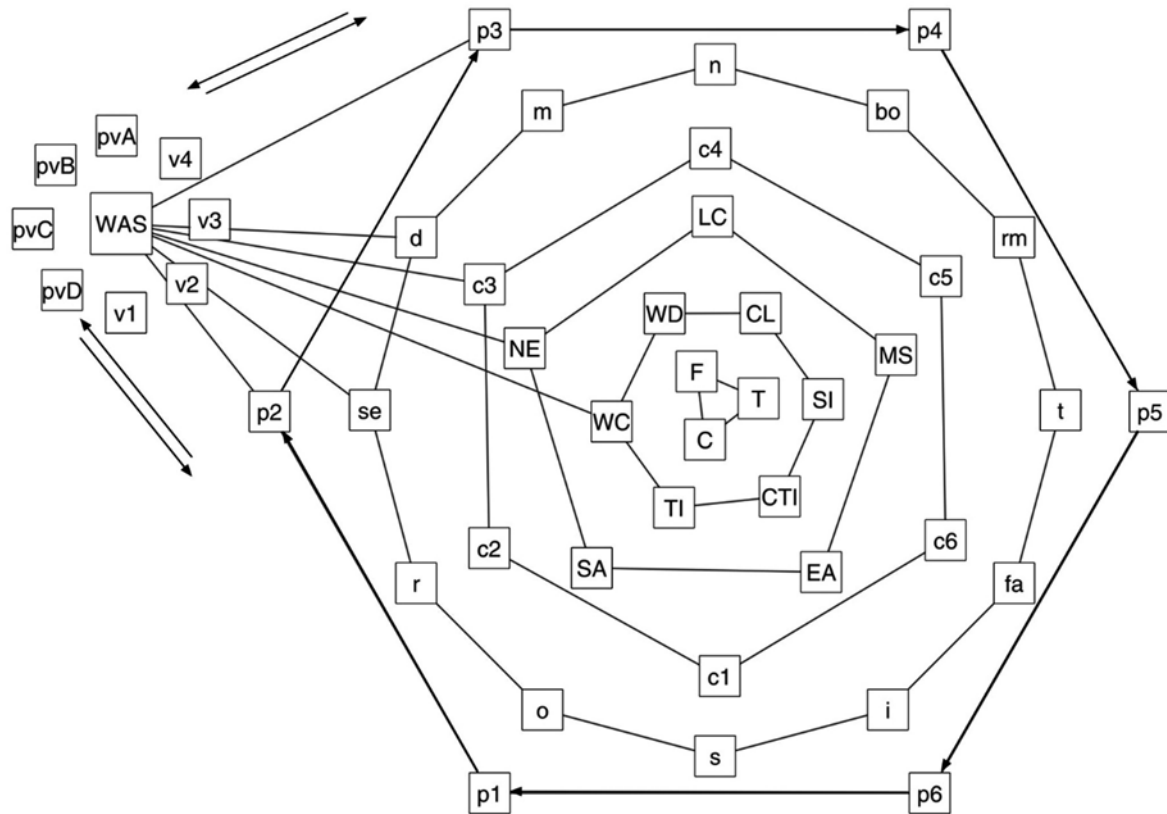

Figure 6. Multi-Criteria Model (MCM) and Wind Absorption System (WAS) integration scheme

building's ventilation, the third is to provide wind control for the surroundings for the users' comfort, and finally adapting the building to this phenomenon can improve the structure's rationalization.

In Figure 7, depending on the building's parts, the CFD optimization possibilities are presented.

Figure 7a presents the modification of the top section. In the top part of the building, the wind speed is the most favorable; by creating a wind inlet, it is possible to increase the wind speed.

In Figure 7b the situation is the same as in previous figure but with one exception; the wind is weaker.

For sections A and B, the most important goal is the possibility of using the renewable energy source through the use of wind turbines.

The modification of the ground section is shown in Figure 7c. The ground floor modification provides an undercutting effect that can have a positive effect on the city's airflow. This can have the benefit of minimizing the effect of the strong ventilation at ground level for pedestrians. Ensuring adequate ventilation can improve the living conditions in this space. However, only operating within the basement may not be sufficient, especially in a dense urban structure. It is possible to shape the facade in a way that would allow a supply of

fresh air to be provided to the city. In addition, it is possible to shape the facade so that polluted air from the ground floor of the building is carried up and ejected from the upper part of the building as shown in Figure 7d, where the wind flow is depicted by arrows.

Conclusions

In this paper, an integrated Wind Absorption System (WAS) has been defined for a multifunctional building's system model. The building's shape is profitable, and strengthens the environmental protection through the use of the wind force. By creating inlets and places for wind turbines to be located it is possible to produce electricity in a more efficient way. Controlling the building's shape near the ground and on its facade can solve the problem of a non-ventilated city center and make the city a more comfortable space for pedestrians. The use of CFD for the Wind Absorption System can improve the design of multifunctional buildings in developed coastal cities. From the analysis the building scale is defined as a high-rise object, so it can make the most of the wind conditions. The improvement of the presented Multi-Criteria Model with the Wind Absorption System has significantly developed

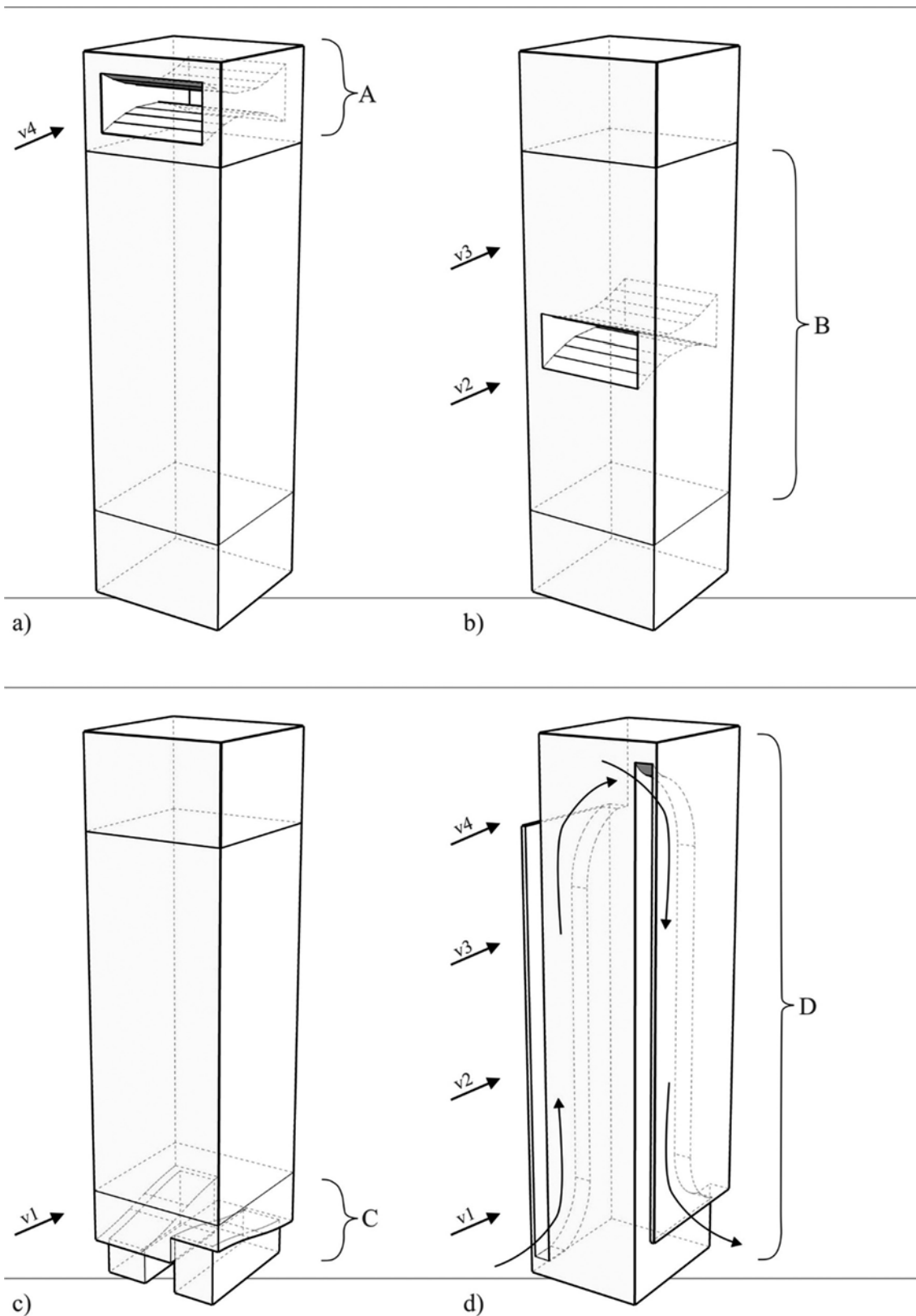

Figure 7. A multifunctional building's CFD shape optimization scheme; a) Optimization of the top section (A); b) Optimization of the middle section (B); c) Optimization of the ground section (C); d) Optimization of the facade (D)

the possibilities of the pro-ecological development of a building and its surroundings. Following the Multi-Criteria Model process, the Wind Absorption

System depends on a specialist engineer to calculate the optimal shape of the building. As the theoretical model has been presented in this work, the next step

will be to define the design procedure and the computational data.

References

1. ALLARD, F., GHIAUS, C. & SZUCS, A. (2009) Natural Ventilation in High-Density Cities. In: E. Ng (Ed.) *Designing High-Density Cities: For Social and Environmental Sustainability* pp. 137–162. Routledge.
2. ARCHER, C.L. & JACOBSON, M.Z. (2005) Evaluation of global wind power. *Journal of Geophysical Research D: Atmospheres* 110 (12), pp. 1–20.
3. AYDIN, Y.C. & MIRZAEI, P.A. (2017) Wind-driven ventilation improvement with plan typology alteration: A CFD case study of traditional Turkish architecture. *Building Simulation* 10, 2, pp. 239–254.
4. BARRAGÁN, J.M. & DE ANDRÉS, M. (2015) Analysis and trends of the world's coastal cities and agglomerations. *Ocean & Coastal Management* 114, pp. 11–20.
5. GERIGK, M. (2017) Multi-Criteria Approach in Multifunctional Building Design Process. *IOP Conference Series: Materials Science and Engineering* 245, 052085.
6. JO, S.J., JONES, J. & GRANT, E. (2018) Trends in the application of CFD for architectural design. *ARCC Conference Repository*. <https://doi.org/10.17831/rep:arcc%y489>.
7. KIM, H.G., JEON, W.H. & KIM, D.H. (2016) Wind resource assessment for high-rise BIWT using RS-NWP-CFD. *Remote Sensing* 8 (12), 1019. <https://doi.org/10.3390/rs8121019>.
8. LOZANO, R. (2008) Envisioning sustainability three-dimensionally. *Journal of Cleaner Production* 16, 17, pp. 1838–1846.
9. NABONI, E., LEE, D.S.-H. & FABBRI, K. (2017) Thermal Comfort-CFD maps for Architectural Interior Design. *Procedia Engineering* 180, pp. 110–117.
10. SHI, Y., LU, M. & LI, W. (2015) Study on Optimization of Architectural Shape Based on Wind Environment: A Study in Taiyuan, China. *Civil Engineering and Architecture* 3 (5), pp. 99–106.
11. World Commission on Environment and Development (1987) *Our Common Future*. Oxford: Oxford University Press.
12. WU, K.L. & HSIEH, C.M. (2017) Computational fluid dynamics application for the evaluation of a community atrium open space design integrated with microclimate environment. *Applied Ecology and Environmental Research* 15 (4), pp. 1815–1831.
13. ZHONG, W., ZHANG, T. & TAMURA, T. (2019) CFD Simulation of Convective Heat Transfer on Vernacular Sustainable Architecture: Validation and Application of Methodology. *Sustainability* 11 (15), 4231.