

DESIGN AND CONSTRUCTION OF TILTED WALLS IN ACCORDANCE WITH CODES' PROVISIONS ON THE EXAMPLE OF THE CONSTRUCTION OF THE MUSEUM OF THE SECOND WORLD WAR IN GDAŃSK

*Nagrodzka-Godycka K., Wiśniowska M.
Gdańsk University of Technology
Gabriela Narutowicza 11/12, 80-233 Gdańsk, Poland*

SUMMARY

The purpose of this article was to introduce the design and construction process of tilted walls in accordance to codes' rules. The construction of the Museum of the Second World War in Gdańsk (Fig.1) was chosen to be an example of its successful use in practice. Theoretical knowledge was based on European Standards (EN 1990 [1], EN 1991 [2,3], EN 1992 [4]) and *fib* Model Code for Concrete Structures [5]. Both designing and building process was taken into consideration. One of the Authors was working as a site engineer on the construction of the Museum what provided an inside view on the matter.



Fig. 1. Building of the Museum of the Second World War in Gdańsk- visualization

1. MUSEUM OF THE SECOND WORLD WAR IN GDAŃSK

1.1.Characteristics of the building

The design of the building of the Museum of the Second World War in Gdańsk was chosen in the international architectural competition. The winning architecture has been described as "a new symbol of Gdańsk", "a new icon" or a "sculptural design". Building site started in July 2012 with building of a dry pit and Museum's first level which is over 14 meters underground. Museum, which floor surface reaches over 30 000 m², is divided into three parts: the underground - which is devoted to the exhibitions, car parks and technical background, the administrative building which is an isolated structure for administrative purposes and the last part, reaching over 40 meters above the ground - the leaning "tower" mainly for education and leisure.

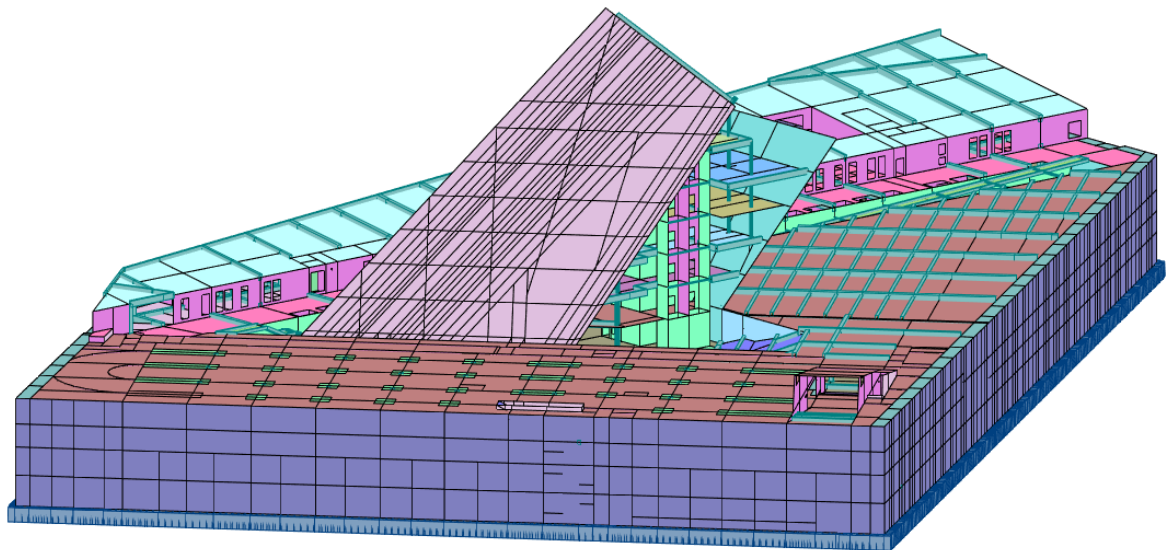

Fig. 2. FEM model of the building

The structure of the building has a complicated, varying geometry on each floor. To provide structure stability and analyse all impacts such as environmental loads (snow, wind) and live loads on the structure, an exact 3d model of the whole building was made to conduct FEM analysis which is presented in Fig. 2.

1.2. Tilted walls

The above-ground section is a leaning triangular prism with all the walls being inclined on different angles. The most tilted wall is constructed on the angle of 56 degrees, the others - 65, 72 and 75 degrees. Among many challenges during the construction of the Museum the most spectacular, in Authors' opinion, was the construction of the falling off wall. An example of a stress distribution in the falling off wall is presented in Fig. 3.

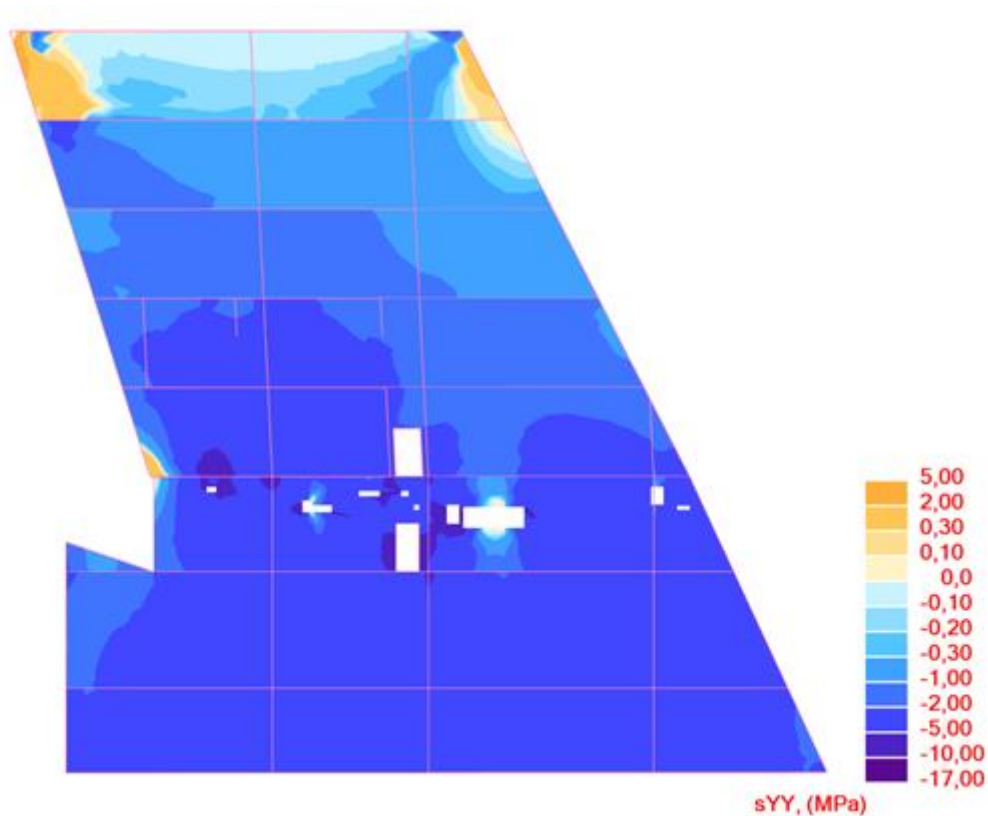

Fig. 3. Map of a stress distribution in a fall off wall

Concrete class for most construction elements was designed as C30/37, yet in case of walls it was increased to C35/45. In addition architectural concrete was used what required special treatment and technology. In case of compacting concrete internal vibrators were used, the time of removing formworks was also restricted, as keeping it too long may change the color of concrete. Reinforcement bars were made of steel BSt 500/AIIN.

Structural stability of the tilted walls was reached mainly by monolithic connections with interfloor slabs. An exemplary construction of the connection between the two elements is presented in Fig. 4.

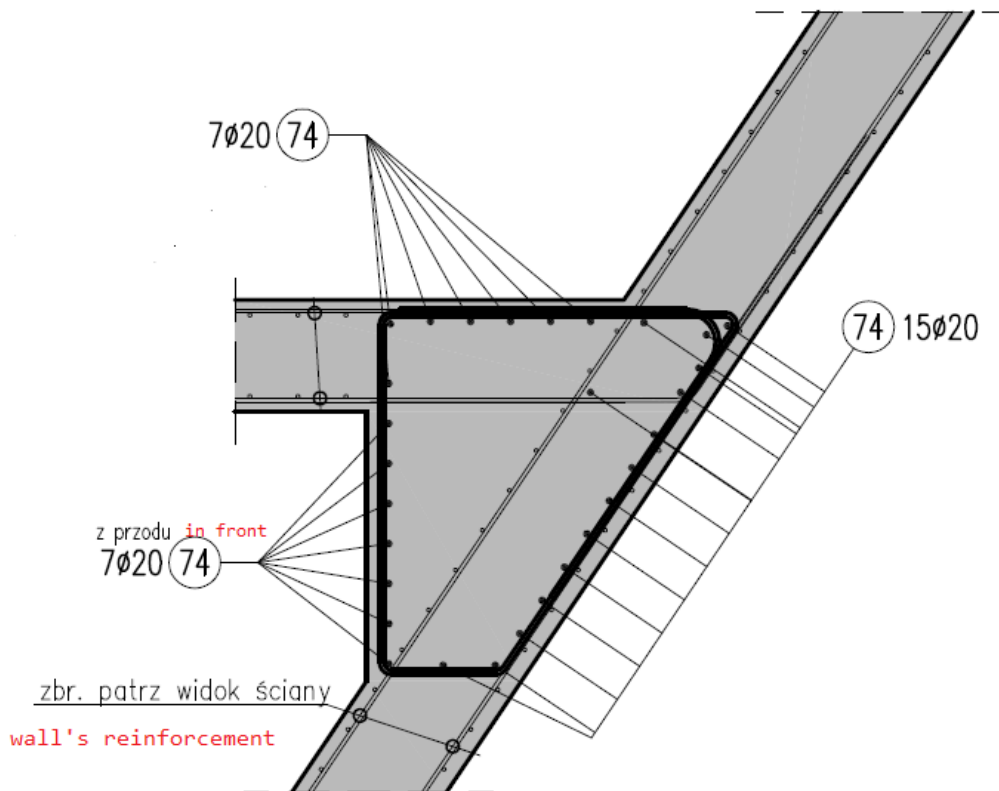

Fig. 4. Monolithic connection between tilted wall and slab.

Looking back at Fig. 2 it can be seen that on the highest floors there were no slabs connected to the falling off wall. To prevent distortions a special reinforced concrete beam was constructed that connected the falling off wall with a wall on the opposite side of the building (see Fig. 5). The beam reaching from one corner to another is supported by a column in the middle of its span.

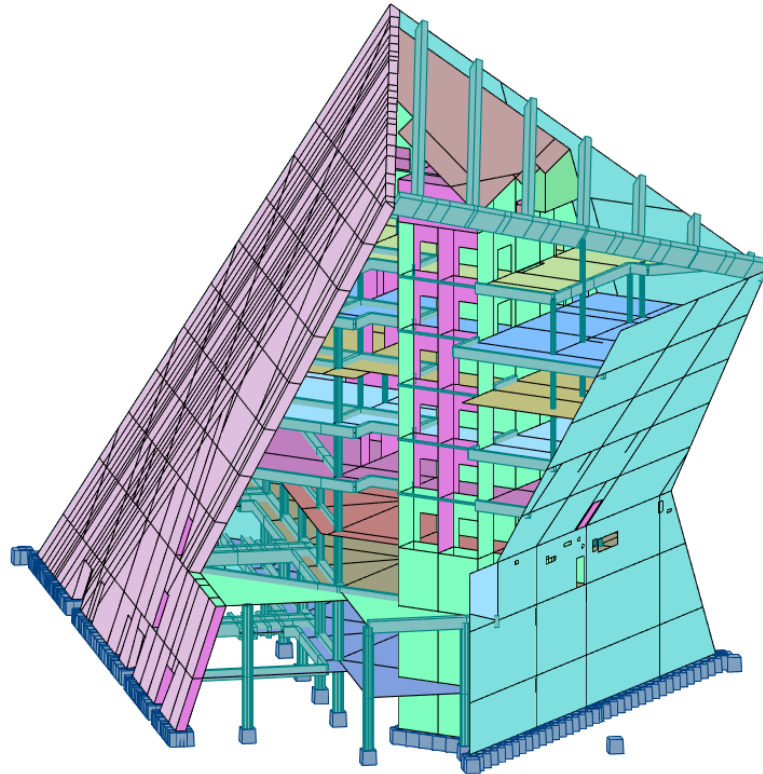

Fig. 5. FEM model with a view on the "connecting beam"

2. CODES' PROVISIONS REGARDING WALLS

2.1. Detailing of members

Both EN 1992-1-1:2004 [4] and fib Model Code for Concrete Structures [5] give rather curt provisions regarding the construction of walls. There is a minimum and maximum areas for vertical reinforcement ($A_{s,vmin}=0.002A_c$; $A_{s,vmax}=0.4A_c$) and minimum area for horizontal reinforcement ($A_{s,hmin}=\max(0.25A_{sv}, 0.001A_c)$) specified as well as distances between two adjacent bars (EN: $s_v \leq \min(3t; 400 \text{ mm})$; $s_h \leq 400 \text{ mm}$, MC: $s_v \leq \min(2t; 300 \text{ mm})$). Eurocode 2 [4] also suggests that the amount and proper detailing of reinforcement may be derived from strut-and-tie model, yet it seems unlikely to use it properly in such a complicated case of a tilted wall.

2.2. Durability and concrete cover to reinforcement

EN 1990:2002 [1] specifies five design working life categories lasting from 10 to 100 years. The design working life is the assumed period for which a structure is to be used for its intended purpose with anticipated maintenance but without major repair being necessary. Selection of one category affects later analysis including the choice of material properties (fatigue, creep, shrinkage) or required concrete cover. Although it is recommended in EN 1990 [1] to assume a design working life of 50 years for building structures, Museum was classified as a monumental building with a design working life of 100 years.

The concrete cover is the distance between the surface of the reinforcement closest to the nearest concrete surface. The nominal cover, according to EN 1992-1-1 [4] is a sum of a minimum cover (c_{min}) and an allowance in design for deviation (Δc_{dev}). While calculating the required concrete cover, Eurocode gives us a choice to decide on the value of Δc_{dev} between 0 and 10 mm. In case of such a complicated structures as tilted walls Engineers have a possibility to choose higher value for safety reasons.

2.3. Wind

The most unfavorable case of wind load on the fall off wall is suction which causes the increase of tensile. In Authors opinion wind load analysis that would specify pressure caused by suction was crucial. Yet modeling of wind actions presented in EN 1991-1-4:2005[3] does not cover a case of a wind acting on a falling off wall. As the value of pressure differs depending on the angle of the roof construction, the same should be assumed in case of a tilted wall. Therefore to complete code's requirements, solutions proposed in literature were used [6].

2.4. Load arrangements

EN 1991-1-1:2002 [4] suggests that where imposed loads from several storeys act on walls, the total imposed loads may be reduced by a factor $\alpha_n = \frac{2+(n-2)\psi_0}{n}$, where n is the number of storeys ($n>2$) and ψ_0 is in accordance with EN 1990 [1], Annex A1, Table A1.1. In case of Museum the reduction factor, α_n , on the highest, 7th floor could be about 0,7 - 0,8. Yet for safety reasons there was barely no reduction made in case of tilted walls.

3. CONCLUSIONS

The aim of the article was to assess to what extend are Codes helpful while dealing with non - standard elements. Unlike structural advance, Standards seem to analyse only basic cases and elements. It is Structural Engineers' job to use their knowledge and experience to fit those basic guidelines for more complicated forms. Fortunately although codes' recommendations seem curt, practice prove structural advance.

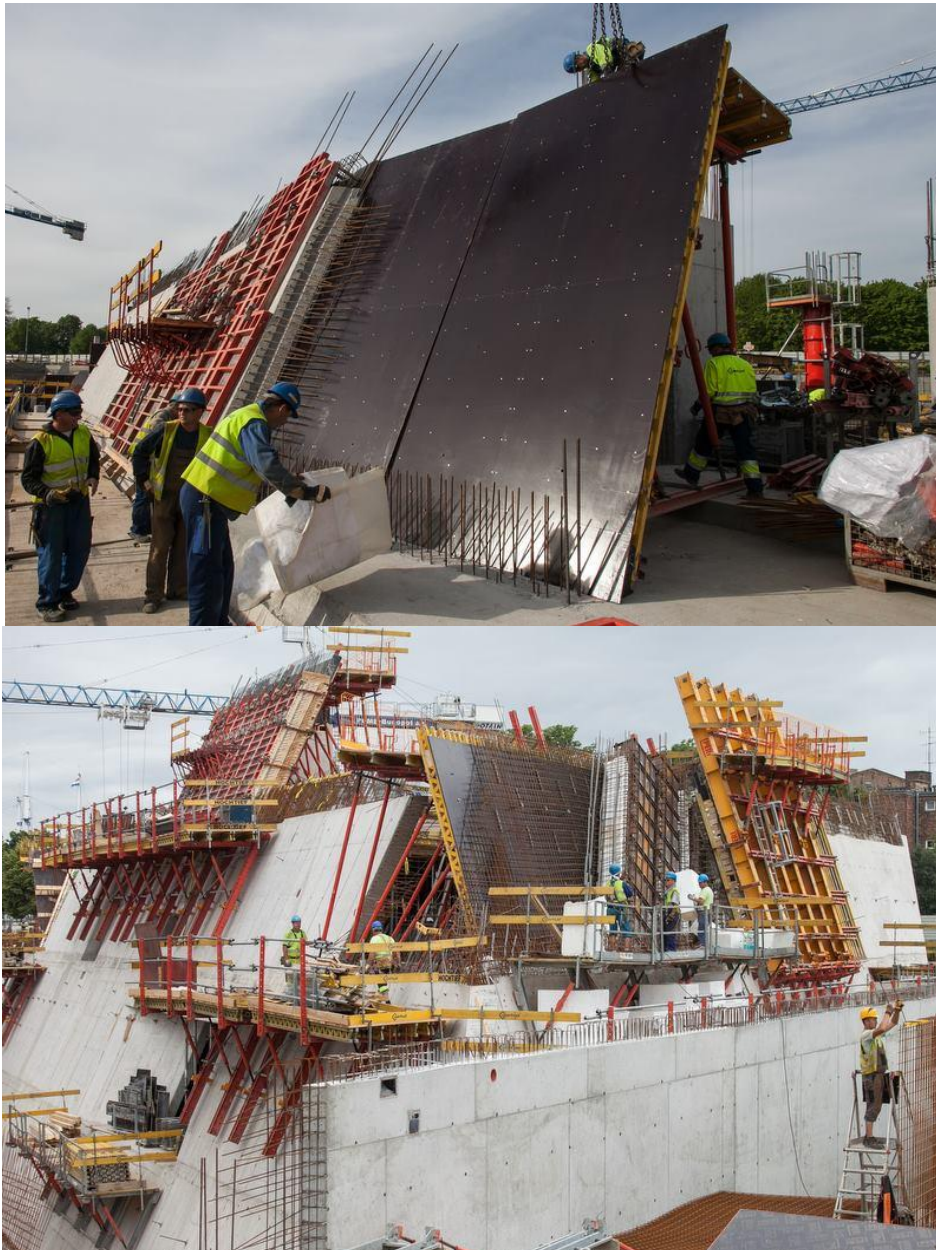

Fig. 6. Museum of the Second World War under construction. pict. R. Jocher

6. ACKNOWLEDGEMENTS

Authors wish to express their gratitude to the extensive help they got from the main constructor Paweł Gębka and his construction office PG-Projekt (<http://www.pg-projekt.pl/>).

7. REFERENCES

- [1] EN 1990:2002/A1:2005 Basis of structural design, 2005
- [2] EN 1991-1-1:2002 Actions on structures - Part 1-1: General actions - Wind actions, 2005
- [3] EN 1991-1-4:2005 Actions on structures - Part 1-4: General actions - Densities, self-weight, imposed loads for buildings, 2002
- [4] EN 1992-1-1:2004 - Design of concrete structures. General rules and rules for buildings, 2004

- [5] fib Model Code for Concrete Structures 2010, Ernst und Sohn, Berlin, 2013; polish version: Ajdukiewicz A.: Pre - Norma Konstrukcji Betonowych fib Model Code 2010, tom 2, Stowarzyszenie Producentów Cementu, Polska Grupa Narodowa fib, 2014
- [6] Flaga A. "Inżynieria wiatrowa. Podstawy i zastosowania" Arkady, 2008