

# Detection of the Direct Sequence Spread Spectrum Signals with BPSK Modulation

Studański Ryszard<sup>1\*</sup>, Waś Radosław<sup>1\*\*</sup>, Studańska Agnieszka<sup>2\*\*\*</sup>

<sup>1</sup>Polish Naval Academy  
Śmidowicza 69, 81-103 Gdynia, Poland

<sup>2</sup>Gdańsk University of Technology  
Gabriela Narutowicza 11/12, 80-233 Gdańsk-Wrzeszcz, Poland

## Abstract

This paper presents a method of the DS CDMA signals with BPSK modulation detection through the examination of the enhanced signal spectrum density. On the base of experiments carried out on the real radio communication signals the impact of a narrowband emission occurring in the examined frequency band on the detection process effectiveness was shown. The results of the experiment aimed at the detection of the satellite navigation system GPS signals are presented.

**Keywords:** detection, DS CDMA, signal processing, signal analysis

## Introduction

The rapid development of radio communication together with innovativeness of technologies used in control structures and precision mechanical engineering, creates the possibility to implement them in remotely controlled unmanned vehicles (UVs) and mobile platforms dedicated to military and special purposes. From a viewpoint of the specific of the tasks which are to be realized on a modern battlefield (i.e. reconnaissance) the issue of providing an efficient yet secretive and jamproof data transmission between an UV and an operator console or a command system becomes not irrelevant.

One of the methods of increasing the resilience of wireless communication systems to interference signals is the use the DS SS (Direct Sequence Spread Spectrum) signals. Its unquestionable advantage is the possibility of transmission on very low power levels. It can be expected that if the adversary is using the DS SS signals, at the radio reconnaissance points, their radio power will be lower than the noise.

These types of signals can be detected with the correlation method [1, 2], or by the repeated aggregation of amplitude spectral density [3], as well as by the power spectral density (PSD) analysis of the exponential signal [4, 5].

## The Method for Detection of DS SS Signals by Power Spectral Density Examination of Exponential Signal

The method is based on rising the value of sampled values of received signal to the power of  $n$ , where  $n$  depends on the type of used digital angle modulation. The execution of such operation on the signal makes possible to observe a single spectral line in its spectrum that appears at the frequency  $n \cdot f_n$ , if the ratio of signal power to noise power has a sufficiently large value. Taking up the decision on a signal detection is relatively simply when the power of spectrally dispersed signal strength is greater than the noise power and there are not narrowband signals of a relatively high power. If the power of the DS SS signal is lower than the noise power, its spectrum is hidden in the noise.

If the input signal is squared, then in accordance with trigonometric relationship:

\*e-mail: r.studanski@amw.gdynia.pl

\*\*e-mail: radoslaw.was@gmail.com

\*\*\*e-mail: agnieszka.studanska@eti.pg.gda.pl



Fig. 1. T  
detection  
 $2f_n$  frequ

the app  
two tim  
observe  
 $A$  (the  
relation:

Thus  
higher th  
sidered,  
compon  
compon  
not be le  
of spectr  
rical to 0  
the value  
times sm  
tion by t  
Fig. 1.

The c  
by the pc  
included

## The Re

On a  
wideband  
following  
– wideb  
– vector  
– spectr  
– acquis  
– signal  
– omnid  
– satellit  
– 1525-  
– low nc  
– PC.

The d  
Fig. 2. Th  
two exper  
1) The de  
CDMA/



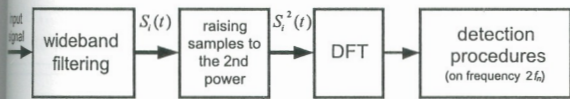

Fig. 1. The simplified diagram of signal transformation for the detection of the DS SS transmission with BPSK modulation, on frequency, using the DFT modulus.

$$\cos^2 \alpha = \frac{\cos 2\alpha + 1}{2} \quad (1)$$

the appearance of a spectrum component at frequency two times higher than the signal carrier frequency can be observed. Taking into account the input signal amplitude (the case for the DS CDMA signal survey), this relationship becomes:

$$A^2 \cos^2 \alpha = \frac{A^2 \cos 2\alpha + A^2}{2} \quad (2)$$

Thus, the signal amplitude at the frequency two times higher than  $f_n$  carrier equals  $A^2/2$ . If the worst case is considered, i.e. when sought after signal is among spectrum components determined by the DFT, then the spectrum component amplitude in the vicinity of frequency  $2f_n$  will not be less than  $A^2/2 \cdot \text{sinc}(0.5)$ . Moreover, the components of spectrum modulus determined by the DFT are symmetrical to  $0.5f_s$  (where:  $f_s$  - sampling frequency). In that case, the values of sought after spectral line modulus will be two times smaller. The successive stages of signal transformation by the DS SS signal detection method is depicted in Fig. 1.

The detailed description of the DS SS signal detection by the power spectral density analysis of squared signal is included in publication [1].

### The Results of Experiments Carried Out under Real Signals Impact

On a station for laboratory tests with the use of wideband physical signals under real signals impact the following devices were applied:

- wideband receiver;
- vector signal generator with built-in noise generator;
- spectrum analyzer;
- acquisition card (ADC);
- signal combiner;
- omnidirectional antenna to operate in the 0.3-10 GHz;
- satellite antenna to operate in the L band;
- 1525-1559 MHz bandpass filter;
- low noise amplifier (LNA);
- PC.

The diagram of the research station is depicted in Fig. 2. The configuration of devices secured conducting two experiments aimed to:

- 1) The detection of the wideband transmission of the DS CDMA with BPSK modulation with negative SNR

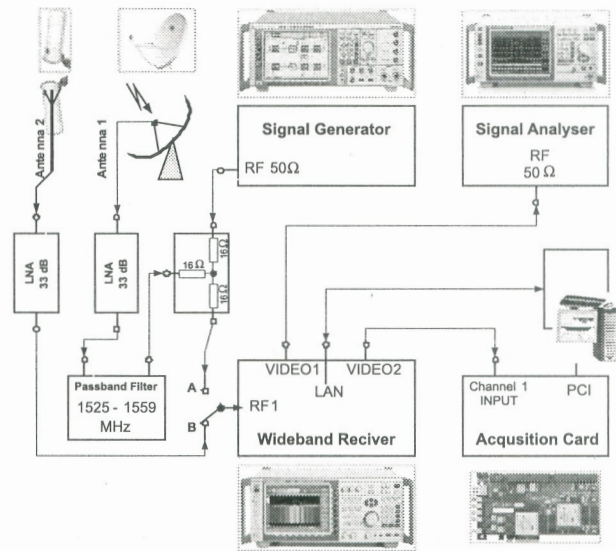

Fig. 2. The research station for laboratory tests with the use of wideband physical signals under real signals impact.

values, realized in the vicinity of the real and relatively strong signals which are narrowband interference for detection algorithms (RF1 input switch in the receiver in position A - Fig. 2);

- 2) The detection of the actual transmission of the DS CDMA with BPSK modulation and negative values of SNR as implemented in the GPS satellite navigation system (RF1 input switch in the receiver in position B - Fig. 2).

The first experiment was performed to detect the wideband transmission of the DS CDMA BPSK modulation with negative SNR values, carried out in the vicinity of real and relatively strong signals which is narrowband interference for the detection algorithms. The results for procedures performed with an inactive and active block for detection and elimination of narrowband signals are presented.

The experience was conducted in the measurement system, whose scheme is shown in Fig. 2 (RF1 input switch in the receiver in position A).

The aim of the experiment was to explore the possibilities of the DS SS signal with BPSK modulation detection in the presence of the real signals. For this as the background the satellite signals received in the frequency range 1525 MHz to 1560 MHz were used. The range of frequency band for the study was chosen in such a way that there was relatively strong narrowband interference in the vicinity of the sought after signal. The ratio of the maximum levels of the carrier power to the level of noise to signal "interfering" ranged from 10 to 20 dB (Fig. 3a). The parameters of generated the DS CDMA signal with BPSK modulation were selected in such a way to get a negative ratio of wanted signal to the noise power  $SNR = -10$  dB at the input of the acquisition card. The frequency range covered by the presence of the wideband direct-scattering spectrum indicated in Figs. 3a and 4a in a shaded box ( $B_{DS} = 2.44$  MHz,  $f_n = 21.4$  MHz on the IF). The results



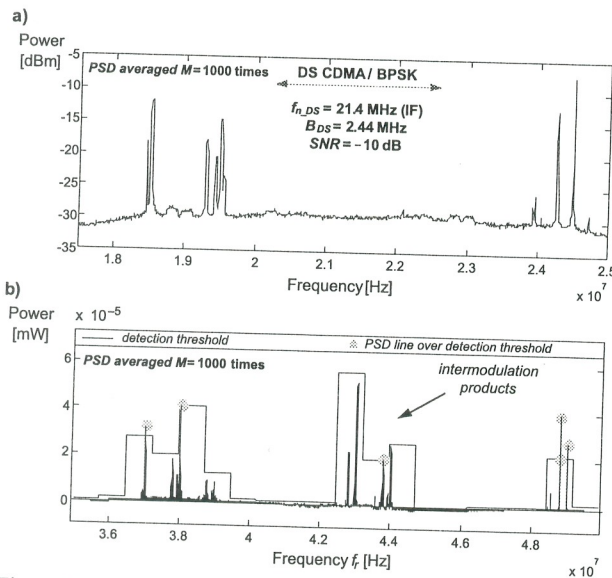

Fig. 3. Demonstration of PSD for signal samples on the input of the acquisition card (a) and results of the DS CDMA transmission in the absence of procedures for the elimination of narrowband signals.

of the experiment in the form of spectrum power density characteristics of the analyzed signal bandwidth and signal PSD of squared signal samples (in terms of twice the frequency) is shown in Fig. 3 and 4. In the presented spectral characteristics the FFT of size  $N = 2^{14}$  was used.

Analyzing the results obtained, it can be concluded that when the narrowband signals have not been subjected to elimination (Fig. 3b), the detection condition has been met for the six components of the spectrum. As it can be seen, none of the components exceeding the detection threshold does not come from the DS CDMA signal hidden in noise. Moreover, in the middle of the band appeared some unwelcome "false" components indicating the possibility of hidden signals in noise. These components are the products of intermodulation, arising from the squaring of signal samples.

To sum up the carried out experiments, it can be concluded that the detection process has been disturbed by narrowband signals, and the obtained results give an erroneous impression of the existence, in the analyzed band, the wideband DS SS signals with negative SNR values.

Therefore, the detection procedures were repeated on the same samples, but this time with the active block for detection and elimination of narrowband signals. As a result of implementation of appropriate procedures six narrow-band signals were detected and eliminated. Then obtained PSD which figure in the band analysis is presented in Fig. 4a. Such a prepared signal was processed in accordance with a signal detection algorithm for DS CDMA transmission with BPSK modulation using spectral analysis of the squared samples put in the time domain. The result in graphic form and the selected detection threshold is shown in Fig. 4b.

The experiment RF center frequency for input circuits of the receiver corresponded to the carrier frequency of generated spread spectrum signal, which in turn should

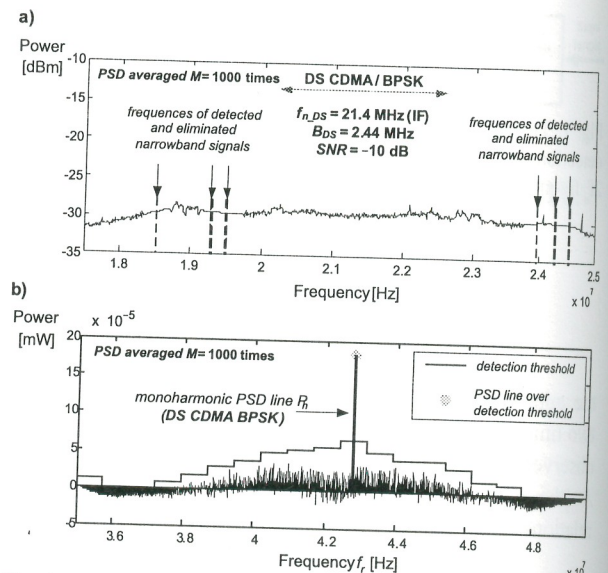

Fig. 4. PSD of the signal of fig. 3a after the elimination of narrowband signals (a) and the results of the procedures for detecting the DS CDMA transmission with BPSK modulation (b).

lead to the emergence of  $P_h$  component (harmonic coming from searching for DS CDMA signal) on the frequency 42.8 MHz, exactly twice the IF carrier of 21.4 MHz.

From the analysis of the obtained results (Fig. 4b), it can be assumed that in the observed case of component  $P_h$  the detection was correct and the carrier wave frequency (in the IF band) of the detected the DS CDMA signal with BPSK modulation was specified as 21.401978 MHz – what taking into account the PSD frequency resolution  $\Delta f_{PSD} = 6.103$  kHz (resulting from the size of the used FFT) is the result that deviates from the actual frequency of generated signal by 1.978 kHz, which is below the frequency resolution of the designated PSD.

### GPS Signal Detection

GPS is a classic example of the use of wideband DS CDMA that allows of receiving signals of power not exceeding thermal noise power. The experiment was conducted in the measurement system, whose scheme is shown in Fig. 2 (RF1 input switch in the receiver in position B). Processing of received, sampled and recorded signal was implemented with the active block for detection and elimination of narrowband signals. For purposes of this experiment the bandwidth matched to the band of the sought after signal, which in line with the method assumptions should ensure the getting in the middle of the band of analysis the  $P_h$  component that indicates the sought after signal of the DS CDMA GPS system.

The center frequency of the receiver's input circuits working in the receiving set was adjusted at  $f = 1575.42$  MHz. On that carrier frequency by each satellite, the GPS navigation messages are transmitted, which transmission is carried out in two separate DS CDMA channels differing from each other with the bandwidth. The first channel

a) Pow [dB]  
b) Powe [mW]

Fig. 4 result signal



Table 1. The guaranteed values of signals coming from the GPS satellite to the receiving antenna.

Frequency [MHz]	Minimum level of GPS signal [dBm]		Maximum level of GPS signal [dBm]	
	PPS	SPS	PPS	SPS
1575.42	-133	-130	-125	-123

dedicated to a Standard Positioning Service, SPS, is 2.046 MHz band, and the second for a Standard Positioning Service, SPS, band of 20.46 MHz. In both channels the BPSK modulation techniques are used.

Table 1 shows the level of the guaranteed value of the GPS signal coming from a satellite to the receiver antenna (for the topocentric height of a satellite above 5°) [6]. Test signal recording was made at the time when the reception of satellite transmission from ten satellites of the system was possible.

The spectral power density of thermal noise for the system of an impedance of 50 Ω is 174 dBm/Hz. One can assume that taking into account only the thermal noise power for the SPS channel of 2 MHz bandwidth which is 111 dBm the condition of a negative value of the SNR for the executed experiment has been met. The average value of the SNR for the total power of the signals reaching the receiving antenna should theoretically be about -5.5 dB.

During the experiment, there were no narrowband signals in the band of analysis. The power spectral density of the recorded samples and the results obtained by processing and analysis of the 10 000 times averaged PSD of the squared signal (in the time domain) is shown in Fig. 5.

As a result of developed procedures for signal processing the proper identification of the carrier frequency for a GPS signal has been received. The frequency of recommended  $P_h$  component indicated  $f_A = 42.798614$

MHz, which means that in the bandwidth of analysis (IF) the detected signal is located on frequency two times lower, so  $F_d = 21.399307$  MHz. Taking into account the obtained result, for the center frequency of the receiver's input circuits ( $f_{rec} = 1575.420$  MHz) and the value of intermediate frequency ( $f_{IF} = 21.4$  MHz) it can be concluded that the frequency of the detected signal in relation to the channel center frequency of the GPS system has been specified correctly (with the FFT resolution of  $\Delta f_{FFT} = 763$  Hz).

## Conclusions

The conducted experiments have confirmed the effectiveness of signal processing methods developed for the detection of the DC CDMA transmission with BPSK modulation and the power of signal lower than noise power. Using the method for testing the squared signal PSD, it is imperative to carry out the elimination of narrowband signals present in the analysis. Unwanted narrowband signals can disturb the proper operation of the detection algorithms by generating ambiguous and "fake" results.

The process of detection of the DS CDMA signals, whose power is lower than the noise power, is a complex one, and therefore, it should be carried out simultaneously by different methods: correlation, spectral power averaging, and averaging of squared signal PSD.

## Acknowledgements

The scientific work is financed from the funds for science in the years 2010-2012 as a research project.

## References

1. STUDAŃSKI R., WAŚ R., Wykrywanie sygnałów DS SS dla potrzeb morskich systemów analiz radiowych, mat. konferencyjne Krajowa Konferencja Radiokomunikacji Radiofonii i Telewizji, Poznań, p. 360-363, 2006.
2. BUREL G., Detection of Spread Spectrum Transmissions Using Fluctuations of Correlation Estimators, IEEE Int. Symp. on Intelligent Signal Processing and Communication Systems, Hawaii, 2000.
3. STUDAŃSKI R., WAŚ R., Detekcja sygnałów DS CDMA metodą sumowania widma, V Międzynarodowa Konferencja „Perspektywy i Rozwój Systemów Ratownictwa, Bezpieczeństwa i Obronności w XXI wieku”, Gdańsk, 2005.
4. JAŻDŻEWSKI R., Median Filter Application for the Detection of Direct Sequence Spread Spectrum Signals in the Presence of Narrowband Interferences, Regional Conference on Military Communication and Information Systems, Zegrze, 2001.
5. LUC A., VOSICKI V., JANICEK M., Transmission and Detection of DS SS Signal Under Noise, Regional Conference on Military Communication and Information Systems, Zegrze, 2000.
6. SPECHT C., System GPS, Wydawnictwo Bernardinum, Pelplin, 2007.

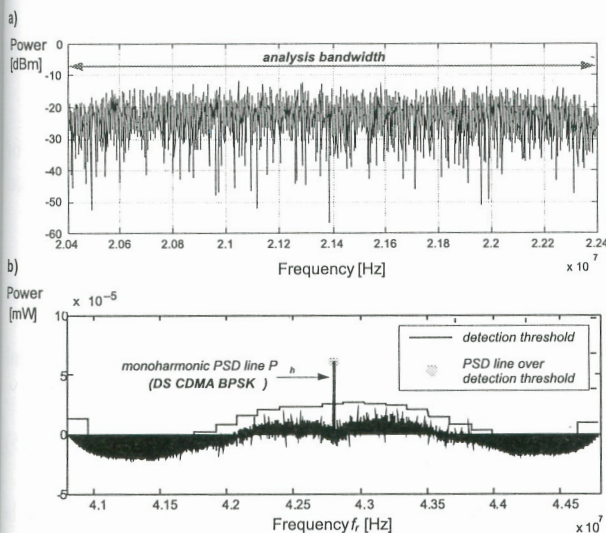

Fig. 5. The signal PSD on the acquisition card input (a) and the result of implementation of procedures for detection of the GPS signal at a frequency  $f = 1500.420$  MHz (b); FFT size:  $N = 2^{17}$ .