



DETERMINATION OF PROBABILITIES DEFINING SAFETY OF A SEA-GOING SHIP DURING PERFORMANCE OF A TRANSPORTATION TASK IN STORMY WEATHER CONDITIONS

Jerzy Girtler

Gdansk University of Technology
Faculty of Ocean Engineering and Ship Technology
Department of Marine and Land Power Plants
G. Narutowicza Str., 80-233 Gdansk
tel.: (+48 58) 347-24-30, e-mail: jgirtl@pg.edu.pl

Abstract

The paper presents the possibility of applying the theory of semi-Markov processes to determine the limiting distribution for the process of changes of technical states being reliability states of the systems of sea-going ships significantly affecting safety of such ships, which include main engine, propeller and steering gear. The distribution concerns the probabilities of occurrence of the said states defined for a long time of ship operation ($t \rightarrow \infty$). The considered states are as follows: s_0 – full ability state of the systems, i.e.: main engine, propeller and steering gear, s_1 – inability state of the main engine, s_2 – inability state of the propeller, s_3 – inability state of the steering gear. Significance of the systems for safety of the ships at sea was demonstrated herein. General conditions for performing transportation tasks by the ships, with particular regard to stormy conditions, were also here described.

Keywords: reliability, semi-Markov process, diesel engine, propeller, sea-going ship, steering gear

1. Introduction

Sea-going ships carry out transportation tasks often in stormy conditions [4, 5, 6, 7, 21]. The conditions are formed by various factors, usually with random properties. First and foremost, the factors include [2, 5, 6, 7, 23]: considerable wave motion through the sea surface at high wind speed, icing of the hull above waterline, water flowing over and through the deck of the ship.

Strong wind is dangerous in particular. Such a wind induces significant aerodynamic forces and moments onto the surface of the ship's hull above waterline. Therefore, there is necessity to compensate the effects of the wind, which requires setting the proper rudder angle. During stormy weather, especially at heavy wave motion and with a propeller partially emerged from water, it may turn out that even the maximum rudder angle is not sufficient to maintain the course of the ship. The ship loses its maneuverability (course stability) and in

consequence is not able to head in a set direction [4, 5, 7]. The course stability is always lost in case of failure of the main engine and/or the propeller. As a result generation of demanded force to maintain the desired course of the ship is impossible. The stability is also lost when the steering gear gets damaged [6]. Flooding the deck creates also a danger to the ship particularly with water violently flowing onto the deck that can damage the ship's superstructure and enter its inside [5, 6, 7]. Another threat to the marine traffic comes from icebergs travelling considerable distances, which sometimes results in collisions with ships [21].

The considerations show that every ship can face different situations. The catastrophic situation is particularly hazardous [8, 11, 14, 18, 21]. It is obvious that the marine scenario is depended on technical condition of the systems that have major influence on the ship safety. Such systems for each ship include main engine, controllable pitch propeller and steering gear [5]. Therefore, the probabilistic model of changes of states of the systems, useful for making rational operational decisions, can be developed basing on the model described in paper [5]. In the ship operational practice, the decisions that can be made are as follows: 1) to commence task performance by the ship; 2) to carry out reconditioning of at least one or simultaneously three of the mentioned systems considered as the ones which substantially contribute to the ship safety, before task performance is commenced by the ship, and 3) not to leave the port until the storm which hazards the ship safety ceases. Making a rational operational decision from among the three options with regard to the statistical decision theory requires to determine the probabilities of damage to the main engine, controllable pitch propeller and steering gear. For this there is a need to develop a model of occurring changes in the technical condition for this sort of ship's systems that may appear while performing a transportation task by the ship, and to recognize the atmospheric conditions in which the task is carried out.

2. Atmospheric conditions during ship cruises

Atmospheric and marine conditions during performance of transportation tasks by ships differ sometimes substantially. In the seasons like spring and autumn in the temperate climate large surface waves are generated by strong winds affecting the surface of sea waters. A scenario of such unfavorable hydrometeorological conditions during performance of a transportation task by a ship is illustrated (as an example) in Fig. 1.



Fig. 1. Scenario of stormy conditions at sea where the container ship performs a transportation task (situation considered at least as dangerous) [4]

Strong wind (wind of high velocity w_w) severely affects the ship's hull with forces being produced while putting pressure onto the upper part of the hull, while large sea waves strongly act on the underwater part of the hull. This wind in gusts can have velocity $w_w = 24,4$ m/s (severe gale, strength of the wind ranked 9 on the Beaufort scale), $w_w = 28,4$ m/s (storm, strength of the wind ranked 10 on the Beaufort scale) $w_w = 32,5$ m/s (violent storm, strength of the wind ranked 11 on the Beaufort scale) and even $w_w = 36,6$ m/s (hurricane, strength of the wind ranked 12 on the Beaufort scale). Additionally, sea waves can reach over 10m at the wind ranked 10 on the Beaufort scale [12]. Then the high water mountains are formed, and the entire surface of the sea becomes white due to abundant foam of braking white wave crests and the sea roars. This situation jeopardizes the safety of the ship and often leads to sinking of it even when the propulsion system and the steering gear are not damaged. As a rule, a ship sinks when damage occurs to the components of the main propulsion system like main engine and propeller. Failure of the engine (1) or propeller (7) means in fact failure of the propulsion system of the ship. In consequence, the thrust force T (Fig. 2) cannot be produced. No thrust force (T) causes lack of a driving force (T_N) that balances the resistance (R_x) and puts the ship into motion at velocity v (Figure 2). The force T_N along with the force acting on the rudder ensure the required course stability (control) for the ship. This means that the steering gear must not get damaged as well (Fig. 3).

The R_{ha} and R_{G1} forces acting on the arm a (Fig. 2) cause that the ship is trimmed by the stern, which is further increased by T_N and R_x forces acting on the arm b . Consequently, the driving force (T_N) is reduced significantly. This deteriorates remarkably stability of the ship's course and thus the safety of the ship.

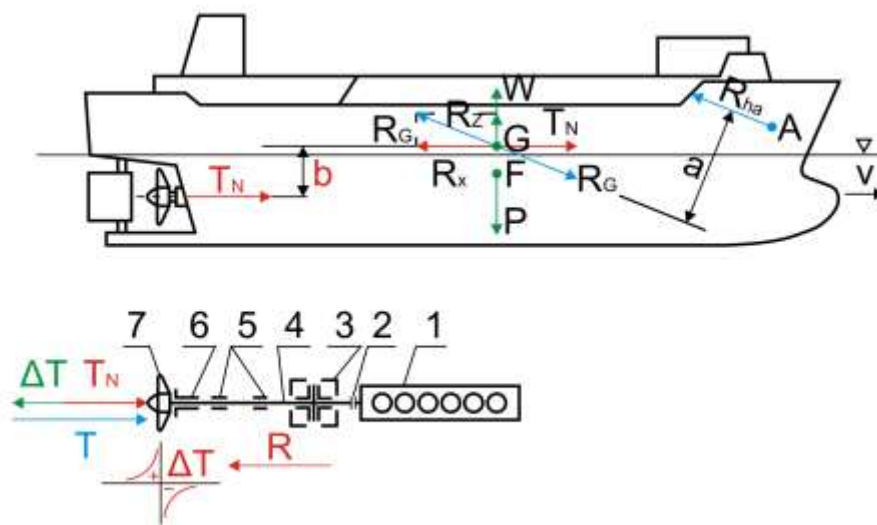

Fig.2. Forces and moments acting on a ship: T – thrust force, T_N – driving force, ΔT – thrust deduction, $R = R_x$ – overall ship hull resistance which is balanced by force T_N , R_{ha} – resultant force of all hydrodynamic and aerodynamic forces acting on the ship, P – ship weight, W – ship's buoyancy force, G – ship's center of gravity, F – ship's center of buoyancy, a – arm being acted by the forces R_{ha} and R_{G1} , b – arm being acted by forces T_N and R_x which generate the moment, 1 – main engine, 2 – coupling, 3 – thrust bearing with (thrust) shaft, 4 – propeller shaft, 5 – radial bearings, 6 – stuffing-box, 7 – propeller [4]

In case of failure of a main engine or propeller, or of a steering gear, each ship in stormy seas usually ends in catastrophe. Even partial damage to the main engine or propeller makes it impossible to generate the force T (Fig. 2) necessary to drive the ship. In such events the rudder angle (Fig.3), even at the maximum, is not sufficient to produce enough force to

compensate the effect of the wind and waves. As a result, each ship loses at the beginning its maneuverability (course stability) and is incapable of moving in the set direction, and then loses stability. Along with appearance of upwind and the following wave in the conditions of high wave motion, usually it comes to capsizing [11].

Course stability is possible to be maintained by the ship when its main engine is capable of being loaded in the full range to which it was designed and manufactured [9, 13] and during the cruise no damage to the propeller and steering gear is found. An exemplary diagram of an electro-hydraulic steering gear with feedback is shown in Fig. 3. Failure of any of its components, particularly the positive displacement multi-piston pump (8), the electric motor (6), the actuator of a steering gear consisting of a plunger (10) and cylinder (16), as well as failure of the telemotor transmitter (3), the telemotor receiver (5) or loss of the rudder (9), mean a damage to the steering gear.

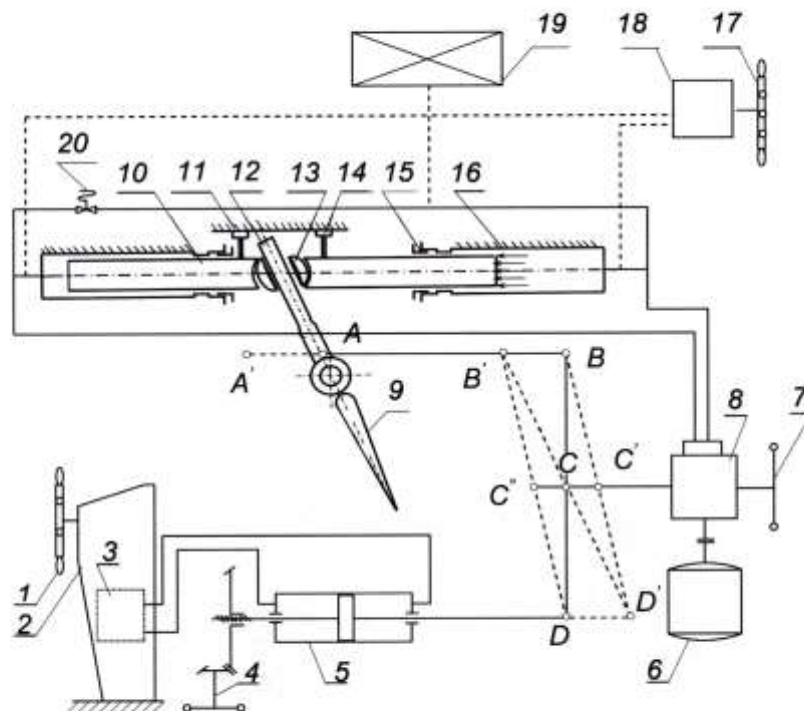

Fig. 3. Diagram of an electro-hydraulic steering gear with feedback:

- 1 – steering wheel, 2 – steering column, 3 – telemotor transmitter, 4 – emergency steering wheel, 5 – telemotor receiver, 6 – electric drive motor, 7 – emergency steering wheel, 8 – variable displacement piston pump, 9 – rudder, 10 – plunger, 11 – guide; 12 – tiller, 13 – joint, 14 – slide, 15 – gland, 16 – cylinder, 17 – emergency steering wheel, 18 – displacement radial multi-piston pump [6]

Failure of the components of the main propulsion system such as main engine and propeller as well as of the steering system during a cruise is hardly possible if the probabilities of their proper operation are high. Estimation of the probabilities requires developing a model of changes of technical states as reliability states for such ship's systems.

3. Model of changes of reliability states for the systems of fundamental importance for the ship safety

This model assumes that the systems of fundamental importance for the ship safety include main engine, propeller and steering gear, because they get damaged the most often [6]. All the

systems may break down during their operation. Usually they can be reconditioned (of course, if it is cost-effective) by providing appropriate service.

For the systems, as well as for other shipborne equipment, the model for the process of changes of their reliability states can be considered as semi-Markov process $\{W(t): t \geq 0\}$ with set $S = s_i; i = 0, 1, 2, 3$ [5]. States $s_i \in S (i = 0, 1, 2, 3)$ are interpreted as follows: s_0 – state of full ability of the all considered systems (main engine, propeller and steering gear), s_1 – inability state of the main engine, s_2 – inability state of the propeller, s_3 – inability state of the steering gear. Changes of states $s_i (i = 0, 1, 2, 3)$ proceed at successive moments $t_n (n \in N)$, where at moment $t_0 = 0$ all the mentioned systems are in state s_0 . The state s_0 continues until any of the systems gets damaged. States $s_i (i = 1, 2, 3)$ last as long as one of the systems is reconditioned or replaced with another when reconditioning is unprofitable. Transition from state s_i to states $s_j (i, j = 0, 1, 2, 3; i \neq j)$ proceeds after lapse of time T_{ij} , which is a random variable with a non-exponential distribution [4, 9, 12, 13, 20, 22]. Consideration of this situation in the ship's operation phase requires probabilistic description of the ship operation process with regard to probabilities of occurrence of the mentioned possible states $s_i (i = 0, 1, 2, 3)$ at the particular moments t_0, t_1, \dots, t_{n-1} , of the ship operation time t_n [1, 2, 3, 17, 19, 24].

It can be assumed that states of the considered systems at time t_{n+1} and the time interval of duration of the state gained at the moment t_n do not depend on states that occurred at earlier moments t_0, t_1, \dots, t_{n-1} , nor the time intervals of their duration. Thus, the process $\{W(t): t \geq 0\}$ can be assumed to be a semi-Markov process [7, 9, 10, 12, 13]. For that reason, a four-state model for the process of changes of states $s_i (i = 0, 1, 2, 3)$ classified to set S (i.e. $s_i \in S, i = 0, 1, 2, 3$) can be applied just like in paper [15].

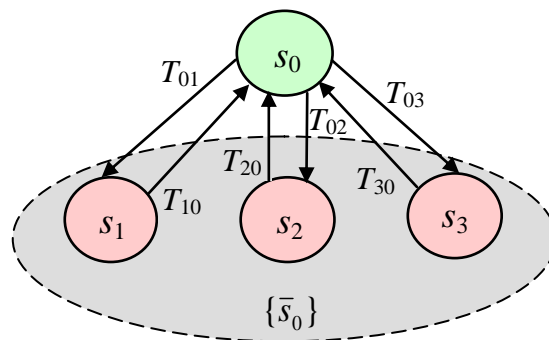

Fig. 4. Graph of changes of states for the process $\{W(t): t \in T\}$: s_0 – ability state of the systems, $\{\bar{s}_0\}$ – set of inability states of the systems (engine, propeller and steering gear): $\{\bar{s}_0\} = \{s_1, s_2, s_3\}$, $s_i \in S (i = 1, 2, 3)$ – states with the following interpretation: s_0 – state of full ability of the all considered systems (main engine, propeller and steering gear), s_1 – inability state of the main engine, s_2 – inability state of the propeller, s_3 – inability state of the steering gear, T_{ij} – duration of state s_i provided that the next state is $s_j (i, j = 0, 1, 2, 3; i \neq j)$

The initial distribution of the process is as follows:

$$P\{W(0) = s_i\} = \begin{cases} 1 & \text{dla } i = 0 \\ 0 & \text{dla } i = 1, 2, 3 \end{cases} \quad (1)$$

and the matrix function takes the form:



$$\mathbf{Q}(t) = \begin{bmatrix} 0 & Q_{01}(t) & Q_{02}(t) & Q_{03}(t) \\ Q_{10}(t) & 0 & 0 & 0 \\ Q_{20}(t) & 0 & 0 & 0 \\ Q_{30}(t) & 0 & 0 & 0 \end{bmatrix} \quad (2)$$

A graph of changes of states for the process, as it results from the matrix (2), is demonstrated in Fig. 4.

An exemplary realization of the process $\{W(t): t \geq 0\}$ reflecting occurrence of reliability states of the said systems under operation, in accordance with the matrix function (2), and hence with the graph (fig 4), is depicted in Fig 5.

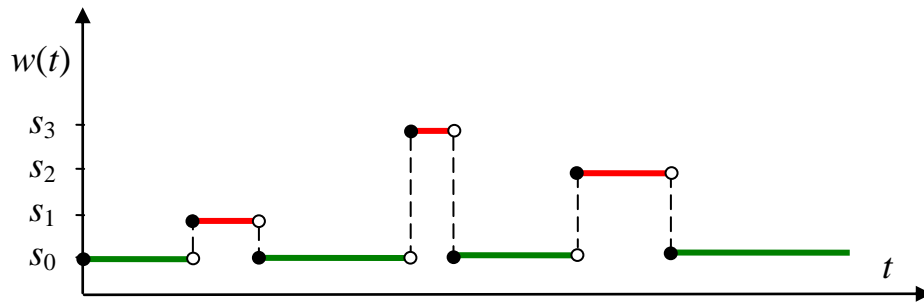

Fig. 5. Exemplary realization of the process $\{W(t): t \geq 0\}$ for the considered systems: s_0 – ability state of the all considered systems, s_1 – inability state of the main engine, s_2 – inability state of the propeller, s_3 – inability state of the steering gear

Matrix function $\mathbf{Q}(t)$ is a model of changes of reliability states for the considered (previously mentioned) systems. Non-zero elements $Q_{ij}(t)$ of the matrix $Q(t)$ depend on distributions of the random variables that are time intervals of staying the process $\{W(t): t \geq 0\}$ in states $s_i \in S (i = 0, 1, 2, 3)$. The elements of the matrix function $\mathbf{Q}(t)$ are probabilities of the process transition from s_i to $s_j (s_i, s_j \in S)$ in time no longer than t , being defined as follows:

$$Q_{ij}(t) = P\{W(\tau_{n+1}) = s_j, \tau_{n+1} - \tau_n < t | W(\tau_n) = s_i\} = p_{ij}F_{ij}(t) \quad (3)$$

where:

p_{ij} – probability of one-step transition in the homogeneous Markov chain embedded in the process $\{W(t): t \geq 0\}$; $p_{ij} = P\{W(\tau_{n+1}) = s_j | W(\tau_n) = s_i = \lim_{t \rightarrow \infty} Q_{ij}(t)\}$;

$F_{ij}(t)$ – distribution function of the random variable T_{ij} denoting duration of state s_i in the process $\{W(t): t \geq 0\}$ provided that the next state in the process is s_j .

The matrix \mathbf{P} of probabilities of transition in the Markov chain embedded in the process, as it results from the matrix function $\mathbf{Q}(t)$ (2), is as follows [5, 7, 9]:

$$\mathbf{P} = \begin{bmatrix} 0 & p_{01} & p_{02} & p_{03} \\ 1 & 0 & 0 & 0 \\ 1 & 0 & 0 & 0 \\ 1 & 0 & 0 & 0 \end{bmatrix} \quad (4)$$

In the process $\{W(t): t \geq 0\}$ the random variables T_{ij} have finite and positive expected values. Consequently, its limiting distribution [6, 7, 9, 16]

$$P_j = \lim_{t \rightarrow \infty} P_{ij}(t) = \lim_{t \rightarrow \infty} P\{W(t) = s_j\}, s_j \in S(j = 0, 1, 2, 3) \quad (5)$$

is of the following form:

$$P_j = \frac{\pi_j E(T_j)}{\sum_{k=0}^3 \pi_k E(T_k)} \quad (6)$$

Probabilities $\pi_j(j = 0, 1, 2, 3)$ in formula (6) are limiting probabilities of the Markov chain embedded in the process $\{W(t): t \geq 0\}$. $E(T_j)$ and $E(T_k)$ are expected values of the random variables T_j and T_k , respectively which denote the time of staying of each system in state s_j and s_k respectively, regardless of which state is later.

Derivation of the limiting distribution (6) requires solving the system of equations (7) which include limiting probabilities $\pi_j(j = 0, 1, \dots, 10)$ of the embedded Markov chain and the matrix \mathbf{P} of probabilities of transition from state s_i to state s_j defined by the formula (4), i.e. the system of equations like:

$$\left. \begin{aligned} [\pi_0, \pi_1, \pi_2, \pi_3] &= [\pi_0 \ \pi_1, \pi_2, \pi_3] \cdot \mathbf{P} \\ \sum_{k=1}^4 \pi_k &= 1 \end{aligned} \right\} (7)$$

As a result of solving the system of equations (7) by using formula (6) the following relationships can be derived:

$$\left. \begin{aligned} P_0 &= \frac{E(T_0)}{E(T_0) + \sum_{k=1}^3 p_{0k} E(T_k)}, P_1 = \frac{p_{01} E(T_1)}{E(T_0) + \sum_{k=1}^3 p_{0k} E(T_k)}, P_2 = \frac{p_{02} E(T_2)}{E(T_0) + \sum_{k=1}^3 p_{0k} E(T_k)}, \\ P_3 &= \frac{p_{03} E(T_3)}{E(T_0) + \sum_{k=1}^3 p_{0k} E(T_k)}. \end{aligned} \right\} (8)$$

Probability P_0 is a limiting probability of occurrence of the event that in a long time of operation (theoretically at $t \rightarrow \infty$) the considered systems (main engine, propeller, steering gear) will stay in state s_0 . Thus, the probability defines the status of their technical readiness. Probabilities $P_j(j = 1, 2, 3)$ are limiting probabilities of occurrence of states $s_j \in S(j = 1, 2, 3)$ of the systems at $t \rightarrow \infty$ which denote their stay in inability states.

Obtaining (of course, in approximation) the values of probabilities $P_j(j = 0, 1, 2, 3)$ requires estimation of probabilities p_{ij} and expected values $E(T_j)$.

Estimation of the probabilities p_{ij} and the expected values $E(T_j)$ is possible after obtaining realization $w(t)$ of the process $\{W(t): t \in 0\}$ in a sufficiently long time of examination, so for $t \in [0, t_b]$, where the time of examination of the process is $t_b \gg 0$. It is possible then to determine the values $n_{ij}(i, j = 0, 1, 2, 3; i \neq j)$, and transitions of the process $\{W(t): t \in 0\}$ from

s_i to s_j in a sufficiently long time as well as to determine the values of the estimator \hat{P}_{ij} of the unknown probability p_{ij} . The estimator of the highest reliability of the probability of transition p_{ij} is the statistics [9, 16]:

$$\hat{P}_{ij} = \frac{N_{ij}}{\sum_j N_{ij}}, \quad i \neq j; \quad i, j = 0, 1, 2, 3, \quad (9)$$

whose value $\hat{p}_{ij} = \frac{n_{ij}}{\sum_j n_{ij}}$ is the estimation of the unknown probability of transition p_{ij} .

From the above mentioned realization $w(t)$ of the process $W(t)$ there can be obtained realizations $t_j^{(m)}$, $m = 1, 2, \dots, n_{ij}$ of the random variables T_j . Application of the point estimation allows easy estimation of $E(T_j)$ as the arithmetic average of $t_j^{(m)}$. To obtain the necessary information for estimation of the probabilities it is necessary to apply diagnostic systems (SDG) adequate for the mentioned systems which hence are diagnosed systems (SDN) [9, 13].

4. Remarks and conclusions

The paper describes the limiting distribution of the process $\{W(t): t \geq 0\}$ representing the probabilities of occurrence of states: s_0 – ability state of the all considered systems (main engine, propeller and steering gear), s_1 – inability state of the main engine, s_2 – inability state of the propeller, s_3 – inability state of the steering gear. The probabilities were recognized indispensable while making rational decisions in the phase of ship's operation, especially in terms of ship safety.

Usability of the mentioned probabilities for making rational decisions with regard to safety of the ship's systems was presented in papers [5, 6, 8] which provide description of the rule of making an optimum decision by considering the expected value of consequences of the made decisions as the criterion function.

The theory of semi-Markov processes can be applied to determine the said probabilities.

Application of the semi-Markov process as a model of changes of the mentioned reliability states for the process $\{W(t): t \geq 0\}$, instead of the Markov process, results from that the random variables T_{ij} and T_i can be supposed to have arbitrary distributions, other than exponential, concentrated in set $R_+ = [0, +\infty)$.

The model of the real process of changes of the considered herein reliability states shown in the form of the semi-Markov process $\{W(t): t \geq 0\}$ can be of practical significance due to ease of estimation of both: the probabilities of transition p_{ij} and the expected values $E(T_j)$. It should be taken into account that the point estimation of the expected value $E(T_j)$ does not allow to determine accuracy of its estimation. Such accuracy is possible with interval estimation where a confidence interval is derived with random limits, lower t_{dj} and upper t_{gj} that with certain probability (confidence level) β contains the unknown expected value $E(T_j)$.

References

- [1] Benjamin J. R., Cornell C. A.: *Probability calculus, mathematical statistics and decision theory for engineers*. WNT, Warszawa 1977.

- [2] Firkowicz S.: *Statistical assessment of quality and reliability of electronic lamp*. WNT, Warszawa 1963.
- [3] Gercbach I.B., Kordonski Ch.B.: *Reliability models of technical objects*. WNT, Warszawa 1968.
- [4] Girtler J.: *The semi-Markov model of the process of appearance of sea-going ship propulsion system ability and inability states in application to determining the reliability of these systems*. Polish Maritime Research 4(80) 2013 Vol 20; pp. 18-24.
- [5] Girtler J.: *Issue of making decisions with regard to ship traffic safety in different situations at sea. . W: Marine Navigation and Safety of Sea Transportation Navigational Problems*. 2013, Gdynia pp.63 – 70 (chapter in Monograph).
- [6] Girtler J., Kuzmider S., Plewiński L.: *Selected issues of operation of sea-going ships in the aspect of navigation safety*. Monograph. WSM, Szczecin 2003.
- [7] Girtler J., Kitowski Z., Kuriata A.: *Ship safety at sea. System approach*. WKiŁ, Warszawa 1995.
- [8] Girtler J.: *Application of the Bayesian decision theory for controlling the machine operation process*. Materials of XXII Winter Reliability Academy on Reliability evaluation in the processes of technological tasks performance, in logistic approach. SPE KBM PAN, Szczyrk 1994, s.55-62.
- [9] Girtler J.: *Control over the process of ship combustion engine operation on the basis of decision – making diagnostic model*. Journals of AMW, Nr 100A, Gdynia 1989.
- [10] Girtler J.: *Probability as a measure of operational safety of technical objects*. Materials of 7th Scientific Conference „Safety of systems”. PTBiN, PTC, SPE KBM PAN, STST KT PAN, Transport Departament of PW, ITWL, Warszawa-Zakopane-Kościelisko 1998, pp.163-168.
- [11] Girtler J.: *Suggestion of interpretation of action and the rule of taking decision with regard to safety of sea ships traffic*. Machine Operation Aspects. Z. 2(122), vol. 35, 2000, pp177-191.
- [12] Girtler J.: *A concept of decision-making process with taking into account reliability and safety of sea transport means*. Materials of Domestic Conference on Safety and Reliability, Vol.1. ITWL, Warszawa-Zakopane-Koscielisko 1999, pp. 289-296.
- [13] Girtler J.: *Diagnostics as a condition for control over ship combustion engines in operation*. Studies No. 28. WSM, Szczecin 1997.
- [14] Girtler J.: *Availability of sea transport means*. Archives of Transport. Polish Academy of Sciences Committee of Transport. Quarterly, vol. 9, iss. 3-4, Warszawa 1997.
- [15] Girtler J.: *Features of load and wear of main propulsion devices on sea-going ships with piston combustion engines and their impact on changes in technical states of the systems*. Polish Maritime Research 4(96) 2017 Vol 24 (accepted for publishing).
- [16] Grabski F.: *Theory of semi-Markov processes of operation of technical objects*. Journal of WSMW, No. 75A, Gdynia, 1982.
- [17] Gniedenko B.W., Bielajew J.K., Sołowiew A.D.: *Mathematical methods in theory of reliability*, WNT, Warszawa,1968.
- [18] Jąźwiński J., Borgoń J.: *Operational reliaility and flight safety*. WKiŁ, Warszawa 1989.
- [19] Krzysztofiak M., Urbanek D.: *Statistical methods*. PWN, Warszawa 1979.
- [20] Łosiewicz Z.: *Identifying the issue of reducing the emission of harmful compounds in the exhaust gas from marine main engines and description of the emission process of these compounds in probabilistic approach*. Polish Maritime Research No. 2(94) 2017, Vol. 24, pp. 89-95.
- [21] Plewiński L.: *Accidents at sea. Collisions of ships*. Publ. of WSM, Szczecin, 2000.



- [22] Rudnicki J.: *Application issues of the semi-Markov reliability model*. Polish Maritime Research No. 1(85) 2015, Vol. 22, pp. 55-64.
- [23] Wiśniewski B.: *Wind waves*. Treatises and studies t. (CCCIV) 230. University of Szczecin, Szczecin 1998.
- [24] *Guidebook on reliability*. Collective work edited by J. Migdalskiego. Machine Industry Publishing House „WEMA”, Warszawa 1982.