

# Development of Intelligent Road Signs with V2X Interface for Adaptive Traffic Controlling

Andrzej Czyżewski  
Multimedia Systems Department  
Faculty of Electronics, Telecommunications and Informatics  
Gdansk University of Technology  
Gdansk, Poland  
[inznak@multimed.org](mailto:inznak@multimed.org)

A. Sroczyński, T. Śmiałkowski  
SILED Sp. z o.o.  
[andrzej.sroczynski@siled.pl](mailto:andrzej.sroczynski@siled.pl)  
[tomasz.smialkowski@siled.pl](mailto:tomasz.smialkowski@siled.pl)

Piotr Hoffmann  
MICROSYSTEM Sp. z o.o.  
[p.hoffmann@microsystem.com.pl](mailto:p.hoffmann@microsystem.com.pl)

**Abstract** – The objective of this paper is to present a practical project of intelligent road signs, under which a series of new products for the regulation of traffic is being created. The engineering part of the project, described in this paper, was preceded by a series of experimental studies, the results of which were described in another paper accepted for publication at the MTS-ITS conference 2019, entitled "Comparative study on the effectiveness of various types road traffic detectors". A new kind of intelligent road signs which will enable the prevention of the most common collisions on highways, resulting from the rapid stacking of vehicles resulting most often from accidental heavy braking. A range of products is being developed, including intelligent road signs: standing, hanging and mobile ones, displaying dynamically updated driving the speed limit, determined automatically, through an embedded electronic module, enabling multimodal measurement of traffic conditions. Solving a number of research and construction problems, such as: effective and independent of weather conditions traffic monitoring based on simultaneous analysis of several types of data representation, development of a method of calculating gradients and histograms of vehicle speed for various types of road situations or traffic topologies. Moreover, creating a platform for self-organizing reliable wireless connections among road signs equipped with innovative displays and power supplies and carrying out prototype tests are carried out. As a result, advanced conceptually products for increasing road safety for which there is a market demand are being prepared for future implementation.

**Keywords** – road signs; traffic analysis; signal processing; renewable electricity; wireless data transmission; Vehicle-to-everything

## I. INTRODUCTION – THE PROJECT INZNAK

The INZNAK project entitled "Intelligent Road Signs with V2X Interface for Adaptive Traffic Controlling" is carried out in response to the demand for improving road safety and traffic efficiency. The project has the purpose of improving traffic efficiency and safety by developing and constructing a network of autonomous road signs. Using intelligent road signs for the traffic control will allow for avoiding the most common collisions on motorways, which results from not adjusting the speed to existing weather conditions and to the physical condition of the road, as well as from the accumulation of cars in case there is a need of emergency braking.

During the development of the project, 3 types of road signs are designed and engineered: standing, hanging and mobile. Each of the signs will have a display showing info & guidelines for the drivers and the suggested speed. The tips will be displayed in the form of text messages and images, which will warn or inform about current traffic problems. By using a series of signs placed along the road, the drivers will be warned much more quickly about potential dangers on the road than in the case of non-autonomous road signs. This is due to the fact that every sign will be communicated with others, which will make traffic management faster. The signs are interconnected in the LoRaWAN and LTE technology. The LoRaWAN technology allows the road signs to communicate with one another. The LTE technology will be used for sending and receiving messages from the traffic administration center. Using the two-level communication will help prevent the effects of potential failures of the telecommunication infrastructure.

In order to secure the supply of current information to the autonomous signs, it is necessary to provide them with a number of sensors, which would constantly analyze the traffic flow in the road sign's surroundings. Experimental installations of intelligent signs will have sensors analyzing road traffic, such as Doppler radar, lidar, acoustic probe, RGB camera, and Bluetooth receiver. Because of the fact, that risk on the road results changing weather conditions, such as thunderstorms, blizzards, fogs, black ice, every sign will have a weather station installed, thus it will be able to analyze current weather conditions in the surroundings of the sign. By that, the resolution of the weather forecast will be very high. The proposed approach towards the traffic analysis is based on the principles of multimedia technology, and therefore it is possible to complement each of the individual methods just where it will better fulfill its function. Such a case can be observed e.g. at night, where standard cameras record mainly the lights of the cars. Using a microwave radar, lidar or an acoustic sensor in such circumstances will allow for correct detection of the majority of cars.

The project is still in progress at the time this paper is written. The current stage of its advancement is shown in 2 papers prepared for the MT-ITS 2019 conference, namely in this paper and in the paper entitled "Comparative study on the effectiveness of various types of road traffic intensity detectors". While this second paper discusses and compares vehicle detection and speed measurements, in this paper, we

concentrate on solutions applied to exchange data and to supplying of electricity necessary to power devices outside urban areas. Moreover, we present the concept of an embedded device for testing the condition of a road surface depending on weather conditions.

## II. DATA EXCHANGE MECHANISMS

The concept of mechanisms for communicating road signs with each other employing transmission standards has been developed, along with a description of the methodology of using the solution as a terminal for the vehicle communication with road infrastructure (V2I). The distributed and scalable construction of the intelligent road sign system requires the development of communication mechanisms on 3 layers:

- Data exchange for the INZNAK Management Center <-> group of road signs
- Data exchange road sign <-> road sign
- V2X data exchange (road sign <-> vehicle)

The developed concept assumes the possibility of communicating road signs with each other in order to disseminate information about a potentially dangerous situation at a distance. Communication will be carried out through the central server, assuming simultaneous maintenance of connections between individual road signs. The block diagram illustrating principles of communication in the system has been presented in Fig. 1. It consists of two main parts: the road sign and a management center. Intelligent road signs are designed to create a mesh information exchange network, thanks to which they will react autonomously to changing road conditions. The signs within a given group will communicate via a network operating in the LoRaWAN (Long Range Wide-Area Network) standard. The representative of the group of road signs will communicate with the second essential element of the system, i.e. with the management center, via a wireless network in the LTE standard. The third planned to use communication standard in the system is V2X - Vehicle-to-Everything, which will be used to retrieve messages regarding current traffic from both road infrastructure and passing vehicles. Under this system, road signs must exchange information about sensor-derived data and refer to decisions made. It is assumed that each road sign integrated with the system has access to all data sent by other signs in the system. Internal device systems must also be able to communicate with the server. Despite the assumed autonomy, the solutions of the intelligent signs group require supervision by the system operator, who will constantly monitor the correctness of the displayed content, as well as be able to impose content intended for display. This approach is necessary to ensure credibility and compliance with legal regulations.

Data in sign-server communication due to the extensive arrangement of individual groups of signs will have to be sent over long distances. Any sign or group of signs (depending on the chosen configuration) will have to establish a connection

with the Management Center. Data transmission over a distance of more than 20 km entails the necessity of GSM network usage. The amount of data transferred in the system should not be more than 100 kb/s, therefore the 3G network is quite sufficient to send system messages, and the solution fits well in the network development strategy and also in new operator tariff plans related to the IoT (Internet of Things). The coverage of the 3G territory of the Polish territory is practically full, therefore the disruption of the nature of the coverage should not occur. Communication sign/group of signs <-> Management Center can be used to send information in both directions. In the case of data transfer from Management Center towards road signs, the transmitted information may concern control information from the system operator in order to force the display of specific content on the signs, e.g. speed limit or narrowing of the road. In addition, information can also be sent to signs about the current conditions on the road from online databases (weather, current traffic). The data stream coming from the roads sign to the Management Center contains information on the current content that is displayed on the signs and the decisions which the standalone signs make so that the system operator can monitor or correct them.

An important feature of the intelligent road sign is the functionality of communication with vehicles that are equipped with V2X systems. It is planned to receive information sent by vehicles in the form of V2I messages (Vehicle to Infrastructure) and broadcast messages towards vehicles. The information collected by vehicle measurement systems will be an important complement to the data on the current state of traffic on the test section of the road. Fig. 2 presents a communication diagram of road signs with vehicles. Due to the limited number of vehicles with V2X interfaces, it is planned to prepare two types of messages transmitted by the infrastructure to vehicles, namely I2V and VIS. I2V messages which will be transmitted to road users equipped with V2X terminals, using standard content, e.g. DENM. In turn, VIS messages will be transmitted to road users who do not have V2X systems, by providing content in a visual form on the sign display, only.

## III. EXPERIMENTAL ROAD SIGN DESIGN

The design developed at this stage is intentionally redundant because it currently serves research purposes. In particular, the measurement of road traffic intensity is carried out simultaneously with the help of many sensors, whose operation is based on different physical principles (electromagnetism: microwave radar, optics: laser sensors plus video camera and ToF camera, acoustics: microphone and the developed intensity probe and accelerometer).

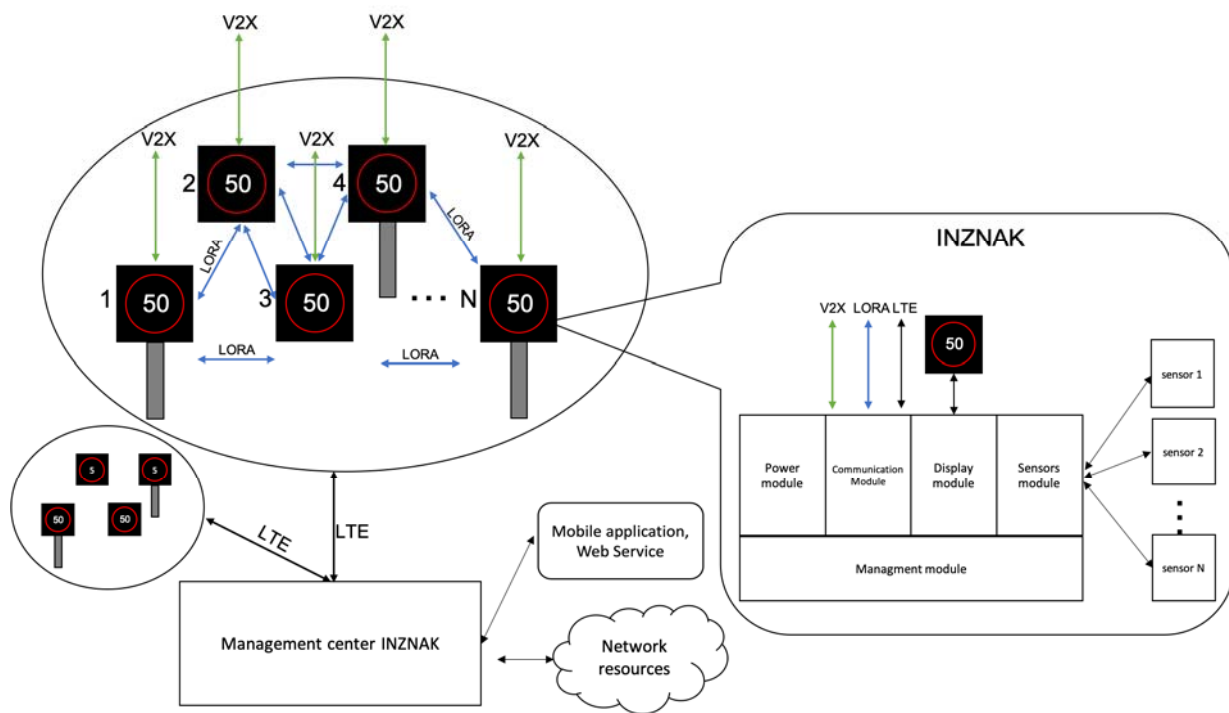

Fig. 1 Block diagram of the communication system

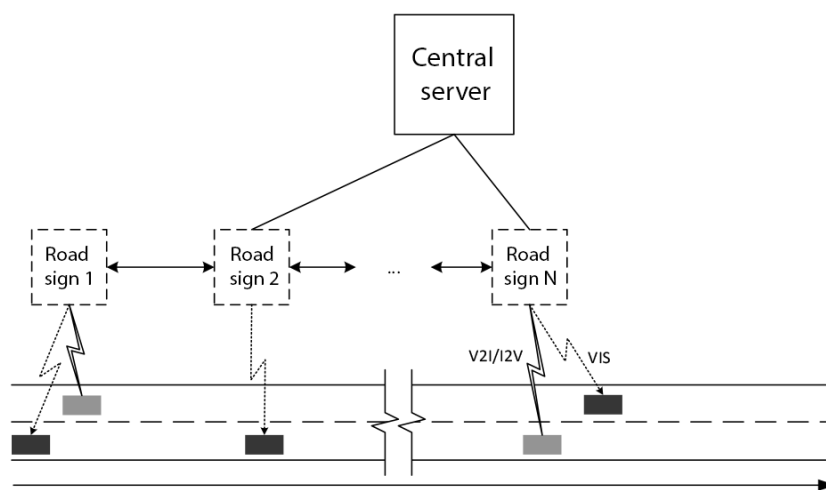

Fig. 2 Diagram illustrating communication of road signs with vehicles

The main element of the architecture is a microcomputer, whose role is to control the operation of the intelligent road sign, acquire data from sensors, to perform data analysis and maintain communication with other elements of the system. The other sensors and circuits are connected to the microcomputer using USB and Ethernet ports. The microcomputer has a supervisory role that manages the entire road sign environment. The complete road consists also of the following modules: sensors, radar, vision, display, communication, power supply (see Fig. 3). Some concepts

underlying the design are protected by industrial property rights [1-4]. The use of a multi-module construction of the road sign allows for an effective and independent from weather conditions traffic monitoring, made on the basis of simultaneous analysis of several types of data representation. The development of individual modules was preceded by project work on the development of new methods and algorithms for obtaining and processing information, which are documented in in publications [6-10][11]. For example, the method of processing data from low-cost microwave sensors has been optimized by eliminating noise and

reflections [7]. Another example of the effects obtained is an article published in the scientific acoustic journal [9] on how to calibrate an acoustic probe for vehicle tracking on an acoustic basis. This material has also entered the scope of the paper presented at the global acoustic congress (Acoustical Society of America, Victoria, Canada) [11].

The sensor module is the main block in which the traffic condition is analyzed. The central element of the module is a microcomputer that processes signals received from the sensors and transmits the conclusions from the received signals to the central control unit. Sensors that collect information on traffic and environmental conditions are connected. At present, the following environmental sensors are tested: light intensity sensors, humidity, temperature. The main functionality of these sensors is to provide weather information. Thanks to the information provided, the road sign is able to record current weather information from the place where it is located. This is particularly important for situations where there are weather phenomena limited to small areas, such as heavy rainfall, black ice or fog.

The radar module is an element that is responsible for real-time analysis of traffic in the immediate vicinity of the sign.

During the design work it was determined that three types of radar using Doppler technology, lidar and acoustic were analyzed. Experiments conducted so far in the stage indicate greater universality of application for Doppler technology. Tests and simultaneous comparisons of all technologies will be the subject of further research in this phase, whereas in this paper individual technologies are tested with a comparison to ground truth data.

The vision module is the next after the radar module in which the current traffic in the vicinity of the sign is analyzed [8], [10]. Currently, a miniature video camera has been used to record a color image in visible light. The camera has been connected to an advanced GPU that processes the image in real time. Continuous observation and processing of signals from radar and cameras allow for immediate detection.

Detailed descriptions of the developed concepts were discussed at conferences in the field of information and communication technologies [7][8] and of road engineering [6].

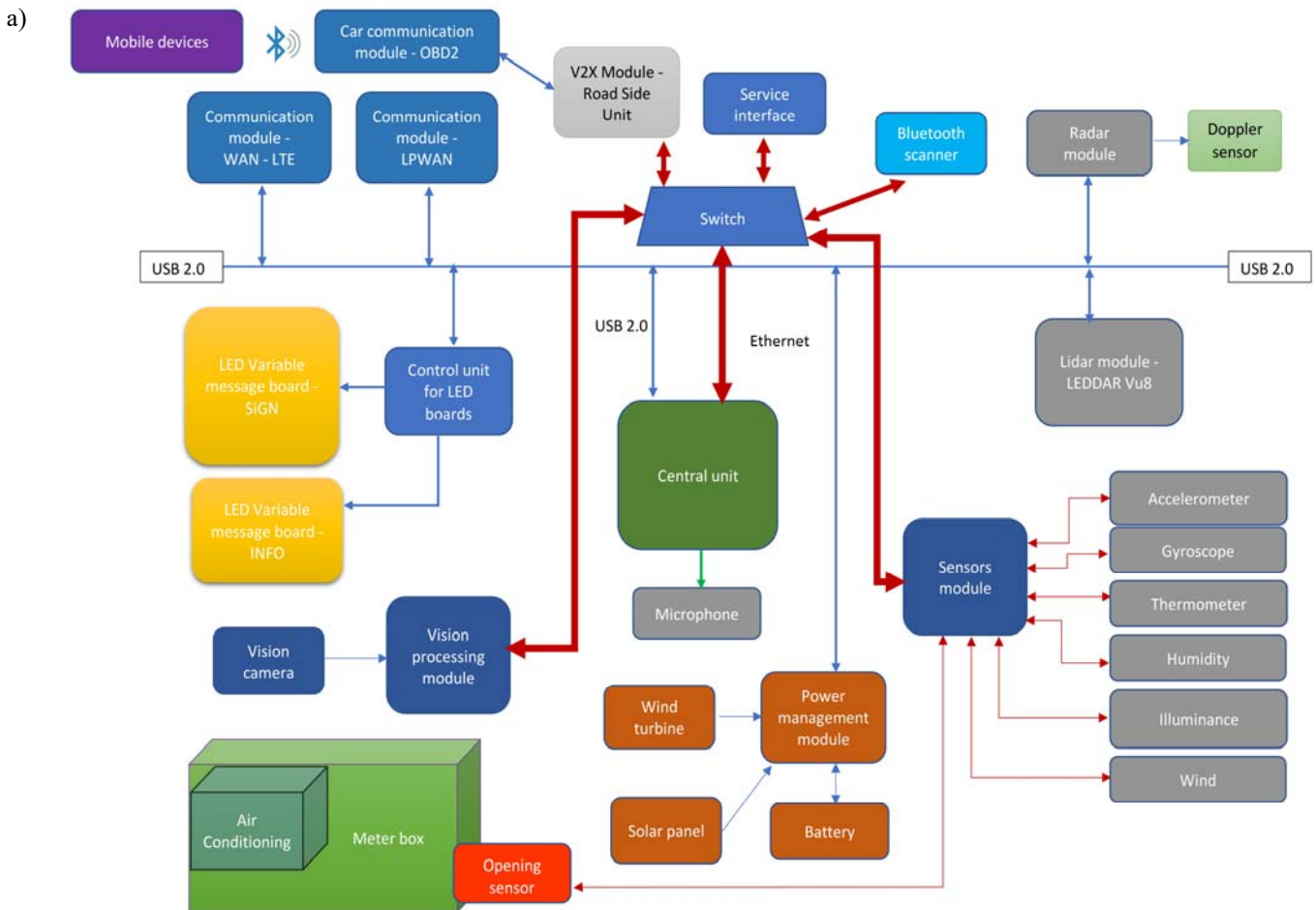





Fig. 3 Block diagram (a), experimental installations for comparative tests of laser, optical and acoustic sensors (b), effects of image processing from a video camera by a deeply trained neural network (c), hardware implementation of an integrated experimental laboratory stand (d)

#### IV. POWER SUPPLY SYSTEM

The intelligent road sign should be able to operate in the off-grid power supply system, especially if it is installed along roads far from built-up areas. For the needs of power systems utility tests, a built-in stand was designed to test the real possibilities of obtaining energy from selected energy sources. Currently tested in the laboratory power supply technologies are:

- Photovoltaic batteries
- Wind generators

The main goal of the experiments was to check the possibility of obtaining power autonomy for an intelligent road sign. Both photovoltaic batteries and wind generators are characterized by high variability of energy production depending on unpredictable environmental conditions. During favorable conditions - high insolation, strong wind - these sources must be able to supply energy far exceeding the instantaneous demand so that the excess energy can be stored in the battery. The demand for energy is also variable. The luminance of the road sign, and thus the energy consumed, will depend on the weather conditions and the level of sunshine. In order to analyze the possible broad spectrum of energy demand scenarios, a stand was constructed. The stand was created at

the SILED contractor's company and it consists of the main elements:

- Wind turbine
- Solar panel
- Positioning system
- Artificial load
- Measuring transducers
- Data Recorder

The block diagram of the built station is shown in Fig. 4, which also shows the view of the pilot installation. To maximize the benefits of using renewable energy sources, namely solar panels, a solar panel positioning system has been developed. This system follows the sun during the day setting the panels in such a way as to maximize the amount of sunlight falling on the system. For this purpose, an algorithm was developed and implemented in which the method described in the fundamental article in the field of astronomy was used to calculate the position [5].

The positioning system has been built based on electric actuators that use a gyroscope and a controller to move the platform. In addition to the photovoltaic panel, a 300W wind turbine was installed in the system. To be able to realize the actual measurement of the amount of energy generated, the software was developed that controls the system and also allows its monitoring. The research work carried out so far has allowed initial testing of power systems. In the further part of the research phase, it will be continued in order to achieve the intended goal which is to build an autonomous power supply system for intelligent road sign data processing, data exchange, and LED-based display modules. The results achieved so far for the studied renewable energy sources indicate a large potential for using wind energy in the solution. The results obtained so far allow for generating 230 Wh per day from a wind turbine, which, with the current energy consumption by the road sign hardware at 40W, guarantees sufficient energy reserves.

a)

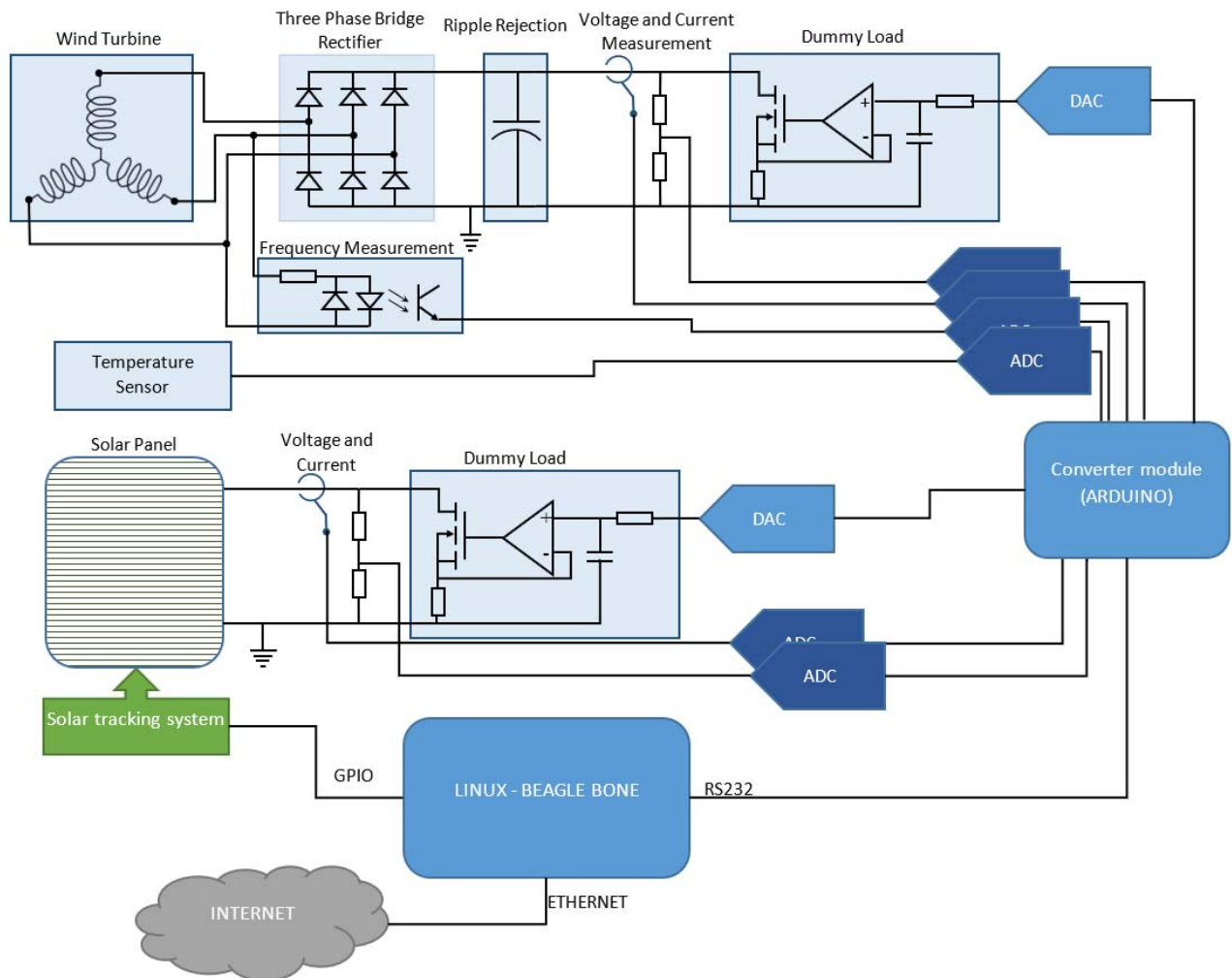

b)



Fig. 4 Block diagram of the system for testing power systems (a), diagram of the mechanical system and view of the test installation (b).

## V. CONCLUSIONS

The context of the project carried-out coincides with EU directives, e.g. the "European Union White Paper on Transport" indicating that "by 2050, almost zero deaths in road transport are assumed". In addition, the market for completely new V2X applications and solutions will be created. Without intelligent infrastructures, such as proposed in the project, it will not be more difficult to fully implement commercial autonomous vehicle technologies. Thanks to similar solutions, the vehicles will be able to communicate faster and more efficiently, as well as with the infrastructure. The bimodal nature of communicating the recommended speed (visual and in the form of messages sent electronically to vehicles) will be the first solution of this type, which does not discriminate against users of hitherto manufactured vehicles that are not yet equipped with modern data exchange systems with ICT infrastructure. The solution being developed fits into the rapidly growing trend of development of communication of cars with the road infrastructure, enabling access to digital road infrastructure for all drivers.

Commercialization of the project results is planned through their application in a business of industrial consortium partners and through the sale of license rights to the intellectual property. The planned implementation may lead to the development of products that increase road safety for which there exists worldwide market demand

## ACKNOWLEDGMENT

Project financed by the Polish National Centre for Research and Development from under the EU Operational Programme Innovative Economy No. POIR.04.01.04-0089/16 entitled: INZNAK – "Intelligent road signs with V2X interface for adaptive traffic controlling"

## REFERENCES

- [1] A. Czyżewski, "A free-standing intelligent road sign", exclusive rights certificate No. Ru70132, protection obtained on August 31, 2018
- [2] A. Czyżewski, "Hanging smart road sign", exclusive rights certificate No. Ru70133, protection obtained on August 31, 2018
- [3] A. Czyżewski, "Freestanding intelligent road sign", Patent pending No. W127001 submitted on January 23, 2018.
- [4] A. Czyżewski, "Hanging intelligent road sign" Patent pending No. W126998 submitted on 23.01.2018.
- [5] van Flandern, T. C.; Pulkkinen, K. F. Low-precision formulas for planetary positions, *Astrophysical Journal Supplement Series*, vol. 41, Nov. 1979, p. 391-411.
- [6] K. Marciniuk, M. Blaszkę, B. Kostek, Acoustic Road Monitoring, 12th International Road Safety Conference GAMBİT 2018 Road Innovations for Safety National and regional perspective, Gdańsk., 10.1051/mateconf/201823105002, 12-13.04.2018
- [7] G. Szwoch: Suppression of distortions in signals received from Doppler sensor for vehicle speed measurement. *Proc. Signal Processing: Algorithms, Architectures, Arrangements, and Applications (SPA)*, Poznan, 2018, pp. 16-21.
- [8] S. Cygert, A. Czyżewski, "Vehicle detector training with labels derived from background subtraction algorithms in video surveillance," 2018 *Proc. Signal Processing: Algorithms, Architectures, Arrangements, and Applications (SPA)*, Poznan, 2018, pp. 98-103.
- [9] J. Kotus., G. Szwoch, Calibration of acoustic vector sensor based on MEMS microphones for DOA estimation, *Applied Acoustics* 141 (2018) 307–321. DOI: j.apacoust.2018.07.025.
- [10] J. Kotus, P. Szczuko, G. Szwoch, A. Czyżewski, P. Hoffmann, A. Sroczynski, The concept of intelligent road sign for adaptive traffic regulation (INZNAK), (in Polish) XI Polish ITS Congress 2018, Warsaw, 22-23.05.2018
- [11] J. Kotus, A. Czyżewski, Counting and tracking vehicles using acoustic vector sensors, 176th Meeting of the Acoustical Society of America and 2018 Acoustics Week in Canada, Victoria, Canada, 05-09.11.2018. *The Journal of the Acoustical Society of America* 144(3):1830-1830, Sept. 2018, DOI: 10.1121/1.5068061

