



**GDAŃSK UNIVERSITY  
OF TECHNOLOGY**



**FACULTY OF  
CHEMISTRY**

The author of the PhD dissertation: Kaja Kalinowska  
Scientific discipline: Chemical Sciences

## **DOCTORAL DISSERTATION**

Title of PhD dissertation: Development of novel smartphone-based methods of wine quality assessment

Title of PhD dissertation (in Polish): Opracowanie nowych, opartych na wykorzystaniu smartfonów, metod oceny jakości wina.

Supervisor

*signature*

<Title, degree, first name and surname>

Gdańsk, year 2023



## STATEMENT

The author of the PhD dissertation: Kaja Kalinowska

I, the undersigned, agree that my PhD dissertation entitled: Development of novel smartphone-based methods of wine quality assessment

may be used for scientific or didactic purposes.<sup>1</sup>

Gdańsk, 20.06.2023

.....  
*signature of the PhD student*

Aware of criminal liability for violations of the Act of 4<sup>th</sup> February 1994 on Copyright and Related Rights (Journal of Laws 2006, No. 90, item 631) and disciplinary actions set out in the Law on Higher Education (Journal of Laws 2012, item 572 with later amendments),<sup>2</sup> as well as civil liability, I declare, that the submitted PhD dissertation is my own work.

I declare, that the submitted PhD dissertation is my own work performed under and in cooperation with the supervision of dr hab. inż. Marek Tobiszewski.

This submitted PhD dissertation has never before been the basis of an official procedure associated with the awarding of a PhD degree.

All the information contained in the above thesis which is derived from written and electronic sources is documented in a list of relevant literature in accordance with art. 34 of the Copyright and Related Rights Act.

I confirm that this PhD dissertation is identical to the attached electronic version.

Gdańsk, 20.06.2023

.....  
*signature of the PhD student*

I, the undersigned, agree/do not agree\* to include an electronic version of the above PhD dissertation in the open, institutional, digital repository of Gdańsk University of Technology, Pomeranian Digital Library, and for it to be submitted to the processes of verification and protection against misappropriation of authorship.

Gdańsk, 20.06.2023

.....  
*signature of the PhD student*

---

<sup>1</sup> Decree of Rector of Gdansk University of Technology No. 34/2009 of 9<sup>th</sup> November 2009, TUG archive instruction addendum No. 8.

<sup>2</sup> Act of 27<sup>th</sup> July 2005, Law on Higher Education: Chapter 7, Criminal responsibility of PhD students, Article 226.



## DESCRIPTION OF DOCTORAL DISSERTATION

**The Author of the PhD dissertation:** Kaja Kalinowska

**Title of PhD dissertation:** Development of novel smartphone-based methods of wine quality assessment

**Title of PhD dissertation in Polish:** Opracowanie nowych, opartych na wykorzystaniu smartfonów, metod oceny jakości wina.

**Language of PhD dissertation:** English

**Supervision:** dr hab. inż. Marek Tobiszewski

**Date of doctoral defense:**

**Keywords of PhD dissertation in Polish:** wino; aminy biogenne; związki bioaktywne; spektrofotometria; smartfon

**Keywords of PhD dissertation in English:** wine; biogenic amines; bioactive compounds; spectrophotometry; smartphone

**Summary of PhD dissertation in Polish:** Rozprawa doktorska dotyczy opracowania nowatorskiego rozwiązania analitycznego służącego ocenie jakości wina z wykorzystaniem smartfona. Rozwiązanie to oparte jest na oznaczeniu amin biogennych i wybranych związków bioaktywnych. Rozprawa doktorska oparta jest na czterech artykułach naukowych, w których zamieszczono wyniki badań. W toku prowadzonych badań wykazano, że zaproponowane podejście może być wykorzystane do oceny jakości wina z wykorzystaniem smartfona. Opracowane rozwiązanie może być modyfikowane, dzięki czemu może posłużyć do opracowywania metod oceny jakości konkretnych produktów spożywczych. Ponadto, uproszczenie procedury analizy i przygotowania próbek pozwala na zastosowanie go na każdym etapie procesu produkcji i dystrybucji.

**Summary of PhD dissertation in English:** The doctoral dissertation concerns the development of novel smartphone-based analytical methods of wine quality evaluation, which would be in line with the stipulations of green and equitable analytical chemistry. This solution is based on the analysis of biogenic amines and selected bioactive compounds. The dissertation is based on four articles containing the results of research which led to the development of smartphone-based approach. It was shown that the comprehensive analytical solution comprised of the experimental setup for smartphone-based analysis and a set of methods for the determination of multiple bioactive compounds can be used for wine quality assessment. The use of experimental setup for smartphone-based analysis facilitates modification and adaptation to particular applications. Furthermore, the portability of the setup and simplification of sample preparation procedures enable not only in-field use but also application in each stage of the manufacturing and distribution process.

## Abbreviations and acronyms

ABS	acrylonitrile butadiene styrene polymer
ABTS	2,2'-azino-bis(3-ethylbenzothiazoline-6-sulfonic acid)
BAs	biogenic amines
CE	capillary electrophoresis
DoE	design of experiment
DPPH	2,2-diphenyl-1-picrylhydrazyl
FAO	Food and Agriculture Organization of the United Nations
FFF	fused filament fabrication
GAC	green analytical chemistry
GC-MS	gas chromatography-mass spectrometry
HPLC	high-performance liquid chromatography
IR	infrared spectrometry
LOD	limit of detection
LOQ	limit of quantification
MOS	metal oxide semiconductors
NMR	nuclear magnetic resonance
OIV	International Organisation of Vine and Wine
PLA	polylactic acid-based polymer
QA/QC	quality assurance/quality control
SALLME	salting-out assisted liquid-liquid microextraction
TAC	total anthocyanins content
TBAs	total biogenic amines content
TFC	total flavonols content
TPC	total phenolic content
UV-VIS	ultraviolet-visible

## Contents

Abbreviations and acronyms .....	4
1. Introduction .....	6
1.1. Wine composition .....	6
1.2. Wine analysis – state of the art .....	9
1.3. Green and equitable analytical chemistry .....	11
1.4. Research achievement used in the dissertation.....	12
2. Research hypothesis .....	14
3. Research description.....	15
3.1. Application of smartphones in analytical chemistry .....	15
3.2. Development of a method for total biogenic amines content determination.....	18
3.2.1. Spectrophotometric measurements .....	18
3.2.2. Development of a smartphone-based procedure for biogenic amines determination .....	19
3.3. Smartphone-based wine analysis.....	23
4. Conclusions .....	26
5. Publications .....	28
5.2. Paper 2: Smartphones as tools for equitable food quality assessment 34	
5.3. Paper 3: Green, simple analytical method for total biogenic amines content determination in wine using spectrophotometry .....	44
5.4. Paper 4: Simple analytical method for total biogenic amines content determination in wine using a smartphone .....	54
5.5. Simple smartphone-based methods for the determination of bioactive compounds in wine .....	62
References.....	63
List of scientific achievements .....	86
Co-authors' statements of contribution .....	89



## 1. Introduction

Quality and safety of food are important factors contributing to the well-being of society. However, the globalization of the food market and increased production of food may have a negative impact on the quality of foodstuff through the use of raw materials of poor quality or inadequate transport and process management. Because of that, it is important to monitor the quality of food at every step of its production and distribution. While in the case of large-scale farming, it is possible to apply sophisticated equipment and labour-intensive procedures, 80% of food is produced by small and family farms, which are not able to use costly and complicated methods of food analysis [1].

Growing customers' awareness and risk of food quality decrease caused by large-scale food production justify the need for continuous food assessment at every step "from farm to fork". The development of simple methods for quality assurance could facilitate implementing routine analysis in family farms in which the alternative would be to either perform the manual assessment or dispense of it altogether. In addition, simplification of food analysis methods could serve as a means for increasing customers' engagement in quality assurance/quality control (QA/QC) and thus, result in growing accessibility of point-of-need food quality inspection.

Wine analysis is a field of food quality assessment, which also could benefit from the development of novel analytical approaches. The aforementioned issues were the motivation for my doctoral work, in which I developed a simple and comprehensive solution for the quality assessment of wine.

### 1.1. Wine composition

According to both the Food and Agriculture Organization (FAO) of the United Nations and the International Organisation of Vine and Wine (OIV), grapes are the fruit crop with the highest production value in the world with over 50% of fruits being used in wine production [2]. As a result, the production and consumption of wine are a significant part of the global food market. In 2022, 161 million hectolitres of wine were produced European Union, which is an increase of 4% compared to the year before [3].

The popularity of wine stems mostly from its pleasant taste and cultural tradition of wine consumption that can be observed in countries known for its wines e.g. France [4]. It is seen as one of the healthiest alcoholic beverages – a number of studies indicate that its moderate consumption can have a positive impact on the overall health of consumers and can even improve their life expectancy as compared with those who do not drink it at all [4], [5]. Pro-health effect of wine is linked to its antioxidant properties caused

by the fact that it is a significant source of dietary flavonols, anthocyanins and other bioactive compounds [6].

Water and ethanol are the main components of wine, constituting approx. 98% of its volume, however, wine is also composed of e.g. glycerol, higher alcohols, polysaccharides, organic acids, and polyphenols [4] (Figure 1.1.). Glycerol, which is a product of yeast fermentation, is the third most abundant constituent of both red and white wine. It is thought to be contributing to perceived wine quality by improving its mouth-feel and texture properties [4], [7]. Yeast-derived alcohols can influence the aroma profile in both positive and negative ways, since e.g. 2-phenylethanol and 3-methylbutanol are associated with “rose-like” and “solvent” aroma descriptors, respectively [8]. Compounds such as esters, terpenes, aldehydes, poly- and oligosaccharides, various aromatic compounds etc. also influence the organoleptic properties of wine, even when they are present at relatively low levels [4], [9]. Polyphenols constitute 0.1% of the overall volume of wine and thus, their content also affects the aroma of wine [4]. Moreover, due to their ability to scavenge the free radicals, content of polyphenolic compounds is a major factor influencing pro-health properties of both red and white wine [4], [7].

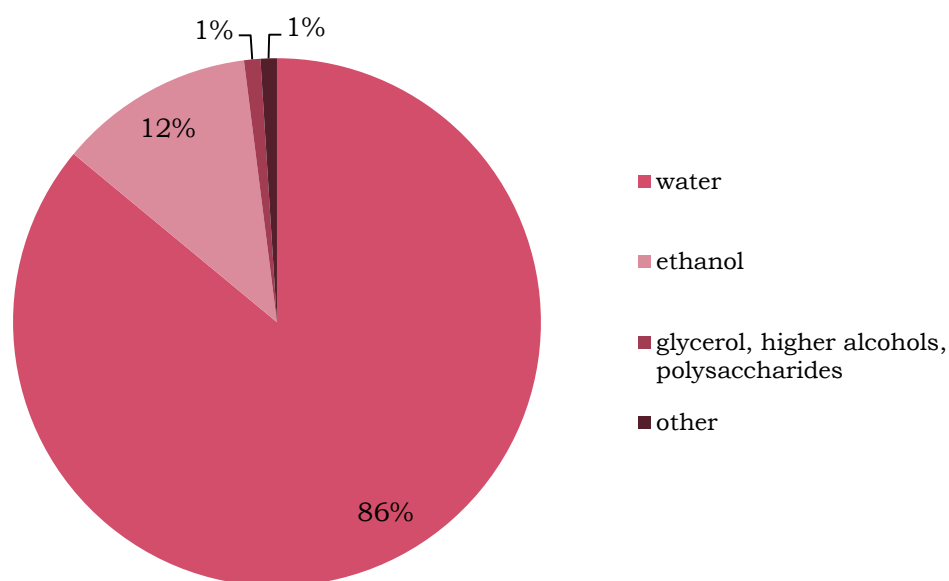

Figure 1.1. Wine composition [4].

While polyphenols found in wine are a vast and diverse group, they are classified into two groups: nonflavonoids and flavonoids [10]. Nonflavonoids in wine consist mostly of organic acids and stilbenes. Hydroxybenzoic and hydroxycinnamic acids are the most abundant ones

in red and white wine, although e.g. vanillic, salicylic, and gallic acids can also be found [6], [11]. Stilbenes are phenolic compounds present in both grapes and products made from them, their levels in wine may vary significantly depending on the location where they were grown or the colour of the wine [12]. Resveratrol is one of the stilbenes present in wine at the highest levels, other compounds such as piceatannol or pallidol are also found [4], [7].

Flavonoids consist of flavanols, flavonols, flavanones, flavones, chalcones, anthocyanins, and tannins. Flavanols contribute to the organoleptic characteristics of wine by e.g. influencing its colour, astringency and bitterness [11]. Catechin and epicatechin are the most common flavonols - they can be found in the skin and seeds of grapes and thus, they are present in all types of wine [7]. However, their concentration in red wine is significantly higher than in the case of white wine [4].

Flavonols in wine comprise mostly of quercetin, myricetin, engeletin and laricitrin [7], [13]. Glycosylated flavonols are present in red and white wine since they can be found in the skin and stems of grapes [4], [7]. They affect the aroma of wine and its colour as they form co-pigments with anthocyanidins [7].

Anthocyanins (anthocyanidin-glycosides) are water-soluble pigments, naturally occurring in many fruits, including grapes. They are present in red and rosé wine with the most abundant compounds being isomers of cyanidin, petunidin and delphinidin. They are responsible for the intense colour of young wine, but their stability depends on various factors including pH or storage conditions [4]. Moreover, anthocyanins content decreases during the ageing of wine, because they react with other compounds [14].

Condensed tannins, also called proanthocyanidins, are products of reactions of flavonols and their derivatives, while hydrolysable tannins originate from oak barrels used during the ageing of wine [15]. The increase of their levels is related to the increased bitterness and astringency of wine [16]. Levels of tannins may vary significantly between different wines, though the concentration of proanthocyanidins in red wines is in general several-fold higher than in white and rosé wines [10], [15].

Another worth-mentioning group of compounds present in wine are nitrogenous substances. Proteins, polypeptides, amino acids, biogenic amines etc. can be found in wine since they usually derive from grapes or are created due to fermentation and yeast activity [9]. While the amount of amino acids, polypeptides and proteins is usually diminished during the course of wine production (through natural processes or by producers' intervention), biogenic amines' impact on the quality of wine is often overlooked [9], [17].

According to the literature, more than 15 biogenic amines (BAs) have been identified in red, white and rosé wines [17]. Their presence in wine



is caused by e.g. composition of grapes or metabolism of yeast, however, low sanitary quality of wine may result in increased concentration of BAs [17], [18]. Microbial contamination, poor quality of raw material, and inadequate processing and storage conditions can influence the concentration of biogenic amines and thus, their determination can be a useful tool for monitoring of sanitary quality of food [19]. Because of that, their levels are monitored in the case of different products e.g. meat [20], [21], fish [22], and wine [23], [24]. However, monitoring the level of BAs is important in the case of wine also because the presence of ethanol and acetaldehyde may increase their negative impact on organoleptic properties and the overall safety of wine [18]. As a result, OIV recommends a reduction of biogenic amines content in wine and other vine-based products [18].

As can be seen, determination of biogenic amines can provide useful information on safety and sanitary quality of wine. On the other hand, levels of bioactive compounds such as flavonols could be the basis of assessment of wine's pro-health features. As a result, simultaneous determination of compounds with positive and negative impact on wine characteristics could be a means of obtaining comprehensive information on wine quality and safety.

## **1.2. Wine analysis – state of the art**

A wide variety of analytical methods are applied as a means of obtaining information about wine composition in all stages of production, from growing grapes to bottling and certification of wine. First and foremost, analysis is performed in order to evaluate whether wine is in compliance with regulations concerning food safety. Secondly, wine quality is evaluated for marketing purposes e.g. to authenticate or confirm its origin, which can result in an increase in value or sales. Analysis of wine can be also performed in order to obtain information concerning processes involved in wine production and thus, increase the body of knowledge in the field of wine manufacturing and research.

Chromatographic methods are a gold standard in the case of wine analysis due to the variety of wine constituents present at different levels. With their application, it is possible to perform in-depth investigation of wine's chemical composition [25]. Because of that, gas chromatography (GC) and liquid chromatography (LC), often coupled with mass spectrometry (MS), are employed for the determination of multiple analytes in wine. Gas chromatography coupled with various detection systems is particularly useful in the case of wine aroma investigation since it is suitable for the analysis of a diverse range of volatiles [25]. LC-MS is often applied in metabolomics studies, while high-performance liquid chromatography (HPLC) coupled with ultraviolet (UV) or fluorescence detectors are used in quantitative analysis for regulatory purposes [25]. Moreover, chromatographic methods are employed not only in the case of a vast range

of foodomics studies but also for the determination of compounds that can be detrimental to the health of the consumer even when they are present at relatively low levels e.g. pesticides or mycotoxins [26], [27]. However, even fast and ultra-fast incarnations of chromatographic methods are not ideal for monitoring wine quality at different stages of its production and distribution or for field measurements due to laborious sample preparation, lengthy process of chromatographic separation, and the need for skilled operators.

Another technique used in wine analysis is capillary electrophoresis (CE). While it is characterized by worse sensitivity and robustness than chromatographic methods, its versatility as well as a shorter time of the analysis resulted in the application of CE in wine and grape analysis [28], [29]. Moreover, capillary electrophoresis is especially useful in the case of wine constituents, e.g. organic acids, that can be easily separated from other compounds on the basis of relative mobility difference and thus, the sample preparation step can be omitted [25], [28], [30]. However, while a decrease in sensitivity is not of particular importance in the case of routine and in-field analysis, CE's use still requires a skilled operator.

Spectroscopic methods are also employed in wine analysis with a vast range of instruments used for different purposes. Atomic spectroscopy, e.g. flame absorption spectroscopy, is often applied in research concerning the elemental composition of wine [31], [32]. Due to its sensitivity, inductively coupled plasma-mass spectrometry can be especially useful for the determination of trace elements [33], [34]. Nuclear magnetic resonance (NMR) spectroscopy has proven to be useful in wine authentication [35]. However, while MS can be applied for wine analysis directly [33], [36], [37], in a majority of research it is used with either chromatographic or spectroscopic systems [25]. Infrared spectrometry (IR) and ultraviolet-visible (UV-VIS) spectrophotometry are more commonly used in wine quality evaluation since their use is quick and relatively easy [38]–[40]. Although they are less sensitive than chromatographic methods and not suitable for the determination of compounds present at trace levels, IR spectrometry and spectrophotometry are often employed for routine analysis such as sulphur dioxide determination or for 'non-specific' determination of groups of compounds e.g. measurement of total phenolic content [39], [41], [42]. Moreover, while information concerning the levels of individual compounds is beneficial for increasing the body of knowledge, it is not always necessary in the case of quality evaluation and thus, simple and rapid methods are favoured over e.g. chromatography. Total anthocyanin content and other results of spectrophotometric determination are of particular importance in the case of routine quality assurance in the industrial setting, since they provide useful information concerning the quality of wine without the need to perform complicated, expensive and time-consuming analysis [42].

Another method that could find its application in routine wine quality assessment is use of electronic nose and electronic tongue [43]. Coupling of an electronic nose or tongue, devices equipped with an array of chemical sensors, and chemometrics could be a viable tool for rapid, non-destructive monitoring of wine properties [43], [44]. Based on the existing literature, it can be concluded that this solution can be used for e.g. monitoring wine ageing or for discrimination between different wine samples [43], [45]. However, the majority of electronic noses are equipped with metal oxide semiconductors (MOS), which makes them susceptible to ethanol and humidity in general, which hinders their application in the analysis of the volatile fraction of wine [21]. The application of electrochemical sensors could facilitate in-field analysis since they are characterised by lower power consumption than MOS sensors and resilience to changes in humidity. Nevertheless, electronic olfaction's application in food quality evaluation is dependent on the machine learning model and vast set of results necessary for its training and thus, requires a skilled operator [21], [43].

Smartphones could be another tool for wine quality evaluation. The ubiquity of smartphones created a possibility for the introduction of novel, accessible-to-end-user analytical methods, which could be used in food quality assurance [46]. The smartphone-based analysis could, provided that certain methodological difficulties are overcome, combine the advantages of both spectrophotometry and electronic olfaction since its application is inexpensive, easy, and widely accessible [46], [47]. What is more, such a solution for wine quality assurance would be in line with provisions of green and equitable chemistry, which focus on both reducing the environmental impact of the analytical method and increasing its availability to end-users i.e. consumers.

### **1.3. Green and equitable analytical chemistry**

Analytical chemistry plays a crucial role in environmental protection since various analytical procedures can be used for the determination of pollutants and other compounds that could be potentially harmful or undesirable [48]. However, it is also important to consider the impact that the implementation of those procedures can have on both environment and the safety of the operator. 12 principles of green analytical chemistry (GAC) were created in order to point to environmental aspects that should be taken under consideration during both the selection of the procedure for a particular purpose and the development of novel analytical methods [49].

The environmental impact of the analytical methods is often indirectly addressed during the evaluation of their economic aspects, since e.g. reduction of the reagents' use and waste produced or lowering energy consumption is not only cost-effective but can also reduce the overall environmental footprint of the method [50], [51]. However, when a greener alternative is not as cost-effective, a more direct approach is needed [52].



Moreover, while it is important to work towards greener analytical procedures in general, it is also worth remembering that environmental impact is cumulative and thus, it increases with the number of analysed samples. As a result, implementation of GAC's stipulations is of particular importance in the case of routine analysis, such as food quality control. Since over 250 million hectolitres of wine is produced annually, the development of green methods of its analysis could significantly impact the environment [3], [25].

Another, often overlooked aspect of analytical procedures is their social dimension. The main aim of analytical chemistry is to provide information in accordance with the requirements and needs of end-user [53]. As a result, information obtained through the use of analytical methods should be available not only to a narrow group of scientists but also to society. The main idea behind equitable chemistry is that ensuring widespread accessibility of analytical chemistry is as important, as its environmental and economic aspects [54]. In the case of food analysis, equitability should be ensured by the widespread availability of understandable information concerning both the safety and quality of the food products. Ideally, the safety of e.g. wine should be evaluated at all stages of distribution and conveyed to the potential consumer. For this reason, novel analytical methods should be not only characterized by the low environmental impact but also designed in a way that could facilitate their application by non-trained users. This could be achieved with the use of readily available everyday devices, such as desktop scanners or smartphones [46], [55].

#### **1.4. Research achievement used in the dissertation**

The dissertation is based on a series of four articles containing a description of the research which resulted in the development of a smartphone-based approach enabling the evaluation of wine quality. Within the publication cycle, a literature review was performed, which was presented in two review publications:

- (Paper 1)** Kalinowska, K., Bystrzanowska, M., Tobiszewski, M., Chemometrics approaches to green analytical chemistry procedure development (2021) *Current Opinion in Green and Sustainable Chemistry*, 30, 100498, DOI: 10.1016/j.cogsc.2021.100498;
- (Paper 2)** Kalinowska, K., Wojnowski, W., Tobiszewski, M., Smartphones as tools for equitable food quality assessment (2021) *Trends in Food Science and Technology*, 111, 271. DOI: 10.1016/j.tifs.2021.02.068.

The results of the experiments have been described in two papers:

- (Paper 3)** Kalinowska, K., Tobiszewski, M., Green, simple analytical method for total biogenic amines content determination in wine using spectrophotometry (2023) *Food Chemistry*, 402, 134457. DOI: 10.1016/j.foodchem.2022.134457;



**(Paper 4)** Kalinowska, K., Wojnowski, W., Tobiszewski, M., Simple analytical method for total biogenic amines content determination in wine using a smartphone (2023) *Analytical Methods*, 15 (11), 1395. DOI: 10.1039/d2ay02035a.

The results important for the dissertation have been also published in papers published in *Food Chemistry and Microchemical Journal*. The methods described in these publications were applied as reference methods for this dissertation. Important results are also presented in unpublished manuscript: *Simple smartphone-based methods for the determination of bioactive compounds in wine*.

## 2. Research hypothesis

The development of novel analytical methods for wine quality assessment requires a multi-faceted approach, as indicated in the previous chapter of this thesis. Thus, the main goal of this work was to develop a comprehensive and novel solution for the assessment of wine quality, which could be used to supplement already existing methods or as a stand-alone means for food analysis. The developed solution should be characterised by low cost, low environmental impact, and satisfactory analytical figures of merit. Its development required at least partial realisation of the following research goals:

- the development of an experimental setup for smartphone-based wine analysis;
- establishing a novel smartphone-based method for biogenic amines content determination and a reliable reference analytical procedure;
- development of novel methods of selected bioactive compounds' determination, which would be in line with the stipulations of green and equitable analytical chemistry.

Since development of novel comprehensive solution for food quality evaluation is a complex challenge, realisation of described research goals requires the pursue of multiple aspects. The results of the preliminary research together with a literature review made it possible to establish the following tasks:

- development of a measuring procedure, which would be used for spectrophotometric determination of biogenic amines in wine;
- establishing a smartphone-based method for biogenic amines determination, which would serve as dedicated solution for wine quality assessment;
- development of reference method for biogenic amines determination using gas chromatography coupled - mass spectrometry which could be employed in order to validate proposed smartphone-based solution;
- development of complementary smartphone-based methods for bioactive compounds determination in wine;
- complimentary use of developed methods as a means for wine quality evaluation;
- validation of the developed concept by juxtaposing the obtained results with the results of reference methods of wine quality assessment.

The realisation of described research tasks is described in the Chapter 3 and discussed in detail in works included in Chapter 5.

### 3. Research description

The goals indicated in Chapter 2 were outlined based on the result of an extensive literature review and a number of preliminary studies that were carried out in the first years of the PhD. This made it possible to determine the state of the art of the use of smartphones application in food analysis and analytical chemistry in general and to identify the aspects of their application which could be improved, which in turn translated into the development of experimental setup for smartphone-based analysis of wine. Thus, the concept for the execution of the doctoral thesis was developed and depicted in Figure 3.1.. Each of the stages will be further discussed and described in the following sections of the chapter.

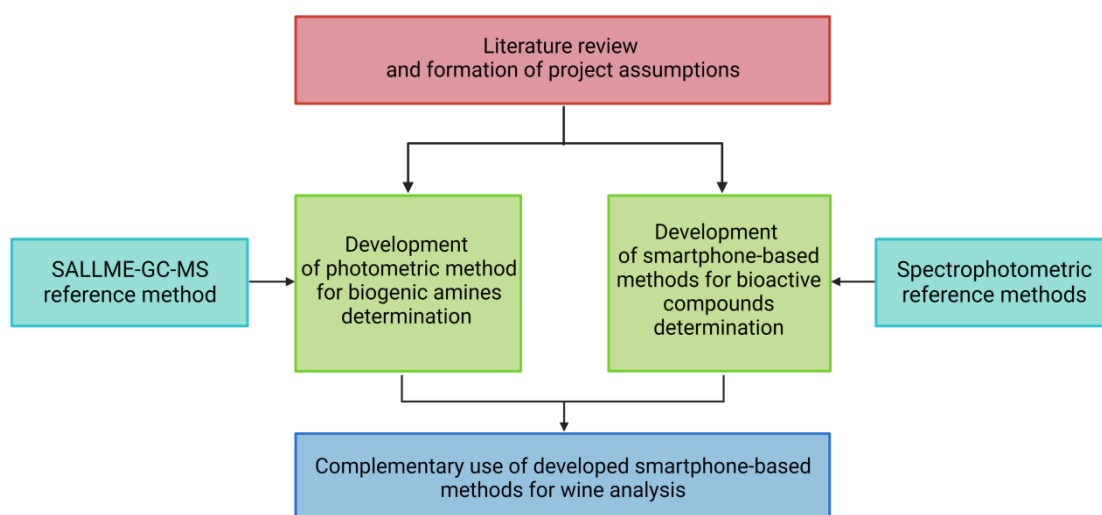

Figure 3.1. The scheme of research concept carried out during the doctoral thesis. Created with BioRender.com.

#### 3.1. Application of smartphones in analytical chemistry

The aim of green analytical chemistry is to reduce the negative impact that analysis can have on both the environment and human health. There are many different approaches that could be applied towards GAC and thus, there are multiple papers concerning greening of the analytical procedures. A literature review pertaining to this subject was described in the first article comprising the dissertation, Paper 1. Based on its results, it can be concluded that since green analytical chemistry is multivariate, the best approach is to tackle multiple factors influencing the greenness of the procedures at once. However, while the awareness of the environmental footprint of analytical chemistry and chemistry in general is steadily increasing, in many cases this aspect is addressed by improving singular parameters e.g. shortening the time of the analysis or use of greener mobile phase.

The reduction of the environmental footprint of analytical processes can be achieved using different strategies from the application of microextraction techniques to the use of solventless or direct techniques [56], [57]. Moreover, the environmental impact of the analytical method's implementation is often indirectly considered when economic aspects are evaluated, since reducing the cost of analysis by e.g. reducing the volume of reagents and generated wastes or increasing the sample throughput might increase the greenness of proposed methods [51]. However, from a green analytical chemistry point of view, it is important to work towards reducing the negative impact of the analysis on the environment in a more direct and purposeful way. This could entail e.g. favouring analytical methodologies which do not affect the analyst's health or the environment, evaluating whether unwanted and/or hazardous by-products are formed or scaling procedures so that reagents' use is minimal. Stipulations of green analytical chemistry, notably its 12 principles should be implemented during developing, selecting and modifying procedures used in food analysis [48], [49], [52].

The application of chemometrics as a means of implementing principles of GAC is an important but often overlooked possibility. Chemometric tools can be used not only to facilitate data analysis but also in order to simplify the process of the development of novel analytical methods. With their use, it is possible to select the most important variables, which should be optimized and to identify the irrelevant aspects, which could be disregarded. As a result, only the parameters deemed influential have to be optimized and thus, the use of reagents and energy consumption can be decreased. Moreover, since aspects of analytical procedure which do not affect its figures of merit can be identified, one can assess where a greener approach can be applied without decreasing e.g. selectivity or precision. What is more, the Design of the Experiment (DoE) can be applied in order to find the suitable values of the influential parameters in fewer experiments than in the case of one-at-the-time optimization. This approach can not only increase the chances of finding the optimal conditions of the analysis but also reduce the cost and environmental footprint of the analytical procedure's development [56]. All of these advantages are of particular importance in the case of food quality analysis, since cost and safety have a direct impact on the quality of foodstuff [47], [58].

The application of smartphones as a promising tool for food analysis is another subject that is steadily gaining interest and thus, a substantial number of research papers on this topic have been published. The critical review of the subject literature has been described in detail in the second article comprising this thesis, Paper 2. Based on the results of the review, it was possible to conclude that the use of smartphones in analytical chemistry is one of the most promising routes for increasing the accessibility of food analysis to end-user and enabling them greater participation in the QA/QC process. Due to their ubiquity, portability and set of features



such as network connectivity, processing capabilities and accessible connectivity, smartphones are being implemented in analytical chemistry [59]. However, in many cases, the implicit promise of smartphone-based analytical chemistry is in reality far from being true.

Smartphones are often applied as a means of providing a graphic user interface or as a more convenient tool for data acquisition and processing, while the actual analysis is performed with the use of a peripheral device. When smartphone-based detection is implemented, analysis is usually preceded by laborious and time-consuming sample preparation that involves the use of devices typically only found in laboratories. Such complexity negates the main advantages of using smartphones since it not only might discourage potential end-users but also severely limits the possibility of applying developed methods in field conditions [47]. In addition, the performance of smartphone-based methods is rarely evaluated on the basis of the same analytical figures of merit as other analytical procedures – studies either focus on issues associated with the use of smartphones such as inter-model transferability or assess the usability of the proposed method solely based on a singular characteristic (e.g. limit of detection) [47], [60]. Nevertheless, integration of the already-existing methodologies for food analysis with smartphone-based detection systems and the development of novel smartphone-based methods are promising routes for increasing the accessibility of analytical chemistry, provided certain methodological difficulties are overcome.

The main conclusion of the literature review in the context of this thesis, apart from the potential applicability of smartphones in food analysis, is the need to develop and validate simple, robust, and reliable smartphone-based methods for wine analysis. It was noted that most of the research focuses first and foremost on the determination of particular analytes chosen on the basis of their positive or negative impact on human health without taking into account the overall quality of the wine, which due to the complexity of the matrix cannot be assessed based on singular parameter. However, due to the fact that poor quality of raw materials, inadequate food processing, and microbial contamination can result in increased content of biogenic amines, their determination can give useful information on spoilage and the overall quality of food [19], [61]. Therefore, in the course of the literature research, it was decided that the early studies should be focused on the determination of biogenic amines content as one of the means of assessing the sanitary quality of wine, as is often used in case of e.g. meat or fish [20], [22]. Since most of the research concerning smartphones' application in food analysis is based on their use as more portable spectrophotometers, it was concluded that spectrophotometric detection will be employed in preliminary studies on biogenic amines determination in wine. The results of this study were described in *Paper 3*.

Another conclusion drawn from the review is that although there are many solutions which involve the use of smartphones, there is still a lack of dedicated solutions that could be used in a non-laboratory environment (e.g. in the industry or households). This is mainly due to the use of sample preparation protocols that require laboratory equipment and expensive reagents, which may be difficult to implement outside of the controlled laboratory conditions [62]. Therefore, the development of a solution for wine analysis should be performed with accessibility in mind, so that both detection and sample preparation could be easily performed in a non-laboratory setting.

The final conclusion of the review, widely commented on in both *Paper 1* and *Paper 2*, is the need to focus not only on widening the accessibility of analytical chemistry but also on reducing the detrimental impact that food analysis can have on the environment and the health of the operator. Because of that, it was concluded that chemometric tools, such as DoE, will be applied to optimize the developed method for biogenic amines determination so that fewer experiments will be needed and thus, impact on the environment will be minimised. This and previous findings from the review served to outline the main research questions for the development of a comprehensive solution for smartphone-based wine quality evaluation.

## **3.2. Development of a method for total biogenic amines content determination**

### **3.2.1. Spectrophotometric measurements**

Prior to the formulation of design assumptions for the development of a smartphone-based method for biogenic amines determination, preliminary studies on the usefulness of photometry were conducted and described in *Paper 3*. The aim of this study was to develop a simple, green procedure for total biogenic amines content determination that could be potentially used in the field condition. In order to further decrease environmental impact, optimization of the method was carried out using the DoE instead of the commonly used one-time-factor procedure with four major factors evaluated using Box-Behnken design. Finally, the greenness of the developed method was assessed using AGREEprep and then, its applicability was demonstrated through red and white wine samples analysis [63].

Application of cyanine dye S 0378 ( $C_{37}H_{44}ClN_2NaO_6S_2$ ) for the determination of total biogenic amines content in wine was described for the first time in *Paper 3*. This commercially available dye reacts with primary amines according to the  $SN_1$  mechanism, which results in a visible change of the solution's colour from green to blue. Studies showed that absorbance at 650 nm increased with the increase of biogenic amines content and thus, it was possible to use photometric analysis to determine their content. The impact of the volume of triethylamine and ethanol, as well as the time and temperature of the reaction on the yield of the reaction

was assessed in the course of just 29 experiments - 24 runs with factors examined at three levels (-1, 0, 1) and 5 centre points for the experimental error estimation. The optimized procedure allowed for fast, uncomplicated and cost-effective analysis of total biogenic amines content. In order to further facilitate the evaluation of total BAs content, results were expressed as putrescine equivalent, which is a common approach in spectrophotometric food quality evaluation [64]–[66]. While obtained limits of detection and quantification were much higher than in the case of chromatography-based methods, the aim was to develop a useful tool for monitoring food quality and ensuring food safety in terms of biogenic amines content, which does not require the determination of particular amines. Moreover, while there is no regulatory limit concerning the concentration of biogenic amines in wine, existing studies and regulations regarding their content in food (with e.g. up to 25 mg/meal of histamine viewed as not causing any health effects) suggest that the concentration of biogenic amines deemed unsafe falls well below method's limit of quantification [67], [68]. As a result, the proposed method can facilitate wine quality assessment outside of the laboratory. Furthermore, since the procedure involves only a few straightforward operations in the sample preparation step, it can be performed by people without prior analytical chemistry experience, which further increases the potential availability of the method. However, while the results of the greenness assessment suggested that the developed procedure's environmental impact is lower than in the case of e.g. chromatographic methods, it was determined that there is room for improvement when considering the potential accessibility of photometric wine analysis to end-users.

### **3.2.2. Development of a smartphone-based procedure for biogenic amines determination**

Following the project goals, an experimental setup for smartphone-based analysis was designed to assess the quality of wine, including the determination of biogenic amines content. A detailed description of the method and examples of its application were published in *Paper 4*.

The experimental setup for the smartphone-based analysis consists of a smartphone, light source and 3D-printed component designed to facilitate taking reproducible images of the illuminated sample while eliminating interfering variables such as exposure to ambient light or differences in the focal distance (Figure 3.2.). Coupling of 3D-printing with smartphone detection increases the availability of the proposed solution due to the possibility of on-site manufacturing of personal devices designed for a particular sample and created in a way that easily matches individual models of smartphones [69]. This is further facilitated by the increasing accessibility of fused filament fabrication (FFF) technology and freeware parametric design software [69], [70]. The polymer material used for

3D-printing was selected on the basis of the literature review and studies carried out in the first years of the PhD concerning the user's exposure to potentially harmful volatile chemical compounds during printing. PLA (polylactic acid-based) filament was selected since it was demonstrated that emission associated with printing with it is potentially less harmful than the use of other popular desktop printer filaments such as ABS (acrylonitrile butadiene styrene) polymer [71], [72]. Moreover, it is not only ubiquitous but also bio-based which further increases the accessibility and greenness of its application.

As a result of preliminary studies, it was decided to 3D-print the designed set-up in four parts using Prusa i3 MK2s FFF 3D printer (Prusa Research a.s., Prague, Czech Republic). The first element is an adjustable smartphone mount, which can be modified in order to accommodate smartphones with in-axis and off-axis configurations. It is connected with a tubular interface which is slightly longer than the minimum focusing distance of a particular phone in order to facilitate taking reproducible images. The sample is placed in a standard 10 mm optical cell cuvette, placed in-axis with the camera, covered with a snap-on cap to shield it from ambient light, and back-illuminated with LED individually chosen for each determination, so that the wavelength of maximum absorbance is within the range of particular light source. The 3D model of the whole setup is licensed under the Creative Commons – Attribution license and thus, available for download, adjustment and printing.

Image analysis, namely area selection and colour measurement, was performed using ImageJ (Rasband, W.S., ImageJ, U. S. National Institutes of Health, Bethesda, Maryland, USA, <http://imagej.nih.gov/ij/>). Mean values of the R channel of the selected area (50 x 50 pixels) were measured. Least squares linear regression was used to calculate the equation of the calibration curve and the determination coefficient ( $R^2 = 0.9981$ ). It was found that the proposed method displays satisfactory figures of merit and thus, can be used for food analysis.



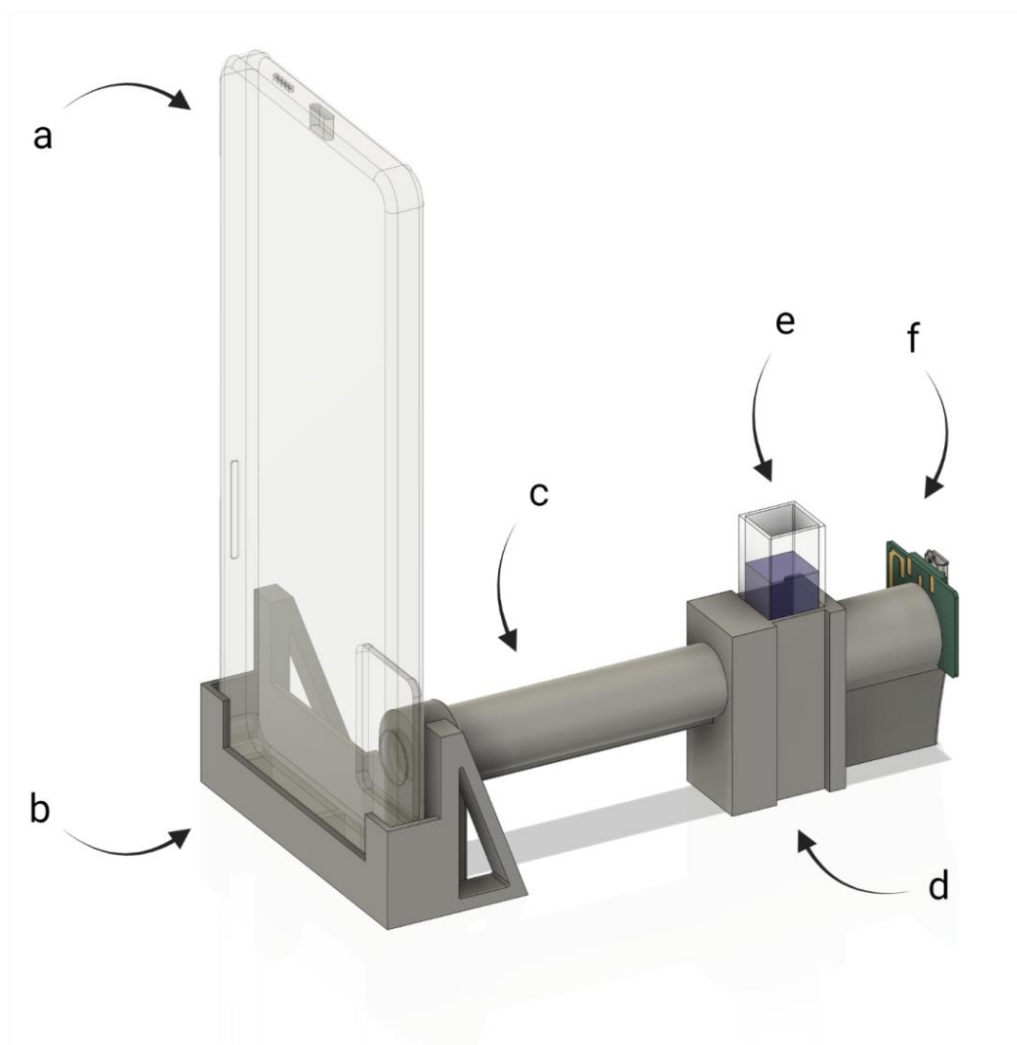

Figure 3.2. 3D-printed smartphone-based setup comprised of a smartphone equipped with a digital camera (a), a smartphone mount (b), a distance piece matching the approximate minimum focal distance of the smartphone's main camera (c), a cell compartment raised from the base to accommodate different smartphone camera positions relative to the case edge (d), a standard 10 mm spectrometer cell cuvette containing the sample (e), a custom PCB fitted with a LED, a resistor, and a micro-USB connector (f).

Using described experimental setup, 16 Polish wine samples were analysed. In order to evaluate whether the proposed method for total biogenic amines content can be used in wine quality evaluation as a simpler alternative to the determination of particular amines, obtained results were compared with those obtained using the reference chromatographic method. Salting-out assisted liquid-liquid microextraction combined with gas chromatography-mass spectrometry (SALLME-GC-MS) method used for cross-validation was established during the course of PhD studies and described in detail in the articles by Fabjanowicz et al. 2022 [23], Różańska et al. 2022 [73], and Paper 4. While the use of chromatography is usually characterised by a relatively high environmental footprint, SALLME-GC-MS was developed and chosen by reference method with stipulations of green analytical chemistry in mind. In order to increase the greenness



of identification and quantification of biogenic amines with GC-MS, *in situ* derivatization was coupled with microextraction and thus, the use of hazardous reagents was reduced.

On the basis of results obtained using the GC-MS-based method, the putrescine equivalent was calculated and then compared with the results of smartphone-based analysis (Figure 3.3.). F-test and Student's *t*-test were used to assess whether the results are equivalent. It was found that both sets of results do not differ in a significant manner, which further proved the applicability of the proposed smartphone-based method.

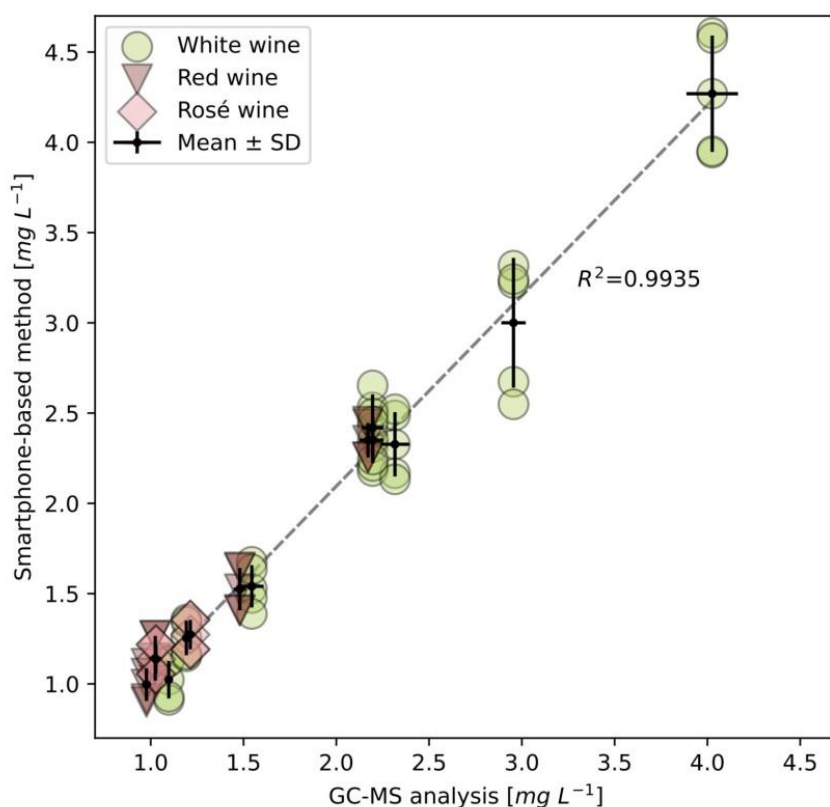

Figure 3.3. Result of determination of the total biogenic amines content. Horizontal and vertical error bars denote SD ( $n = 5$ ) for the GC-MS and smartphone-based methods, respectively.

The developed procedure for determination of the total biogenic amines content in wine is simple to perform and green. It conforms with the postulates of green analytical chemistry to a greater extent than alternative instrumental analytical methods for the determination of biogenic amines due to the simplification of the sample preparation and determination. The use of smartphones drastically increases the accessibility of the proposed procedure, which would otherwise require highly-trained personnel, costly equipment, and infrastructure that cannot be found outside of the laboratory setting. Reduction of the number of analytical steps in a procedure results in reduced consumption of reagents

and increased user-friendliness, and thus, can be a sustainable alternative for other methods for biogenic amines content determination.

### 3.3. Smartphone-based wine analysis

The final stage of the described research was the use of the developed smartphone-based methods to assess the levels of bioactive compounds in wine using spectrophotometry as a reference. The experimental set-up described in *Paper 4* has been used in order to evaluate the applicability of smartphone-based techniques for wine analysis and to evaluate whether the interaction between levels of particular compounds can be observed (Figure 3.4.). Results of the wine analysis, which are not yet published, are enclosed as a part of Chapter 5.

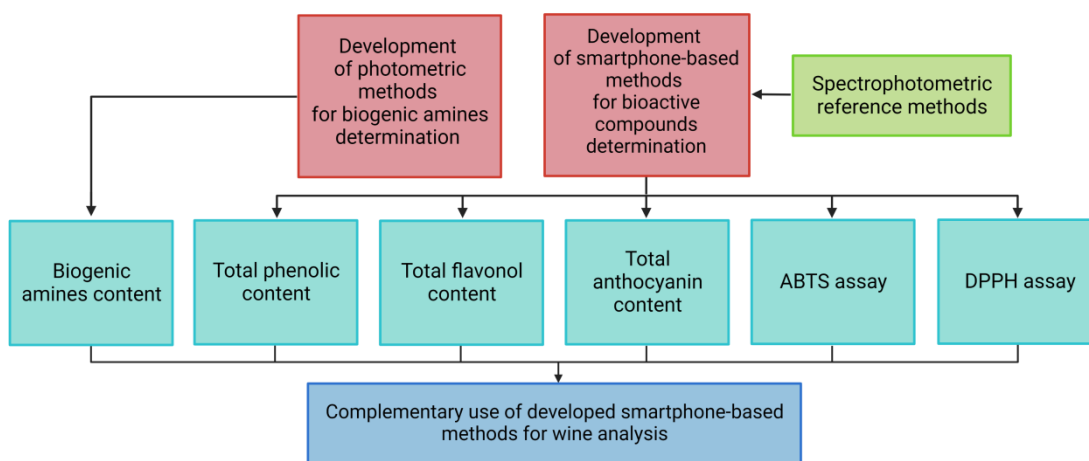

Figure 3.4. The scheme of wine analysis carried out during the doctoral thesis. ABTS assay - antioxidant capacity assay with the use of 2,2'-azino-bis(3-ethylbenzothiazoline-6-sulfonic acid), DPPH assay - radical scavenging activity assay with the use of 2,2-diphenyl-1-picrylhydrazyl. Created with BioRender.com.

All smartphone-based methods were validated and obtained satisfactory figures of merit. Determination coefficients were in the range of 0.9860 - 0.9981, which is comparable with those obtained for spectrophotometric methods (0.9864 - 0.9979). Limits of detection (LOD) and limits of quantification (LOQ) were comparable to those calculated for spectrophotometric methods. Recoveries obtained for smartphone-based methods were slightly lower than those calculated for spectrophotometric determinations (96 - 102% and 99 - 103%, respectively), but both approaches were characterised by high accuracy.

Smartphone-based and spectrophotometer-based methods were used in order to analyse commercially available wines. As can be seen in the example of total phenolic content determination (Figure 3.5.), results obtained using both means are similar. In most cases, the application of smartphones results in only a slightly poorer precision.



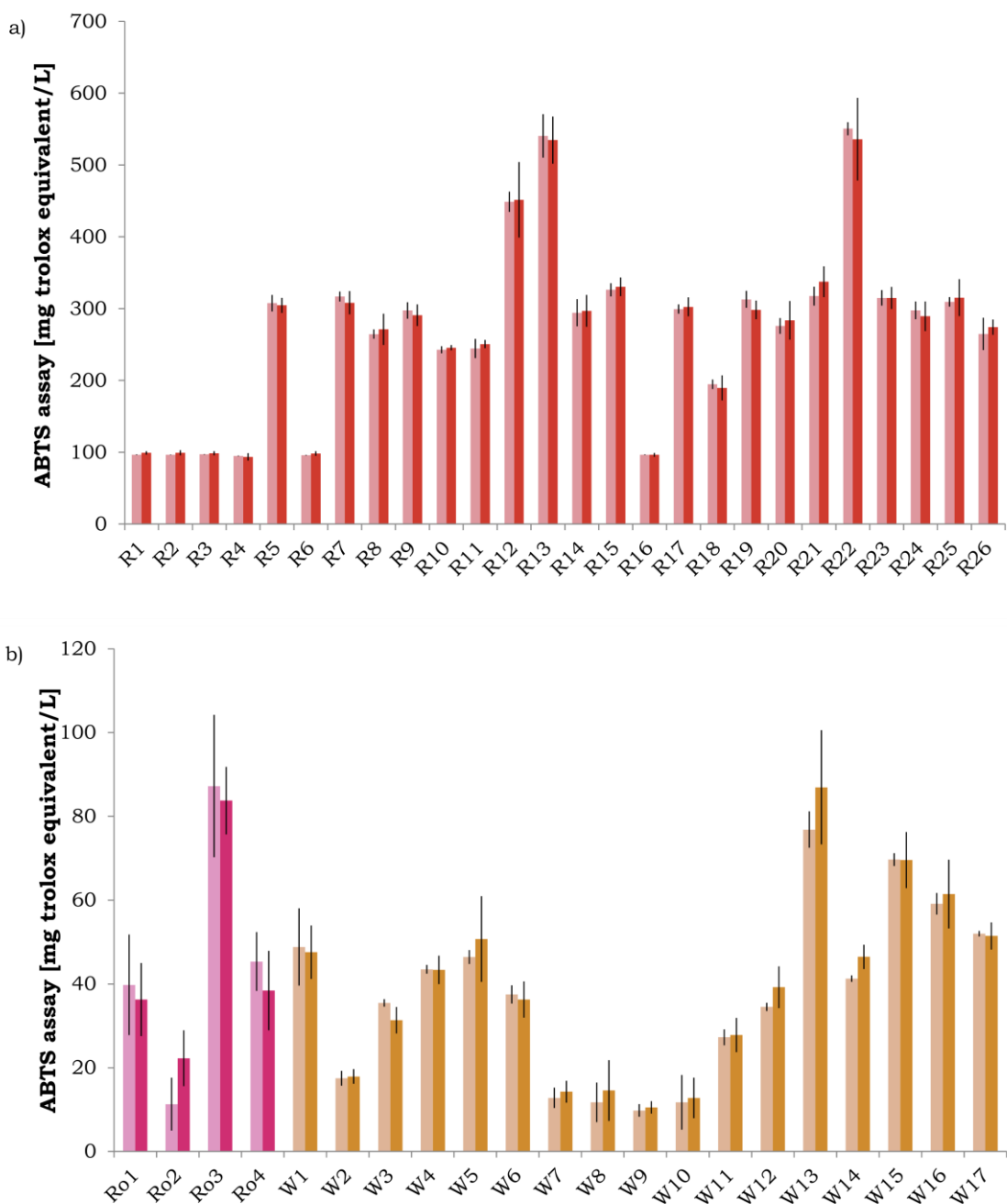

Figure 3.5. Results of total phenolic content determination in a) red, b) rosé and white wine using spectrophotometer and smartphone (depicted in darker and lighter colours, respectively). Black error bars denote SD (n=5).

In order to evaluate the correlation between measured variables, an exploratory analysis was performed. As can be seen in Figure 3.6., while some correlation can be observed between the content of e.g. anthocyanins and phenolic compounds, an abundance of factors affecting the content of bioactive compounds makes it impossible to find straightforward relation between the content of particular analytes [6], [74]. This further prove that in order to obtain comprehensive information on wine



quality, simultaneous determination of multiple analytes should be performed in lieu of singular measurement. What is more, no significant correlation between biogenic amines content and other variables was observed and thus, BAs determination can be a means to thorough wine quality assessment.

	TPC	TFC	ABTS	TBAs	TAC	DPPH
TPC	1.00	0.62	0.73	0.51	0.77	-0.39
TFC	0.62	1.00	0.84	0.72	0.59	-0.14
ABTS	0.73	0.84	1.00	0.64	0.64	-0.07
TBAs	0.51	0.72	0.64	1.00	0.58	-0.23
TAC	0.77	0.59	0.64	0.58	1.00	-0.40
DPPH	-0.39	-0.14	-0.07	-0.23	-0.40	1.00

Figure 3.6. Correlation matrix for different smartphone-based measurements: TPC – total phenolic content, TFC – total flavonols content, ABTS – ABTS assay, TBAs – total biogenic amines content, TAC – total anthocyanins content, DPPH – DPPH assay

## 4. Conclusions

The following could be considered the main achievements and aspects of novelty of this dissertation:

- the development of an experimental setup for smartphone-based food analysis, which is particularly well-suited for wine analysis;
- development of a novel smartphone-based method for biogenic amines content determination and a reliable analytical procedure which can be used to obtain reference values;
- development of smartphone-based methods of selected bioactive compounds' determination, which are in line with the stipulations of green and equitable analytical chemistry;
- application of the above-mentioned methods in the analysis of wine obtaining very good results;
- the use of the holistic approach to the smartphone-based analysis of wine.

Based on the literature review it was concluded that the lack of large-scale introduction of the smartphone in the food analysis is caused partially by the lack of reliability of proposed solutions and difficulties stemming from the lack of inter-model transferability. This problem was addressed by designing the experimental setup for smartphone-based detection. It features a 3D-printed module designed in a way to decrease interferences stemming from performing analysis with different smartphones and in varying field conditions. Perhaps more importantly, owing to the modular design, the setup can be tailored to a particular matrix and smartphone model. Therefore, the device can be easily adapted to testing the application of smartphones in specific scenarios, thus facilitating the development of case-specific solutions.

This novel analytical setup has been employed for the determination of biogenic amines in wine samples. The relatively accessible and straightforward determination of the biogenic amines in wine has been made possible by using the photometric method developed for this purpose. Apart from its demonstrated application, i.e. assessment of wine's sanitary quality, it could be used in a wide range of investigations into food quality and freshness. It is easily quantifiable, and more accessible to end-user as compared to other methods used for this purpose.

The comprehensive analytical solution comprised of the experimental setup for smartphone-based analysis and a set of methods for the determination of multiple bioactive compounds is a novel tool for wine quality assessment. It can also be used as a development platform for dedicated, case-specific and cost-effective commercial solutions for food quality monitoring. The portability of the setup and simplification of sample



preparation procedures enable not only in-field use but also application in each stage of the manufacturing and distribution process.

In the study described in *preprint 2023*, it was demonstrated that the approach to the development of novel analytical methods for wine analysis, outlined in this thesis, is a valid proposition. The development of the solution described in this work required a multidisciplinary approach. It involved the identification of methodological difficulties related to smartphone application as a means of food analysis and the design of a well-functioning experimental setup aimed at overcoming them. Development of experimental setup for smartphone-based analysis involved knowledge concerning different polymers and their potential health effects. It involved working knowledge of chemometrics, e.g. during the application of the Design of Experiment and interpretation of the measurements made using a smartphone. The development of green, accessible analytical methods, which can be easily used outside the laboratory setting required practical knowledge of stipulations of green and sustainable chemistry. Finally, the smartphone-based determination of biogenic amines and other bioactive compounds in wine samples involved competence in modern analytical chemistry.

The results of these investigations were published in journals devoted to analytical chemistry (Analytical Methods, Current Opinion in Green and Sustainable Chemistry), and food science (Food Chemistry, Trends in Food Science and Technology). This demonstrates the wide topical range of studies that had to be conducted in order to complete the research goals of this work. All that has been successfully integrated to produce a comprehensive solution for wine analysis involving the use of smartphone and novel methods, with a demonstrated application potential. It highlights the potential of smartphone-based analysis of food in general and wine in particular.

## **5. Publications**

### **5.1. Paper 1: Chemometrics approaches to green analytical chemistry procedure development**

Kalinowska, K., Bystrzanowska, M., Tobiszewski, M., Chemometrics approaches to green analytical chemistry procedure development (2021) *Current Opinion in Green and Sustainable Chemistry*, 30, 100498, DOI: 10.1016/j.cogsc.2021.100498.





# Chemometrics approaches to green analytical chemistry procedure development

Kaja Kalinowska, Marta Bystrzanowska and Marek Tobiszewski

Chemometric tools are widely used in analytical chemistry for the reduction of data dimensionality, grouping of variables, and processing of analytical signals. They have also the potential to be applied in analytical procedure development with the aim of minimizing the procedure's environmental impact. The design of experiment gives the possibility to obtain much better information on the system response than in the case of 'changing one variable at a time' approach. This results in materials and energy savings. Desirability functions applied together with the design of experiment create a possibility to include in procedure development the variables that directly refer to the procedure's greenness. In this way, analysis time, consumption of solvents or reagents, and mobile phase (in the case of liquid chromatography) can be minimized. Cluster analysis and principal component analysis are successfully applied to find greener solvent alternatives.

## Addresses

Department of Analytical Chemistry, Faculty of Chemistry and EcoTech Center, Gdańsk University of Technology (GUT), 11/12 G. Narutowicza St., 80-233 Gdańsk, Poland

Corresponding author: Tobiszewski, Marek ([marek.tobiszewski@pg.edu.pl](mailto:marek.tobiszewski@pg.edu.pl))

Current Opinion in Green and Sustainable Chemistry 2021, 30:100498

This reviews comes from a themed issue on **Green Analytical Chemistry 2021**

Edited by **Mihkel Koel** and **Mihkel Kaljurand**

Available online 09 April 2021

For complete overview of the section, please refer the article collection - **Green Analytical Chemistry 2021**

<https://doi.org/10.1016/j.cogsc.2021.100498>

2452-2236/© 2021 Elsevier B.V. All rights reserved.

## Introduction

Chemometric tools are widely used in analytical chemistry to group objects and variables, categorize them, predict characteristics, and reduce the dimensionality of data sets for their easier evaluation. They are widely applied at the data treatment stage in the characterization of environmental media [1], food products (especially for their authentication) [2], or at the stage of signal processing [3,4].

Green analytical chemistry is aimed at the reduction of environmental and human health impacts related to analytical processes [5]. These goals are reached by the application of different strategies, such as using direct analytical methodologies [6], solventless extraction techniques [7], microextraction techniques [8], the application of greener mobile phases, and their lower volumes in liquid chromatography (LC) [9] among many others. In this context, the application of chemometric techniques and related numerical tools is rather overlooked in the scientific literature. The good examples of previous contributions dealing with this problem can be the chapters published in the handbooks [10,11].

Green analytical chemistry by the definition is multivariate, so similar tools are required to describe this concept. Chemometric tools offer the possibility to reduce data dimensionality, the irrelevant variables or objects can be identified and further neglected. Chemometrics give a unique possibility to treat the data set as a whole, whereas traditional approaches treat the data set as a group of nonrelated variables of objects.

The aim of this paper is to present the chemometric applications for greener analytical chemistry. For this purpose, design of experiment, multi-objective procedure optimization, and optimal process parameter selections are summarized.

## Design of experiment

Experimental design or design of experiment (DoE) is quite widely applied in the optimization of analytical procedures, but it is rarely considered as useful in green analytical chemistry. Screening designs are useful as they allow to identify the factors that have the biggest influence on the response of the system. In this way, the material and energy savings are made by simply leaving the factors that do not influence analytical response without further interest [12]. Then, the number of experiments to be performed for three factors system is 8 when the factorial design is applied, 17 for application of Box–Behnken design, and 20 for central composite design [13]. After the application of factorial design, the response function is investigated to find the values of variables that are close to optimal.

Figure 1

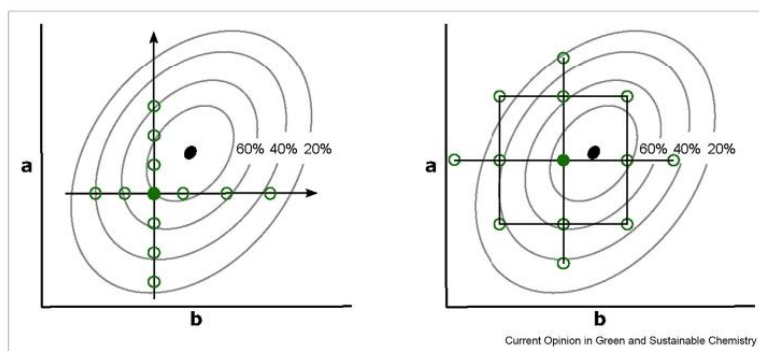

The response surface in case of change one at a time optimization (left) and design of experiment (right).

What is more, the application of DoE makes finding the optimal values more probable than changing one variable at a time approach. As it can be seen in Figure 1, the second approach does not cover the entire surface of variable range [14]. The same number of measurements results in obtaining better information on the system for DoE approach or fewer measurement points are needed to obtain the same information than it is in the case of changing one variable at a time approach. Changing both variables (or all included ones) seems to be a better approach.

DoE is also applied for screening the variables relevant to the optimization of the procedure. It results in time and materials savings as variables without impact (or with just small impact) on response are not considered. A good example can be the Plackett–Burman design that is applied for screening of variables to find significant ones that influence the performance of procedure for selenium species determination in water samples. After the reduction of variables by two, the remaining five are optimized with a central composite design [15]. Another example can be the optimization of the extraction procedure of phenols with deep eutectic solvents [16]. Only 17 runs are needed to optimize sample-to-solvent ratio, extraction time, and extraction temperature. Similarly, the reduction of initial seven variables to three (extraction solvent volume, agitation time, and buffer volume) can be done for dispersive liquid–liquid microextraction of fluconazole [17]. Then, optimization aims to obtain good recovery with minimized extraction solvent consumption.

LC conditions can also be optimized [18]. Two-level fractional factorial design is applied to screen for relevant parameters and Box–Behnken design to find optimal values of the separation process. Different responses are investigated, including resolution between

peaks, tailings of both peaks, run time and number of theoretical plates, analytical eco-scale and high-performance LC–environmental impact assessment scores. The responses of the system are investigated with overlay plots, which seem to be appropriate to treat 2–3 responses together but for more responses, other multiobjective optimization tools could be more appropriate.

### Multiobjective optimization

DoE even better fulfills the principles of green analytical chemistry if it is applied together with a multiobjective optimization method such as Derringer's desirability function [19]. In this function, the responses are transformed into individual desirabilities that are expressed in unitless 0–1 scale [20]. Typically in analytical chemistry, the responses of the system should be minimized or maximized, as presented in Figure 2.

After the calculation of individual desirabilities  $d_n$ , the global desirability  $D$  is calculated according to the following equation:

$$D = (d_1^{r_1} \times d_2^{r_2} \times \dots \times d_n^{r_n})^{1/n} \quad (1)$$

where  $r_1, r_2 (\dots) r_n$  are weights that express the relative importance of individual desirabilities. It should be noted that if any of the individual desirabilities equal 0, then the global desirability  $D$  also gives a nondesirable response.

The multiple variables to be optimized are typically chromatographic peak areas, peak resolutions, precision of responses, and also the time of chromatographic separation, which can be treated as green chemistry–related parameters [21,22]. Optimization of peaks resolution

Figure 2

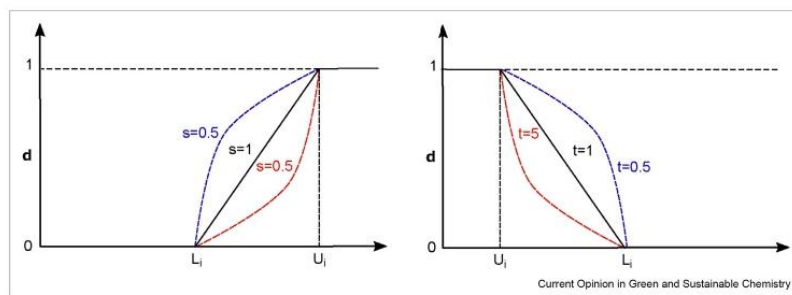

The transformation of values into individual desirabilities for the response that should be (a) maximized and (b) minimized.

and chromatographic separation is a very good example as general improvement of one variable can result in deterioration of performance of the second one. The resolution is variable to be maximized, whereas separation time is the variable to be minimized [23].

Six responses (LC separation time, tailing factors, and resolutions) are simultaneously optimized for the separation of active compounds and their impurities [24]. As tailing factors and resolutions are directly referring to the quality of separation, proper optimization of separation time can result in a decrease of mobile phase consumption, which is the green analytical chemistry parameter. Similarly, separation time and the resolutions for 16 analytes, that is, tryptophan derivatives are optimized with DoE and desirability function as well as a more suitable chromatographic column is selected [25]. The optimization of LC separation with desirability function is also done for non-steroidal anti-inflammatory drugs [26]. The responses considered are peak areas, resolutions, retention time of last eluting compound, and environmental impact of mobile phase (the function of volume and hazards).

Desirability functions can be applied in the development of green extraction procedures [27], by defining the responses of the system that refer to procedure greenness. It is done for the extraction of organophosphorus pesticides with magnetic solid-phase extraction [28]. The optimized parameters are responses for four analytes, equilibration time to be minimized, and pH value, salt content, and amount of sorbent to be in predefined ranges.

### Selection process conditions

One of the typical applications of chemometrics is a grouping of variables or objects [29], typically with cluster analysis or principal component (PC) analysis. Finding similar objects (of similar properties that are grouped) is a good clue in finding alternatives for a given

process. Such an approach can be applied to the selection of greener alternatives.

Sustainable Solvent Selection and Substitution (SUSSOL) tool is based on Kohonen self-organizing maps clustering of ~500 solvents that are based on their physicochemical properties [30]. The grouping is presented in Figure 3. Three groups are formed according to two dimensions. The dimension D1 is generally referred to as volatility with low boiling point solvents to the left, and D2 can be read as the measure of solvents polarity. After finding solvent substitutes with similar physicochemical properties, safety, health, and environment criteria are considered to select green solvent.

Another chemometric approach is based on a grouping of solvents according to physicochemical properties with cluster analysis [31]. In this study, three clusters are formed — polar, nonpolar, and volatile solvents, and the third cluster consists of nonpolar and rather nonvolatile solvents. Then for each cluster, ranking of solvents is performed with multicriteria decision analysis with several criteria describing solvents toxicity, degradation potentials, and safety of application. Cluster analysis is also used to calculate solvent similarity indexes [32]. With this tool, the substitutes for a given solvent or solvent mixture can be found based on the distance between solvents on the dendrogram obtained by the classification of 261 solvents.

The third similar approach incorporates PC analysis at the stage of a chemometric grouping of solvents [33]. The first six PCs carry the explanation power of 87.9% if the initial variability of the system PC1 represents the polarity variability of the solvents, PC2 the ability of the solvent to create a hydrogen bond. After finding the solvent on the PC1–PC2 plot (as the one explaining the biggest part of initial variability), the potential substitutes can be easily found as they are close neighbors. It is performed in user-friendly software.

Figure 3

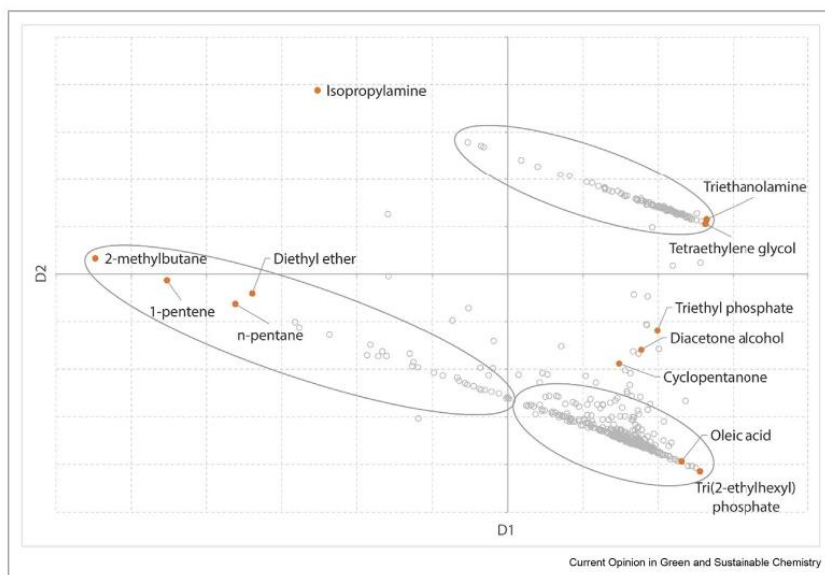

Grouping of solvents obtained with SUSSOL. The well-separated groups are formed. Reprinted from Ref. [28], licensed under a Creative Commons Attribution (CC BY) license.

All the three aforementioned examples show that a big enough data set of physicochemical properties describing organic solvents treated with unsupervised (the algorithm finds patterns in the data set without predefined assumptions) chemometric techniques nicely separate solvents according to volatility and polarity. As these two variables are typically the main descriptors during solvent selection for a given purpose, chemometric unsupervised classification can be very helpful to find greener alternative solvent of similar properties.

### Conclusions

The application of chemometrics in green procedure development is still limited. The examples shown in this contribution prove that the greenness of analytical procedure and the optimization process itself can be improved with the adaptation of chemometric tools. This can be obtained with a multivariate selection of greener solvents, application of DoE, and including greenness variables in multi-response optimization.

### Declaration of competing interest

The authors declare that they have no known competing financial interests or personal relationships that could have appeared to influence the work reported in this paper.

### Acknowledgements

This article is based upon work from the Sample Preparation Study Group and Network, supported by the Division of Analytical Chemistry of the European Chemical Society.

### References

Papers of particular interest, published within the period of review, have been highlighted as:

- \* of special interest
  - \*\* of outstanding interest
1. Dupont MF, Elbourne A, Cozzolino D, Chapman J, Truong VK, Crawford RJ, Latham K: **Chemometrics for environmental monitoring: a review**. *Anal Method* 2020, **12**:4597–4620. <https://doi.org/10.1039/d0ay01389g>.
  2. Reinholds I, Bartkevics V, Silvis IC, van Ruth SM, Esslinger S: **Analytical techniques combined with chemometrics for authentication and determination of contaminants in condiments: a review**. *J Food Compos Anal* 2015, **44**:56–72. <https://doi.org/10.1016/j.jfca.2015.05.004>.
  3. Kalogiouri NP, Aalizadeh R, Dasenaki ME, Thomaidis NS: **Application of High Resolution Mass Spectrometric methods coupled with chemometric techniques in olive oil authenticity studies-A review**. *Anal Chim Acta* 2020, **1134**:150–173. <https://doi.org/10.1016/j.aca.2020.07.029>.
  4. Salazar-Rojas D, Intilangelo A, Vignaduzzo SE, Maggio RM: **Development and validation of a green method for dissolution monitoring of pharmaceutical combinations. Meloxicam and pridinol**. *J Pharm Biomed Anal* 2019, **170**:228–233. <https://doi.org/10.1016/j.jpba.2019.03.038>.
  5. Koel M: **Do we need green analytical chemistry?** *Green Chem* 2016, **18**:923–931. <https://doi.org/10.1039/c5gc02156a>.
  6. Zivkovic S, Savovic J, Kuzmanovic M, Petrovic J, Momcilovic M: **Alternative analytical method for direct determination of Mn**



- and Ba in peppermint tea based on laser induced breakdown spectroscopy. *Microchem J* 2018, **137**:410–417. <https://doi.org/10.1016/j.microc.2017.11.020>.
7. Lorenzo-Parodi N, Kazir W, Stojanović N, Jochmann MA, Schmidt TC: **Solventless microextraction techniques for water analysis.** *Trends Anal Chem* 2019, **113**:321–331. <https://doi.org/10.1016/j.trac.2018.11.013>.
  8. Kokosa JM: **Advances in solvent-microextraction techniques.** *Trends Anal Chem* 2013, **43**:2–13. <https://doi.org/10.1016/j.trac.2012.09.020>.
  9. Welch CJ, Wu N, Biba M, Hartman R, Brkovic T, Gong X, Helmy R, Schafer W, Cuff J, Pirzada Z, Zhou L: **Greening analytical chromatography.** *Trends Anal Chem* 2010, **29**:667–680. <https://doi.org/10.1016/j.trac.2010.03.008>.
  10. Koel M, Kaljurand M: *Green analytical chemistry.* 2nd ed. Royal society of Chemistry; 2019.
  11. de la Guardia M, Garrigues S: *Challenges in green analytical chemistry*, vol. 2. Royal Society of Chemistry; 2020. <https://doi.org/10.1039/9781788016148>.
  12. Dejaegher B, Heyden YV: **Experimental designs and their recent advances in set-up, data interpretation, and analytical applications.** *J Pharmaceut Biomed Anal* 2011, **56**:141–158. <https://doi.org/10.1016/j.jpba.2011.04.023>.  
The paper is good introduction to types of experimental designs.
  13. Narendran ST, Meyyanathan SN, Karri VVSR: **Experimental design in pesticide extraction methods: a review.** *Food Chem* 2019, **289**:384–395. <https://doi.org/10.1016/j.foodchem.2019.03.045>.
  14. Hibbert DB: **Experimental design in chromatography: a tutorial review.** *J Chromatogr B* 2012, **910**:2–13. <https://doi.org/10.1016/j.jchromb.2012.01.020>.  
The paper discussed good practices in reporting DoE studies, software applied and different designs.
  15. Mostafavi B, Feizbakhsh A, Konož E, Faraji H: **Hydrophobic deep eutectic solvent based on centrifugation-free dispersive liquid–liquid microextraction for speciation of selenium in aqueous samples: one step closer to green analytical chemistry.** *Microchem J* 2019, **148**:582–590. <https://doi.org/10.1016/j.microc.2019.05.021>.
  16. Canales R, Espino M, Pasini S, Silva MF: **Chemometric and green metrics strategies for sustainable analytical methods: phenolic compounds in lettuce-NADES extracts.** *Anal Method* 2021. <https://doi.org/10.1039/d0ay02318c>.
  17. Moreira BJ, Schiave LA, Martinez R, Dias SG, de Gaitani CM: **Dispersive liquid–liquid microextraction followed by green high-performance liquid chromatography for fluconazole determination in cerebrospinal fluid with the aid of chemometric tools.** *Anal Method* 2020, **12**:3106–3114. <https://doi.org/10.1039/d0ay00704h>.
  18. Habib AA, Hammad SF, Megahed SM, Kamal AH: **Innovative quality by design approach for development of green micellar HPLC method for simultaneous determination of atorvastatin and amlodipine.** *Chromatographia* 2020, **83**:1221–1231. <https://doi.org/10.1007/s10337-020-03937-5>.  
The approach presented in this article includes green analytical chemistry metrics in procedure development. Environmental assessment tool and ecoscale scores are calculated for different HPLC conditions included in design of experiment.
  19. Candiotti LV, De Zan MM, Cámara MS, Goicoechea HC: **Experimental design and multiple response optimization. Using the desirability function in analytical methods development.** *Talanta* 2014, **124**:123–138. <https://doi.org/10.1016/j.talanta.2014.01.034>.
  20. Bezerra MA, Ferreira SLC, Novaes CG, Dos Santos AMP, Valasques GS, da Mata Cerqueira UMF, dos Santos Alves JP: **Simultaneous optimization of multiple responses and its application in Analytical Chemistry—A review.** *Talanta* 2019, **194**:941–959. <https://doi.org/10.1016/j.talanta.2018.10.088>.
  21. Hadjmohammadi MR, Nazari SSS: **Optimization of separation of flavonoids in micellar liquid chromatography using experimental design and Derringer's desirability function.** *J Liq Chromatogr Relat Technol* 2013, **36**:943–957. <https://doi.org/10.1080/10826076.2012.678458>.
  22. Hadjmohammadi M, Sharifi V: **Simultaneous optimization of the resolution and analysis time of flavonoids in reverse phase liquid chromatography using Derringer's desirability function.** *J Chromatogr B* 2012, **880**:34–41. <https://doi.org/10.1016/j.jchromb.2011.11.012>.
  23. Safa F, Hadjmohammadi MR: **Simultaneous optimization of the resolution and analysis time in micellar liquid chromatography of phenyl thiohydantoin amino acids using Derringer's desirability function.** *J Chromatogr A* 2005, **1078**:42–50. <https://doi.org/10.1016/j.chroma.2005.04.081>.
  24. Edrees FH, Saad AS, Alsaadi MT, Amin NH, Abdelwahab NS: **Experimentally designed chromatographic method for the simultaneous analysis of dimenhydrinate, cinnarizine and their toxic impurities.** *RSC Adv* 2021, **11**:1450–1460. <https://doi.org/10.1039/d0ra09585k>.
  25. Setyaningsih W, Saputro IE, Carrera CA, Palma M, Barroso CG: **Multiresponse optimization of a UPLC method for the simultaneous determination of tryptophan and 15 tryptophan-derived compounds using a Box-Behnken design with a desirability function.** *Food Chem* 2017, **225**:1–9. <https://doi.org/10.1016/j.foodchem.2016.12.034>.
  26. Dogan A, Tobiszewski M: **Optimization of liquid chromatographic separation of pharmaceuticals within green analytical chemistry framework.** *Microchem J* 2020, **152**:104323. <https://doi.org/10.1016/j.microc.2019.104323>.
  27. Bystrzanowska M, Tobiszewski M: **Multi-objective optimization of microextraction procedures.** *Trends Anal Chem* 2019, **116**:266–273. <https://doi.org/10.1016/j.trac.2018.12.031>.
  28. Heidari H, Razmi H: **Multi-response optimization of magnetic solid phase extraction based on carbon coated Fe<sub>3</sub>O<sub>4</sub> nanoparticles using desirability function approach for the determination of the organophosphorus pesticides in aquatic samples by HPLC–UV.** *Talanta* 2012, **99**:13–21. <https://doi.org/10.1016/j.talanta.2012.04.023>.
  29. Bystrzanowska M, Tobiszewski M: **Chemometrics for selection, prediction, and classification of sustainable solutions for green chemistry—a review.** *Symmetry* 2020, **12**:2055. <https://doi.org/10.3390/sym12122055>.
  30. Sels H, De Smet H, Geuens J: **SUSSOL—using artificial intelligence for greener solvent selection and substitution.** *Molecules* 2020, **25**:3037. <https://doi.org/10.3390/molecules25133037>.  
It is good presentation how chemometric tool can be applied in practice. The procedure to find alternative for N-methyl pyrrolidone is an example.
  31. Tobiszewski M, Tsakovski S, Simeonov V, Namieśnik J, Pena-Pereira F: **A solvent selection guide based on chemometrics and multicriteria decision analysis.** *Green Chem* 2015, **17**:4773–4785. <https://doi.org/10.1039/c5gc01615k>.
  32. Driver MD, Hunter CA: **Solvent similarity index.** *Phys Chem Chem Phys* 2020, **22**:11967–11975. <https://doi.org/10.1039/d0cp01570a>.
  33. Diorazio LJ, Hose DR, Adlington NK: **Toward a more holistic framework for solvent selection.** *Org Process Res Dev* 2016, **20**:760–773. <https://doi.org/10.1021/acs.oprd.6b00015>.

## **5.2. Paper 2: Smartphones as tools for equitable food quality assessment**

Kalinowska, K., Wojnowski, W., Tobiszewski, M., Smartphones as tools for equitable food quality assessment (2021) *Trends in Food Science and Technology*, 111, 271. DOI: 10.1016/j.tifs.2021.02.068



Contents lists available at ScienceDirect

## Trends in Food Science &amp; Technology

journal homepage: [www.elsevier.com/locate/tifs](http://www.elsevier.com/locate/tifs)

## Smartphones as tools for equitable food quality assessment

Kaja Kalinowska, Wojciech Wojnowski, Marek Tobiszewski\*

Department of Analytical Chemistry, Faculty of Chemistry, Gdańsk University of Technology (GUT), 80233, Gdańsk, Poland

## ARTICLE INFO

## Keywords:

Food quality and safety  
Biosensors  
Smartphone  
Equitable analytical chemistry  
On-site sensing

## ABSTRACT

**Background:** The ubiquity of smartphones equipped with an array of sophisticated sensors, ample processing power, network connectivity and a convenient interface makes them a promising tool for non-invasive, portable food quality assessment. Combined with the recent developments in the areas of IoT, deep learning algorithms and cloud computing, they present an opportunity for advancing wide-spread, equitable and sustainable food analytical methods that could be used at each stage of food production and distribution.

**Scope and approach:** This review focuses on the use of smartphone-based methods in food quality assessment and monitoring, with particular emphasis on the ones in which smartphones are used as detectors, either on their own or in conjunction with more elaborate analytical procedures. The role of these methods in common and equitable access to information on food quality is discussed, together with a consideration of the sustainability and greenness of the smartphone-based methods and a perspective on the methodology and validation. Additionally, recent developments and future research trends are also outlined.

**Key findings and conclusions:** Despite the persisting limitations resulting from technical difficulties and the complexity of the food sample matrix, smartphones will play an increasingly important role in popularizing the access to food analytical techniques for on-site analysis as a readily available and convenient integrated interface, connectivity and remote sensing platforms.

## 1. Introduction

The proliferation of smartphones equipped with relatively high-quality cameras has, in recent years, created entirely new possibilities for the wide-spread introduction of easily accessible tools for rapid quality assessment and quality assurance of food products ‘from farm to fork’ (see Fig. 1). In particular, the integration within the Internet of Things coupled with machine learning-based data processing and analysis tools might make tentative food quality tests truly and widely accessible to end-users, provided certain methodological difficulties are overcome. Such developments would be in line with the stipulations of green and equitable analytical chemistry (Chemat, Garrigues, & de la Guardia, 2019; Marcinkowska, Namieśnik, & Tobiszewski, 2019) which focus not only on reducing the environmental footprint of the analytical procedures but also on their widespread availability in terms of low price and applicability.

However, in many cases the implicit promise of using the smartphone’s camera for remote sensing is in reality far from being true. They are often used as convenient tools for data acquisition and processing and as a means of providing a graphic user interface in lieu of personal

computers, while still requiring the use of peripherals for the actual analysis. In other scenarios, the analytical procedure required to obtain a meaningful result is relatively elaborate and involves the use of instruments typically only found in laboratories. In particular, time-consuming and multi-stage sample preparation procedures might discourage potential end-users. Moreover, such complexity severely limits the practicality of the proposed solutions, especially in field conditions, and negates the main advantages of using smartphone-based techniques in the first place.

While it is important to account for the issues associated with the use of smartphone cameras themselves, such as white balance functions optimized by default for photography in bright ambient light and the inter-model transferability of colour readouts, it is crucial to also consider and validate the proposed procedures from the analytical and food chemistry perspective. The usability of smartphones for food quality assessment, not unlike any other analytical procedure, is contingent on the repeatability, selectivity and limit of detection (LOD) of the proposed methods (Nelis, Tsagkaris, Dillon, Hajslova, & Elliott, 2020). These issues are particularly important when considering matrices as complex as food. In order to develop practical solutions, it is

\* Corresponding author.

E-mail address: [marek.tobiszewski@pg.edu.pl](mailto:marek.tobiszewski@pg.edu.pl) (M. Tobiszewski).<https://doi.org/10.1016/j.tifs.2021.02.068>

Received 3 August 2020; Received in revised form 8 December 2020; Accepted 27 February 2021

Available online 5 March 2021

0924-2244/© 2021 The Authors. Published by Elsevier Ltd. This is an open access article under the CC BY license (<http://creativecommons.org/licenses/by/4.0/>).

necessary to rigorously validate the smartphone-based approaches, considering the matrix effect, sampling conditions, and not relying heavily on model or heavily spiked samples. This review is concerned with assessing the current status of the approaches to food quality assessment using smartphones and to clearly identify the current limitations and future trends and likely developments. A focus is placed on developments in which smartphones are used as detectors, either on their own or combined with more elaborate instrumental and sample preparation procedures. The role of smartphones in common and equitable access to information on food quality is discussed.

## 2. Equitable and sustainable analytical chemistry

When assessing smartphone-based food evaluation methods, it is important to consider whether the solution in question is in line with the stipulations of sustainable analytical chemistry (de la Guardia & Garrigues, 2011; Keith, Gron, & Young, 2007). The development of novel analytical tools necessarily entails the validation and optimization of the procedure (improving specificity, accuracy, LOD, etc.), as well as the economic aspects of the analysis. However, it is perhaps equally

important to consider the sometimes overlooked social and environmental aspects during the decision making and process development, which is the main idea behind the concept of sustainable chemistry (Marcinkowska et al., 2019). This social dimension is reflected by fair, common and equitable possibilities in obtaining information on purchased or stored food products quality. This ease of getting information can be assured with the development of analytical methodologies based on everyday devices, such as desktop scanners or more importantly smartphones.

It might be expected that the proliferation of smartphone-based personal food testing solutions involving e.g. the use of biosensors for quality assessment of food products might initially be limited to the developed countries. However, this likely will not be the case with food production. According to experts at FAO, family farms and small farms are responsible for over 80% of World's food production, and are estimated to constitute over 80% of World's farms overall (Lowder, Sánchez, & Bertini, 2019). The afore-referenced report calls for dedicating more attention to this category of farms and increasing their output as means for eradication of poverty, and indicates that technological progress is the determining factor in improving their

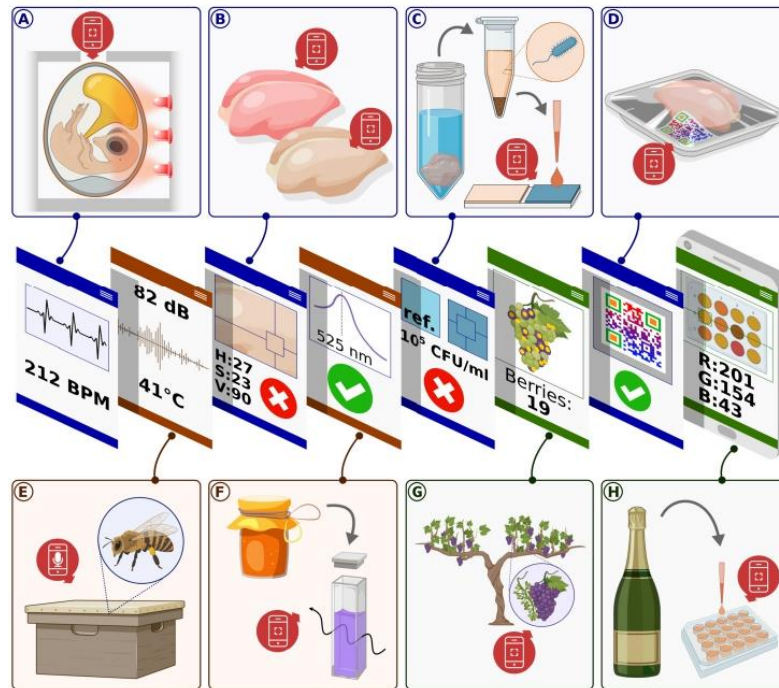

Fig. 1. Farm-to-fork use of smartphone-based food quality assessment tools.

- The viability and development of chicken embryos during artificial incubation may be measured in a non-invasive way by monitoring their heart rates using smartphones' video recording capabilities and an external red light source for photoplethysmography (A) (Phuphanin, Sampanporn, & Sutapun, 2019). During processing, the quality of the raw poultry meat, e.g. concerning the pale poultry syndrome, can be assessed by analysing its colour based on the analysis of pictures captured with the smartphone camera (B) (Barbin et al., 2016; You, Liu, Zhang, Xv, & He, 2020). The consumer's safety can be then assured prior to distribution, e.g. by testing for *salmonella* in chicken meat using magnetic particle immunoseparation-based biosensors in resource-scarce settings or as portable kits, with smartphones used for image analysis (C) (Guo et al., 2019), or during distribution and by the consumers themselves by scanning the colourimetric sensors imbedded in packaged poultry meat to detect the onset of spoilage (D) (Chen et al., 2017; Lee, Baek, Kim, & Seo, 2019; Rukchon, Nopwinyuwong, Trevanich, Jinkarn, & Suppakul, 2014).
- The beekeeper might monitor the hive microclimate and the thermal comfort of honeybees by detecting changes in the sound intensity level using the smartphone's built-in microphone (E) (Lima et al., 2019), while an opto-sensing accessory mounted on a smartphone and utilizing aptamer-conjugated gold nanoparticles for point-of-need safety inspection can be used to examine the concentration of streptomycin in honey (F) (Liu et al., 2017).
- Similarly, smartphone-based food quality assessment methods find application in wine production from the pre-harvest grapes inspection in the vineyard (G) (Ang, Seng, Oczkowski, Deloire, & Schmidtke, 2018; Aquino, Barrio, Diago, Millan, & Tardaguila, 2018) to detecting the deterioration of wine's organoleptic properties during ageing and storage by monitoring the browning process (H) (Pérez-Bernal, Villar-Navarro, Morales, Ubeda, & Callejón, 2017).

productivity. Since only approx. 2% of the farms are located in high-income countries (according to the World Bank (World Bank, 2017)), the effort to improve food production through technological innovation ought to be focused on developing countries. This seems to be the perfect use case for smartphone based food quality assessment, especially at the production and distribution stages, as their implementation could drastically improve the otherwise limited access to instrumental methods. For instance, while the machine learning-based methods for crop yield estimation might not be on par with industrial solutions used in extensive farming, they would be of great use in family farms in which the alternative would be to perform the assessment manually, or to dispense of it altogether. While the smartphone ownership in certain developing countries remains relatively low (e.g. 36% in Kenya and 32% in India (Schumacher & Kent, 2020)), it is increasing at a rapid pace, alongside with mobile network connectivity and bandwidth (Cisco Visual Networking Index: Global Mobile Data Traffic Forecast Update, 2017–2022, 2019).

The environmental impact of the implementation of an analytical method is often indirectly considered during the evaluation of its economic aspects, since certain decisions, such as e.g. reducing the amount of used reagents or increasing the sample throughput might both reduce the operating costs and minimize the environmental footprint (de la Guardia & Armenta, 2011). The issue of the environmental impact can, however, be tackled more directly and purposefully by implementing the stipulations of green analytical chemistry, notably its 12 principles (Gatuszka, Migaszewski, & Namieśnik, 2013). In the context of food analysis, this could entail for instance the monitoring of various production processes in order to evaluate whether unwanted and/or hazardous by-products are formed and by favouring analytical methodologies which do not adversely affect the analyst's health or the environment.

While the 'greenness' of analytical methods is increasingly being considered during their development (Aparecida de Marco, Saú Rechelo, Gandolpho Tótolí, Carolina Kogawa, & Regina Nunes Salgado, 2018; Gilbert-López, Mendiola, & Ibáñez, 2017; Pena-Pereira, Wojnowski, & Tobiszewski, 2020; Plotka-Wasyłka, 2018), their social dimension is often overlooked. One of the main tasks of analytical chemistry is to provide analytical information according to the requirements of end-users (Koel, 2016), which is particularly important in the context of food safety and quality control, where ideally the product should be tested by manufacturers, distributors and consumers to assure the latter's well-being. For this reason, analytical devices and the possibility of their use as well as the results of the measurements, should be accessible to everyone who may need them. In other words, emphasis should be put on the development of analytical methodologies that can be applied by non-trained users, preferably with the use of low-cost, readily available equipment. The ubiquity of smartphones, with their integrated and portable suite of features such as optical and other sensors, network connectivity, processing capabilities and, perhaps most importantly, familiar and accessible interface makes them the obvious choice when aiming at increasing the accessibility of food analytical methods (Grudpan, Kolev, Lapanantopakhun, McKelvie, & Wongwilai, 2015; Roda et al., 2016).

### 3. Smartphones: self-contained, mobile spectrometers

Perhaps the most intuitive application of smartphones in food quality assessment and monitoring would be to use them as mobile spectrometers, since nearly all currently marketed devices are equipped with complementary metal-oxide-semiconductor (CMOS) camera which could act as a detector, coupled with an integrated user interface and image processor. However, there are several factors to which one can attribute the lack of general-purpose smartphone-based spectrometers (Scheeline, 2016). Smartphones are not specifically designed as optical measuring instruments and their image sensors register polychromatic light which decreases the certainty of measurement and resolution

(Capitán-Vallvey, López-Ruiz, Martínez-Olmos, Erenas, & Palma, 2015). While on paper the sophisticated smartphone camera sensors with their >40-megapixel resolution (in some recent models up to 100-megapixel) seem more than sufficient for photometry, their performance is limited by the small pixel size and 8-bit digitization, which degrade the S/N ratio and precision. The latter will, however, be greatly improved, since smartphone models with 10-bit encoding are being introduced at the time of writing, effectively increasing the colour palette from  $256^3$  to  $1024^3$  colours (Tonelli et al., 2019), albeit at the cost of increased file size and computational effort. Still, the capabilities of most smartphone camera sensors are adequate for screening tests and field use (Scheeline, 2016), as evidenced by the number of reported possible applications (Aguirre, Long, Canals, & Cunningham, 2019; de Oliveira Krambeck Franco, Suarez, & Santos, 2017; Jung, Kim, Kim, & Bae, 2017; McGonigle et al., 2018; Patange, Mukundan, & Kumar, 2005; Rico-Yuste et al., 2016; Salinas et al., 2014; Scheeline, 2016; Song, Jiang, Wang, & Vincent, 2020; Ulrici, Foca, Ielo, Volpelli, & Lo Fiego, 2012). Another possible future improvement is broadening the sensor's response range. This could be achieved simply by removing the existing bandpass filters which limit the response only to the visible spectrum or by introducing additional ones, widening the range to between ~310 nm and ~900 nm (Wilkes et al., 2016). This would limit the camera's usefulness for conventional photography, but the manufacturers seem willing to equip the smartphones with as many as 5 or more rear-facing cameras, each with its sensor (Gartenberg, 2019), and so such development does not seem entirely unlikely. It would be particularly useful for non-invasive food content measurement – an application in which NIR spectrometry is already commonly used (Porep, Kammerer, & Carle, 2015). Extended, the analytically useful spectrum of radiation could be extended by using external UV light (Intaravanne, Sumriddetchkajorn, & Nukeaw, 2012), also for excitation in fluorescence-based tests (Feng et al., 2013).

Another factor limiting the proliferation of direct smartphone camera-based spectrometry in particular, and smartphone-based imaging in general, is the rapid pace of the development of new image sensors, which presents challenges for standardization (Ozcan, 2014). While most new smartphones now offer access to raw image format (RAW) files, and so to the signal from individual pixels, it should be remembered that proper colour calibration and white balancing is a challenge for professional photographers, and requires at a minimum the use of calibration cards or another reference. In the mid-2010s the reader would point to the possible solving of this issue through the imminent development of modular smartphones with the then ongoing projects such as Ara, Phoneblocks or RePhone (Hankammer, Jiang, Kleer, & Schymanietz, 2016, 2018). The latter could be even equipped with modules geared towards remote sensing, such as a UV sensor or a micro electro mechanical system (MEMS) gas sensor ("RePhone Introduction - Seeded Wiki," n.d.). The implementation of an array of metal-oxide-semiconductor field-effect transistor gas sensors in a replaceable module which could operate as an electronic nose, would have been a particularly useful development. This is because their use in smartphones, despite the small size and low power consumption, is limited by issues with long-term durability and signal stability (Wojnowski, Kalinowska, Majchrzak, Plotka-Wasyłka, & Namieśnik, 2019). However, some five years later these concepts have not gained sufficient traction to disrupt the industry. The issue of sensor readout equivalence will perhaps only be compounded by the manufacturers increasingly relying on computational photography for improving image quality, making them even more reluctant to open the access to back-end image processing protocols, and so the researchers instead turn to machine learning to tackle this problem (Abdalla, Cen, Abdel-Rahman, Wan, & He, 2019; Solmaz et al., 2018).

Apart from the camera, smartphones are also equipped with other sensors which could potentially find application in food quality assessment. A good example is the use of the built-in microphone to monitor the thermal comfort of honeybees. The intensity of the sound produced by the insects and registered using a smartphone was linked to the hive

microclimate which impacts the honey production and, more importantly concerning agricultural output, the foraging activity of the bees, leading to the pollination of crops (Lima et al., 2019). The device's microphone, in combination with its speaker, could also be used for ultrasonic sensing (Wang et al., 2019) which could be particularly useful for characterization and control of processes such as drying, emulsification, fermentation or crystallization (Mohd Khairi, Ibrahim, Md Yunus, & Faramarzi, 2015).

The current technical difficulties with realizing the smartphone-spectrometer concept in food analysis have led some to believe that the future trend will be to combine smartphones with inexpensive attachments with optics (Scheeline, 2016). Others, however, work on increasing the accessibility of food analytical chemistry through the integration of the already-existing methodologies with smartphone-based detector systems, as described in the following section.

#### 4. Smartphone-based biosensors

The integration of the already-existing methodologies for food analysis with smartphone-based detector systems is an interesting example of efforts to make food analytical chemistry more accessible. For instance, the coupling of various immunoassays and smartphones is gaining popularity in multiple fields of science. Methods in which the formation of a complex between the analyte and an antibody are used in order to achieve the detection, i.e. immunoassays, have gained vast popularity due to the simplicity of their use (Dixit & Twyman, 2019). Since the results can be expressed through the appearance of one or two

coloured lines (control line indicating correct functioning of the assay and, possibly, the test line indicating the presence of the analyte in question), they can be easily read even by a non-trained individual in a way not unlike the interpretation of pregnancy test results. While in some use cases the test's results can be evaluated using the naked eye, this approach is usually not sufficient in situations in which the results obtained using immunoassays are quantitative. This is where the coupling with smartphone-based detection systems facilitates the quantitation of the results, since the intensity of the test line's colour usually depends on the concentration of the analyte. Owing to the advances in smartphone imaging, it is possible to discriminate between colour intensities which would otherwise be indistinguishable to the human eye, especially after converting the colour space from red, green, blue (RGB) model to e.g. hue, saturation, intensity (HSI) colour model, where the intensity component can be easily isolated (see Figs. 1 and 2). For example, in the study of Li et al., latex microsphere immunochromatography was integrated with a smartphone-based device in order to perform a quantitative detection of zearalenone, mycotoxin often present in cereals and feed (Li et al., 2019). With the use of test strip, smartphone, a 3D-printed device with two lenses and *camera obscura* they obtained results highly consistent with the results obtained with both commercial kits and LC-MS/MS.

While paper-based reaction strips are seen as easy to use, even in the field or by untrained personnel, the same cannot be said about glass capillaries which are often used e.g. for the detection of contaminants. However, their fragility limits their usability in field applications. For instance, a smartphone attachment for *E. coli* detection in liquid samples based on quantum dot-based sandwich assays requires a rather

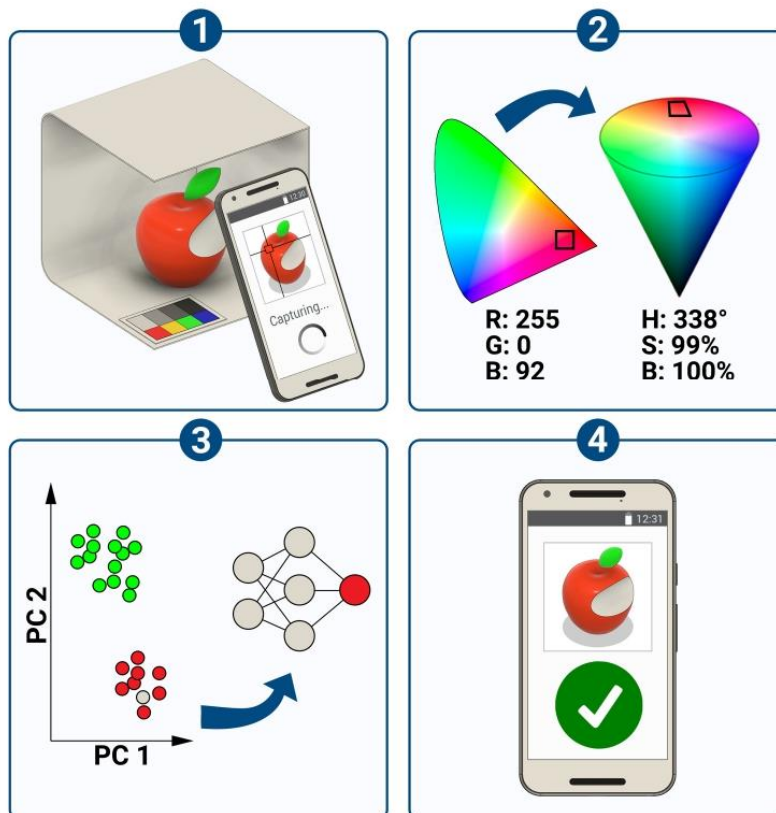

Fig. 2. A schematic representation of the approach to food quality assessment based on remote sensing with a smartphone camera: (1) capturing an image in a controlled environment, with reference colour values for calibration; (2) image processing: white balance, calibration, RAW conversion, colour space translation, etc.; (3) extraction and standardization of variables, followed by application of a machine learning model; (4) result expressed in a way convenient to the end-user. (For interpretation of the references to colour in this figure legend, the reader is referred to the Web version of this article.)

complicated sample preparation stage to perform the analysis (Zhu, Sikora, & Ozcan, 2012). The use of similar methods in the home setting is further complicated by the need to use equipment that is relatively difficult to obtain and might be too burdensome for someone with no laboratory experience. Since the capillary tubes used for the analysis can be secured within the device, they are far more useful in resource-limited environments compared to traditional capillary-based analytical methods, if not yet ready for home-use.

The ease of use is, however, of utmost importance in the various methodologies developed for the detection of allergens in food products in response to the emerging need, such as the smartphone-based quantum dots ratiometric fluorescence-sensing system for monitoring fluoroquinolone antibiotics in food samples (Ye et al., 2020), or the pocket-sized system utilizing a magneto-chemical sensor for the detection of antigens (Lin et al., 2017), shown in Fig. 3. The system consists of a pocket-sized detector, electrode and extraction kit that may be disposed of after use. Antigens are extracted from food as well as concentrated with the use of the kit and subsequently quantified using a keychain-sized reader in under 10 min. Since the cost of a single analysis is estimated by the authors to be lower than 4 \$, it represents a tangible step towards implementing the stipulations of equitable chemistry. The prototype system was tested for only five model antigens, and further research should be performed in order to assess the impact of various food processing techniques and matrix composition could have on extraction and detection of the analytes. However, it showcases the potential of placing smartphone-based biosensors in the hands of involved consumers.

In a similar approach, a smartphone-mounted tube reader was

developed for use in tandem with allergy test kits by measuring the absorption of colourimetric assays (Coskun et al., 2013). This application showcases the advantages of utilizing the intuitive and interactive smartphone GUI, guiding the untrained user through the steps required to perform the analysis using a user-friendly interface. This, combined with the possibility of uploading the test results to a dedicated server to build allergen maps, thus leveraging the inherent connectivity of smartphones, indicates the possibility of overcoming the difficulties outlined in Sections 3 and 6. Focusing on utilizing the numerous advantages of smartphones as platforms in which detection and communication capabilities are integrated with a convenient interface might bridge the gap in analytical capabilities between developed and developing countries. Solutions which, when implemented, could facilitate performing routine analyses in resource-scarce environments also include the smartphone-integrated rapid diagnostic tests (RDTs), like the ones used in medical diagnostics (Mudanyali et al., 2012). While these were not developed specifically for food safety assurance, they could be relatively easily geared towards detecting e.g. *E. coli* instead of *M. tuberculosis*. Some methods based on the use of smartphone biosensors, like the one developed for the determination of the phenol index using emulsification microextraction (Shahvar, Saraji, & Shamsaei, 2020) involve sample preparation stages, which might be either too complicated to be performed by untrained staff, or at least not practical in field conditions, as is the case with the method for allergen determination illustrated in Fig. 4. Nonetheless, they could nonetheless greatly improve the accessibility of food analytical methods.

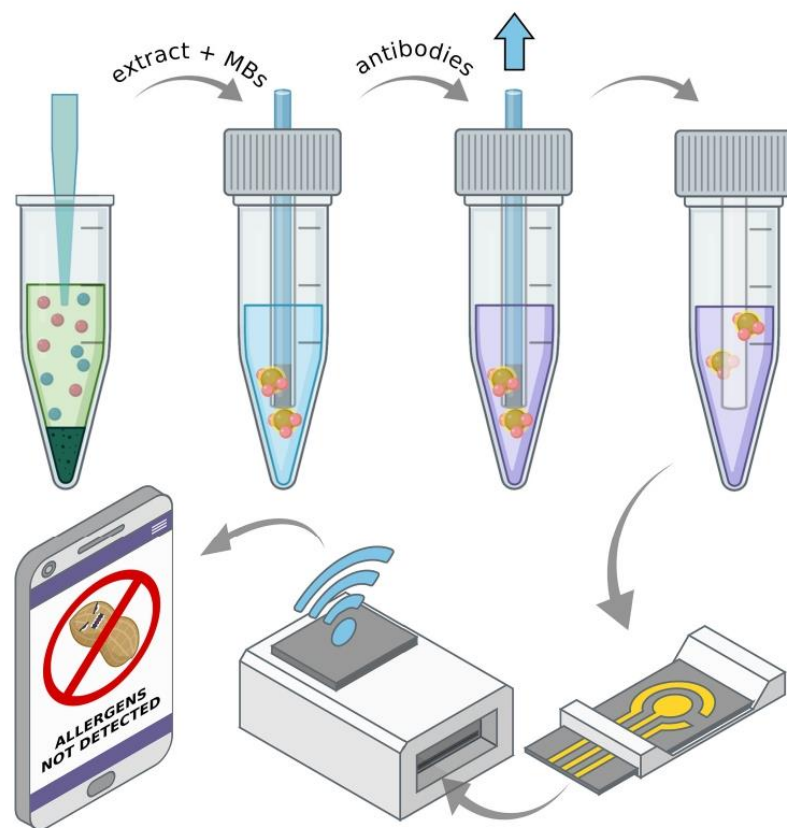

**Fig. 3.** A pocket-size system for antigen detection. Antigens are captured on magnetic beads (MBs) which are held in place during the extraction stage using a sheathed magnetic bar and subsequently labelled with antibodies conjugated with oxidizing agents. The MBs are then mixed with electron mediators and applied on an electrode which is then inserted into a reader which in turn transmits the data to a smartphone, allowing for data registration and system control. Adapted with permission from (Lin et al., 2017). Copyright 2017 American Chemical Society.

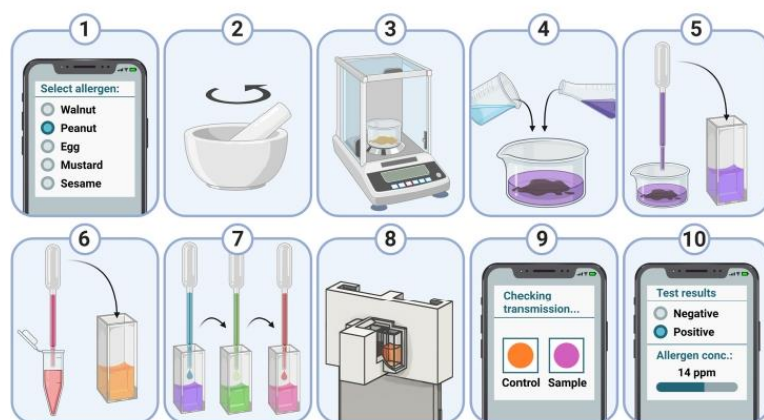

**Fig. 4.** Procedure for determination of allergens in food samples using a smartphone attachment and colourimetric assays: (1) the allergen of interest is selected in the application; (2) a food sample is finely ground; (3) approx. 5 g of the ground sample is transferred to a vessel; (4) the sample is mixed with water at 60 °C and with extraction solvent; (5) 3 drops of the sample solution is added to the first tube; (6) 3 drops of the control solution are added to the second tube which will act as reference; (7) following a 10 min incubation period, both the test and the control tubes are sequentially rinsed with a conjugate, substrate, and a stop solution, with a wash buffer used in between the rinses; (8, 9) absorbance of both solutions is measured using a dedicated smartphone attachment; (10) the test provides qualitative and quantitative information. Own rendering based on (Coskun et al., 2013).

## 5. Pattern recognition and machine learning

Apart from calibration in photometry- and colourimetry-based approaches to the quantification of colour images obtained using smartphone cameras, pattern recognition and image analysis finds application in food manufacturing and quality assessment based on images and videos captured using smartphone cameras. These include crop monitoring, e.g. through evaluating the number of grapevine berries in a grape (Aquino et al., 2018; Font et al., 2014), fruit sorting and grading (Álvarez-Bermejo, Morales-Santos, Castillo-Morales, Parrilla, & López-Ramos, 2019; Giraudo et al., 2018; Mizushima & Lu, 2013), identification of defects and assessing the fat content in meat products (Cruz-Fernández, Luque-Cobija, Cervera, Morales-Rubio, & de la Guardia, 2017; Ulrici et al., 2012). Such approach is to a lesser extent impacted by the device-dependent colour space representation (although it remains a problem, especially in light-dependent scenarios (Álvarez-Bermejo et al., 2019), since the classification and regression models might not be sufficiently robust to accommodate data collected under different conditions). The issues related to colour measurement and colour space conversion in the context of food quality control have been discussed by (Wu & Sun, 2013). Despite the recent developments in this area (Nixon & Aguado, 2020), extracting the features from images of food for the subsequent pattern recognition and machine learning remains a major issue (Zheng, Sun, & Zheng, 2006).

Other difficulties with the use of machine learning algorithms apply to both the pattern recognition and spectrometric applications of smartphone cameras. The more general the application, the greater the effort required to build a data library sufficiently large to train a robust machine learning model without the risk of overfitting. Such libraries, containing hundreds of thousands of reliably labelled objects, could likely only be built in collaboration with major stakeholders, i.e. big food manufacturers, who have at their disposal the necessary resources, infrastructure and procedures. The main incentive here could be the detection of adulterations (Song et al., 2020). On the other hand, the integration of smartphones with other sensor-equipped devices and communication networks within the IoT could, to some extent, democratize the process of data collection with the aim of building vast and robust machine learning libraries, on top of its other uses in food safety (Bouzembrak, Klüche, Gavai, & Marvin, 2019). While this would require some sort of incentive for e.g. manual classification of images, the necessary infrastructure is, on the most part, already in place, with ample processing power of the personal devices and 4G (soon to be 5G) network connectivity, with the notable exception of data storage which is likely to remain the bottleneck for the foreseeable future – an issue which would only be compounded by the increasing imaging

capabilities of smartphone cameras in the context of multi-sensor readouts, hyperspectral imaging and large image resolution.

## 6. The use of the smartphone camera instead of a detector – current issues and future perspectives

The accessibility and popularity of smartphones may significantly improve the applicability of biosensors since with their coupling it is possible to facilitate the monitoring of food quality throughout the entire production process. Most smartphone-based analytical methods can be used by both specialized personnel and non-trained consumers and thus, they could be routinely applied to monitor food quality at points of distinctive vulnerability, during all stages of production and distribution and, finally, at-home (Lu, Shi, & Liu, 2019). However, even though significant advances have been made in the area of portable and user-friendly analytical methodologies, a substantial amount of work is to be done before the ubiquitous use of the solutions proposed by researchers could be even considered. This is particularly true with regard to food quality assessment where extensive validation of the potential methodologies is of vital importance.

Numerous smartphone-based analytical solutions are evaluated with the use of model samples. While with this approach it is possible to estimate whether the concept behind the proposed methodology is not misguided, caution should be exercised when ascertaining whether the methodology in question can be applied in the analysis of real samples. This is particularly important with regards to food analysis – both because in case of food quality evaluation or e.g. allergens detection utmost precautions are required and due to the food itself being a very complex matrix. While the use of model samples is helpful during the method's development, it is difficult to assess the applicability of smartphone-based methodologies, be it at-home water quality analysis or the establishment of wells based on the sand samples evaluation, when they were tested solely on model samples (Iqbal & Bjorklund, 2011b). Moreover, even in the case where model solutions are made by adding the analyte to the commercially available product or otherwise prepared to maintain the similarity to the real samples, it still cannot be said that the conditions are identical to real-life analysis (as discussed in Section 3). As a result, the effectiveness of e.g. a smartphone-based method of coloured additives detection in real-life applications cannot be accurately evaluated since the aim of the preliminary research was to differentiate between samples of transparent soft drink to which ethyl red, reactive blue 2 or bromocresol green was added (Iqbal & Bjorklund, 2011a) which is only a rough approximation of the analysis of artificially coloured drinks that can be performed by the potential consumer. A similar case could be made with regard to e.g. the detection of



artificial sweeteners – while the subject is interesting and the proposed methodology may in future find its application in at-home food analysis, its relatively difficult to accurately assess its potential when it is used to detect sweeteners in blank tea solutions prepared in the laboratory and not in a commercially available soft drink which usually has a much longer ingredient list and is thus a far more complicated matrix (Musto, Lim, & Suslick, 2009). A similar problem may arise when pathogens' detection methods are assessed. While it is quite understandable, since obtaining commercially available food contaminated with pathogens might prove to be difficult, there is still room for improvement in the subject of the overall evaluation of these methodologies. Is the proposed approach specific for only one type of bacteria and does the presence of other species distort the obtained results? Is the recovery sufficient in different batches of the product? Does procuring foodstuff from various distributors impact the results? How does the method's limit of detection compare with reference methods? These are all important questions from the point of view of both researchers and industry representative who may be interested in the future implementation of these methods. While much consideration is given to these issues when novel smartphone-based methodologies are reported (de Oliveira Krambeck Franco et al., 2017; Silva & Rocha, 2020; Zeinhom et al., 2018; Zhu et al., 2012), the validation of new approaches has to become as thorough and commonplace as in other branches of food analysis for the smartphone-based techniques to reach maturity.

Several applications reviewed in this work featured components 3d-printed using the widely accessible fused deposition modeling (FDM) technology. This is further facilitated by the availability of freeware parametric design software allowing for easy tailoring of the CAD model to a particular smartphone. The possibility to couple the ease of on-site manufacturing of dedicated interfaces between the sample and the ubiquitous and increasingly powerful detector, i.e. the smartphone, will greatly increase the accessibility of basic food QA/QC methods.

This coupling between 3d-printing and smartphone detection could however be taken a step further. For some years now researchers have used stereolithography (STL) to produce intricate microfluidic devices - by all means miniaturised and sophisticated instruments for sample preparation and analysis (Cocovi-Solberg, Worsfold, & Miró, 2018). Until recently, there were no consumer-grade STL printers available at a price range which would make them a viable option for low-cost applications. However, this is no longer the case, and so it is likely that in the near future we shall see the development of applications involving parametrically customizable STL-printed microfluidic devices with smartphones used as detectors, especially in areas where the sample matrices are relatively complex, i.e. in food analysis and medical diagnostics.

## 7. Conclusions

This review covers the current trends in using smartphones for food quality assessment and how they might impact the accessibility of food analytical methods and their sustainability. The utility of using smartphones as an all-in-one data processing and user interface platform for food quality assessment is undeniable, especially with regard to lowering the cost of instrumental analytical methods and increasing the accessibility to food control procedures in the developing countries. This is even more true when considering making use of smartphones' integrated sensors as detectors, either on their own or in conjunction with straightforward sample treatment procedures. Here the recent developments are focused on using the increasingly sophisticated smartphone cameras at each stage of food production and distribution, from screening the raw materials to assessing the freshness of the product on the shelf. Providing the farmers and consumers alike with ubiquitous access to quality assessment tools literally in their pockets would greatly improve the public confidence in food safety. However, there remain unresolved technical difficulties with utilizing the smartphone camera as a mobile spectrometer without any accessories, stemming mostly

from difficulties with limiting the number of variables during measurement and lack of solutions for assuring the equivalence of measurements conducted using different device models and in different conditions. These difficulties are compounded by the fact that food is a particularly complex sample matrix, which is likely why the smartphone-based solutions for food quality assessment that might see widespread practical use in the nearest future involve the use of biosensors. Here the researchers can capitalize on the substantial advances in the fields of microfluidics and bioassays, such as the use of nanoparticles or quantum dots, to deliver targeted solutions (Cocovi-Solberg et al., 2018; Yang, Liu, & Jiang, 2019). This drastically increases the accessibility of analytical methods which would otherwise require costly equipment and infrastructure, thus promoting equitable analytical chemistry. Furthermore, it necessarily translates, through the miniaturization and reduction of the number of analytical steps in a procedure, to reduced consumption of samples and reagents, leading to the development of more green and sustainable analytical techniques.

While smartphone-based methods can be used in numerous areas of food evaluation, including quality assurance and assessment of authenticity, a majority of the reviewed solutions focuses on food safety monitoring and consumer-oriented detection platforms (Kalyani, Goel, & Jaiswal, 2020; Lu et al., 2019). Food safety and quality is a major concern for the consumers, who represent a sufficiently large group of stakeholders to possibly incite electronics manufacturers to consider their needs during hardware development, e.g. through increasing the remote sensing capabilities of the arrays of smartphone cameras. The ubiquity of such remote sensing capabilities could, combined with the integration of big data mining, cloud computing and deep learning made possible through the smartphones' inherent connectivity and developments in wireless networks and IoT, produce more generalized solutions for analysing a vast number of foodstuffs. This, however, presents a chicken-and-egg problem, and so it makes the widespread use of smartphone cameras as mobile spectrometers for food safety monitoring unlikely in the near future. However, it is clear that smartphones will play an increasingly important role in popularizing the access to food analytical techniques for on-site analysis as a readily available and convenient integrated interface, connectivity and remote sensing platforms.

## Declaration of competing interest

The authors declare that there is no conflict of interest.

## Acknowledgements

Elements of Figs. 1, 3 and 4 were created with BioRender.com.

## References

- Abdalla, A., Cen, H., Abdel-Rahman, E., Wan, L., & He, Y. (2019). Color calibration of proximal sensing RGB images of oilseed rape canopy via deep learning combined with K-means algorithm. *Remote Sensing*, 11(24), 3001. <https://doi.org/10.3390/rs11243001>
- Aguirre, M.Á., Long, K. D., Canals, A., & Cunningham, B. T. (2019). Point-of-use detection of ascorbic acid using a spectrometric smartphone-based system. *Food Chemistry*, 272, 141–147. <https://doi.org/10.1016/j.foodchem.2018.08.002>. April 2018.
- Álvarez-Bermejo, J. A., Morales-Santos, D. P., Castillo-Morales, E., Parrilla, L., & López-Ramos, J. A. (2019). Efficient image-based analysis of fruit surfaces using CCD cameras and smartphones. *The Journal of Supercomputing*, 75(3), 1026–1037. <https://doi.org/10.1007/s11227-018-2284-y>
- Ang, L.-M., Seng, K. P., Oczkowski, A., Deloire, A., & Schmidtkne, L. M. (2018). Development of a smartphone app for berry quality assessment. In P.-L. Teissedre, & L. Martínez (Eds.), *7th International Symposium "Opportunities and challenges for wine and vine production by preserving resources and environment"* (pp. 81–87). Retrieved from <https://www.waze.com/>.
- Aparecida de Marco, B., Saú Rechelo, B., Gandolpho Tófoli, E., Carolina Kogawa, A., & Regina Nunes Salgado, H. (2018). Evolution of green chemistry and its multidimensional impacts: A review. *Saudi Pharmaceutical Journal*. <https://doi.org/10.1016/j.jsps.2018.07.011>

- Aquino, A., Barrio, I., Diago, M. P., Millan, B., & Tardaguila, J. (2018). vitisBerry: An Android-smartphone application to early evaluate the number of grapevine berries by means of image analysis. *Computers and Electronics in Agriculture*, 148, 19–28. <https://doi.org/10.1016/j.compag.2018.02.021>. February.
- Barbin, D. F., Mastelini, S. M., Barbon, S., Campos, G. F. C., Barbon, A. P. A. C., & Shimokomaki, M. (2016). Digital image analyses as an alternative tool for chicken quality assessment. *Biosystems Engineering*, 144, 85–93. <https://doi.org/10.1016/j.biosystemseng.2016.01.015>
- Bouzenbrak, Y., Klüche, M., Gavai, A., & Marvin, H. J. P. (2019). Internet of Things in food safety: Literature review and a bibliometric analysis. *Trends in Food Science & Technology*, 94, 54–64. <https://doi.org/10.1016/j.tifs.2019.11.002>. October.
- Capitán-Vallvey, L. F., López-Ruiz, N., Martínez-Olmos, A., Erenas, M. M., & Palma, A. J. (2015, October 29). Recent developments in computer vision-based analytical chemistry: A tutorial review. *Analytica Chimica Acta*, 899, 23–56. <https://doi.org/10.1016/j.aca.2015.10.009>
- Chemat, F., Garrigues, S., & de la Guardia, M. (2019). Portability in analytical chemistry: A green and democratic way for sustainability. *Current Opinion in Green and Sustainable Chemistry*, 19, 94–98. <https://doi.org/10.1016/j.cogsc.2019.07.007>
- Chen, Y., Fu, G., Zilberman, Y., Ruan, W., Ameri, S. K., Zhang, Y. S., et al. (2017). Low cost smart phone diagnostics for food using paper-based colorimetric sensor arrays. *Food Control*, 82, 227–232. <https://doi.org/10.5307/JBE.2017.42.4.330>
- Cisco Visual Networking Index. (2019). *Global mobile data traffic forecast update, 2017–2022*.
- Cocovi-Solberg, D. J., Worsfold, P. J., & Miró, M. (2018, November 1). Opportunities for 3D printed millifluidic platforms incorporating on-line sample handling and separation. *TRAC Trends in Analytical Chemistry*, 108, 13–22. <https://doi.org/10.1016/j.trac.2018.08.007>
- Coskun, A. F., Wong, J., Khodadadi, D., Nagi, R., Tey, A., & Ozcan, A. (2013). A personalized food allergen testing platform on a cellphone. *Lab on a Chip*, 13(4), 636–640. <https://doi.org/10.1039/c2lc41152k>
- Cruz-Fernández, M., Luque-Cobija, M. J., Cervera, M. L., Morales-Rubio, A., & de la Guardia, M. (2017). Smartphone determination of fat in cured meat products. *Microchemical Journal*, 132, 8–14. <https://doi.org/10.1016/j.microc.2016.12.020>
- Dixit, C. K., & Twyman, R. M. (2019). Immunoassays, clinical applications. In *Encyclopedia of analytical chemistry* (pp. 8–14). Elsevier.
- Feng, L., Li, H., Niu, L. Y., Guan, Y. S., Duan, C. F., Guan, Y. F., et al. (2013). A fluorometric paper-based sensor array for the discrimination of heavy-metal ions. *Talanta*, 108, 103–108. <https://doi.org/10.1016/j.talanta.2013.02.073>
- Font, D., Pallejà, T., Tresanchez, M., Teixidó, M., Martínez, D., Moreno, J., et al. (2014). Counting red grapes in vineyards by detecting specular spherical reflection peaks in RGB images obtained at night with artificial illumination. *Computers and Electronics in Agriculture*, 108, 105–111. <https://doi.org/10.1016/j.compag.2014.07.006>
- Gartenberg, C. (2019, November 5). Xiaomi's first 108-megapixel cameraphone is here. *Verge*. Retrieved from <https://www.theverge.com/circuitbreaker/2019/11/5/20949438/xiaomi-cc9-pro-108-megapixel-camera-phone-samsung-sensor>.
- Galuszka, A., Migaszewski, Z., & Namieśnik, J. (2013). The 12 principles of green analytical chemistry and the SIGNIFICANCE mnemonic of green analytical practices. *Trends in Analytical Chemistry*, 50, 78–84. <https://doi.org/10.1016/j.trac.2013.04.010>
- Gilbert-López, B., Mendiola, J. A., & Ibáñez, E. (2017). Green foodomics. Towards a cleaner scientific discipline. *TRAC Trends in Analytical Chemistry*, 96, 31–41. <https://doi.org/10.1016/j.trac.2017.06.013>
- Giraud, A., Calvini, R., Orlandi, G., Ulrici, A., Geobaldo, F., & Savorani, F. (2018). Development of an automated method for the identification of defective hazelnuts based on RGB image analysis and colourgrams. *Food Control*, 94, 233–240. <https://doi.org/10.1016/j.foodcont.2018.07.018>. April.
- Grudpan, K., Kolev, S. D., Lapanantopakhun, S., McKelvie, I. D., & Wongwilai, W. (2015, May 1). Applications of everyday it and communications devices in modern analytical chemistry: A review. *Talanta*, 136, 84–94. <https://doi.org/10.1016/j.talanta.2014.12.042>
- de la Guardia, M., & Armenta, S. (2011). Origins of green analytical chemistry. *Comprehensive Analytical Chemistry*, 57(11), 1–23. <https://doi.org/10.1016/B978-0-444-53709-6.00001-X>
- Guardia, M. de la, & Garrigues, S. (2011). An ethical commitment and an economic opportunity. In M. de la Guardia, & S. Garrigues (Eds.), *Challenges in green analytical chemistry* (pp. 1–12). Royal Society of Chemistry.
- Guo, R., Wang, S., Huang, F., Chen, Q., Li, Y., Liao, M., et al. (2019). Rapid detection of Salmonella Typhimurium using magnetic nanoparticle immunoseparation, nanocluster signal amplification and smartphone image analysis. *Sensors and Actuators B: Chemical*, 284, 134–139. <https://doi.org/10.1016/j.snb.2018.12.110>. December 2018.
- Hankammer, S., Jiang, R., Kleer, R., & Schymanietz, M. (2016). From phonebloks to Google project Ara. A case study of the application of sustainable mass customization. *Procedia CIRP*, 51, 72–78. <https://doi.org/10.1016/j.procir.2016.04.157>
- Hankammer, S., Jiang, R., Kleer, R., & Schymanietz, M. (2018). Are modular and customizable smartphones the future, or doomed to fail? A case study on the introduction of sustainable consumer electronics. *CIRP Journal of Manufacturing Science and Technology*, 23, 146–155. <https://doi.org/10.1016/j.cirpj.2017.11.001>
- Intaravanne, Y., Sumriddechakajorn, S., & Nukeaw, J. (2012). Cell phone-based two-dimensional spectral analysis for banana ripeness estimation. *Sensors and Actuators B: Chemical*, 168, 390–394. <https://doi.org/10.1016/j.snb.2012.04.042>
- Iqbal, Z., & Björklund, R. B. (2011a). Assessment of a mobile phone for use as a spectroscopic analytical tool for foods and beverages. *International Journal of Food Science and Technology*, 46(11), 2428–2436. <https://doi.org/10.1111/j.1365-2621.2011.02766.x>
- Iqbal, Z., & Björklund, R. B. (2011b). Colorimetric analysis of water and sand samples performed on a mobile phone. *Talanta*, 54(4), 1118–1123. <https://doi.org/10.1016/j.talanta.2011.03.016>
- Jung, Y., Kim, H.-W., Kim, Y. H. B., & Bae, E. (2017). Design of smartphone-based spectrometer to assess fresh meat color. *Optical Diagnostics and Sensing XVII: Toward Point-of-Care Diagnostics*, 10072, 1007213. <https://doi.org/10.1117/12.2253414>. February 2017.
- Kalyani, N., Goel, S., & Jaiswal, S. (2020, September 9). On-site sensing of pesticides using point-of-care biosensors: A review. *Environmental Chemistry Letters*, 1, 3. <https://doi.org/10.1007/s10311-020-01070-1>
- Keith, L. H., Gron, L. U., & Young, J. L. (2007). Green analytical methodologies. *Chemical Reviews*, 107(6), 2695–2708. <https://doi.org/10.1021/cr068359e>
- Koel, M. (2016). Do we need green analytical chemistry? *Green Chemistry*, 18(4), 923–931. <https://doi.org/10.1039/c5gc02156a>
- Lee, K., Baek, S., Kim, D., & Seo, J. (2019). A freshness indicator for monitoring chicken breast spoilage using a Tyvek® sheet and RGB color analysis. *Food Packaging and Shelf Life*, 19, 40–46. <https://doi.org/10.1016/j.foodpsl.2018.11.016>. July 2018.
- Lima, M. V., De Queiroz, J. P. A. F., Pascoal, L. A. F., Saraiva, E. P., Soares, K. O., & Evangelista-Rodrigues, A. (2019). Smartphone-based sound level meter application for monitoring thermal comfort of honeybees *Apis mellifera* L. *Biological Rhythm Research*, 1–14. <https://doi.org/10.1080/09291016.2019.1616144>
- Lin, H. Y., Huang, C. H., Park, J., Pathania, D., Castro, C. M., Fasano, A., et al. (2017). Integrated magneto-chemical sensor for on-site food allergen detection. *ACS Nano*, 11(10), 10062–10069. <https://doi.org/10.1021/acsnano.7b04318>
- Liu, Z., Zhang, Y., Xu, S., Zhang, H., Tan, Y., Ma, C., et al. (2017). A 3D printed smartphone optosensing platform for point-of-need food safety inspection. *Analytica Chimica Acta*, 966, 81–89. <https://doi.org/10.1016/j.aca.2017.02.022>
- Li, X., Wang, J., Yi, C., Jiang, L., Wu, J., Chen, X., et al. (2019). A smartphone-based quantitative detection device integrated with latex microsphere immunochromatography for on-site detection of zearalenone in cereals and feed. *Sensors and Actuators B: Chemical*, 290, 170–179. <https://doi.org/10.1016/j.snb.2019.03.108>. February.
- Lowder, S. K., Sánchez, M. V., & Bertini, R. (2019). Farms, family farms, farmland distribution and farm labour: What do we know today?. Retrieved from [www.fao.org/publications](http://www.fao.org/publications).
- Lu, Y., Shi, Z., & Liu, Q. (2019). Smartphone-based biosensors for portable food evaluation. *Current Opinion in Food Science*. <https://doi.org/10.1016/j.cofs.2019.09.003>
- Marcinkowska, R., Namieśnik, J., & Tobiszewski, M. (2019, October 1). Green and equitable analytical chemistry. *Current Opinion in Green and Sustainable Chemistry*, 19, 19–23. <https://doi.org/10.1016/j.cogsc.2019.04.003>
- McGonigle, A. J. S., Wilkes, T. C., Pering, T. D., Willmott, J. R., Cook, J. M., Mims, F. M., et al. (2018). Smartphone spectrometers. *Sensors*, 18(1), 1–15. <https://doi.org/10.3390/s18010223>
- Mizushima, A., & Lu, R. (2013). An image segmentation method for apple sorting and grading using support vector machine and Otsu's method. *Computers and Electronics in Agriculture*, 94, 29–37. <https://doi.org/10.1016/j.compag.2013.02.009>
- Mohd Khairi, M. T., Ibrahim, S., Md Yunus, M. A., & Faramarzi, M. (2015). Contact and non-contact ultrasonic measurement in the food industry: A review. *Measurement Science and Technology*, 27(1). <https://doi.org/10.1088/0957-0233/27/1/012001>
- Mudanyali, O., Dimitrov, S., Sikora, U., Padmanabhan, S., Navruz, I., & Ozcan, A. (2012). Integrated rapid-diagnostic-test reader platform on a cellphone. *Lab on a Chip*, 12(15), 2678–2686. <https://doi.org/10.1039/c2lc40235a>
- Musto, C. J., Lim, S. H., & Suslick, K. S. (2009). Colorimetric detection and identification of natural and artificial sweeteners. *Analytical Chemistry*, 81(15), 6526–6533. <https://doi.org/10.1021/ac901019g>
- Nelis, J. L. D., Tsagaris, A. S., Dillon, M. J., Hajslova, J., & Elliott, C. T. (2020, August 1). Smartphone-based optical assays in the food safety field. *TRAC Trends in Analytical Chemistry*, 129, 115934. <https://doi.org/10.1016/j.trac.2020.115934>
- Nixon, M., & Aguado, A. (2020). *Feature extraction and image processing for computer vision. In feature extraction and image processing for computer vision* (4th ed.). <https://doi.org/10.1016/c2017-0-02153-5>
- de Oliveira Krambeck Franco, M., Suarez, W. T., & Santos, V. B. dos (2017). Digital image method smartphone-based for furfural determination in sugarcane spirits. *Food Analytical Methods*, 10(2), 508–515. <https://doi.org/10.1007/s12161-016-0605-4>
- Ozcan, A. (2014). Mobile phones democratize and cultivate next-generation imaging, diagnostics and measurement tools. *Lab on a Chip*, 14(17), 3187–3194. <https://doi.org/10.1039/c4lc00010b>
- Patange, S. B., Mukundan, M. K., & Kumar, K. A. (2005). A simple and rapid method for colorimetric determination of histamine in fish flesh. *Food Control*, 16(5), 465–472. <https://doi.org/10.1016/j.foodcont.2004.05.008>
- Pena-Pereira, F., Wojnowski, W., & Tobiszewski, M. (2020). AGREE – analytical GREEnness metric approach and software. *Analytical Chemistry*. <https://doi.org/10.1021/acs.analchem.0c01887>
- Pérez-Bernal, J. L., Villar-Navarro, M., Morales, M. L., Ubeda, C., & Callejón, R. M. (2017). The smartphone as an economical and reliable tool for monitoring the browning process in sparkling wine. *Computers and Electronics in Agriculture*, 141, 248–254. <https://doi.org/10.1016/j.compag.2017.07.029>
- Phuphanin, A., Sampanporn, L., & Sutapun, B. (2019). Smartphone-based device for non-invasive heart-rate measurement of chicken embryos. *Sensors*, 19(22), 1–14. <https://doi.org/10.3390/s19224843>
- Porep, J. U., Kammerer, D. R., & Carle, R. (2015, December 1). On-line application of near infrared (NIR) spectroscopy in food production. *Trends in Food Science & Technology*, 46, 211–230. <https://doi.org/10.1016/j.tifs.2015.10.002>

- Plotka-Wasyłka, J. (2018). A new tool for the evaluation of the analytical procedure: Green Analytical Procedure Index. *Talanta*, 181, 204–209. <https://doi.org/10.1016/j.talanta.2018.01.013>. January.
- RePhone Introduction - Seed Wiki (n.d.). Retrieved June 29, 2020, from <https://wiki.seedstudio.com/RePhone/>.
- Rico-Yuste, A., González-Vallejo, V., Benito-Peñ, E., Tomás De Las, T., Engel, C., Orellana, G., et al. (2016). Furfural determination with disposable polymer films and smartphone-based colorimetry for beer freshness assessment. <https://doi.org/10.1021/acs.analchem.6b00167>.
- Roda, A., Michelini, E., Zangheri, M., Di Fusco, M., Calabria, D., & Simoni, P. (2016, May 1). Smartphone-based biosensors: A critical review and perspectives. *TRAC Trends in Analytical Chemistry*, 79, 317–325. <https://doi.org/10.1016/j.trac.2015.10.019>
- Rukchon, C., Nopwinyuwong, A., Trevanich, S., Jinkarn, T., & Suppakul, P. (2014). Development of a food spoilage indicator for monitoring freshness of skinless chicken breast. *Talanta*, 130, 547–554. <https://doi.org/10.1016/j.talanta.2014.07.048>
- Salinas, Y., Ros-Lis, J. V., Vivancos, J. L., Martínez-Máñez, R., Aucejo, S., Herranz, N., et al. (2014). A chromogenic sensor array for boiled marinated Turkey freshness monitoring. *Sensors and Actuators B: Chemical*, 190, 326–333. <https://doi.org/10.1016/j.snb.2013.08.075>
- Scheeline, A. (2016, December 1). Cell phone spectrometry: Science in your pocket? *TRAC Trends in Analytical Chemistry*, 85, 20–25. <https://doi.org/10.1016/j.trac.2016.02.023>
- Schumacher, S., & Kent, N. (2020). Internet use around the world as countries grapple with COVID-19. Retrieved December 5, 2020, from Pew Research Center website <https://pewrsr.ch/2w0yAYy>.
- Shahvar, A., Saraji, M., & Shamsaei, D. (2020). Smartphone-based on-cell detection in combination with emulsification microextraction for the trace level determination of phenol index. *Microchemical Journal*, 154, 104611. <https://doi.org/10.1016/j.microc.2020.104611>. June 2019.
- Silva, A. F. S., & Rocha, F. R. P. (2020). A novel approach to detect milk adulteration based on the determination of protein content by smartphone-based digital image colorimetry. *Food Control*, 115, 107299. <https://doi.org/10.1016/j.foodcont.2020.107299>. March.
- Solmaz, M. E., Mutlu, A. Y., Alankus, G., Kılıç, V., Bayram, A., & Horzum, N. (2018). Quantifying colorimetric tests using a smartphone app based on machine learning classifiers. *Sensors and Actuators B: Chemical*, 255, 1967–1973. <https://doi.org/10.1016/j.snb.2017.08.220>
- Song, W., Jiang, N., Wang, H., & Vincent, J. (2020). Use of smartphone videos and pattern recognition for food authentication. *Sensors and Actuators B: Chemical*, 304, 127247. <https://doi.org/10.1016/j.snb.2019.127247>. October 2019.
- Tonelli, A., Candiani, A., Sozzi, M., Zucchelli, A., Foresti, R., Dall'Asta, C., et al. (2019). The geek and the chemist: Antioxidant capacity measurements by DPPH assay in beverages using open source tools, consumer electronics and 3D printing. *Sensors and Actuators B: Chemical*, 282, 559–566. <https://doi.org/10.1016/j.snb.2018.11.019>
- Ulrici, A., Foca, G., Ielo, M. C., Volpelli, L. A., Fiego, L., & Pietro, D. (2012). Automated identification and visualization of food defects using RGB imaging: Application to the detection of red skin defect of raw hams. *Innovative Food Science & Emerging Technologies*, 16, 417–426. <https://doi.org/10.1016/j.ifset.2012.09.008>
- Wang, Z., Hou, Y., Jiang, K., Dou, W., Zhang, C., Huang, Z., et al. (2019). Hand gesture recognition based on active ultrasonic sensing of smartphone: A survey. *IEEE Access*, 7, 111897–111922. <https://doi.org/10.1109/access.2019.2933987>
- Wilkes, T., McGonigle, A., Pering, T., Taggart, A., White, B., Bryant, R., et al. (2016). Ultraviolet imaging with low cost smartphone sensors: Development and application of a raspberry pi-based UV camera. *Sensors*, 16(10), 1649. <https://doi.org/10.3390/s16101649>
- Wojnowski, W., Kalinowska, K., Majchrzak, T., Plotka-Wasyłka, J., & Namieśnik, J. (2019). Prediction of the biogenic amines index of poultry meat using an electronic nose. *Sensors*, 19(7), 1580–1589. <https://doi.org/10.3390/s19071580>
- World Bank. (2017). World Bank country and lending groups. *World of Banking*, 1–8. Retrieved from <https://datahelpdesk.worldbank.org/knowledgebase/articles/906519>.
- Wu, D., & Sun, D. W. (2013). Colour measurements by computer vision for food quality control - a review. *Trends in Food Science & Technology*, 29(1), 5–20. <https://doi.org/10.1016/j.tifs.2012.08.004>
- Yang, M., Liu, Y., & Jiang, X. (2019, February 7). Barcoded point-of-care biosassays. *Chemical Society Reviews*, 48, 850–884. <https://doi.org/10.1039/c8cs00303c>
- Ye, Y., Wu, T., Jiang, X., Cao, J., Ling, X., Mei, Q., et al. (2020). Portable smartphone-based QDs for the visual onsite monitoring of fluorquinolone antibiotics in actual food and environmental samples. *ACS Applied Materials and Interfaces*, 12(12), 14552–14562. <https://doi.org/10.1021/acsami.9b23167>
- You, M., Liu, J., Zhang, J., Xv, M., & He, D. (2020). A novel chicken meat quality evaluation method based on color card localization and color correction. *IEEE Access*, 1–9. <https://doi.org/10.1109/access.2020.2989439>
- Zeinhom, M. M. A., Wang, Y., Sheng, L., Du, D., Li, L., Zhu, M. J., et al. (2018). Smart phone based immunosensor coupled with nanoflower signal amplification for rapid detection of Salmonella Enteritidis in milk, cheese and water. *Sensors and Actuators B: Chemical*, 261, 75–82. <https://doi.org/10.1016/j.snb.2017.11.093>
- Zheng, C., Sun, D. W., & Zheng, L. (2006, December 1). Recent developments and applications of image features for food quality evaluation and inspection - a review. *Trends in Food Science & Technology*, 17, 642–655. <https://doi.org/10.1016/j.tifs.2006.06.005>
- Zhu, H., Sikora, U., & Ozcan, A. (2012). Quantum dot enabled detection of Escherichia coli using a cell-phone. *Analyst*, 137(11), 2541–2544. <https://doi.org/10.1039/c2an35071h>

### **5.3. Paper 3: Green, simple analytical method for total biogenic amines content determination in wine using spectrophotometry**

Kalinowska, K., Tobiszewski, M., Green, simple analytical method for total biogenic amines content determination in wine using spectrophotometry (2023) *Food Chemistry*, 402, 134457. DOI: 10.1016/j.foodchem.2022.134457.



Contents lists available at ScienceDirect

## Food Chemistry

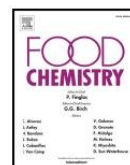
journal homepage: [www.elsevier.com/locate/foodchem](http://www.elsevier.com/locate/foodchem)

Short communication

## Green, simple analytical method for total biogenic amines content determination in wine using spectrophotometry

Kaja Kalinowska<sup>\*</sup>, Marek Tobiszewski

Gdańsk University of Technology, Faculty of Chemistry, Department of Analytical Chemistry, 11/12 Gabriela Narutowicza Street, 80-233 Gdańsk, Poland



## ARTICLE INFO

## Keywords:

Biogenic amines  
Spectrophotometry  
Design of Experiment (DoE)  
Wine analysis  
Greenness evaluation

## ABSTRACT

A simple, green and equitable procedure for total biogenic amines (BAs) content determination was developed. The scientific novelty lies in the use of commercially available S 0378 dye, the reaction of which with BAs results in a colour change of the solution. Sample preparation and analysis were simplified to make the method suitable for routine analyses even in resource-scarce settings. The optimization of the method was carried out using a Box-Behnken response surface design. The developed method has satisfactory figures of merit for putrescine equivalent determination with  $R^2$  in the range of 0.9906–0.9933 and recovery between 99.7 and 101.2%. The method's greenness was assessed using AGREEprep. Finally, wine samples were analysed to demonstrate the applicability of the developed method.

## 1. Introduction

Biogenic amines (BAs) play a key role in several physiological processes in plants, such as fruit and flower development and cell division (Karovicová & Kohajdová, 2005). However, since the high content of certain amines in food products can be the result of poor quality of raw materials, inadequate food processing, and contamination (Onal, 2007), the determination of BAs can give important information on spoilage and overall sanitary quality of food (Triki et al., 2018). Moreover, from the point of view of both consumer and producer, it is also important to monitor BAs concentration due to the fact that high levels of some, such as putrescine and cadaverine, can lower the sensorial quality of food. Because of numerous risks associated with the consumption of high amounts of BAs, the concentration of individual amines as well as total biogenic amines content in meat (Hernández-Jover et al., 1996; Wojnowski et al., 2019), fish (Tsai et al., 2006), beers (Kalac & Krizek, 2003), etc. has been extensively researched. However, these investigations were focused mostly on increasing the body of knowledge concerning the presence of biogenic amines in food and not on developing methods suitable for routine analyses. It is also worth noting that the current gold standards in the biogenic amines determination are various chromatography-based methods, which are relatively complicated, expensive and require skilful operators (Ahmad et al., 2020). Thus, the majority of the analytical methods for BAs determination is more suitable for laboratory use rather than for routine analysis in

industrial or retail settings.

While in the case of fish and fish products there are certain regulatory limits of e.g. histamine levels set by European legislation, there is no regulatory limit concerning the concentration of biogenic amines in wine (Visciano et al., 2014). However, monitoring the level of BAs is of particular importance in the case of wine and other alcoholic beverages, since the presence of ethanol and acetaldehyde might exacerbate the undesirable effect that amines can have on the quality and safety of food (Ancin-Azpilicueta et al., 2019). Because of that, the International Organization of Vine and Wine (OIV) recommends the reduction of BAs content in wine and other vine-based products (Ancin-Azpilicueta et al., 2019).

The aim of this study was to develop a simple, green and equitable procedure for total biogenic amines content determination that could be potentially used in routine wine analysis. The optimization of the method was carried out using the Design of Experiment (DoE). Then, the developed method was validated. The method's greenness was assessed using AGREEprep. Finally, red and white wine samples were analysed to demonstrate the applicability and validity of the developed methodology.

<sup>\*</sup> Corresponding author.

E-mail address: [kaja.kalinowska@pg.edu.pl](mailto:kaja.kalinowska@pg.edu.pl) (K. Kalinowska).

<https://doi.org/10.1016/j.foodchem.2022.134457>

Received 21 February 2022; Received in revised form 13 September 2022; Accepted 27 September 2022

Available online 29 September 2022

0308-8146/© 2022 The Authors. Published by Elsevier Ltd. This is an open access article under the CC BY license (<http://creativecommons.org/licenses/by/4.0/>).

## 2. Materials and methods

### 2.1. Reagents

Putrescine (PUT, 97.5 %) and triethylamine (TEA, 99.5 %) were purchased from Merck Life Science Sp. z o.o. (Merck, Poznań, Poland). The long-wavelength absorbing cyanine dye S 0378 ( $C_{37}H_{44}ClN_2NaO_6S_2$ ) was obtained from FEW Chemicals GmbH (Bitterfeld-Wolfen, Germany), while ethanol (EtOH, 99.8 %) was purchased from Avantor Performance Materials Poland (Gliwice, Poland). Ultrapure water for aqueous solutions and glassware washing was prepared using HLP5 Hydrolab demineralizer (Wiślina, Poland). A stock solution of putrescine (1.0 g/L) was prepared in ultrapure water, and the standard solution (0.5 g/l) was freshly prepared by diluting the stock solution.

### 2.2. Wine samples and preparation procedure

The non-filtered dry wine samples used in this work were commercially available and labelled as follows: BR (red, from Chile), GR (red, from Georgia), MR (red, from Uruguay), B (white, from Chile), M (white, from Uruguay), A (white, from New Zealand). Other wine characteristics, such as grape variety and alcohol content, are listed in Table S1. All wine samples were stored at room temperature, protected from light, and opened directly before the analysis.

All samples were analysed using the same protocol under optimized conditions. 1.6 mL of ethanol, 100  $\mu$ L of S 0378 solution (0.5 g/L) and 100  $\mu$ L of wine were mixed in a glass vial. 10  $\mu$ L of TEA was added, followed by filling the vial up to 2 mL with ultrapure water. The solution was then vortexed for 30 s at 2500 rpm. After that, the sample was placed in a water bath (70 °C) for 2 h. Finally, the sample was analysed using a spectrophotometer (Hach-Lange DR 3900, Colorado, United States) with absorbance measured at 650 nm. In cases where absorbance was higher than 1, samples were diluted 4-fold. Each sample was prepared in five replicates. Total biogenic amines content was then calculated as putrescine equivalent and expressed in mg PUT/L wine  $\pm$  standard deviation. A schematic representation of the method is shown in Fig. 1.

### 2.3. Optimization of the procedure

The novelty of the developed procedure lies in the application of the S 0378 dye. It reacts with primary amines according to the  $S_N1$  mechanism (Fig. 2) forming conjugate, which results in a visible change of solution's colour from green to blue (Gorris et al., 2011), with a maximum of the absorbance of resulting conjugate at 650 nm (Figure S2). The S 0378 dye was selected due to its proven ability to

react with biogenic amines as well as its excellent water solubility (Mobarez, Wongkaew, Simsek, Baeumner, & Duerkop, 2020).

The main parameters affecting the reaction of the S 0378 dye with biogenic amines are time and temperature of the reaction and type and volume of the solvent. Thus, it was decided to optimize them using a Design of Experiment. The experimental factors and factor levels were selected in preliminary studies based on the results of single-factor tests. Besides the above-mentioned factors, i.e. time, temperature, and type of solvent, it was decided to also assess the impact of the addition of TEA, since the use of triethylamine as a non-nucleophilic hydrogen chloride scavenger seems to make the formation of the amine-dye adduct more favourable.

The Response Surface Methodology (RSM) was used to evaluate the maximum efficiency of the S 0378 dye reaction with BAs in wine samples with the yield of the process expressed as the absorbance of the solution. The influence of four independent variables was assessed: the volume of ethanol (corresponding to 40–80 % of the total solution volume), trimethylamine volume (0–10  $\mu$ L), the temperature of the water bath (30–70 °C) and the reaction time (30–120 min). The design of experiment as well as the codes and levels of standardized variables are listed in Table S2.

### 2.4. Calibration curves and validation

Two different calibration curves of putrescine were prepared: 1–20 mg/L and 20–100 mg/L. The method described in 2.2 was then evaluated in accordance with quality assurance protocol, in which the following validation parameters were assessed: linearity, precision, sensitivity and accuracy. Description of the validation procedure can be found in Supplementary Materials.

### 2.5. Data analysis

The optimization of the sample preparation procedure was performed on wine samples enriched with putrescine (at 100  $\mu$ g/mL) using the response surface methodology (RSM) (Minitab 17, LLC, State College, Pennsylvania, USA). The design of experiment (DoE), namely the Box-Behnken design, was used to evaluate the optimal level and interaction effects of the four independent factors affecting the absorbance of the solutions. Factors in question were the volume of EtOH (99.8 %) solution [EtOH], the volume of trimethylamine (99.5 %) solution [TEA], time [Time] and temperature [Temperature] of the reaction. A total of 29 experiments (including 24 runs with factors examined at three levels (-1, 0, 1) and 5 centre points for the experimental error estimation) were carried out. The wine samples enriched with putrescine at 100  $\mu$ g/mL were analyzed in a randomized runs order. Three-dimensional response surface plots were generated in order to interpret the effects of four

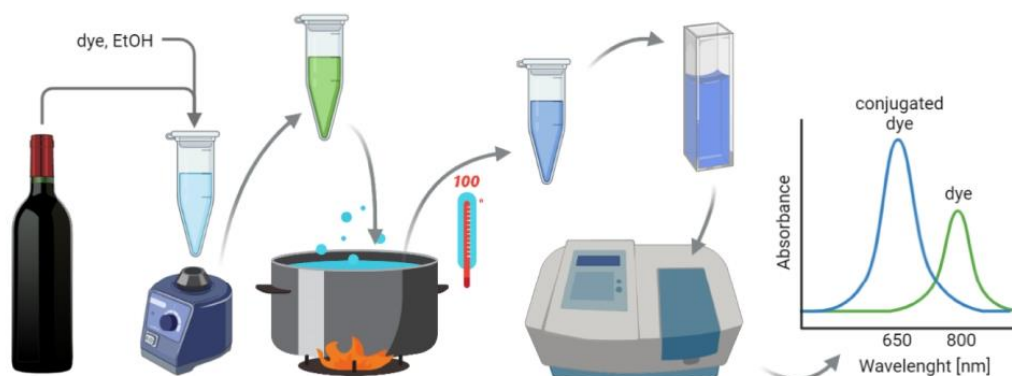

Fig. 1. Scheme of total biogenic amines content determination in wine samples.

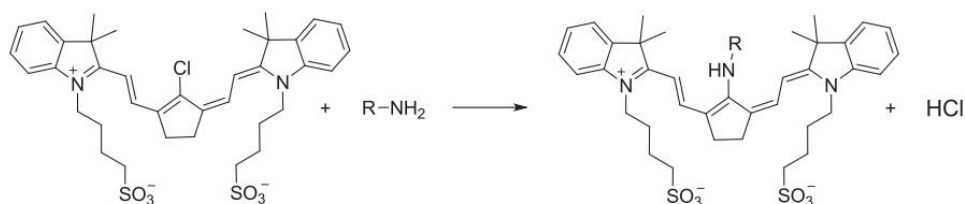

Fig. 2. Nucleophilic substitution of the S 0378 dye by a primary amine.

independent variables on the efficiency of S 0378 dye reaction with BA. RSM was applied for optimization of the sample preparation process. The regression coefficients of intercept, linear, quadratic, and interaction terms involved in the model and their effects were tested statistically at probability levels of  $p \leq 0.05$  using one-way analysis of variance (ANOVA). In order to optimize the processing conditions based on the model desirability features, graphical and numerical analyses were used.

### 3. Results and discussion

#### 3.1. Method optimization

The yield of the reaction of the S 0378 dye with primary amines was expressed as the absorbance of the solution (consisting of ethanol, water, TEA, S 0378 solution and spiked sample) in order to assess the maximum efficiency of the process. The resulting polynomial for estimating the absorbance of the solution based on EtOH and TEA content, time and temperature of the reaction is given in Equation 1:

$$\text{Absorbance} = 0.880 - 0.01034*[\text{EtOH}] - 0.0882*[\text{TEA}] - 0.0253*[\text{Temperature}] + 0.00129*[\text{Time}] - 0.000065*[\text{EtOH}]^2$$

$$\begin{aligned} & - 0.00347*[\text{TEA}]^2 + 0.000065*[\text{Temperature}]^2 - 0.000049*[\text{Time}]^2 \\ & + 0.000480*[\text{EtOH}]*[\text{TEA}] + 0.000270*[\text{EtOH}]*[\text{Temperature}] \\ & + 0.000030*[\text{EtOH}]*[\text{Time}] + 0.002325*[\text{TEA}]*[\text{Temperature}] \\ & + 0.000244*[\text{TEA}]*[\text{Time}] + 0.000101*[\text{Temperature}]*[\text{Time}] \end{aligned}$$

Based on the analysis of the  $p$ -values of each component of the model, it was possible to conclude that all four linear coefficients, three square coefficients ( $[\text{EtOH}]^2$ ,  $[\text{TEA}]^2$ ,  $[\text{Time}]^2$ ), and three two-way interaction coefficients ( $[\text{EtOH}]*[\text{TEA}]$ ,  $[\text{EtOH}]*[\text{Temperature}]$ ,  $[\text{TEA}]*[\text{Temperature}]$ ) were significant and indicative of a pattern of interactions between the studied variables.

The use of the Box-Behnken design resulted in six response surface plots for putrescine determination, which are graphical representations of the regression equation (Fig. 3). With the use of these plots, it is possible to visualize the relationship between the responses and the experimental parameter levels of variables, and the type of interaction between them.

All optimized parameters have a large impact on the efficiency of the reaction of the S 0378 dye with primary amines. The extraction

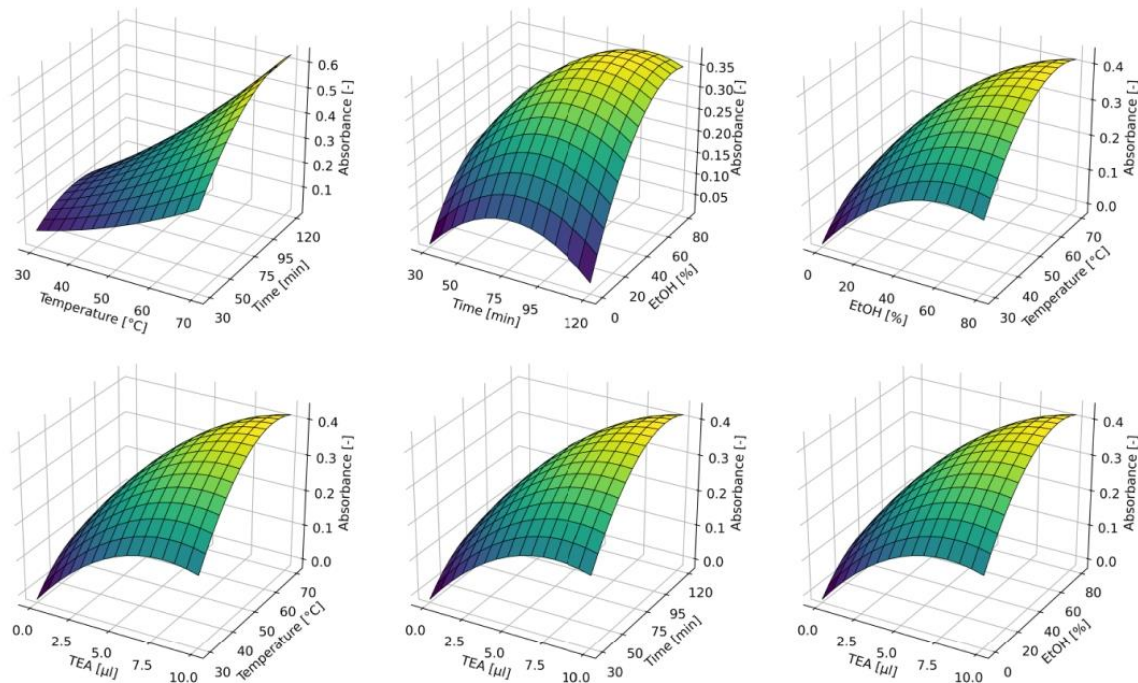

Fig. 3. Response surface plots of Box-Behnken DoE. The x and y-axis represent the variables, namely temperature, time, the volume of ethanol and trimethylamine, while the z is the standardized absorbance of the solution.

efficiency increased with the increase of all the parameters. The fact that absorbance is increasing in the whole range of selected parameters could suggest that the optimal values of the reaction's factors are not in the proposed ranges. The evaluated ranges of the continuous variables were selected based mostly on the preliminary studies, however, the value of the boundary conditions was also affected by practical limitations, e.g., the upper limit of the temperature range was set to not exceed the boiling point of the solvent. With the use of Box-Behnken design, it was possible to assess the impact of temperature, time as well as volume of TEA and EtOH and select their optimal values within these external constraints. Moreover, it was possible to significantly decrease the number of experiments and thus, reduce the impact of the optimization process on the environment.

### 3.2. Method validation

The method's linearity and sensitivity were assessed by calibration with standard solutions of putrescine. Different amounts of putrescine standard were added to wine in order to obtain 16 solutions with a concentration in two ranges (from 1 to 20 mg/L and from 20 to 100 mg/L), which were then subjected to the developed procedure. 1.6 mL of ethanol, 100  $\mu$ L of S 0378 solution (0.5 g/L), 10  $\mu$ L of TEA and 100  $\mu$ L of wine were mixed in a glass vial, which was then filled up to 2 mL with ultrapure water. The solution was then vortexed for 30 s at 2500 rpm, placed in a water bath (75 °C) for 2 h and then analysed using a spectrophotometer. Least squares linear regression was used to calculate the equations of the calibration curves and the determination coefficients ( $R^2$ ). Detailed information concerning analytical figures of merit is provided in Table 1. Good linearity at the wavelength of 650 nm was obtained for both ranges with a determination coefficient of 0.9906 for the first range and 0.9933 for the second range. Limits of detection and quantification were assessed based on the linear calibration equation and 10 blank samples. Calculations were made using the following equations:  $LOD = 3^*(\sigma/S)$  and  $LOQ = 10^*(\sigma/S)$ , where  $\sigma$  is the standard deviation and  $S$  is the slope of the calibration curve (Mörschbacher et al., 2018). Obtained limits of detection and quantification (0.29 and 0.98 mg/L for the first range) are higher than in the case of chromatography-based methods, where LOQ can range from 0.006 to 1.54 mg/L (Papageorgiou et al., 2018; Milheiro et al., 2019; Fabjanowicz et al. 2022). However, the aim of the study was to develop a procedure that will be simple and green, so that it can be applied for the routine analysis. Spectrophotometry is energy-efficient, the analysis takes only several seconds. What is more, the portability of the spectrophotometers as well as the ease of their use considerably facilitates on-site use. Developed method is also greener than chromatography-based methods, since the preparation of the samples is simplified and does not involve derivatization, which is potentially detrimental to the environment and the health of the analyst.

The accuracy of the method was determined by a recovery test. Results of the analysis of wine samples spiked with putrescine standard at two concentration levels ( $n = 7$ ; 7 and 15 mg/L for the first range, 50 and 70 mg/L for the second range) were compared with the concentration of spikes themselves. Recovery rates were  $99.7 \pm 2.0$  % for the range of 1–20 mg/L and  $101.2 \pm 3.5$  % for 20–100 mg/L, which indicates that the developed procedure for total biogenic amines content determination in wine samples is characterized by high accuracy.

The intra-day repeatability (RSD<sub>i</sub>) was estimated based on the results

of analysis of 7 replicates of wine samples fortified at two concentration levels (7 and 15 mg/L for the first range, 50 and 70 mg/L for the second range) on the same day. The inter-day repeatability (RSD<sub>R</sub>) was determined by analysis of samples from three different days over three weeks. RSD<sub>i</sub> ranged from 1.8 % to 1.9 %, while RSD<sub>R</sub> ranged from 1.7 % to 2.4 % (Table 1). Based on the results it can be concluded that biogenic amines are stable in the wine matrix and that the precision of the method is excellent.

### 3.3. Greenness evaluation

The developed analytical procedure for the determination of BAs in wine samples was subsequently assessed in terms of greenness using Analytical Greenness Metric for Sample Preparation (AGREEprep) (Wojnowski, Tobiszewski, Pena-Pereira, & Psillakis, 2022). To evaluate its environmental impact, the developed approach was juxtaposed with five other methods for BAs determination chosen from the literature. Three liquid chromatography-based methodologies were included in the greenness evaluation since LC-based methods are seen as the gold standard for BAs determination. Since in order to reduce the time of the analysis as well as its impact on the environment, high-performance liquid chromatography and ultra-high-performance liquid chromatography are often implemented in amines determination, methods based on them were also included in the analysis. In addition, the greenness of gas chromatography- and capillary electrophoresis-based methods was assessed as well.

As shown in Fig. 4, methodologies often used for biogenic amines determination produced results far from satisfactory in terms of greenness. This is caused mainly by the use of chromatography since it is not only time- and energy-consuming, but also must be preceded by complicated sample preparation procedure involving, amongst others, derivatization. The proposed method obtained scored significantly higher in the greenness metric, since the preparation of the samples is simplified and does not involve derivatization, which is detrimental not only to the environment but potentially also to the health of the analyst. Another advantage of the developed procedure is the use of spectrophotometry, given that it is energy-efficient and the analysis takes only several seconds. Moreover, the portability of the spectrophotometers as well as ease of their use considerably increases their equitability of the method and facilitates on site use.

### 3.4. Real samples analysis

The developed analytical method was used for putrescine equivalent determination in selected wines (Fig. 5). Six different wines (three white and three red) were analysed in five replicates using the proposed approach. The level of the total biogenic amines content was in a range of approx. 20–60 mg/L, which seems to be in accordance with information found in the literature (Papageorgiou et al., 2018). While there is no regulatory limit concerning the concentration of BAs in wine, there are regulations regarding histamine content in fish and fish-based products. Levels up to 200 mg/kg in fresh fish and 400 mg/kg in fishery products are deemed safe. It is worth noting, that in the case of wines, the total biogenic content is significantly lower than 200 mg/L (ranging from a few ng/L to 67 mg/L), which is why it was decided to evaluate the total biogenic amines content in lieu of histamine (Visciano et al., 2014; Martuscelli et al., 2013; Papageorgiou et al., 2018). What is

**Table 1**  
Validation parameters of developed methodology.

Concentration range [mg/L]	Linearity ( $R^2$ )	Intra-day repeatability (%RSD)		Recovery (%)	Inter-day repeatability (%RSD)		LOD [mg/L]	LOQ [mg/L]
1–20	0.9906	7 mg/L	15 mg/L	99.7 $\pm$ 2.0	7 mg/L	15 mg/L	0.29	0.98
		1.8	1.8		2.2	1.7		
20–100	0.9933	50 mg/L	70 mg/L	101.2 $\pm$ 3.5	50 mg/L	70 mg/L	1.4	4.5
		1.9	1.8		2.4	2.0		



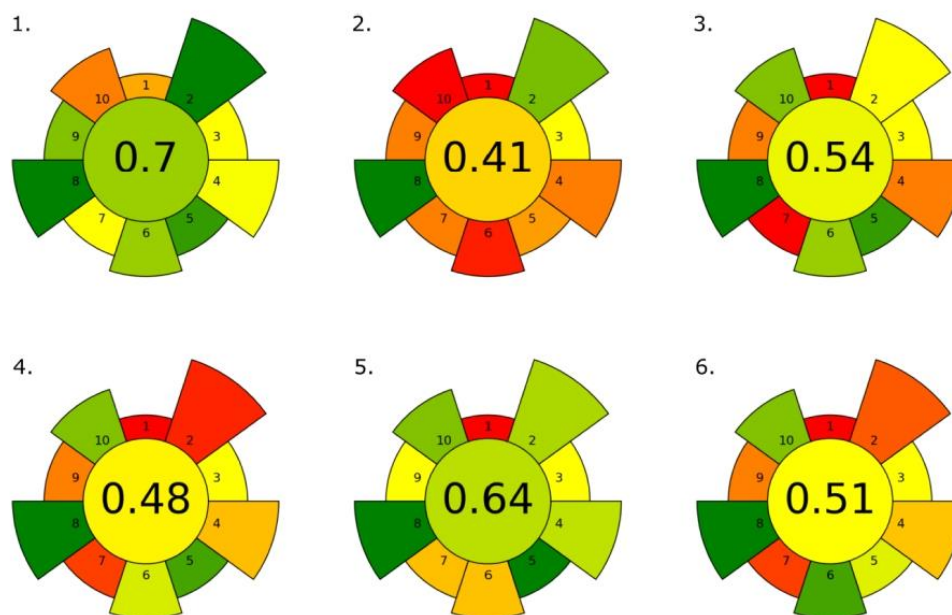

Fig. 4. Results of greenness evaluation of 6 analytical methodologies for BAs determination in wines: 1 – proposed procedure, 2 – DI-SPME-GC-MS (Papageorgiou et al., 2018), 3 – UPLC-MS/MS (Angulo et al., 2020), 4 – HPLC-PDA (Mitar et al., 2018), 5 – MEKC-LIF (Uzaşçı et al., 2012), 6 – SALLE-HPLC-FLD (Ramos et al., 2014). The higher the score, the greener the sample preparation method.

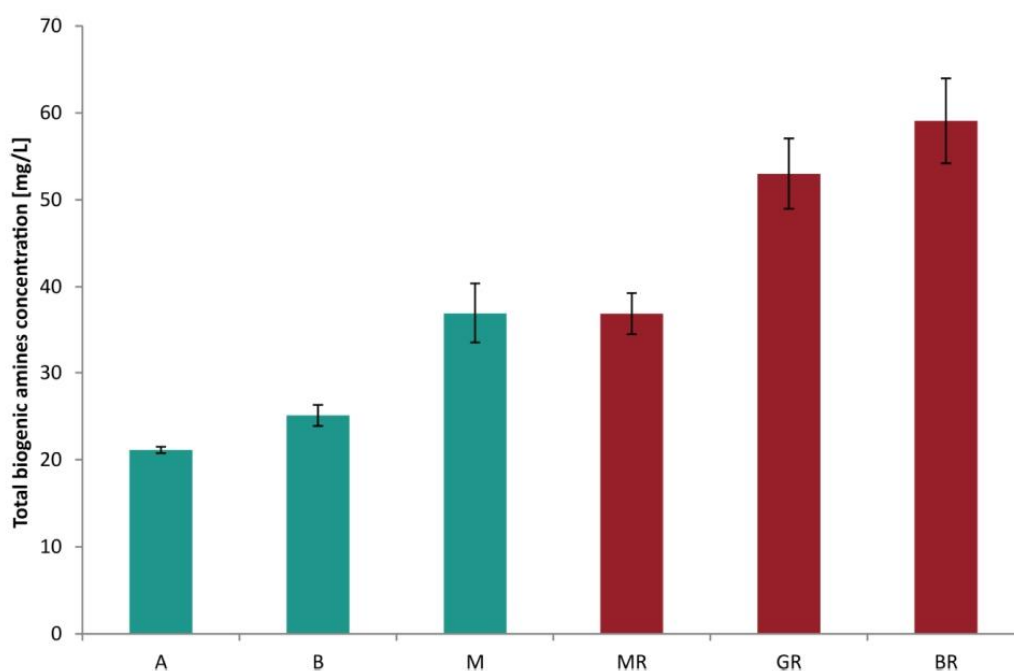

Fig. 5. Total biogenic amines concentration in red and white wines (depicted in burgundy and teal, respectively).

more, the concentration of BAs in red wines was higher than in white wines, which was to be expected since the process of their production differs (Guo et al., 2015). The highest concentration of biogenic amines

( $59.1 \pm 4.9$  mg/L) was found in the red wine from Chile (BR), while the lowest ( $21.14 \pm 0.36$  mg/L) in the white wine from New Zealand (A).

The use of spectrophotometry in the developed procedure facilitates



the process of total biogenic amines determination, which allows for fast, uncomplicated and cost-effective analysis. Furthermore, since the procedure involves only a few straightforward operations in the sample preparation step, it can be performed by people without prior analytical chemistry experience, which further increases the potential availability of the method. Thus, the application of the proposed procedure can significantly increase the sustainability and equitability of total biogenic amines determination.

#### 4. Conclusions

The majority of methods for biogenic amines determination in wine are chromatography-based and thus, are time- and resource-intensive, and have to be performed by a skilful operator. There is a lack of easy, straightforward methods for routine analysis, also in at-line and out of lab scenarios. The proposed method is aimed at filling this gap.

The developed procedure for total biogenic amines content in wine determination is simple to use and green. The use of spectrophotometry drastically increases the accessibility of the proposed procedure which would otherwise require educated operation, costly equipment and infrastructure, thus promoting equitable analytical chemistry. Simplification of the sample preparation stage translates, through the reduction of the number of analytical steps in a procedure, to reduced consumption of samples and reagents, resulting in a greener and more sustainable alternative to other analytical techniques for the determination of the total BAs content.

#### CRedit authorship contribution statement

**Kaja Kalinowska:** Conceptualization, Methodology, Investigation, Writing – original draft. **Marek Tobiszewski:** Writing – review & editing, Supervision.

#### Declaration of Competing Interest

The authors declare that they have no known competing financial interests or personal relationships that could have appeared to influence the work reported in this paper.

#### Data availability

Data will be made available on request.

#### Acknowledgements

The authors would like to thank TiM S.A. for providing the wine samples, Wojciech Wojnowski and Anna Różańska for assistance and support.

#### Appendix A. Supplementary data

Supplementary data to this article can be found online at <https://doi.org/10.1016/j.foodchem.2022.134457>.

#### References

- Ahmad, W., Mohammed, G. I., Al-Eryani, D. A., Saigl, Z. M., Alyoubi, A. O., Alwael, H., ... El-Shahawi, M. S. (2020). Biogenic amines formation mechanism and determination strategies: Future challenges and limitations. *Critical Reviews in Analytical Chemistry*, 50(6), 485–500. <https://doi.org/10.1080/10408347.2019.1657793>

- Ancin-Azpilicueta, C., Jiménez-Moreno, N., & Sola-Larrañaga, C. (2019). Wine. In C. Galankis (Ed.), *Innovations in Traditional Foods* (pp. 221–256). <https://doi.org/10.1016/B978-0-12-814887-7.00009-5>.
- Angulo, M. F., Flores, M., Aranda, M., & Henríquez-Aedo, K. (2020). Fast and selective method for biogenic amines determination in wines and beers by ultra high-performance liquid chromatography. *Food Chemistry*, 309, 125689–125695. <https://doi.org/10.1016/j.foodchem.2019.125689>
- Fabjanowicz, M., Różańska, A., Kalinowska, K., & Plotka-Wasyłka, J. (2022). Miniaturized, green salting-out liquid-liquid microextraction coupled with GC-MS used to evaluate biogenic amines in wine samples. *Microchemical Journal*, 180, 107616–107624. <https://doi.org/10.1016/j.microc.2022.107616>
- Gorris, H. H., Saleh, S. M., Groegel, D. B. M., Ernst, S., Reiner, K., Mustroph, H., & Wolfbeis, O. S. (2011). Long-wavelength absorbing and fluorescent chameleon labels for proteins, peptides, and amines. *Bioconjugate Chemistry*, 22(7), 1433–1437. <https://doi.org/10.1021/bc200192k>
- Guo, Y. Y., Yang, Y. P., Peng, Q., & Han, Y. (2015). Biogenic amines in wine: A review. *International Journal of Food Science and Technology*, 50(7), 1523–1532. <https://doi.org/10.1111/ijfs.12833>
- Hernández-Jover, T., Izquierdo-Pulido, M., Veciana-Nogués, M. T., & Vidal-Carou, M. C. (1996). Biogenic amine sources in cooked cured shoulder pork. *Journal of Agricultural and Food Chemistry*, 44(10), 3097–3101. <https://doi.org/10.1021/jf960250s>
- Kalac, P., & Krizek, M. (2003). A review of biogenic amines and polyamines in beer. *Journal of the Institute of Brewing*, 109(2), 123–128. <https://doi.org/10.1002/j.2050-0416.2003.tb00141.x>
- Karovićová, J., & Kohajdová, Z. (2005). Biogenic amines in food. *Chemical Papers*, 59(1), 70–79.
- Martuscelli, M., Arfelli, G., Manetta, A. C., & Suzzi, G. (2013). Biogenic amines content as a measure of the quality of wines of Abruzzo (Italy). *Food Chemistry*, 140(3), 590–597. <https://doi.org/10.1016/j.foodchem.2013.01.008>
- Milheiro, J., Ferreira, L., Filipe-Ribeiro, L., Cosme, F., & Nunes, F. (2019). A simple dispersive solid phase extraction clean-up/concentration method for selective and sensitive quantification of biogenic amines in wines using benzoyl chloride derivatisation. *Food Chemistry*, 274, 110–117. <https://doi.org/10.1016/j.foodchem.2018.08.116>
- Mitar, I., Ljubenković, I., Rohtek, N., Prkic, A., Andelic, I., & Vuletic, N. (2018). The content of biogenic amines in croatian wines of different geographical origins. *Molecules*, 23(10), 1–13. <https://doi.org/10.3390/molecules23102570>
- Mobarez, S. N., Wongkaew, N., Simsek, M., Baeumner, A. J., & Duerkop, A. (2020). Dipsticks with reflectometric readout of an nir dye for determination of biogenic amines. *Chemosensors*, 8(4), 1–16. <https://doi.org/10.3390/chemosensors8040099>
- Mörschbacher, A. P., Dullius, A., Dullius, C. H., Bandt, C. R., Kuhn, D., Brietzke, D. T., ... Hoehne, L. (2018). Validation of an analytical method for the quantitative determination of selenium in bacterial biomass by ultraviolet-visible spectrophotometry. *Food Chemistry*, 255, 182–186. <https://doi.org/10.1016/j.foodchem.2018.02.057>
- Önal, A. (2007). A review: Current analytical methods for the determination of biogenic amines in foods. *Food Chemistry*, 103, 1475–1486. <https://doi.org/10.1016/j.foodchem.2006.08.028>
- Papageorgiou, M., Lambropoulou, D., Morrison, C., Klodzińska, E., Namieśnik, J., & Plotka-Wasyłka, J. (2018). Literature update of analytical methods for biogenic amines determination in food and beverages. *Trends in Analytical Chemistry*, 98, 128–142. <https://doi.org/10.1016/j.trac.2017.11.001>
- Papageorgiou, M., Lambropoulou, D., Morrison, C., Namieśnik, J., & Plotka-Wasyłka, J. (2018). Direct solid phase microextraction combined with gas chromatography – Mass spectrometry for the determination of biogenic amines in wine. *Talanta*, 183, 276–282. <https://doi.org/10.1016/j.talanta.2018.02.006>
- Ramos, R. M., Valente, I. M., & Rodrigues, J. A. (2014). Analysis of biogenic amines in wines by salting-out assisted liquid-liquid extraction and high-performance liquid chromatography with fluorimetric detection. *Talanta*, 124, 146–151. <https://doi.org/10.1016/j.talanta.2014.02.026>
- Tsai, Y. H., Lin, C. Y., Chien, L. T., Lee, T. M., Wei, C. I., & Hwang, D. F. (2006). Histamine contents of fermented fish products in Taiwan and isolation of histamine-forming bacteria. *Food Chemistry*, 98(1), 64–70. <https://doi.org/10.1016/j.foodchem.2005.04.036>
- Uzaşçı, S., Başkan, S., & Erim, F. B. (2012). Biogenic amines in wines and pomegranate molasses-A non-ionic micellar electrokinetic chromatography assay with laser-induced fluorescence detection. *Food Analytical Methods*, 5(1), 104–108. <https://doi.org/10.1007/s12161-011-9220-6>
- Visciano, P., Schirone, M., Tofalo, R., & Suzzi, G. (2014). Histamine poisoning and control measures in fish and fishery products. *Frontiers in Microbiology*, 5(SEP), 10–13. <https://doi.org/10.3389/fmicb.2014.00500>
- Wojnowski, W., Kalinowska, K., Majchrzak, T., Plotka-Wasyłka, J., & Namieśnik, J. (2019). Prediction of the biogenic amines index of poultry meat using an electronic nose. *Sensors*, 19(7), 1580. <https://doi.org/10.3390/s19071580>
- Wojnowski, W., Tobiszewski, M., Pena-Pereira, F., & Psillakis, E. (2022). AGREEprep – Analytical greenness metric for sample preparation. *Trends in Analytical Chemistry*. <https://doi.org/10.1016/j.trac.2022.116553>, 116553.

## Supplementary Material

### Green, simple analytical method for total biogenic amines content determination in wine using spectrophotometry

Kaja Kalinowska\*, Marek Tobiszewski

*Gdańsk University of Technology, Faculty of Chemistry, Department of Analytical Chemistry  
11/12 Gabriela Narutowicza Street, 80-233 Gdańsk, Poland*

#### Validation description

Two different calibration curves were prepared: 1 – 20 mg/L and 20 – 100 mg/L. Linearity was assessed for both concentration ranges using 7 and 9 different concentrations, respectively. In order to estimate the sensitivity of the methodology, limits of detection (LODs) and limits of quantification (LOQs) were calculated based on the application of 10 replicates of blank samples and the minimum detectable analyte amount with a signal-to-noise ratio of 3 and 10, respectively, were estimated. The intra-day ( $RSD_i$ ) and inter-day ( $RSD_R$ ) precision were determined based on seven replicates of wine samples spiked at two levels for each range (7 and 15 mg/L for the range of 1 – 20 mg/L and 50 and 70 mg/L for 20 – 100 mg/L) and expressed as average relative standard deviation (RSD). Recovery rates were estimated using the calculated concentration of the samples of wine spiked with the known concentration of putrescine relative to the concentration of the spike itself (n=5).



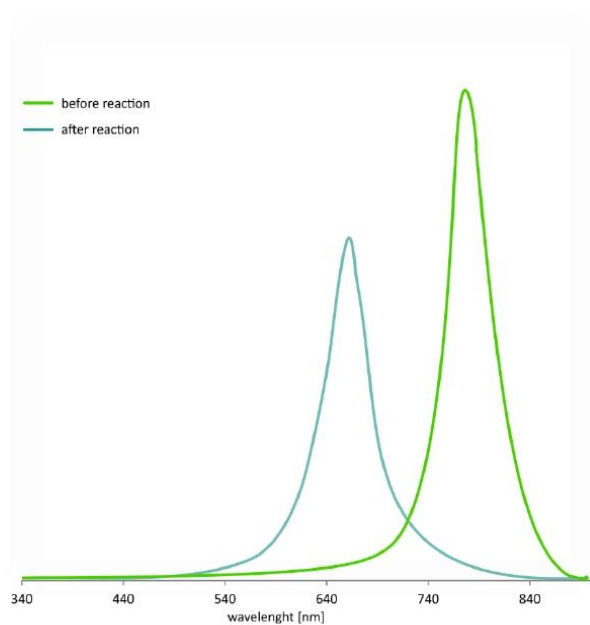

Figure S1. The absorbance of the dye before and after reaction with a primary amine.

Table S1. Wine samples characteristics.

Label	Wine type	Harvest year	Grape variety	Country of origin	Alcohol content
BR	Red	2019	Carmenere	Chile	13.5%
GR	Red	2019	Saperavi	Georgia	12.5%
MR	Red	2019	Tannat:Merlot (60:40)	Uruguay	12.5%
B	White	2019	Sauvignon Blanc	Chile	13.5%
M	White	2019	Chardonnay:Viognier (55:45)	Uruguay	13.0%
A	White	2019	Sauvignon Blanc	New Zealand	13.0%



Table S24. Box-Behnken response surface design along with corresponding values.

RunOrder	EtOH	TEA	Temp	Time	EtOH [%]	TEA [μL]	Temp [°C]	Time [min]	Standarized absorbance		
									Actual	Predicted	Residual
1	0	-1	0	-1	40	0	50	30	0.090	-0.025	0.115
2	1	1	0	0	80	10	50	75	0.042	-0.003	0.045
3	0	0	0	0	40	5	50	75	0.030	0.092	-0.062
4	0	0	-1	-1	40	5	30	30	0.365	0.498	-0.132
5	1	-1	0	0	80	0	50	75	0.031	0.062	-0.030
6	0	0	0	0	40	5	50	75	0.288	0.327	-0.039
7	0	0	1	-1	40	5	70	30	0.025	0.004	0.021
8	0	1	0	-1	40	10	50	30	0.647	0.634	0.013
9	1	0	0	-1	80	5	50	30	0.083	0.013	0.070
10	0	1	-1	0	40	10	30	75	0.104	0.118	-0.014
11	0	0	-1	1	40	5	30	120	0.037	0.028	0.009
12	-1	0	0	-1	0	5	50	30	0.276	0.351	-0.075
13	1	0	-1	0	80	5	30	75	0.000	0.124	-0.124
14	-1	0	-1	0	0	5	30	75	0.052	-0.032	0.084
15	0	1	1	0	40	10	70	75	0.018	0.107	-0.089
16	-1	0	1	0	0	5	70	75	1.000	0.88	0.120
17	-1	0	0	1	0	5	50	120	0.087	0.139	-0.052
18	0	0	0	0	40	5	50	75	0.022	-0.080	0.102
19	1	0	1	0	80	5	70	75	0.074	0.154	-0.079
20	-1	1	0	0	0	10	50	75	0.875	0.800	0.075
21	-1	-1	0	0	0	0	50	75	0.004	-0.018	0.022
22	0	0	0	0	40	5	50	75	0.171	0.181	-0.010
23	0	-1	0	1	40	0	50	120	0.030	-0.003	0.032
24	0	0	1	1	40	5	70	120	0.416	0.416	0.000
25	0	1	0	1	40	10	50	120	0.404	0.331	0.073
26	0	-1	1	0	40	0	70	75	0.291	0.331	-0.039
27	0	-1	-1	0	40	0	30	75	0.263	0.331	-0.068
28	0	0	0	0	40	5	50	75	0.36	0.331	0.029
29	1	0	0	1	80	5	50	120	0.336	0.331	0.005

#### **5.4. Paper 4: Simple analytical method for total biogenic amines content determination in wine using a smartphone**

Kalinowska, K., Wojnowski, W., Tobiszewski, M., Simple analytical method for total biogenic amines content determination in wine using a smartphone (2023) *Analytical Methods*, 15 (11), 1395. DOI: 10.1039/d2ay02035a.

Cite this: *Anal. Methods*, 2023, 15, 1395Received 16th December 2022  
Accepted 22nd February 2023

DOI: 10.1039/d2ay02035a

rsc.li/methods

## Simple analytical method for total biogenic amines content determination in wine using a smartphone

Kaja Kalinowska, \*<sup>a</sup> Wojciech Wojnowski <sup>ab</sup> and Marek Tobiszewski <sup>a</sup>

A simple, fast, and green smartphone-based procedure for total biogenic amines content determination in wine was developed and validated. Sample preparation and analysis were simplified to make the method suitable for routine analyses even in resource-scarce settings. The commercially available S0378 dye and smartphone-based detection were used for this purpose. The developed method has satisfactory figures of merit for putrescine equivalent determination with  $R^2$  of 0.9981. The method's greenness was also assessed using the Analytical Greenness Calculator. Samples of Polish wine were analysed to demonstrate the applicability of the developed method. Finally, results obtained with the developed procedure were compared with those previously obtained with GC-MS in order to evaluate the equivalence of the methods.

### 1. Introduction

Biogenic amines (BAs) are nitrogenous organic bases that play a key role in physiological processes in plants, such as fruit and flower development and cell division.<sup>1</sup> They are commonly found in food, particularly fermented products *e.g.* beer and wine. However, poor quality of raw materials, inadequate food processing, and microbial contamination can result in their increased content.<sup>2</sup> Because of that, the determination of BAs can give useful information on spoilage and the overall sanitary quality of food.<sup>3</sup> It is also vital to monitor BAs concentration due to the fact that high levels of amines can lower the sensorial quality of food and even cause several toxic effects (*e.g.* nausea, vomiting, diarrhoea, headache *etc.*).<sup>4</sup> In the case of alcoholic beverages, such as wine, this effect might be exacerbated due to ethanol and acetaldehyde presence.<sup>5</sup>

Wine analysis is a field which could significantly benefit from an increase in accessibility since the safety and quality of food should be meticulously monitored in order to ensure consumers' well-being. Because of that, emphasis should be put on the development of analytical methodologies that can be applied with the use of low-cost, readily available equipment, preferably by non-trained users.<sup>6</sup> Such development would be also in line with the stipulations of green and equitable analytical chemistry<sup>7,8</sup> which focus not only on the reduction of the environmental impact of the procedures but also on their low price, accessibility, and applicability.

Smartphones are gaining interest as promising tools for non-invasive, equitable food quality assessment. The utility of smartphones in food quality assessment lies mostly in reduction of the cost of the analysis and increasing the accessibility of analytical procedures for consumers, enabling them greater participation in the farm-to-fork QA/QC process.<sup>6,9</sup> However, there remain unresolved issues with implementing smartphone-based food analysis on a large scale that stem mostly from difficulties related to assuring the equivalence of measurements conducted *e.g.* using different device models, as well as from food being a particularly complex matrix. Nevertheless, the use of smartphones for food quality assessment remains one of the most promising routes for increasing accessibility of analytical chemistry to end-users, provided certain methodological difficulties are overcome.<sup>9,10</sup>

This study was aimed at developing a simple, fast, and green smartphone-based procedure for total biogenic amines content determination in wine. In order to facilitate the analysis of the results BAs content was expressed as putrescine equivalent ( $PUT_{eq}$ ), which is a common manner of expressing results of spectrophotometric measurements.<sup>11–13</sup> The developed method was validated and the method's greenness was subsequently assessed using the Analytical Greenness Calculator AGREE.<sup>14</sup> Various Polish wines were analysed to demonstrate the applicability of the developed methodology for the total BAs content assessment. Finally, results obtained with the developed

<sup>a</sup>Gdańsk University of Technology, Faculty of Chemistry, Department of Analytical Chemistry, 11/12 Gabriela Narutowicza Street, 80-233 Gdańsk, Poland. E-mail: kaja.kalinowska@pg.edu.pl

<sup>b</sup>University of Oslo, Department of Chemistry, P.O. Box 1033-Blindern, 0315 Oslo, Norway

## Analytical Methods

procedure were compared with those obtained with GC-MS in order to cross-validate the method.

## 2. Materials and methods

### 2.1. Reagents

Methylamine hydrochloride (MET, 98.0%), dimethylamine hydrochloride (DIMET, 99%), ethylamine hydrochloride (ET, 98%), diethylamine hydrochloride (DIET, 99%), propylamine (PROP, 98%), butylamine (BUT, 99.5%), isopentylamine (IPA, 98%), hexylamine (HEX, 99%), 2-phenylethylamine hydrochloride (2PEA, 98%), putrescine (PUT, 97.5%), cadaverine (CAD, 96.5%), histamine (HIS, 96.5%), tyramine (TYR, 96.5%), tryptamine (TRYP, 97.5%) as well as aniline (internal standard, IS, 99.5%) were purchased from Merck Life Science Sp. z o.o. (Merck, Poznań, Poland). Stock solutions of biogenic amines ( $1.0 \text{ g L}^{-1}$ ) and internal standard ( $1.0 \text{ g L}^{-1}$ ) were prepared in ultrapure water (HLP5 Hydrolab demineralizer, Wiślna, Poland), standard solutions were freshly prepared before application by diluting stock solution.

Triethylamine (TEA, 99.5%), and ethyl chloroformate (ECF, 99.5%) were also obtained from Merck Life Science Sp. z o.o. Ethanol (EtOH, 99.8%), sodium chloride (NaCl, ACS grade) and sodium hydroxide (NaOH, ACS grade) were purchased in Avantor Performance Materials (formerly POCH, Gliwice, Poland). The long-wavelength absorbing cyanine dye S0378 ( $\text{C}_{37}\text{H}_{44}\text{ClN}_2\text{NaO}_6\text{S}_2$ ) was obtained from FEW Chemicals GmbH (Bitterfeld-Wolfen, Germany), while ethyl acetate (EtAc, 99.9%) was purchased from VWR International (Gdańsk, Poland).

### 2.2. Wine samples and preparation procedure

The 16 polish wines samples used in this work were commercially available. Wine characteristics, such as grape variety or alcohol content, are listed in Table 1. All samples were stored at room temperature and were protected from light. Directly before the analysis wine samples were filtered through a 0.45  $\mu\text{m}$  PES syringe filter.

Sample preparation for smartphone-based analysis was performed following the procedure described by Kalinowska *et al.*<sup>15</sup> 1.6 mL of ethanol, 100  $\mu\text{L}$  of S0378 dye solution ( $0.5 \text{ g L}^{-1}$ ), 10  $\mu\text{L}$  of TEA and 100  $\mu\text{L}$  of wine were mixed in a glass vial, which was then filled up to 2 mL with ultrapure water. The solution was then vortexed for 30 s at 2500 rpm using Vortex MX-S (Chemland, Stargard, Poland). After that, the sample was placed in a water bath ( $70 \text{ }^\circ\text{C}$ ) for 2 hours.

### 2.3. Smartphone-based analysis

The experimental setup for the smartphone-based analysis is shown in Fig. 1. It is designed as a low-cost, customizable and modular solution that facilitates taking reproducible images of the illuminated sample while eliminating interfering variables such as exposure to ambient light or differences in the focal distance. It was 3D printed in four elements with the Prusa i3 MK2s FFF (Fused Filament Fabrication) 3D printer (Prusa Research a.s., Prague, Czech Republic) using black PLA (polylactic acid-based) filament – a ubiquitous, bio-based, and safe material.<sup>16</sup> The first element of the setup is a smartphone mount adjusted to accommodate a particular phone model. The main factor here is the position of the smartphone camera relative to the body, since modern smartphones are designed with the main camera in both in-axis and off-axis configurations. The solution was successfully tested during the development of the Xiaomi Mi 9T, Xiaomi Mi 10T, Samsung Galaxy S8, and Huawei Mate 20 lite. The sample is placed in a standard, 10 mm optical glass or polymer spectrometer cell cuvette, housed in-axis with the camera, and covered with a snap-on cap to shield from ambient light. The optical path is raised above the ground plane (the base of the setup) to accommodate smartphones with larger distances between the main camera and the top edge of the case. The cell compartment is connected with the smartphone mount with a tubular interface that is slightly longer than the minimum focusing distance of the camera and slots into both elements with a protruding bottom lip for structural rigidity. The sample is back-illuminated with

Table 1 Wine samples characteristics

Label	Harvest year	Wine type	Alcohol content [%]	Grape type	Sugar content
1R	2015	Red	11.0	Regent	Dry
4R	2013	Red	12.5	Regent	Dry
6R	2017	Red	11.0	Rondo	Dry
9R	2015	Red	11.5	Rondo	Dry
1W	2016	White	12.0	Johanniter	Dry
2W	2017	White	12.0	Riesling	Semi-dry
3W	2016	White	12.0	Pinot Gris, Riesling, Muscat Ottonel, Gewurztraminer	Semi-dry
4W	2017	White	12.0	Seyval blanc, Hibernat, Johanniter, Solaris	Semi-dry
7W	2014	White	12.0	Bianca	Dry
8W	2017	White	12.5	Solaris	Dry
9W	2017	White	12.0	Mix of grapes	Semi-sweet
10W	2015	White	11.5	Mix of 8 grapes	Dry
1Ro	2014	Rosé	10.5	Zweiglet	Semi-dry
2Ro	2015	Rosé	10.5	Regent	Dry



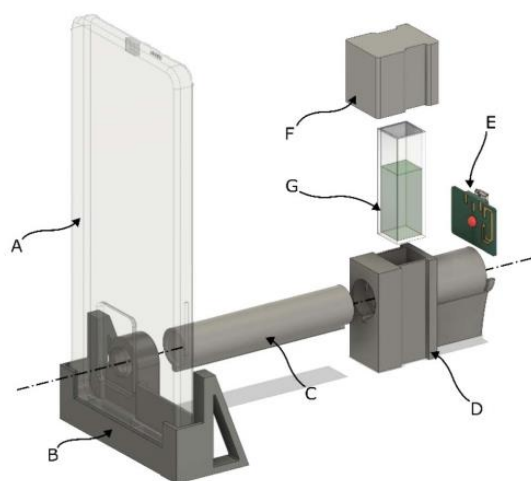

**Fig. 1** Exploded sketch of the 3D-printed smartphone-based setup comprised of: a smartphone equipped with a digital camera (A), a smartphone stand/mount (B), a distance piece matching the approximate minimum focal distance of the smartphone's main camera (C), cell compartment raised from the base to accommodate different smartphone camera positions relative to the case edge (D), a custom PCB fitted with a 880 nm IR & 660 nm LED, a resistor, and a micro-USB connector (E) (mounted with the LED in axis with the smartphone's camera, shown here above the mounting slot for clarity), a cover (F), and a standard 10 mm spectrometer cell cuvette containing the sample (G).

a  $3.5 \times 2.8 \times 1.9$  mm 880 nm IR & 660 nm red SMD LED (OSIRCAS2C1A-880 nm, Optosupply Ltd, Honk Kong) with a unit cost of <1 USD. During development the LED was powered using a laboratory power supply and afterwards it was mounted on a home-made PCB fitted with a micro-USB connector and a 5 W 7.5  $\Omega$  resistor that slots in-axis with the smartphone camera. The 3D models of the setup are available for download, adjustment, and 3D printing at <https://thingiverse.com/thing:5683104>.

Xiaomi Mi 10T 5G smartphone was used as the image-capturing device. This model has a 6.67-inch touchscreen display with a resolution of 1080 by 2400 pixels and a 64-megapixel camera with a fixed  $f/1.89$  aperture lens and the Sony IMX682 backside illumination sensor. The images were obtained using the smartphone's built-in camera at the highest possible resolution and saved as JPGs. In order to avoid fluctuations due to lighting change or smartphone behaviour, all of the samples were measured with the same parameters applied: exposure ( $S$ ) set to  $1/4000$  s, ISO of 100, focal length of 5.43 mm and white balance set to 5600 K.

ImageJ (Rasband, W. S., ImageJ, U. S. National Institutes of Health, Bethesda, Maryland, USA, <http://imagej.nih.gov/ij/>) was used for image analysis (area selections and colour measurements).  $R_{\text{mean}}$  channel values of the selected area ( $50 \times 50$  pixels) were measured. The obtained  $R_{\text{mean}}$  values were subtracted from 255. Least squares linear regression was used

to calculate the equation of the calibration curve and the determination coefficient ( $R^2$ ).

#### 2.4. Quality assurance (QA)

Linearity, precision, sensitivity, and accuracy of the developed smartphone-based method were evaluated in accordance with the quality assurance protocol. Linearity was examined based on 12 different concentrations. Limits of detection (LOD) and quantification (LOQ) were assessed based on the linear calibration equation and 10 blank samples. Calculations were made using the following equations:  $\text{LOD} = 3 \times \text{SD}/m$  and  $\text{LOQ} = 10 \times \text{SD}/m$ , where SD is the standard deviation of the measurements of 10 blank samples and  $m$  is the slope of the calibration curve.<sup>17</sup> The intra-day ( $\text{RSD}_t$ ) and inter-day ( $\text{RSD}_R$ ) precision were determined by the application of seven replicates of wine samples spiked with putrescine at two levels (30 and 50  $\text{mg L}^{-1}$ ). Recovery was estimated using the calculated concentration of the samples of wine spiked with the known concentration (60  $\text{mg L}^{-1}$ ) of biogenic amines relative to the concentration of the spike itself ( $n = 5$ ).

#### 2.5. Sample preparation for GC-MS analysis

The preparation of wine samples for analysis with the use of GC-MS was described in detail by Fabjanowicz *et al.*<sup>18</sup> 5  $\mu\text{L}$  of filtered wine was enriched with 1.5  $\mu\text{L}$  of IS at a concentration of 50  $\text{mg mL}^{-1}$  and mixed with 11.0 mg of sodium chloride. 11  $\mu\text{L}$  of NaOH solution (1.0  $\text{mol L}^{-1}$ ) was added to the sample to facilitate the carbamate formation, followed by the addition of 1.2  $\mu\text{L}$  of the derivatizing reagent (ECF) and 1.2  $\mu\text{L}$  of TEA. The solution was then mixed with 50  $\mu\text{L}$  of EtAc, vortexed for 10 s at 2500 rpm, and centrifuged for 1.5 min at 3500 rpm (FVL-2400 N Combi-Spin, Biosan, Józefów, Poland). Finally, an aliquot of the upper organic phase was collected and analysed using GC-MS.

#### 2.6. GC-MS analysis

Wine samples analysis was carried out following the procedure previously described in detail by Fabjanowicz *et al.* and Różańska *et al.*<sup>18,19</sup> In short, the chromatographic separation and identification of the analytes were performed using a GC-MS instrument (Agilent Technologies, Santa Clara, CA, USA) consisting of an Agilent 7890A gas chromatograph coupled to an Agilent 5975C single quadrupole mass spectrometer. 2  $\mu\text{L}$  of the extract was transferred into an injector which was operated at 240  $^\circ\text{C}$  in splitless mode. Helium (99.999% pure, Air Liquide, Kraków, Poland) was used as a carrier gas (flow rate of 1.0  $\text{mL min}^{-1}$ ). The temperature program started at 55  $^\circ\text{C}$ , was held for 4 min, then increased to 280  $^\circ\text{C}$  at 50  $^\circ\text{C min}^{-1}$ , and maintained for 7.5 min. All targeted derivatives were separated within 16 min. A fused silica capillary column (0.3  $\text{m} \times 0.25$  mm, Phenomenex, Torrance, CA, USA) connected to a ZB-5MS capillary column (30  $\text{m} \times 0.25$  mm  $\times$  0.25  $\mu\text{m}$ , Zebron, Phenomenex, Torrance, CA) were used. The MS transfer line temperature was held at 300  $^\circ\text{C}$ . Mass spectrometric parameters were set as follows: electron impact ionization with 70 eV energy, ion source temperature at 250  $^\circ\text{C}$ , detector temperature at 150  $^\circ\text{C}$ , the scan  $m/z$  range was set to 30–500 amu.

## Analytical Methods

Synchronous scan/selected ion monitoring (SIM) mode was used for the collection of both types of data in each run with solvent delay set at 4.5 min. In SIM mode each analyte was quantified based on peak area using one quantification ion and two qualifier ions. Data were acquired using MSD ChemStation, Ver. E.02.00.493 software from Agilent Technologies. Chromatographic data were processed using MZmine 2.<sup>20</sup>

### 3. Results and discussion

The factors affecting the determination of biogenic amines using a smartphone are parameters of the light source (type, voltage, current) and the procedure of image analysis (size of the analysed area, channel). During preliminary studies standard solution was photographed, when different voltages and currents were set using a laboratory power supply. The LED performed best at 2.2 V and 0.2 mA. Then, various sizes of the analysed area were tested. As shown in Fig. 2, the most linear response was observed for the area of 2500 pixels ( $50 \times 50$  pixels) and thus, it was used for validation and real samples analysis.

As pointed out by A. Scheeline,<sup>21</sup> phones are typically programmed to respond nonlinearly when converting the image in order to produce vivid, aesthetically pleasing outputs. Thus, we cannot count on a straightforward and linear relationship between the response of the green and red pixels of the smartphone's CMOS sensor and the G and R channels of the processed JPG image. Because of that, red (R), green (G), and blue (B) channel values of the selected area ( $50 \times 50$  pixels) were measured. For each channel mean, minimum and maximum values were obtained. Least squares linear regression was used to calculate the equations of the calibration curves and the determination coefficients ( $R^2$ ) for each set of values. It was found that the best parameters for BAs analysis are obtained with the use of mean values of red channel ( $R_{\text{mean}}$ , Fig. 3), which was to be expected since part of the light emitted from the diode is in the red range of the visible light spectrum.

#### 3.1. Method validation

The method's linearity and sensitivity were assessed by calibration with standard solutions of putrescine. Different

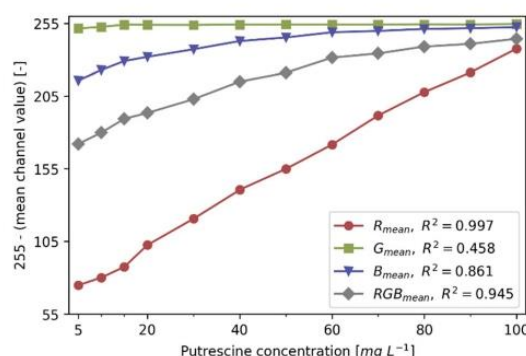

Fig. 3 Calibration curves for red, blue and green channels.

amounts of putrescine standard were added to wine in order to obtain 12 solutions with concentrations ranging from  $1 \text{ mg L}^{-1}$  to  $100 \text{ mg L}^{-1}$ , which were then subjected to the developed procedure. Least squares linear regression was used to calculate the equations of the calibration curves and the determination coefficients ( $R^2$ ). The linearity was excellent with a determination coefficient of 0.9981. The LOD and LOQ equated  $0.28 \text{ mg L}^{-1}$  and  $0.94 \text{ mg L}^{-1}$ , respectively.  $\text{RSD}_r$  ranged from  $2.3 \text{ mg L}^{-1}$  to  $3.6 \text{ mg L}^{-1}$ , while  $\text{RSD}_R$  ranged from 2.4% to 3.9% (Table 2). The accuracy of the method was determined by a recovery test. Results of the analysis of wine samples spiked with putrescine standard ( $50 \text{ mg L}^{-1}$ ,  $n = 7$ ) were compared with the concentration of spikes themselves, and the recovery was  $96.2\% \pm 3.6\%$ .

#### 3.2. Greenness evaluation

The developed analytical procedure for the determination of  $\text{PUT}_{\text{eq}}$  in wine samples was subsequently assessed in terms of its greenness using the Analytical Greenness Calculator (AGREE).<sup>14</sup> In this approach, greenness assessment is made based on a set of criteria that correspond to the 12 principles of green analytical chemistry (SIGNIFICANCE),<sup>22</sup> e.g. sustainability of the reagents, throughput, energy consumption, etc. The scores corresponding to these 12 criteria are expressed as values on 0–1 scale, with 1 corresponding to the best performance. The

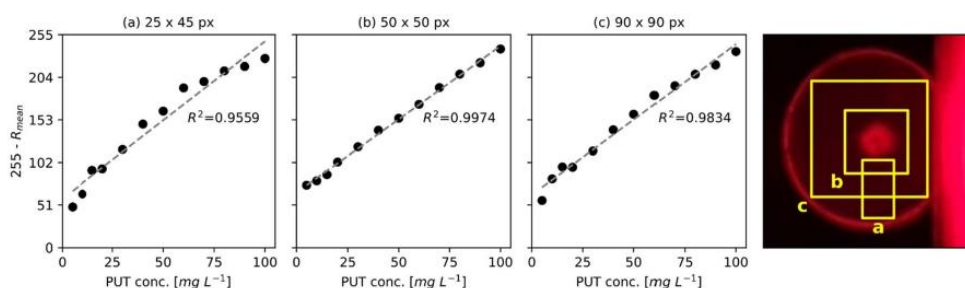

Fig. 2 Impact of the size of a selected area on resulting red channel mean values and their dependence on the concentration of the standard solutions.

Table 2 Analytical figures of merit for developed methodology

Concentration range [mg L <sup>-1</sup> ]	Linearity (R <sup>2</sup> )	Intra-day repeatability, n = 7 (% RSD)		Recovery (%)	Inter-day repeatability, n = 7 (% RSD)		LOD [mg L <sup>-1</sup> ]	LOQ [mg L <sup>-1</sup> ]
1–100	0.9981	30 mg L <sup>-1</sup> 2.3	60 mg L <sup>-1</sup> 3.6	96.2 ± 3.6	30 mg L <sup>-1</sup> 2.4	60 mg L <sup>-1</sup> 3.9	0.28	0.94

overall score is a weighted average of the individual scores. The result is a colour-coded pictogram indicating the final score and performance of the analytical procedure in each criterion. To evaluate its environmental impact, the developed procedure was juxtaposed with three other methods for BAs determination: DI-SPME-GC-MS in which derivatization is performed with the use of isobutyl chloroformate and extraction through direct immersion (DI) procedure,<sup>23</sup> SALLE-HPLC-FLD, where analysis is preceded by salting-out assisted liquid-liquid extraction (SALLE) and derivatization with dansyl chloride<sup>24</sup> and UPLC-UV-vis preceded by dansyl chloride derivatization.<sup>25</sup> In addition, assessment of the greenness was made for reference GC-MS-based method, which obtained the score of 0.55. The main disadvantage of the developed method, from both greenness and metrological points of view, is the fact that only PUT<sub>eq</sub> content is determined *in lieu* of the content of multiple BAs (from 8<sup>23,24</sup> to 14 amines<sup>25</sup>). However, a decrease in the number of analytes results in simplification of the procedure and thus, the method is more equitable. What is more, the use of a smartphone facilitates detection, which results in a reduction of analysis time to a couple of seconds, which is significantly lower than in the case of chromatography-based methods (from 18 to 40 min). LOD and LOQ obtained for the developed smartphone-based method are higher than for the other methods: for the proposed method LOD equalled 0.28 mg L<sup>-1</sup>, while in other procedures it ranges from 0.009 µg L<sup>-1</sup><sup>25</sup> to 0.18 mg L<sup>-1</sup>.<sup>23,24</sup> However, since the proposed solution aims at the determination of total biogenic amines content, the limit of detection can be higher than in the case of particular amines determination. Furthermore, the use of a smartphone instead of GC, HPLC, or UPLC increases the equitability of the method as it can be applied in routine analyses performed outside of the laboratory, even by unskilled analysts.

Based on the obtained results for the greenness assessment (Fig. 4), a smartphone-based procedure developed in this work is the greenest. Compared to other methods, its main advantage is the lack of extraction, which reduces the amount of reagents used and limits their possible negative impact on the analyst's health or on the environment. To further reduce the negative impact on the environment, the throughput of the methodology was increased by simplification of the detection step. What is more, the use of the proposed method results in a significant decrease in energy consumption as compared to other methods for BAs determination.

### 3.3. Real samples analysis

The developed smartphone-based analytical method was used for putrescine equivalent determination in 14 Polish wines.

Eight white, four red and two rosé wines were analysed in five replicates using the proposed approach. The level of the total biogenic amines content was in the range of approx. 1.0–4.3 mg L<sup>-1</sup>, which is within the ranges reported in the literature.<sup>26</sup>

In order to evaluate whether the proposed smartphone-based method for putrescine equivalent determination could provide useful information on total biogenic amines content, method equivalence was assessed.<sup>27</sup> A set of measurements was made using the GC-MS-based method and compared with results obtained with the use of the smartphone-based method. In order to obtain total biogenic amines content from levels of 14 particular amines, putrescine equivalent was calculated. Since the S0378 dye reacts with primary amines according to the S<sub>N</sub>1 mechanism with colour change being a result of conjugate formation, monoamines bind to a single S0378 dye molecule and polyamines, e.g. cadaverine, react to two or more dye molecules depending on the number of -NH<sub>2</sub> groups.<sup>15,28</sup> Because of that, the number of amino groups in a molecule was considered when calculating the putrescine equivalent. The results were then compared with results obtained with the use of a smartphone-based procedure. F test and Student's *t*-test were used to assess whether the results are equivalent. Based on both statistical tests, the results obtained with both methods do not differ from each other in a statistically significant manner.

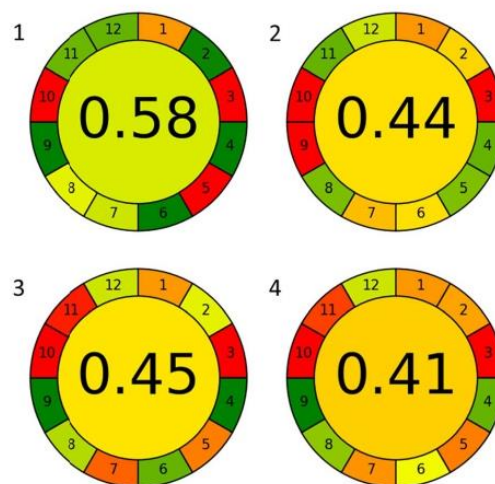

Fig. 4 Results of greenness evaluation of 4 analytical methodologies for BAs determination in wines: (1) proposed procedure, (2) DI-SPME-GC-MS,<sup>23</sup> (3) SALLE-HPLC-FLD,<sup>24</sup> (4) UPLC-UV-vis.<sup>25</sup> The higher the score, the greener the method is.

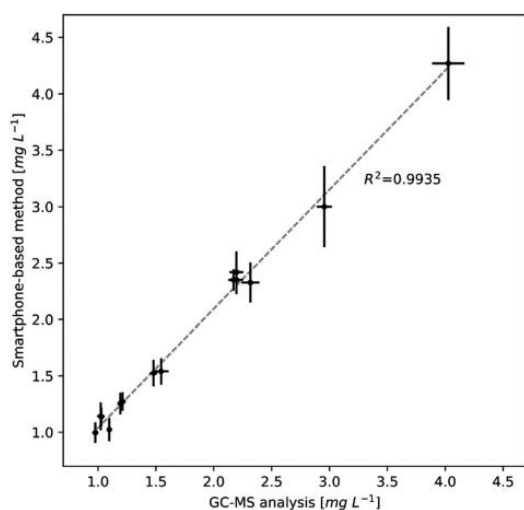

Fig. 5 Result of determination of the total biogenic amines content. Horizontal and vertical error bars denote SD ( $n = 5$ ) for the GC-MS and smartphone-based methods, respectively.

What is more, based on the results obtained with the use of GC-MS putrescine was one of the most abundant BAs in all studied wines, which further proves putrescine equivalent applicability.

The total BAs content in wine samples is shown in Fig. 5. Based on these results, it can be observed that the samples of white wines were characterized by a relatively high variation in BAs concentrations, while in the case of red and rosé wines differences were less pronounced. This may be caused by the fact that the amount of BAs depends on multiple factors, such as the storage conditions, the production technology, microbial activity, or the initial content of amines in grapes.<sup>14</sup> However, the total biogenic amines content was relatively low ( $<4.5 \text{ mg L}^{-1}$ ) in all samples.

### 3.4. Discussion

Since the aim of developing portable and user-friendly methodologies that can be easily used outside of the laboratory is to increase the availability of food quality evaluation, a balance has to be struck between sensitivity and accessibility of the method. While the proposed method of biogenic amines determination has a higher limit of detection than some biosensor-based methods,<sup>29–31</sup> it can be successfully used by both specialized personnel and non-trained consumers. It is also worth noting that while the application of *e.g.* nanomaterials allows for quick measurement with satisfactory sensitivity, the analysis has to be preceded by synthesis of nanomaterial, which significantly increases the cost of analysis and complicates it further.<sup>30</sup> In addition, methods based on observing pH changes to infer biogenic amines content are fairly uncomplicated to perform, however, it is at the cost of selectivity, since biogenic amines are not the only compounds that can affect the pH of food.<sup>31</sup>

The developed procedure for determination of the total biogenic amines content in wine is simple to perform and green. The use of photometry drastically increases the accessibility of the proposed procedure which would otherwise require trained personnel, costly equipment, and infrastructure, thus promoting equitable analytical chemistry. Simplification of the sample preparation and determination stages translates, through the reduction of the number of analytical steps in a procedure, to reduced consumption of reagents and increased user-friendliness, resulting in a more sustainable alternative for the determination of the total BAs content.

## 4. Conclusions

A novel smartphone-based analytical method for total biogenic amines content determination was developed and fully validated. The proposed method is inexpensive, fast, and environmentally friendly, which was assessed using the Analytical Greenness Calculator. The method displays satisfactory linearity ( $R^2 = 0.9981$ ), excellent accuracy ( $96.2 \pm 3.6\%$ ), good repeatability (2.3–3.6%) and reproducibility (2.4–3.9%). The obtained results confirmed that the smartphone-based method was suitable for the determination of BAs at trace levels (sub- $\text{mg L}^{-1}$ ) in liquid food samples. The developed method can be a useful tool for monitoring food quality and ensuring food safety in terms of biogenic amines content.

## Author contributions

Kaja Kalinowska: conceptualization, methodology, investigation, validation, writing – original draft. Wojciech Wojnowski: writing – review & editing, visualization, methodology. Marek Tobiszewski: writing – review & editing, supervision.

## Conflicts of interest

There are no conflicts to declare.

## Acknowledgements

The authors would like to thank Bartosz Szulczyński for his help with selecting, optimizing and mounting the LED light source, Anna Różańska for her support during optimization of the sample preparation procedure, Magdalena Fabjanowicz and Justyna Płotka-Wasyłka for support during GC-MS analysis.

## Notes and references

- 1 J. Karovicova and Z. Kohajdova, *Chem. Pap.*, 2005, **59**(1), 70.
- 2 A. Önal, *Food Chem.*, 2007, **103**(4), 1475.
- 3 M. Triki, A. Herrero, F. Jiménez-Colmenero and C. Ruiz-Capillas, *Foods*, 2018, **7**(9), 132.
- 4 D. Doeun, M. Davaatseren and M.-S. Chung, *Food Sci. Biotechnol.*, 2017, **26**(6), 1463.
- 5 C. Ancín-Azpilicueta, N. Jiménez-Moreno and C. Sola-Larrañaga, in *Innovations in Traditional Foods*, ed. C. Galanakis, Elsevier, 2019, vol. 9, p. 221.

- 6 K. Kalinowska, W. Wojnowski and M. Tobiszewski, *Trends Food Sci. Technol.*, 2021, **111**, 271.
- 7 F. Chemat, S. Garrigues and M. de la Guardia, *Curr. Opin. Green Sustainable Chem.*, 2019, **19**, 94.
- 8 R. Marcinkowska, J. Namieśnik and M. Tobiszewski, *Curr. Opin. Green Sustainable Chem.*, 2019, **19**, 19.
- 9 A. S. Tsagkaris, J. L. D. Nelis, K. Campbell, C. T. Elliott, J. Pulkabova and J. Hajslova, in *Microfluidic Biosensors*, eds W. C. Mak and A. H. Pui Ho, Academic Press, 2023, vol. 8, p. 233.
- 10 J. L. D. Nelis, A. S. Tsagkaris, M. J. Dillon, J. Hajslova and C. T. Elliott, *Trends Anal. Chem.*, 2020, **129**, 115934.
- 11 M. Badea, F. di Modugno, L. Floroian, D. M. Tit, P. Restani, S. Bungau, C. Iovan, G. E. Badea and L. Aleya, *Sci. Total Environ.*, 2019, **672**, 129.
- 12 S. Sheoran, P. Nidhi, V. Kumar, G. Singh, U. R. Lal, A. Sourirajan and K. Dev, *Vegetos*, 2019, **32**(3), 387.
- 13 Q. Shi, Z. Zhang, J. Su, J. Zhou and X. Li, *Molecules*, 2018, **23**(8), 1917.
- 14 F. Pena-Pereira, W. Wojnowski and M. Tobiszewski, *Anal. Chem.*, 2020, **92**(14), 10076.
- 15 K. Kalinowska and M. Tobiszewski, *Food Chem.*, 2023, **402**, 134457.
- 16 W. Wojnowski, K. Kalinowska, T. Majchrzak and B. Zabiegała, *Sci. Total Environ.*, 2022, **805**, 150181.
- 17 A. P. Mörschbacher, A. Dullius, C. H. Dullius, C. R. Bandt, D. Kuhn, D. T. Brietzke, F. J. Malmann Kuffel, H. P. Etgeton, T. Altmayer, T. E. Gonçalves, E. Q. Oreste, A. S. Ribeiro, C. F. V. de Souza and L. Hoehne, *Food Chem.*, 2018, **255**, 182.
- 18 M. Fabjanowicz, A. Róžańska, K. Kalinowska and J. Plotka-Wasyłka, *Microchem. J.*, 2022, **180**, 107616.
- 19 A. Róžańska, M. Fabjanowicz, K. Kalinowska, Ż. Polkowska and J. Plotka-Wasyłka, *Food Chem.*, 2022, **384**, 132557.
- 20 T. Pluskal, S. Castillo, A. Villar-Briones and M. Orešič, *Bioinformatics*, 2010, **11**(1), 395.
- 21 A. Scheeline, *Trends Anal. Chem.*, 2022, **149**, 116564.
- 22 A. Gałuszka, Z. Migaszewski and J. Namieśnik, *Trends Anal. Chem.*, 2013, **50**, 78.
- 23 M. Papageorgiou, D. Lambropoulou, C. Morrison, J. Namieśnik and J. Plotka-Wasyłka, *Talanta*, 2018, **183**, 276.
- 24 R. M. Ramos, I. M. Valente and J. A. Rodrigues, *Talanta*, 2014, **124**, 146.
- 25 M. F. Angulo, M. Flores, M. Aranda and K. Henriquez-Aedo, *Food Chem.*, 2020, **309**, 125689.
- 26 M. Papageorgiou, D. Lambropoulou, C. Morrison, E. Kłodzińska, J. Namieśnik and J. Plotka-Wasyłka, *Trends Anal. Chem.*, 2018, **98**, 128.
- 27 P. Konieczka, J. Namieśnik and, *Quality Assurance and Quality Control in the Analytical Chemical Laboratory: A Practical Approach*; CRC Press, Cornwall, 2016.
- 28 H. H. Gorris, S. M. Saleh, D. B. Groegel, S. Ernst, K. Reiner, H. Mustroph and O. S. Wolfbeis, *Bioconjugate Chem.*, 2011, **22**(7), 1433.
- 29 H. Ahangari, S. Kurbanoglu, A. Ehsani and B. Uslu, *Trends Anal. Chem.*, 2021, **112**, 75.
- 30 J. Navarro, S. de Marcos and J. Galbán, *Microchim. Acta*, 2020, **187**, 174.
- 31 Y. Qin, W. Ke, A. Faheem, Y. Ye and Y. Hu, *Food Chem.*, 2023, **404**, 134581.

## **5.5. Simple smartphone-based methods for the determination of bioactive compounds in wine**

Kalinowska, K., Hussain M. S., Tobiszewski, M., Simple smartphone-based methods for the determination of bioactive compounds in wine (unpublished)

# Simple smartphone-based methods for the determination of bioactive compounds in wine

Kaja KALINOWSKA, Muhammad Saad HUSSAIN, Marek TOBISZEWSKI

## Abstract

A set of simple smartphone-based methods of bioactive compounds determination were developed for wine analysis. Procedures for smartphone-based determination of the total content of phenolic compounds, flavonols, anthocyanins and biogenic amines, as well as measurement of antioxidant activity, using DPPH and ABTS, were developed and fully validated. The proposed solutions had satisfactory figures of merit with  $R^2$  in the range of 0.9860 - 0.9981 for linear range. In order to demonstrate the applicability of the proposed procedures, wine samples were analysed using spectrophotometry and developed methods.

## Keywords:

wine, smartphone, food, spectrophotometry, bioactive compounds, total phenolic content, antioxidant activity

## Highlights

- Novel smartphone-based methods for wine analysis were developed.
- Developed methods were applied for the determination of bioactive compounds in wines.
- Smartphone-based detection facilitates in-field analysis.
- Proposed solution can be used in routine food quality assessment.
- The obtained results were comparable to those obtained with UV/Vis spectrophotometry.

This study was aimed at developing novel smartphone-based techniques, which could be used instead of commonly applied spectrophotometric methods. Methods for smartphone-based measurement of the content of phenolic, anthocyanins, and other bioactive compounds routinely used in wine quality assessment were developed and validated. In order to demonstrate the applicability of the proposed procedures, 49 commercially available wines were analysed with the use of both a smartphone and a spectrophotometer and the results were juxtaposed. Additionally, it was investigated whether the correlation between the results of particular analytes' determinations can be observed.

## 1. Introduction

Quality and safety of food are steadily gaining interest both due to their effect on the well-being of society and consumers' awareness of the importance of food quality. As a result, there is a growing need for novel analytical methods, which could be used for food quality assessment and monitoring at each stage of production and distribution (Kalinowska *et al.*, 2021). In the case of large-scale farming, quality assurance could be performed with the use of sophisticated equipment and time-consuming procedures. However, these methods cannot be applied outside of the large processing plants and thus, cannot be applied as a means of food quality monitoring (Kalinowska *et al.*, 2021). As a result, emphasis should be put on the development of methods that could be applied by non-trained users with the use of low-cost and readily available equipment.

## 2. Materials and methods

### 2.1. Reagents

(±)-6-Hydroxy-2,5,7,8-tetramethylchromane-2-carboxylic acid (trolox, 97%), putrescine (PUT, 97.5%), 3,3',4,5,7-Pentahydroxyflavone (quercetin, 98%), gallic acid ((HO)<sub>3</sub>C<sub>6</sub>H<sub>2</sub>COOH, 100%) were purchased from Merck Life Science Sp. z o.o. (Merck, Poznań, Poland). Cyanidin 3-*O*-glucoside chloride (C<sub>21</sub>H<sub>21</sub>ClO<sub>11</sub>, 98%) was obtained from Chemat Adam Taszner (Gdańsk, Poland). Stock solutions (1000 mg/L) of quercetin and trolox were prepared in ethanol (EtOH, 99.8%), while other stock solutions were prepared in ultrapure water (HLP5 Hydrolab demineralizer, Wiślnia, Poland). Standard solutions were freshly prepared by diluting stock solution.

Methanol (MeOH, 99.9%), 2,2-Diphenyl-1-picrylhydrazyl radical (DPPH•, 100%), 2,2-Azino-bis(3-ethylbenzothiazoline-6-sulfonic acid) diammo-

nium salt (ABTS, 98%), ammonium persulfate ((NH<sub>4</sub>)<sub>2</sub>S<sub>2</sub>O<sub>8</sub>, 98%), triethylamine (TEA, 99.5%), aluminium chloride (AlCl<sub>3</sub>, 100%), sodium acetate (CH<sub>3</sub>COONa, 99%) were obtained from Merck Life Science Sp. z o.o. Ethanol (EtOH, 99.8%), potassium chloride (KCl, 99.5%), potassium acetate (CH<sub>3</sub>COOK, 99%), and hydrochloric acid (HCl, 35 - 38%) were purchased in Avantor Performance Materials (formerly POCH, Gliwice, Poland). The long-wavelength absorbing cyanine dye S 0378 (C<sub>37</sub>H<sub>44</sub>ClN<sub>2</sub>NaO<sub>6</sub>S<sub>2</sub>) was obtained from FEW Chemicals GmbH (Bitterfeld-Wolfen, Germany). Sodium carbonate (Na<sub>2</sub>CO<sub>3</sub>, 99.8%) and Folin-Ciocalteu's phenol reagent were obtained from Chempur (Piekary Śląskie, Poland).

## 2.2. Wine samples

49 commercially available wines were analysed in this work. Wine characteristics, such as grape variety or alcohol content, are depicted in Supplementary Materials (Table S1). All samples were stored at room temperature and were protected from light. Spectroscopic and smartphone-based analysis was performed directly after the bottles' opening.

## 2.3. Spectroscopic measurements

### 2.3.1. Total phenolic content determination (TPC)

Total phenolic content was measured using Folin-Ciocalteu's assay described by Miceli *et al.* (Miceli *et al.*, 2017) with slight modifications. 1 ml of distilled water was mixed with 100 μL of Folin Ciocalteu's reagent and 50 μL of appropriately diluted sample. 500 μL of 15% Na<sub>2</sub>CO<sub>3</sub> was added to the solution, which was then vortexed for 10 s at 2500 rpm and incubated for 2 h at room temperature. Finally, the sample was analysed using a spectrophotometer (Hach-Lange DR 3900, Colorado, United States) with absorbance measured at 765 nm. Total phenolic content was calculated as gallic acid equivalent (GAEq).

### 2.3.2. Total flavonol content (TFC)

Total flavonoid content was measured using the aluminium chloride colourimetric method (Chang *et al.*, 2002). 125 μL of the sample was mixed with 375 μL of methanol, 50 μL of 10% aluminium chloride solution in ethanol, 25 μL of 1M potassium acetate solution in methanol, and 1.4 ml of distilled water. After 30 min incubation sample was spectrophotometrically measured at 415 nm. Total flavonol content was estimated as quercetin equivalent (QE) and expressed as mg QE \* L<sup>-1</sup>.

### 2.3.3. DPPH radical scavenging activity (DPPH assay)

The free radical scavenging activity of the sample has been evaluated using the DPPH (2,2-diphenyl-1-picrylhydrazyl) test (Habibatni *et al.*, 2016). 125 μL

of the sample, appropriately diluted in methanol, was mixed with 750 μL of 0.1 mM DPPH solution (prepared daily in methanol). Solution was then incubated for 20 min at room temperature and analysed at 517 nm. The scavenging activity was measured as the absorbance of the solution with results estimated as trolox equivalent (TEq).

### 2.3.4. Antioxidant capacity assay (ABTS assay)

Antioxidant activity was assessed using a 2,2'-azino-bis(3-ethylbenzothiazoline-6-sulfonic acid) (ABTS) assay (Tchabo *et al.*, 2017). 7 mM aqueous solution of ABTS was mixed with 140 mM aqueous solution of (NH<sub>4</sub>)<sub>2</sub>S<sub>2</sub>O<sub>8</sub> in the proportion of 1:18 (v/v) and then incubated in the darkness for 16 h in order to obtain ABTS radical cation solution. Before the analysis solution was diluted with ethanol in order to obtain an absorbance of 0.70 ± 0.02 at 734 nm. Afterwards, 50 μL of the sample was added to 2450 μL of the solution, vortexed for 10 s at 2500 rpm and incubated in the dark for 15 min. Then absorbance of the solution was measured at 734 nm with results estimated as trolox equivalent (TEq).

### 2.3.5. Total anthocyanin content (TAC)

Total anthocyanin content was measured with the use of the pH differential method (Lee *et al.*, 2005). 100 μL of the sample was mixed with 900 μL of buffer with a pH of 1.0 (0.025 M KCl), and another 100 μL was mixed with 900 μL of buffer with a pH of 4.5 (0.4 M CH<sub>3</sub>COONa). After 20 - 50 min absorbance of sample diluted with both buffers was measured at 520 and 700 nm, with measurements at 700 nm performed in order to correct for haze. Anthocyanin pigment concentration, expressed as cyanidin-3-glucoside equivalent (Total monomeric anthocyanins, TMO), was calculated as follows :

$$TMO [mg * L^{-1}] = \frac{A * MW * D * 100}{e} \quad (1)$$

where A = (A<sub>520nm</sub> - A<sub>700nm</sub>)<sub>(pH=1.0)</sub> - (A<sub>520nm</sub> - A<sub>700nm</sub>)<sub>(pH=4.5)</sub>; MW (molecular weight) = 449.2 g\*mol<sup>-1</sup> of cyanidin-3-glucoside (cyd-3-glu); DF = dilution factor; l = pathlength in cm; molar extinction coefficient e = 26 900 L\*mol<sup>-1</sup>\*cm<sup>-1</sup>, for cyd-3-glu; 10<sup>3</sup> = factor for conversion from g to mg.

### 2.3.6. Total biogenic amines content (TBAC)

Total biogenic amines content was measured using the previously described method (Kalinowska and Tobiszewski, 2023). 100 μL of the sample was mixed with 0.6 mL of ethanol, 100 μL of long-wavelength absorbing cyanine dye S 0378 solution (0.5 g\*L<sup>-1</sup> in ethanol) and 10 μL of trimethylamine. The vial was then filled up to 2 mL with ultrapure water. Afterwards, the solution was vortexed for 30 s at 2500 rpm



and placed in a water bath (70 °C) for 2 h. Finally, absorbance was measured at 650 nm. Total biogenic amines content was then calculated as putrescine equivalent (PUTEq).

### 2.3.7. Colour assessment

The colour of the samples was measured using the method described by Cliff *et al.* (Cliff *et al.*, 2007). Absorbance was measured at 420, 520 and 700 nm and then, colour density and hue were calculated:

$$\text{Colour density} = (A_{520 \text{ nm}} - A_{700 \text{ nm}}) + (A_{420 \text{ nm}} - A_{700 \text{ nm}}) \quad (2)$$

$$\text{Colour hue} \backslash \text{tint} = \frac{A_{420 \text{ nm}} - A_{700 \text{ nm}}}{A_{520 \text{ nm}} - A_{700 \text{ nm}}} \quad (3)$$

## 2.4. Smartphone-based analysis

### 2.4.1. Experimental setup

The experimental setup was designed in order to facilitate taking reproducible images of the sample while eliminating interfering variables such as exposure to ambient light or differences in the focal distance. The proposed customizable, low-cost, and modular solution, depicted in Figure 1, was described previously by Kalinowska *et al.* (Kalinowska *et al.*, 2023). It was 3D printed using the Prusa i3 MK2s FFF (Fused Filament Fabrication) 3D printer (Prusa Research a.s., Prague, Czech Republic) and is available for download, adjustment, and 3D printing at <https://thingiverse.com/thing:5683104>.

Polymer or glass cell cuvette containing sample is placed in a cell compartment and covered by a snap-on cap in order to shield it from ambient light. The sample is back-illuminated with LED individually chosen for each determination so that the wavelength of maximum absorbance is within the range of a particular light source. The cell compartment is connected with a tubular interface so that the distance between the sample and the smartphone is greater than the minimum focusing distance of the camera. A smartphone is placed in the mount adjusted for a particular phone model. Then, in order to decrease the interferences caused by smartphone behaviour or lightning change, photographs are taken with the same parameters applied: exposure (S) set to 1/4000 s, ISO of 100, a focal length of 5.43 mm and white balance set to 5600 K. In this experiment, Xiaomi Mi 10T 5G smartphone was used. It has a 6.67-inch touchscreen display (1080 by 2400 pixels resolution) and a 64-megapixel camera with a fixed f/1.89 aperture lens and the Sony IMX682 back-side illumination sensor. The images were obtained using the smartphone's built-in camera at the highest possible resolution and saved as JPGs.

Light sources for each determination are presented in Table S2. During development, LEDs were powered

using a laboratory power supply. Subsequently, they were mounted on homemade PCBs fitted with a micro-USB connector and a 5 W, 7.5 Ω.

### 2.4.2. Image analysis

Image analysis was performed using ImageJ (Rasband, W.S., ImageJ, U. S. National Institutes of Health, Bethesda, Maryland, USA, <http://imagej.nih.gov/ij/>). For each method, a set of solutions with different standard concentrations were subjected to the sample preparation procedure and then photographed. Mean, minimum and maximum of red (R), green (G), and blue (B) channel values of the image's selected area (50 x 50 pixels) were measured. Then, least squares linear regression was used to calculate the equations of the calibration curves and the determination coefficients ( $R^2$ ) for each set of values. Based on the obtained results, a suitable channel or sum of channels was selected for each measurement.

The image analysis method was tested also using the free-to-download ColorPicker Android application (available at [git.pg.edu.pl/p1198182/ColorPicker](http://git.pg.edu.pl/p1198182/ColorPicker)), which was developed in order to facilitate RGB values acquisition using a smartphone. With it, it is possible to obtain minimum, maximum and mean values for each channel, create equations describing the dependence of each channel on a known concentration value, and calculated the concentration of analytes on the basis of calibration curves. Selected images were analysed using the ColorPicker app, results did not differ from those previously obtained, which suggests that the application can be a suitable alternative for ImageJ.

## 2.5. Quality assurance (QA)

Linearity, limits of detection (LOD) and limits of quantification (LOQ) were assessed based on the calibration curves. The intra-day ( $RSD_f$ ) and inter-day ( $RSD_R$ ) repeatability were estimated using wine samples spiked at two levels, accuracy of the method was determined by recovery test (validation procedures described in Supplementary Material).

The linearity of both spectrophotometric and smartphone-based methods' was excellent with determination coefficients in the range of 0.9864 - 0.9979 and 0.9860 - 0.9981, respectively (Table S3). The LODs ranged from 0.28 to 2.37 mg/L and the LOQs ranged from 0.94 to 7.91 mg/L, with the highest values obtained for spectrophotometric flavonols determination and the lowest for antioxidant activity measurements. Averaged recoveries obtained for smartphone-based methods (96 to 102%) were slightly lower than those calculated for spectrophotometric determinations (from 99 to 103%), but all of them were characterized by high accuracy. The stability of all analytes in the wine matrix led to satisfactory precision.

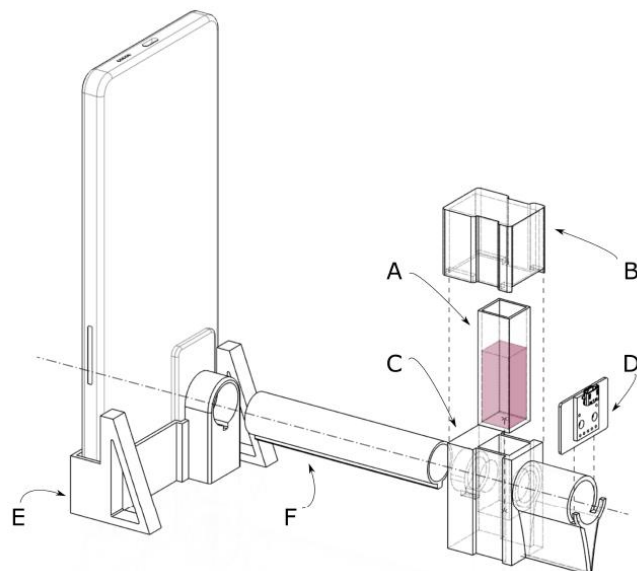

Figure 1: Exploded sketch of the 3D-printed smartphone-based setup. 10mm cell cuvette containing sample (A) is covered by a snap-on cap (B) placed in a cell compartment (C), and back-illuminated with LED fitted on homemade PCB (D). Cell compartment is connected to smartphone mount (E) with a tubular interface (F).

### 3. Results and discussion

Both smartphone-based and spectrophotometer-based methods were used in order to analyse commercially available wines (Table 1). Results obtained using both means of detection are similar (Figure 2), the use of smartphone-based methods resulted in slightly higher standard deviations.

As can be seen in Figure S1, red wines were characterised by different levels of bioactive compounds than other wines. TPC, TFC, ABTS assay and TAC of red wine were significantly higher than in the case of white and rosé wines, which can be explained by the differences in the production process and thus, the composition of red and white wine (Banc *et al.*, 2020; Paixão *et al.*, 2007). Differences in biogenic amines content were less pronounced since factors affecting their content include also the quality of raw materials, storage conditions and possible microbial contamination, which can result in the lack of a straightforward relationship between TBAC and the colour of wine (Papageorgiou *et al.*, 2018). It is also worth-noting that in most cases, results obtained for rosé wine were similar to those for white wine, which is in agreement with information found in the literature (Banc *et al.*, 2020; Nemzer *et al.*, 2022).

The Pearson correlation coefficient was calculated in order to evaluate the correlation between particu-

lar variables. Hue and density were excluded from the evaluation, since they strongly depend on the colour of wine. As can be seen in Figure 3, the highest value is obtained in the case of ABTS and TFC variables assays (0.84 for both smartphone-based and spectrophotometric methods). Furthermore, the charts obtained from both types of analysis are comparable indicating that the data obtained from a smartphone is similar to the one obtained from the standard methods for different assays of wines.

It is worth noting that no correlation between the results of ABTS and DPPH assays was observed. DPPH and ABTS assays are routinely used in wine analysis in order to assess its antioxidant properties, however, due to lack of standardization it is difficult to compare results obtained during different studies. Some studies suggest that DPPH is more sensitive to factors such as pH, however, it was found to be more suitable for studying non-polar compounds (Shalaby Shanab, 2013; Wołosiak *et al.*, 2022). On the other hand, while it was reported that ABTS assay is often unaffected by changes of e.g. pH and provides greater possibilities for research on polar compounds, it has to be preceded by 16 h incubation of ABTS solution which decreases its applicability (Habibatni *et al.*, 2016; Wołosiak *et al.*, 2022). Moreover, in many cases, DPPH and ABTS assays are used interchangeably as a means of total antioxidant activity determi-

Table 1: Results obtained using spectrophotometric and smartphone-based methods (n=5)

	Red (n=26)		White (n=19)		Rosé (n=4)	
	Average [mg/L]	Range [mg/L]	Average [mg/L]	Range [mg/L]	Average [mg/L]	Range [mg/L]
spectrophotometer						
TPC	1619	991 – 2425	474	91 – 1001	337	254 – 388
TFC	58	31 – 108	11	4.4 – 20.0	53	29 – 89
ABTS	269	95 – 551	34	<LOD – 77	46	11 – 87
TAC	55	28 – 94	-	<LOD	4.4	1.2 – 10.0
BAs	32	20 – 49	11	<LOD – 42	33	20 – 41
DPPH	44	1.4 – 144.9	145	1.7 – 88.6	73	69 – 85
Density	6.5	2.0 – 10.5	0.14	0.078 – 0.350	0.41	0.27 – 0.57
Hue	5.8	3.7 – 10.3	7.3	3.6 – 10.4	2.1	1.9 – 2.6
smartphone						
TPC	1615	878 – 2399	468	100 – 1003	349	254 – 386
TFC	58	33 – 110	11	4.5 – 20.4	54	30 – 87
ABTS	269	94 – 536	39	11 – 87	45	22 – 84
TAC	55	29 – 94	-	<LOD	4.3	1.2 – 10.3
BAs	33	21 – 47	11	0.93 – 41.00	27	19 – 41
DPPH	43	2.1 – 141.5	59	17 – 89	73	66 – 85

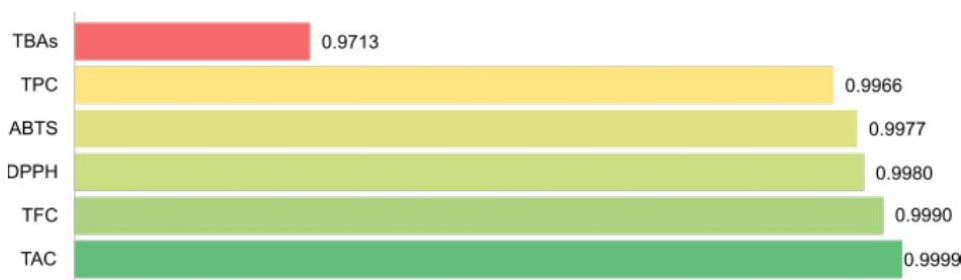

Figure 2: Person correlation coefficient between smartphone-based and spectrophotometric methods.

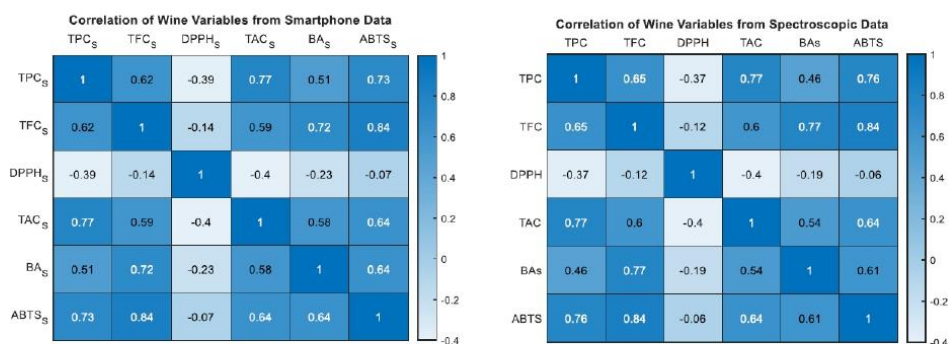

Figure 3: Correlation matrixes of variables measured using spectroscopic and smartphone-based methods.

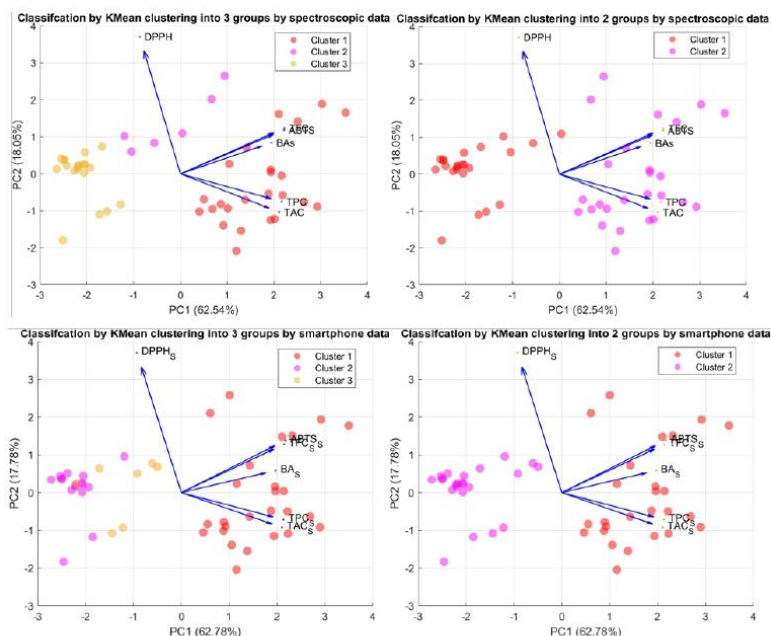

Figure 4: The biplots with KMean-clustering of the data obtained using spectrophotometric and smartphone-based methods. The classification was done into 3 and 2 groups (left and right, respectively).

nation, even though the discrepancies between results obtained under different experimental conditions have been widely reported (Apak *et al.*, 2016; Fernández-Pachón *et al.*, 2004). Nevertheless, it is important to remember that food is a complex matrix consisting of many compounds with antioxidation properties and numerous phytochemicals can present different antioxidant features at the same time, which complicates assessing the antioxidant capacity of food. Due to the existence of many variables influencing the antioxidant activity of food and, in consequence, particular assays' results, simultaneous use of multiple assays could be beneficial (Antolovich *et al.*, 2002; Fernández-Pachón *et al.*, 2004).

Additionally, an exploratory analysis was performed. The raw data from the spectroscopic and smartphone-based analysis were analysed using MATLAB R2023a version (9.14.0.2206 163) with pre-processing done by the autoscale method (procedure described in detail in Supplementary Material). The biplot with KMean-clustering of the data shows that the data divided into three clusters does not provide proper cluster formation, which would be close to the true class for white and rosé wines (Figure 4). Discrimination of groups is based on all variables beside DPPH with higher values resulting in positive PC. The classification using 2 groups has completely placed the rosé wines in white wines in 1 cluster while all others are el-

ements of red wine. The number of data points for rosé wine is probably not enough for KMean-clustering to categorize rosé as a separate cluster properly.

#### 4. Conclusions

New smartphone-based analytical methods for wine analysis were developed and fully validated. The proposed methods are inexpensive and uncomplicated, which improves their applicability. The use of smartphones as a means for detection facilitates the use of developed procedures outside the laboratory and without costly equipment, which significantly increases their accessibility. The obtained results confirmed that the proposed solution is suitable for the determination of bioactive compounds in liquid food samples, which means that it can be a useful tool for monitoring wine quality.

#### Acknowledgements

The authors would like to thank TiM S.A. for providing the wine samples.

#### CRediT author statement

Kaja Kalinowska: Conceptualization, Methodology, Investigation, Validation, Visualization, Writing

– original draft. Muhammad Saad Hussain: Investigation, Data Curation, Visualization, Writing – original draft. Marek Tobiszewski: Writing – review editing, Supervision.

## References

- Antolovich, M., Prenzler, P. D., Patsalides, E., McDonald, S., Robards, K. (2002). Methods for testing antioxidant activity. *Analyst*, 127(1), 183–198. <https://doi.org/10.1039/B009171P>
- Apak, R., Özyürek, M., Güçlü, K., Çapanoğlu, E. (2016). Antioxidant Activity/Capacity Measurement. 1. Classification, Physicochemical Principles, Mechanisms, and Electron Transfer (ET)-Based Assays. *Journal of Agricultural and Food Chemistry*, 64(5), 997–1027. <https://doi.org/10.1021/acs.jafc.5b04739>
- Banc, R., Loghin, F., Miere, D., Ranga, F., Socaciu, C. (2020). Phenolic composition and antioxidant activity of red, rosé and white wines originating from Romanian grape cultivars. *Notulae Botanicae Horti Agrobotanici Cluj-Napoca*, 48(2), Article 2. <https://doi.org/10.15835/nbha48211848>
- Chang, C.-C., Yang, M.-H., Wen, H.-M., Chern, J.-C. (2002). Estimation of Total Flavonoid Content in Propolis by Two Complementary Colorimetric Methods. *Journal of Food and Drug Analysis*, 10(3).
- Cliff, M. A., King, M. C., Schlosser, J. (2007). Anthocyanin, phenolic composition, colour measurement and sensory analysis of BC commercial red wines. *Food Research International*, 40(1), 92–100. <https://doi.org/10.1016/j.foodres.2006.08.002>
- Fernández-Pachón, M. S., Villaño, D., García-Parrilla, M. C., Troncoso, A. M. (2004). Antioxidant activity of wines and relation with their polyphenolic composition. *Analytica Chimica Acta*, 513(1), 113–118. <https://doi.org/10.1016/j.aca.2004.02.028>
- Habibatni, S., Miceli, N., Ginestra, G., Maameri, Z., Bisignano, C., Utczas, M., Mondello, L., Anwar, S., Benayache, S., Atrouz, D., Taviano, M. F. (2016). Antioxidant and antibacterial activity of extract and phases from stems of *Spartium junceum* L. growing in Algeria. *International Journal of Phytomedicine*, 8, 37–46.
- Kalinowska, K., Tobiszewski, M. (2023). Green, simple analytical method for total biogenic amines content determination in wine using spectrophotometry. *Food Chemistry*, 402, 134457. <https://doi.org/10.1016/j.foodchem.2022.134457>
- Kalinowska, K., Wojnowski, W., Tobiszewski, M. (2021). Smartphones as tools for equitable food quality assessment. *Trends in Food Science Technology*, 111, 271–279. <https://doi.org/10.1016/j.tifs.2021.02.068>
- Kalinowska, K., Wojnowski, W., Tobiszewski, M. (2023). Simple analytical method for total biogenic amines content determination in wine using a smartphone. *Analytical Methods*. <https://doi.org/10.1039/D2AY02035A>
- Lee, J., Durst, R. W., Wrolstad, R. E., Collaborators: (2005). Determination of Total Monomeric Anthocyanin Pigment Content of Fruit Juices, Beverages, Natural Colorants, and Wines by the pH Differential Method: Collaborative Study. *Journal of AOAC INTERNATIONAL*, 88(5), 1269–1278. <https://doi.org/10.1093/jaoac/88.5.1269>
- Miceli, N., Filocamo, A., Ragusa, S., Cacciola, F., Dugo, P., Mondello, L., Celano, M., Muggisano, V., Taviano, M. F. (2017). Chemical Characterization and Biological Activities of Phenolic-Rich Fraction from Cauline Leaves of *Isatis tinctoria* L. (Brassicaceae) Growing in Sicily, Italy. *Chemistry Biodiversity*, 14(8), e1700073. <https://doi.org/10.1002/cbdv.201700073>
- Nemzer, B., Kalita, D., Yashin, A. Y., Yashin, Y. I. (2022). Chemical Composition and Polyphenolic Compounds of Red Wines: Their Antioxidant Activities and Effects on Human Health—A Review. *Beverages*, 8(1), Article 1. <https://doi.org/10.3390/beverages8010001>
- Paixão, N., Perestrelo, R., Marques, J. C., Câmara, J. S. (2007). Relationship between antioxidant capacity and total phenolic content of red, rosé and white wines. *Food Chemistry*, 105(1), 204–214. <https://doi.org/10.1016/j.foodchem.2007.04.017>
- Papageorgiou, M., Lambropoulou, D., Morrison, C., Kłodzińska, E., Namieśnik, J., Płotka-Wasyłka, J. (2018). Literature update of analytical methods for biogenic amines determination in food and beverages. *TrAC Trends in Analytical Chemistry*, 98, 128–142. <https://doi.org/10.1016/j.trac.2017.11.001>
- Shalaby, E., Shanab, S. (2013). Antioxidant compounds, assays of determination and mode of action. *Afr. J. Pharm. Pharmacol.*, 7. Tchabo, W., Ma, Y., Kwaw, E., Zhang, H., Li, X.,

Afoakwah, N. A. (2017). Effects of Ultrasound, High Pressure, and Manosonication Processes on Phenolic Profile and Antioxidant Properties of a Sulfur Dioxide-Free Mulberry (*Morus nigra*) Wine. *Food and Bioprocess Technology*, 10(7), 1210–1223. <https://doi.org/10.1007/s11947-017-1892-5>

- Wołosiak, R., Drużyńska, B., Derwiaka, D., Piecyk, M., Majewska, E., Ciecierska, M., Worbiej, E., Pakosz, P. (2022). Verification of the Conditions for Determination of Antioxidant Activity by ABTS and DPPH Assays—A Practical Approach. *Molecules*, 27(1), Article 1. <https://doi.org/10.3390/molecules27010050>



## Supplementary Materials

### Simple smartphone-based methods for the determination of bioactive compounds in wine

Kaja KALINOWSKA<sup>\*a</sup>, Muhammad Saad HUSSAIN<sup>b</sup>, Marek TOBISZEWSKI<sup>a</sup>

<sup>a</sup> Gdańsk University of Technology, Faculty of Chemistry, Department of Analytical Chemistry  
11/12 Gabriela Narutowicza Street, 80-233 Gdańsk, Poland

<sup>b</sup>  
Corresponding author: kaja.kalinowska@pg.edu.pl

**Table S1.** Wine samples characteristics.

Name	Colour	Sweetness	Country of origin	Grape variety	Alcohol content [%]
RAF	red	semidry	Republic of South Africa	Pinotage	13.0-13.5
RAP	rosé	semidry	Italy	Merlot, Primitivo, Negroamaro	14.5
RBL	red	semisweet	Moldova	Cabernet Sauvignon, Merlot	13.0
RBO	red	dry	Spain	Tempranillo	13.5
RBOR	red	dry	France	Merlot, Cabernet Sauvignon	13.0
RC	red	semidry	Australia	Cabernet Sauvignon	13.5
RCHI	red	semidry	Chile	Cabernet Sauvignon	13.0
RFIN	red	dry	Spain	Tempranillo	13.5
RG	red	semisweet	Spain	Merlot	13.5
RGAM	red	semisweet	Georgia	Saperavi	12.5
RGE	red	sweet	Israel	Cabernet Sauvignon	12.0
RGRA	red	dry	France	Malbec	13.0
RHAR	red	dry	Argentina	Malbec	13.0
RLE	red	dry	France	Grenache, Syrah, Mourvedre	13.0
RLGR	red	dry	France	Cabernet Sauvignon, Syrah	13.0-13.5
RN	red	semidry	Italy	Uva di Troia	14.5
RNAM	red	dry	Argentina	Shiraz	12.5-13.5
ROA	red	semisweet	USA	n/a	12.5
RoAUR	rosé	semidry	Moldova	Merlot	13.5
RoOAK	rosé	semisweet	USA	n/a	11.0-11.5
RoPAX	rosé	semidry	Portugal	Tinta Roriz	12.5
RoPOR	rosé	dry	Portugal	Pinot Noir, Shiraz, Tinta Roriz	11.5-12.0
RPA	red	dry	Chile	Cabernet Sauvignon	13.5
RPAS	red	sweet	Moldova	Cabernet Sauvignon	16.0
RPOR	red	semisweet	Portugal	Touriga Nacional, Tinta Roriz, Castelao, Caladoc, Alicante Bouschet	12.5
RPRI	red	semisweet	Italy	Primitivo	13.0
RPUG	red	semidry	Portugal	Primitivo	15.0
RSUG	red	semidry	Spain	Cabernet Sauvignon	13.5
RSV	red	dry	Spain	Tempranillo, Syrah, Cabernet Sauvignon	13.5
RVI	red	dry	Republic of South Africa	Pinotage	13.0
WAF	white	semidry	Republic of South Africa	Chenin Blanc	12.5

WBIC	white	dry	Chile	Chardonnay	12.5
WBOR	white	semidry	France	Muscadelle, Sauvignon Blanc, Semillon	12.7
WCAV	white	semidry	Spain	Macabeo, Parellada	11.5
WCOD	white	dry	Italy	Fiano	12.5
WDOK	white	semisweet	Moldova	Chardonnay, Pinot Blanc	12.0
WGEN	white	sweet	Israel	Emerald Riesling, Colombard	12.0
WLAZ	white	dry	Republic of South Africa	Chenin Blanc	13.5
WMOS	white	sweet	France	Muscat	13.0
WPOR	white	semidry	Portugal	n/a	11.0
WPORT	white	semisweet	Portugal	Chardonnay, Moscatel, Alvarinho, Fernao Pires, Arinto	11.5-12.0
WPRO	white	dry	Italy	Glera	11.0
WQUAI	white	dry	Australia	Chardonnay	n/a
WSUE	white	dry	Spain	Macabeo, Viognier, Riesling	12.0
WSUER	white	sweet	Spain	Airen, Moscatel	-
WTIER	white	semidry	Chile	Pedro Jimenez, Sauvignon Blanc, Chardonnay	12.0-12.5
WTOR	white	semidry	Argentina	Torrontes	13.0
WVEN	white	dry	Portugal	Garganega, Chardonnay	12.5
WVIO	white	dry	France	Viognier	13.0

**Table S2.** LEDs used for different assays

Assay	Channels	LED
Phenolic content	R	880 nm IR & 660 nm red SMD LED (OSIRCAS2C1A-880 nm, Optosupply Ltd, Honk Kong)
Flavonol content	R+B	435 nm UV-L LED (PK2N-3LLE-L, ProLight Opto Technology Corp., China)
DPPH radical scavenging activity	R+G	523 nm LED (LT A67C-T2V1-35, Osram, Germany)
Antioxidant capacity	R	880 nm IR & 660 nm red SMD LED (OSIRCAS2C1A-880 nm, Optosupply Ltd, Honk Kong)
Anthocyanin content	G+B	523 nm LED (LT A67C-T2V1-35, Osram, Germany)
Biogenic amines content	R	880 nm IR & 660 nm red SMD LED (OSIRCAS2C1A-880 nm, Optosupply Ltd, Honk Kong)



### **Validation description**

Linearity was examined by the application of different concentrations of standards in wine. Limits of detection (LOD) and limits of quantification (LOQ) were assessed based on the calibration curves and five blank samples, with calculations made using the following equations:  $LOD = 3 \cdot (SD/a)$  and  $LOQ = 10 \cdot (SD/a)$ , where SD is the standard deviation and a is the slope of the calibration curve (Mörschbacher et al., 2018). The intra-day repeatability ( $RSD_I$ ) was estimated using five replicates of wine samples spiked at two levels and analysed on the same day, while inter-day ( $RSD_R$ ) repeatability was determined using results of the analysis of samples from three different days over three weeks (day 1, 7 and 15). Accuracy of the method was determined by recovery test, samples were spiked with the known concentration of standard, difference between the absorbance of the spiked and unspiked sample was compared with the concentration of the spike itself (n=5).



**Table S3.** Analytical figures of merit for smartphone-based and spectrophotometric methods.

Assay	Concentration range [mg/L]	Linearity ( $R^2$ )	Inter-day repeatability, n=5 (% RSD <sub>R</sub> )		Recovery (%)	Intra-day repeatability, n=5 (% RSD <sub>I</sub> )		LOD [mg/L]	LOQ [mg/L]
Smartphone									
Phenolic content	10 - 200	0.9860	30 mg/L 2.0	60 mg/L 3.4	96.2±3.6	30 mg/L 1.7	60 mg/L 2.7	2.3	7.7
Flavonol content	2 - 200	0.9952	50 mg/L 3.0	150 mg/L 3.2	102.0±2.4	50 mg/L 1.9	150 mg/L 2.6	0.58	1.9
DPPH radical scavenging activity	2-100	0.9975	25 mg/L 3.4	75 mg/L 3.3	99.4±3.7	25 mg/L 2.5	75 mg/L 2.2	0.51	1.7
Antioxidant capacity	2-100	0.9957	25 mg/L 3.6	75 mg/L 4.2	99.4±3.7	25 mg/L 2.2	75 mg/L 2.8	0.26	0.86
Anthocyanin content	1-100	0.9956	25 mg/L 2.1	75 mg/L 3.4	100.9±3.1	25 mg/L 1.1	75 mg/L 2.7	0.30	0.99
Biogenic amines content	1 - 100	0.9981	30 mg/L 2.4	60 mg/L 3.9	96.2±3.6	30 mg/L 2.3	60 mg/L 3.6	0.28	0.94
Spectrophotometry									
Phenolic content	10 - 200	0.9931	50 mg/L 2.9	150 mg/L 3.0	102.7±1.1	50 mg/L 2.1	150 mg/L 2.8	2.4	7.9
Flavonol content	2 - 100	0.9963	25 mg/L 2.5	75 mg/L 2.4	101.5±3.0	25 mg/L 2.4	75 mg/L 1.6	0.56	1.9
DPPH radical scavenging activity	2 - 100	0.9864	25 mg/L 2.3	75 mg/L 2.0	99.2±3.3	25 mg/L 1.8	75 mg/L 1.9	0.57	1.9
Antioxidant capacity	1 - 100	0.9979	25 mg/L 4.2	75 mg/L 1.0	99.4±1.7	25 mg/L 2.9	75 mg/L 0.7	0.25	0.83
Biogenic amines content	1 - 20	0.9906	7 mg/L 1.8	15 mg/L 1.8	99.7±2.0	7 mg/L 2.2	15 mg/L 1.7	0.29	0.98
	20 - 100	0.9933	30 mg/L 2.4	60 mg/L 2.0	101.2±3.5	30 mg/L 1.9	60 mg/L 1.8	1.4	4.5

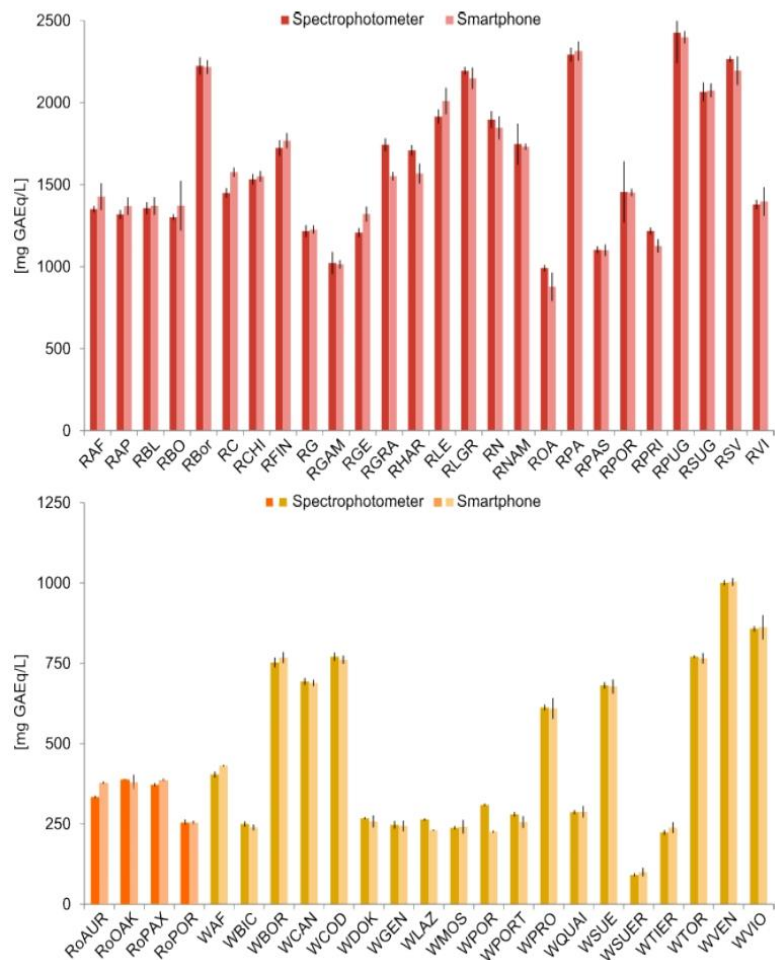

**Figure S1.** Results of total phenolic content determination in the red, rosé, and white wine (depicted in red, orange and yellow, respectively).

An exploratory analysis was performed. The raw data from the spectroscopic and smartphone-based analysis were analyzed using MATLAB. In the case of both methods, 3 and more principal components cumulative explained more than 80% of the variance, hence, it is the optimal number of selected principal components and was used for further analysis (Figure S2.).

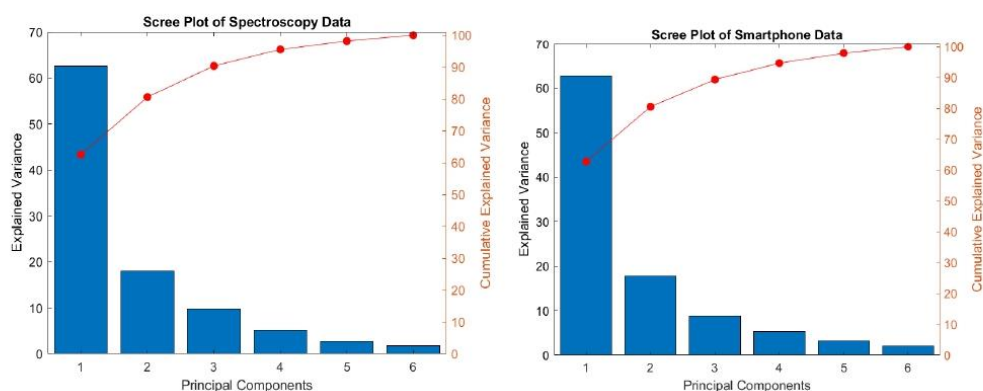

**Figure S2.** Scree plots for the data obtained using spectrophotometric and smartphone-based methods.

The biplot obtained from PCA analysis of auto-scaled data shows the clusters' formation and the clouds around them represent the scaled confidence interval obtained by 5 replicates of each sample (Figure S3.). Red wine is completely separated from others in all cases while rosé and white wines seem to merge with each other. In most cases, the data points of rosé wine are close to each other but they are also closer to the cluster of white wine.

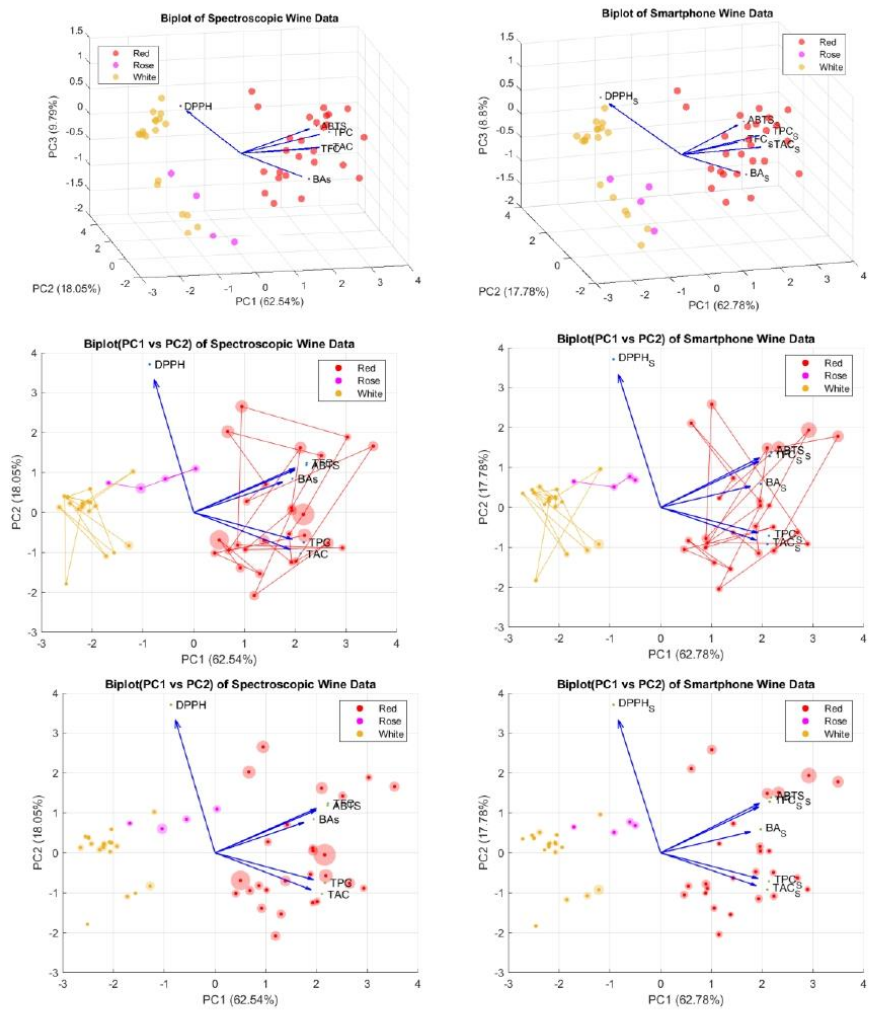

**Figure S3.** The PCA-based biplot of the data obtained using spectrophotometric and smartphone-based methods. The cloud around points represent the scaled confidence interval obtained by 5 replicates of each sample.

## References

Mörschbacher, A. P., Dullius, A., Dullius, C. H., Bandt, C. R., Kuhn, D., Brietzke, D. T., Malmann Kuffel, F. J., Etgeton, H. P., Altmayer, T., Gonçalves, T. E., Oreste, E. Q., Ribeiro, A. S., de Souza, C. F. V., & Hoehne, L. (2018). Validation of an analytical method for the quantitative determination of selenium in bacterial biomass by ultraviolet–visible spectrophotometry. *Food Chemistry*, 255(April 2017), 182–186. <https://doi.org/10.1016/j.foodchem.2018.02.057>

## References

- [1] Lowder, S. K., Sánchez, M. V., Bertini, R. (2019) Farms, family farms, farmland distribution and farm labour: What do we know today? In: *FAO Agricultural Development Economics* No. 854-2020-093.
- [2] Food and Agriculture Organization of the United Nations & International Organisation of Vine and Wine (2016) Non-alcoholic products of the vitivinicultural sector intended for human consumption. Accessed: May 26, 2023. [Online]. Available: <https://www.fao.org/3/i7042e/i7042e.pdf>
- [3] International Organisation of Vine and Wine (2023) State of the World Vine and Wine Sector in 2022. Accessed: May 25, 2023. [Online]. Available: [https://www.oiv.int/sites/default/files/documents/2023\\_SWVWS\\_report\\_EN.pdf](https://www.oiv.int/sites/default/files/documents/2023_SWVWS_report_EN.pdf)
- [4] Nemzer, B., Kalita, D., Yashin, A. Y., Yashin, Y. I. (2022) Chemical Composition and Polyphenolic Compounds of Red Wines: Their Antioxidant Activities and Effects on Human Health—A Review, *Beverages*, 8 (1), DOI: 10.3390/beverages8010001.
- [5] German, J. B., Walzem, R. L. (2000) The Health Benefits of Wine, *Annual Review of Nutrition*, 20 (1), DOI: 10.1146/annurev.nutr.20.1.561.
- [6] Banc, R., Loghin, F., Miere, D., Ranga, F., Socaciu, C., (2020) Phenolic composition and antioxidant activity of red, rosé and white wines originating from Romanian grape cultivars, *Notulae Botanicae Horti Agrobotanici Cluj-Napoca*, 48 (2), DOI: 10.15835/nbha48211848.
- [7] Gawel, R., Smith, P. A., Cicerale, S., Keast, R. (2018) The mouthfeel of white wine, *Critical Reviews in Food Science and Nutrition*, 58 (17), DOI: 10.1080/10408398.2017.1346584.
- [8] Cordente, A. G., Espinase Nandorfy, D., Solomon, M., Schulkin, A., Kolouchova, R., Francis, I. L., & Schmidt, S. A. G. (2021) Aromatic Higher Alcohols in Wine: Implication on Aroma and Palate Attributes during Chardonnay Aging, *Molecules*, 26 (16), DOI: 10.3390/molecules26164979.
- [9] Butnariu, M., Butu, A. (2019) Qualitative and Quantitative Chemical Composition of Wine, In: *Quality Control in the Beverage Industry*, Elsevier, DOI: 10.1016/B978-0-12-816681-9.00011-4.
- [10] López-Vélez, M., Martínez-Martínez, F., Del Valle-Ribes, C. (2003) The Study of Phenolic Compounds as Natural Antioxidants in Wine, *Critical Reviews in Food Science and Nutrition*, 43 (3), DOI: 10.1080/10408690390826509.
- [11] Gómez-Alonso, S., García-Romero, E., Hermosín-Gutiérrez, I. (2007) HPLC analysis of diverse grape and wine phenolics using direct injection and multidetection by DAD and fluorescence, *Journal of Food Composition and Analysis*, 20 (7), DOI: 10.1016/j.jfca.2007.03.002.

- [12] Goldberg, D. M., Ng, E., Yan, J., Karumanchiri, A., Soleas, G. J., Diamandis, E. P. (1996) Regional differences in resveratrol isomer concentrations of wines from various cultivar, *Journal of Wine Research*, 7 (1), DOI: 10.1080/09571269608718057.
- [13] Castillo-Muñoz, N., Gómez-Alonso, S., García-Romero, E., Hermosín-Gutiérrez, I. (2007) Flavonol Profiles of *Vitis vinifera* Red Grapes and Their Single-Cultivar Wines, *Journal of Agricultural and Food Chemistry*, 55 (3), DOI: 10.1021/jf062800k.
- [14] de Villiers, A., Vanhoenacker, G., Majek, P., Sandra, P. (2004) Determination of anthocyanins in wine by direct injection liquid chromatography–diode array detection–mass spectrometry and classification of wines using discriminant analysis, *Journal of Chromatography A*, 1054 (1), DOI: 10.1016/j.chroma.2004.07.087.
- [15] Versari, A., du Toit, W., Parpinello, G. P. (2013) Oenological tannins: a review, *Australian Journal of Grape and Wine Research*, 19 (1), DOI: 10.1111/ajgw.12002.
- [16] Ma, W., Guo, A., Zhang, Y., Wang, H., Liu, Y., Li, H. (2014) A review on astringency and bitterness perception of tannins in wine, *Trends in Food Science and Technology*, 40 (1), DOI: 10.1016/j.tifs.2014.08.001.
- [17] Papageorgiou, M., Lambropoulou, D., Morrison, C., Kłodzińska, E., Namieśnik, J., Płotka-Wasyłka, J. (2018) Literature update of analytical methods for biogenic amines determination in food and beverages, *Trends in Analytical Chemistry*, 98, DOI: 10.1016/j.trac.2017.11.001.
- [18] Ancín-Azpilicueta, C., Jiménez-Moreno, N., Sola - Larrañaga, C. (2019) Wine, In: *Innovations in Traditional Foods*, Elsevier, DOI: 10.1016/B978-0-12-81488-7.00009-5.
- [19] Önal, A. (2007) A review: Current analytical methods for the determination of biogenic amines in foods, *Food Chemistry*, 103 (4), DOI: 10.1016/j.foodchem.2006.08.028.
- [20] Vinci, G., Antonelli, M. L. (2002) Biogenic amines: quality index of freshness in red and white meat, *Food Control*, 13 (8), DOI: 10.1016/S0956-7135(02)00031-2.
- [21] Wojnowski, W., Kalinowska, K., Majchrzak, T., Płotka-Wasyłka, J., Namieśnik, J. (2019) Prediction of the Biogenic Amines Index of Poultry Meat Using an Electronic Nose, *Sensors*, 19 (7), DOI: 10.3390/s19071580.
- [22] Arulkumar, A., Paramithiotis, S., Paramasivam, S. (2023) Biogenic amines in fresh fish and fishery products and emerging control, *Aquaculture and Fisheries*, 8 (4), DOI: 10.1016/j.aaf.2021.02.001.
- [23] Fabjanowicz, M., Różańska, A., Kalinowska, K., Płotka-Wasyłka, J. (2022) Miniaturized, green salting-out liquid–liquid microextraction coupled with GC–MS used to evaluate biogenic amines in wine samples, *Microchemical Journal*, 180, DOI: 10.1016/j.microc.2022.107616.



- [24] Martuscelli, M., Arfelli, G., Manetta, A. C., Suzzi, G. (2013) Biogenic amines content as a measure of the quality of wines of Abruzzo (Italy), *Food Chemistry*, 140 (3), DOI: 10.1016/j.foodchem.2013.01.008.
- [25] de Villiers, A., Alberts, P., Tredoux, A. G. J., Nieuwoudt, H. H. (2012) Analytical techniques for wine analysis: An African perspective; a review, *Analytica Chimica Acta*, 730, DOI: 10.1016/j.aca.2011.11.064.
- [26] Dias, J. V., Nunes, M. da G. P., Pizzutti, I. R., Reichert, B., Jung, A. A., Cardoso, C. D. (2019) Simultaneous determination of pesticides and mycotoxins in wine by direct injection and liquid chromatography-tandem mass spectrometry analysis, *Food Chemistry*, 293, DOI: 10.1016/j.foodchem.2019.04.088.
- [27] He, J., Zhang, B., Zhang, H., Hao, L. L., Ma, T. Z., Wang, J., Han, S. Y. (2019) Monitoring of 49 Pesticides and 17 Mycotoxins in Wine by QuEChERS and UHPLC-MS/MS Analysis, *Journal of Food Science*, 84 (9), DOI: 10.1111/1750-3841.14695.
- [28] Peres, R. G., Moraes, E. P., Micke, G. A., Tonin, F. G., Tavares, M. F. M., Rodriguez-Amaya, D. B. (2009) Rapid method for the determination of organic acids in wine by capillary electrophoresis with indirect UV detection, *Food Control*, 20 (6), DOI: 10.1016/j.foodcont.2008.08.004.
- [29] Rovio, S., Sirén, K., Sirén, H. (2011) Application of capillary electrophoresis to determine metal cations, anions, organic acids, and carbohydrates in some Pinot Noir red wines, *Food Chemistry*, 124 (3) DOI: 10.1016/j.foodchem.2010.07.044.
- [30] Castiñeira, A., Peña, R. M., Herrero, C., García-Martín, S. (2002) Analysis of Organic Acids in Wine by Capillary Electrophoresis with Direct UV Detection, *Journal of Food Composition and Analysis*, 15 (3) DOI: 10.1006/jfca.2002.1056.
- [31] Ekere, N. R., Ngang, B. U., Onoja, U. S. (2022) Evaluation of metal contents of selected red wines consumed in South-East Nigeria, *Journal of Wine Research*, 33 (2), DOI: 10.1080/09571264.2021.2004540.
- [32] Santos Neto, J. H., Porto, I. S. A., Schneider, M. P., dos Santos, A. M. P., Gomes, A. A., Ferreira, S. L. C. (2019) Speciation analysis based on digital image colorimetry: Iron (II/III) in white wine, *Talanta*, 194, DOI: 10.1016/j.talanta.2018.09.102.
- [33] Bronzi, B., Brilli, C., Beone, G. M., Fontanella, M. C., Ballabio, D., Todeschini, R., Consonni, V., Grisoni, F., Parri, F., Buscema, M. (2020) Geographical identification of Chianti red wine based on ICP-MS element composition, *Food Chemistry*, 315, DOI: 10.1016/j.foodchem.2020.126248.
- [34] Pérez-Álvarez, E. P., Garcia, R., Barrulas, P., Dias, C., Cabrita, M. J., Garde-Cerdán, T. (2019) Classification of wines according to several factors by ICP-MS multi-element analysis, *Food Chemistry*, 270, DOI: 10.1016/j.foodchem.2018.07.087.

- [35] Solovyev, P. A., Fauhl-Hassek, C., Riedl, J., Esslinger, S., Bontempo, L., Camin, F. (2021) NMR spectroscopy in wine authentication: An official control perspective, *Comprehensive Reviews in Food Science and Food Safety*, 20 (2), DOI: 10.1111/1541-4337.12700.
- [36] Berbegal, C., Khomenko, I., Russo, P., Spano, G., Fragasso, M., Biasioli, F., Capozzi, V. (2020) PTR-ToF-MS for the Online Monitoring of Alcoholic Fermentation in Wine: Assessment of VOCs Variability Associated with Different Combinations of *Saccharomyces*/Non-*Saccharomyces* as a Case-Study, *Fermentation*, 6 (2), DOI: 10.3390/fermentation6020055.
- [37] Gardiman, M., De Rosso, M., De Marchi, F., Flamini, R. (2023) Metabolomic profiling of different clones of *Vitis vinifera* L. cv. "Glera" and "Glera lunga" grapes by high-resolution mass spectrometry, *Metabolomics*, 19 (4) DOI: 10.1007/s11306-023-01997-w.
- [38] Basalekou, M., Pappas, C., Tarantilis, P. A., Kallithraka, S., Wine Authenticity and Traceability with the Use of FT-IR, *Beverages*, 6 (2) DOI: 10.3390/beverages6020030.
- [39] Geană, E.-I., Ciucure, C. T., Apetrei, C., Artem, V. (2019) Application of Spectroscopic UV-Vis and FT-IR Screening Techniques Coupled with Multivariate Statistical Analysis for Red Wine Authentication: Varietal and Vintage Year Discrimination, *Molecules*, 24 (22) DOI: 10.3390/molecules24224166.
- [40] Mendes, E., Duarte, N. (2021) Mid-Infrared Spectroscopy as a Valuable Tool to Tackle Food Analysis: A Literature Review on Coffee, Dairies, Honey, Olive Oil and Wine, *Foods*, 10 (2), DOI: 10.3390/foods10020477.
- [41] Pereira, A. C., Reis, M. S., Saraiva, P. M., Marques, J. C. (2011) Development of a fast and reliable method for long- and short-term wine age prediction, *Talanta*, 86, DOI: 10.1016/j.talanta.2011.09.016.
- [42] García-Guzmán, J. J., Hernández-Artiga, M. P., Palacios-Ponce de León, L., Bellido-Milla, D. (2015) Selective methods for polyphenols and sulphur dioxide determination in wines, *Food Chemistry*, 182, DOI: 10.1016/j.foodchem.2015.02.101.
- [43] Rodríguez-Méndez, M. L., De Saja, J. A., González-Antón, R., García-Hernández, C., Medina-Plaza, C., García-Cabezón, C., Martín-Pedrosa, F. (2016) Electronic Noses and Tongues in Wine Industry, *Frontiers in Bioengineering and Biotechnology*, 4, DOI: 10.3389/fbioe.2016.00081.
- [44] Wojnowski, W., and Kalinowska, K., Machine learning and electronic noses for medical diagnostics (2021) In: *Artificial Intelligence in Medicine*. DOI: 10.1007/978-3-030-58080-3\_329-1.
- [45] García, M., Alexandre M., Gutiérrez, J., Horrillo, M. C. (2006) Electronic nose for wine discrimination, *Sensors and Actuators B: Chemical*, 113 (2), DOI: 10.1016/j.snb.2005.03.078.

- [46] Kalinowska, K., Wojnowski, W., Tobiszewski, M. (2021) Smartphones as tools for equitable food quality assessment, *Trends in Food Science and Technology*, 111, DOI: 10.1016/j.tifs.2021.02.068.
- [47] Nelis, J. L. D., Tsagkaris, A. S., Dillon, M. J., Hajslova, J., Elliott, C. T. (2020) Smartphone-based optical assays in the food safety field, *Trends in Analytical Chemistry*, 129, DOI: 10.1016/j.trac.2020.115934.
- [48] Płotka-Wasyłka, J., Fabjanowicz, M., Kalinowska, K., Namieśnik, J. (2019). History and Milestones of Green Analytical Chemistry. In: *Green Analytical Chemistry. Green Chemistry and Sustainable Technology*. DOI: 10.1007/978-981-13-9105-7\_1.
- [49] Armenta, S., Esteve-Turrillas, F. A., Garrigues, S., de la Guardia, M. (2023) Chapter 1 - Green Analytical Chemistry: concepts, evolution, and recent developments', In: *Green Approaches for Chemical Analysis*, Gionfriddo, E. (Ed.), Elsevier, DOI: 10.1016/B978-0-12-822234-8.00006-8.
- [50] de Marco, B. A., Rechelo, B. S., Tótolí, E. G., Kogawa, A. C., Salgado, H. R. N. (2019) Evolution of green chemistry and its multidimensional impacts: A review', *Saudi Pharmaceutical Journal*, 27 (1), DOI: 10.1016/j.jsps.2018.07.011.
- [51] de la Guardia, M., Armenta, S. (2011) Chapter 1 - Origins of Green Analytical Chemistry, In: *Comprehensive Analytical Chemistry*, de la Guardia, M., Armenta, S. (Eds.), 57, Elsevier, DOI: 10.1016/B978-0-444-53709-6.00001-X.
- [52] Gałuszka, A., Migaszewski, Z. M., Konieczka, P., Namieśnik, J. (2012) Analytical Eco-Scale for assessing the greenness of analytical procedures, *Trends in Analytical Chemistry*, 37, DOI: 10.1016/j.trac.2012.03.013.
- [53] Koel, M. (2016) Do we need Green Analytical Chemistry?, *Green Chemistry*, 18 (4), DOI: 10.1039/C5GC02156A.
- [54] Marcinkowska, R., Namieśnik, J., Tobiszewski, M. (2019) Green and equitable analytical chemistry, *Current Opinion in Green and Sustainable Chemistry*, 19, DOI: 10.1016/j.cogsc.2019.04.003.
- [55] Tsagkaris, A. S., Nelis, J. L. D., Campbell, K., Elliott, C. T., Pulkrabova, J., Hajslova, J. (2023) Chapter 8 - Smartphone and microfluidic systems in medical and food analysis, In: *Microfluidic Biosensors*, Mak, W. C. and Pui Ho, A. H. (Eds.), Academic Press, DOI: 10.1016/B978-0-12-823846-2.00002-X.
- [56] Kalinowska, K., Bystrzanowska, M., Tobiszewski, M., (2021) Chemometrics approaches to green analytical chemistry procedure development, *Current Opinion in Green and Sustainable Chemistry*, 30, 100498, DOI: 10.1016/j.cogsc.2021.100498.
- [57] Chemat, F., Garrigues, S., de la Guardia, M. (2019) Portability in analytical chemistry: a green and democratic way for sustainability, *Current Opinion in Green and Sustainable Chemistry*, 19, DOI: 10.1016/j.cogsc.2019.07.007.

- [58] Reinholds, I., Bartkevics, V., Silvis, I. C. J., van Ruth, S. M., Esslinger, S. (2015) Analytical techniques combined with chemometrics for authentication and determination of contaminants in condiments: A review, *Journal of Food Composition and Analysis*, 44, DOI: 10.1016/j.jfca.2015.05.004.
- [59] McGonigle, A. J., Wilkes, T. C., Pering, T. D., Willmott, J. R., Cook, J. M., Mims III, F. M., Parisi, A. V. (2018) Smartphone spectrometers, *Sensors*, 18 (1), DOI: 10.3390/s18010223.
- [60] Tsagkaris, A. S., Nelis, J. L. D., Ross, G. M. S., Jafari, S., Guercetti, J., Kopper, K., Zhao, Y., Rafferty, K., Salvador, J. P., Migliorelli, D., Salentijn, G. IJ., Campbell, K., Marco, M. P., Elliot, C. T., Nielen, M. W. F., Pulkrabova, J., Hajslova J. (2019) Critical assessment of recent trends related to screening and confirmatory analytical methods for selected food contaminants and allergens, *Trends in Analytical Chemistry*, 121, DOI: 10.1016/j.trac.2019.115688.
- [61] Triki, M., Herrero, A., Jiménez-Colmenero, F., Ruiz-Capillas, C. (2018) Quality Assessment of Fresh Meat from Several Species Based on Free Amino Acid and Biogenic Amine Contents during Chilled Storage, *Foods*, 7 (9), DOI: 10.3390/foods7090132.
- [62] Rateni, G., Dario, P., Cavallo, F. (2017) Smartphone-Based Food Diagnostic Technologies: A Review, *Sensors*, 17 (6), DOI: 10.3390/s17061453.
- [63] Wojnowski, W., Tobiszewski, M., Pena-Pereira, F., Psillakis, E. (2022) AGREEprep – Analytical greenness metric for sample preparation, *Trends in Analytical Chemistry*, 149, DOI: 10.1016/j.trac.2022.116553.
- [64] Sheoran, S., Nidhi, P., Kumar, V., Singh, G., Lal, U. R., Sourirajan, A., Dev, K. (2019) Altitudinal variation in gallic acid content in fruits of *Phyllanthus emblica* L. and its correlation with antioxidant and antimicrobial activity, *Vegetos*, 32 (3), DOI: 10.1007/s42535-019-00048-x.
- [65] Paixão, N., Perestrelo, R., Marques, J. C., Câmara, J. S. (2007) Relationship between antioxidant capacity and total phenolic content of red, rosé and white wines, *Food Chemistry*, 105 (1), DOI: 10.1016/j.foodchem.2007.04.017.
- [66] Badea, M., di Modugno, F., Floroian, L., Tit, D. M., Restani, P., Bungau, S., Iovan, C., Badea, Aleya, G. E., L., (2019) Electrochemical strategies for gallic acid detection: Potential for application in clinical, food or environmental analyses', *Science of The Total Environment*, 672, DOI: 10.1016/j.scitotenv.2019.03.404.
- [67] Rauscher-Gabernig, E., Grossgut, R., Bauer, F., Paulsen, P. (2009) Assessment of alimentary histamine exposure of consumers in Austria and development of tolerable levels in typical foods, *Food Control*, 20 (4), DOI: 10.1016/j.foodcont.2008.07.011.

- [68] Visciano, P., Schirone, M., Tofalo, R., Suzzi, G. (2014) Histamine poisoning and control measures in fish and fishery products, *Frontiers in Microbiology*, 5, DOI: 10.3389/fmicb.2014.00500.
- [69] Lu, Y., Shi, Z., Liu, Q. (2019) Smartphone-based biosensors for portable food evaluation, *Current Opinion in Food Science*, 28, DOI: 10.1016/j.cofs.2019.09.003.
- [70] Wojnowski, W., Marć, M., Kalinowska, K., Kosmela, P., Zabiegała, B. (2022) Emission Profiles of Volatiles during 3D Printing with ABS, ASA, Nylon, and PETG Polymer Filaments, *Molecules*, 27 (12), DOI: 10.3390/molecules27123814.
- [71] Wojnowski, W., Kalinowska, K., Majchrzak, T., Zabiegała, B. (2022) Real-time monitoring of the emission of volatile organic compounds from polylactide 3D printing filaments, *Science of The Total Environment*, 805, DOI: 10.1016/j.scitotenv.2021.150181.
- [72] Wojnowski, W., Kalinowska, K., Gebicki, J., Zabiegała, B. (2020) Monitoring the BTEX Volatiles during 3D Printing with Acrylonitrile Butadiene Styrene (ABS) Using Electronic Nose and Proton Transfer Reaction Mass Spectrometry, *Sensors*, 20 (19), DOI: 10.3390/s20195531.
- [73] Różańska, A., Fabjanowicz, M., Kalinowska, K., Polkowska, Ż., Płotka-Wasyłka, J. (2022) Green, simple analytical method for biogenic amines determination in fruit juice samples using salting-out assisted liquid-liquid microextraction and gas chromatography-mass spectrometry, *Food Chemistry*, 384, DOI: 10.1016/j.foodchem.2022.132557.
- [74] Cliff, M. A., King, M. C., Schlosser, J. (2007) Anthocyanin, phenolic composition, colour measurement and sensory analysis of BC commercial red wines, *Food Research International*, 40 (1), DOI: 10.1016/j.foodres.2006.08.002.



## List of scientific achievements

### JCR-listed publications

*Citations based on the Scopus, accessed on 16.06.2023*

Kalinowska, K., Wojnowski, W., Tobiszewski, M., Simple analytical method for total biogenic amines content determination in wine using a smartphone (2023) *Analytical Methods*, 15 (11), 1395. DOI: 10.1039/d2ay02035a. IF: 3,532, Q2.

Kalinowska, K., Tobiszewski, M., Green, simple analytical method for total biogenic amines content determination in wine using spectrophotometry (2023) *Food Chemistry*, 402, 134457. DOI: 10.1016/j.foodchem.2022.134457. IF: 9.231, Q1, 1 citation.

Fabjanowicz, M., Różańska, A., Kalinowska, K., Płotka-Wasyłka, J., Miniaturized, green salting-out liquid-liquid microextraction coupled with GC-MS used to evaluate biogenic amines in wine samples (2022) *Microchemical Journal*, 180, 107616, DOI: 10.1016/j.microc.2022.107616. IF: 5.304, Q1, 3 citations.

Różańska, A., Fabjanowicz, M., Kalinowska, K., Polkowska, Płotka-Wasyłka, J., Green, simple analytical method for biogenic amines determination in fruit juice samples using salting-out assisted liquid-liquid microextraction and gas chromatography-mass spectrometry (2022) *Food Chemistry*, 384, 132557, DOI: 10.1016/j.foodchem.2022.132557. IF 9.231, Q1, 9 citations.

Wojnowski, W., Marć, M., Kalinowska, K., Kosmela, P., Zabiegała, B., Emission Profiles of Volatiles during 3D Printing with ABS, ASA, Nylon, and PETG Polymer Filaments (2022) *Molecules*, 27 (12), 3814, DOI: 10.3390/molecules27123814. IF: 4.927, Q2, 1 citation.

Wojnowski, W., Kalinowska, K., Majchrzak, T., Zabiegała, B., Real-time monitoring of the emission of volatile organic compounds from polylactide 3D printing filaments (2022) *Science of the Total Environment*, 805, 150181, DOI: 10.1016/j.scitotenv.2021.150181. IF: 10.754, Q1, 9 citations.

Sajid, M., Kalinowska, K., Płotka-Wasyłka, J., Ferrofluids based analytical extractions and evaluation of their greenness (2021) *Journal of Molecular Liquids*, 339, 116901, DOI: 10.1016/j.molliq.2021.116901. IF: 6.633, Q2, 7 citations.

Kalinowska, K., Bystrzanowska, M., Tobiszewski, M., Chemometrics approaches to green analytical chemistry procedure development (2021) *Current Opinion in Green and Sustainable Chemistry*, 30, 100498, DOI: 10.1016/j.cogsc.2021.100498. IF: 8.843, Q1, 11 citations.

Kalinowska, K., Wojnowski, W., Tobiszewski, M., Smartphones as tools for equitable food quality assessment (2021) *Trends in Food Science*

*and Technology*, 111, 271. DOI: 10.1016/j.tifs.2021.02.068. IF: 16.002, Q1, 26 citations.

Wojnowski, W., Kalinowska, K., Gębicki, J., Zabiegała, B., Monitoring the btx volatiles during 3d printing with acrylonitrile butadiene styrene (Abs) using electronic nose and proton transfer reaction mass spectrometry (2020) *Sensors*, 20 (19), 5531, DOI: 10.3390/s20195531. IF: 3.576, Q2, 6 citations.

Kalinowska, K., Lenartowicz, P., Namieśnik, J., Marć, M., Analytical procedures for short chain chlorinated paraffins determination - How to make them greener? (2019) *Science of the Total Environment*, 671, 309. DOI: 10.1016/j.scitotenv.2019.03.312. IF: 6.551, Q1, 8 citations.

Wojnowski, W., Kalinowska, K., Majchrzak, T., Płotka-Wasyłka, J., Namieśnik, J., Prediction of the biogenic amines index of poultry meat using an electronic nose (2019) *Sensors*, 19 (7), 1580, DOI: 10.3390/s19071580. IF: 3.275, Q2, 28 citations.

Wojnowski, W., Płotka-Wasyłka, J., Kalinowska, K., Majchrzak, T., Dymerski, T., Szweđa, P., Namieśnik, J., Direct determination of cadaverine in the volatile fraction of aerobically stored chicken breast samples (2018) *Monatshefte für Chemie*, 149 (9), 1521, DOI: 10.1007/s00706-018-2218-7. IF: 1.501, Q3, 2 citations.

ΣIF: 89.362, Σcitations: 111 (96 without self-citations) , h-index: 7 (Scopus)

### **Chapters and articles in non-JCR listed journals**

Wojnowski, W., and Kalinowska, K., Machine learning and electronic noses for medical diagnostics (2021) In: *Artificial Intelligence in Medicine*. DOI: 10.1007/978-3-030-58080-3\_329-1.

Majchrzak, T., Kalinowska, K., Lubinska-Szczygeł, M., Rózańska, A., Dymerski, T., Wardencki, W., Namieśnik, J., Recent Applications of 1D GC-MS and 2D GC-MS in Foodomics Studies (2020) In: *Comprehensive Foodomics*, 19, DOI: 10.1016/B978-0-08-100596-5.22773-X.

Płotka-Wasyłka, J., Fabjanowicz, M., Kalinowska, K., Namieśnik, J., Green chromatography: State-of-the-art, opportunities and future perspectives (2020) In: *RSC Green Chemistry*, (66) 255. DOI: 10.1039/9781788016148-00255.

Płotka-Wasyłka, J., Fabjanowicz, M., Kalinowska, K., Namieśnik, J. (2019) History and Milestones of Green Analytical Chemistry. In: *Green Analytical Chemistry. Green Chemistry and Sustainable Technology*. DOI: 10.1007/978-981-13-9105-7\_1.

Kalinowska K., Majchrzak T., Dymerski T., Namieśnik J., Nowe rozwiązania metodyczne w zakresie badań oddechu stosowane w diagnostyce medycznej (2018) *Analityka: Nauka i Praktyka*, 3.

Fabjanowicz M., Kalinowska K., Namieśnik J., Płotka - Wasylka J., Evaluation of green sample preparation techniques for organic compounds (2018) *Current Green Chemistry*, 5 168.

### **Conferences and scientific internships**

January – May 2019, University of Pau and the Adour Region, Institute of Analytical and Physical Chemistry for the Environment and Materials (IPREM), supervisor prof. J. Szpunar.

Fabjanowicz M., Różańska A., Kalinowska K., Płotka-Wasyłka J., Zminiaturyzowana metoda do oznaczania amin biogennych w próbkach wina opartej na mikroekstrakcji typu ciecz-ciecz wspomaganą efektem wysolenia w połączeniu z chromatografią gazową sprzężoną ze spektrometrią mas (2022) *XI Polska Konferencja Chemii Analitycznej*, Łódź, Poland.

Wojnowski W., Kalinowska K., Zabiegała B., Monitorowanie w czasie rzeczywistym emisji lotnych związków organicznych podczas drukowania techniką druku 3D z wykorzystaniem filamentów z polilaktydu (2021) *III Ogólnopolska Konferencja Naukowa Biopolimery – źródło nowych materiałów*, Lublin, Polska.

Kalinowska K., Tobiszewski M., Application of chromogenic dye in biogenic amines determination using spectrophotometry (2021) *17th International Students Conference “Modern Analytical Chemistry”*, Prague, Czech Republic.

Różańska A., Fabjanowicz M., Kalinowska K., Polkowska Ż., Płotka-Wasyłka J., The use of salting-out assisted liquid-liquid microextraction and gas chromatography-mass spectrometry for the determination of biogenic amines in fruit juices (2021) *XXI EuroFoodChem*, Belgrad, Serbia.

Kalinowska K., Strzemińska I., Factor C., Robert P., Szpunar J., Łobiński R., Optimization of fast size exclusion chromatography coupled to ICPMS for speciation of gadolinium in soft rat tissues (2019) *7th International Symposium on Metallomics*, Warszawa, Polska.

Kalinowska K., Płotka-Wasyłka J., Bezpośrednia analiza próbek z wykorzystaniem ultraszybkiej chromatografii gazowej. Klasyfikacja win (2018) *III Interdyscyplinarna Akademicka Konferencja Ochrony Środowiska*, Gdańsk, Polska.

Kalinowska K., Wojnowski W., Dymerski T., Namieśnik J., Evaluation of poultry meat shelf life using proton transfer reaction mass spectrometry (2017) *14th International Students Conference “Modern Analytical Chemistry”*, Prague, Czech Republic.





## Co-authors' statements of contribution

Oświadczenie autorów, dotyczące opisu udziału i wkładu procentowego udziału w przygotowaniu publikacji naukowej.

Autorzy pracy: Kaja Kalinowska, Marta Bystrzanowska, Marek Tobiszewski

Tytuł pracy: Chemometrics approaches to green analytical chemistry procedure development

Czasopismo, rok wydania, zeszyt, numery stron: Current Opinion in Green and Sustainable Chemistry, 2021, 100498.

Lp.	Autor	Opis udziału	Wkład procentowy udziału	Podpis
1	Kaja Kalinowska	Pomoc w przygotowaniu maszynopisu pracy. Prace związane z uzyskaniem zgody na udostępnienie rysunku. Przygotowanie rysunków: 1, 2, 3.	15	Kalinowska
2	Marta Bystrzanowska	Pomoc w przygotowaniu maszynopisu pracy. Formatowanie maszynopisu pracy zgodnie z wymaganiami czasopisma.	15	Bystrzanowska
3	Marek Tobiszewski	Stworzenie koncepcji pracy przeglądowej. Funkcja autora korespondencyjnego, przygotowanie odpowiedzi na recenzje. Przygotowanie maszynopisu pracy podrozdziały: streszczenie, 1., 2., 3., 4., wnioski.	70	Tobiszewski

Data: 23.04.21

Sporządził: Marta Bystrzanowska

Bystrzanowska

Oświadczenie autorów, dotyczące opisu udziału i wkładu procentowego udziału w przygotowaniu publikacji naukowej.

Autorzy pracy: Kaja Kalinowska, Wojciech Wojnowski, Marek Tobiszewski

Tytuł pracy: Smartphones as tools for equitable food quality assessment

Czasopismo, rok wydania, zeszyt, numery stron: Trends in Food Science & Technology , 2021

Lp.	Autor	Opis udziału	Wkład procentowy udziału	Podpis
1	Kaja Kalinowska	Opracowanie koncepcji artykułu, napisanie manuskryptu, edycja manuskryptu.	45%	<i>Kalinowska</i>
2	Wojciech Wojnowski	Napisanie manuskryptu, sporządzenie rysunków, korekta językowa, edycja manuskryptu.	45%	<i>W. Wojnowski</i>
3	Marek Tobiszewski	Określenie zakresu tematycznego, korespondencja z edytorem, napisanie manuskryptu, edycja manuskryptu.	10%	<i>Tobiszewski</i>

Data: 05.03.2021

Sporządziła: Kaja Kalinowska

**Oświadczenie autorów, dotyczące opisu udziału i wkładu procentowego udziału w przygotowaniu publikacji naukowej.**

**Autorzy pracy:** Kaja Kalinowska, Marek Tobiszewski

**Tytuł pracy:** Green, simple analytical method for total biogenic amines content determination in wine using spectrophotometry

**Czasopismo, rok wydania, zeszyt, numery stron:** Food Chemistry, 2023, 402, 134457;  
doi: 10.1016/j.foodchem.2022.134457

Lp.	Autor	Opis udziału	Wkład procentowy udziału	Podpis
1	Kaja Kalinowska	Opracowanie koncepcji, przeprowadzenie badań, napisanie manuskryptu pracy, kontakt z edytorem	90 %	<i>Kalinowska</i>
2	Marek Tobiszewski	Nadzorowanie pracy, korekta	10 %	<i>Tobiszewski</i>

Data: 18.10.2022

Sporządziła: Kaja Kalinowska

Oświadczenie autorów, dotyczące opisu udziału i wkładu procentowego udziału w przygotowaniu publikacji naukowej.

**Autorzy pracy:** Kaja Kalinowska, Wojciech Wojnowski, Marek Tobiszewski

**Tytuł pracy:** Simple analytical method for total biogenic amines content determination in wine using a smartphone

**Czasopismo, rok wydania, zeszyt, numery stron:** Analytical Methods (2023) 15 (11), 1395. DOI: 10.1039/d2ay02035a.

Lp.	Autor	Opis udziału	Wkład procentowy udziału	Podpis
1	Kaja Kalinowska	Opracowanie koncepcji artykułu, zaplanowanie badań, przeprowadzenie badań, walidacja, napisanie manuskryptu, edycja manuskryptu, korespondencja z edytorem.	70%	Kalinowska
2	Wojciech Wojnowski	Napisanie manuskryptu, zaplanowanie badań, sporządzenie rysunków, korekta językowa, edycja manuskryptu.	20%	Wojnowski
3	Marek Tobiszewski	Określenie zakresu tematycznego, nadzorowanie pracy, edycja manuskryptu.	10%	Tobiszewski

Data: 20.06.2023

Sporządziła: Kaja Kalinowska

**Oświadczenie autorów, dotyczące opisu udziału i wkładu procentowego udziału w przygotowaniu publikacji naukowej.**

**Autorzy pracy:** Kaja Kalinowska, Muhammad Saad Hussain, Marek Tobiszewski

**Tytuł pracy:** Simple smartphone-based methods for the determination of bioactive compounds in wine

**Czasopismo, rok wydania, zeszyt, numery stron:** nieopublikowane

Lp.	Autor	Opis udziału	Wkład procentowy udziału	Podpis
1	Kaja Kalinowska	Opracowanie koncepcji artykułu, zaplanowanie badań, przeprowadzenie badań, walidacja, sporządzenie rysunków, napisanie manuskryptu, edycja manuskryptu, korespondencja z edytorem.	60%	<i>Kalinowska</i>
2	Muhammad Saad Hussain	Napisanie manuskryptu, przeprowadzenie badań, walidacja, analiza danych, sporządzenie rysunków.	30%	<i>Sh</i>
3	Marek Tobiszewski	Określenie zakresu tematycznego, nadzorowanie pracy, edycja manuskryptu.	10%	<i>Tobiszewski</i>

Data: 20.06.2023

Sporządziła: Kaja Kalinowska