



DISTORSIONAL ANALYSIS OF I-SECTION BEAM

MARCIN KUJAWA

*Department of Structural Mechanics and Bridges,
Faculty of Civil and Environmental Engineering,
Gdansk University of Technology,
Narutowicza 11/12, 80-233 Gdansk, Poland
markuj@pg.gda.pl*

(Received 16 March 2012)

Abstract: An elastic stiffness matrix was derived in the case of distortion of a restrained thin-walled I-section beam using the minimum total stationary elastic energy condition (Przemieniecki J S 1968 *Theory of Matrix Structural Analysis*, McGraw-Hill, NY). The function describing the angle of distortion was adopted from the solution of differential equation in the case of restrained distortion. The example presented in the paper helps to assess the correctness of the proposed solution. The proposed elastic stiffness matrix is applicable for solving distortion problems of bar structures composed of thin-walled members.

Keywords: distortion, thin-walled I-section beam, elastic stiffness matrix, energetic approach, Castigliano's method

1. Introduction

The most common elements in engineering structures are bars which are generally defined as having one dimension (length) significantly large in comparison with other, *i.e.* cross-sectional dimensions. One of the basic assumptions of any theory of bars and bar systems is the assumption of invariance (non-deformability) of the cross-section which is repeated in theories of bending and torsional strength as well as in the related theories of stability and dynamics. The state of deformation is usually described with four independent quantities, namely the three components of displacement and the angle of rotation (twisting) of the cross-section.

This assumption is satisfactory when applied to full-or thick-walled bars, while accepting it in the case of thin-walled bars can lead to serious inaccuracies. This arises from the fact that not all cross-sectional dimensions are comparable: the wall thickness is in fact very small compared to the rest of its dimensions. As a result, this creates additional strains that develop primarily in the direction of



the least resistance, *i.e.*, distortions of the thin wall cross-section in the plane of section.

It may be presumed that the phenomenon is sufficiently well known, both from a theoretical and practical point of view, in examining the stability of various important types of thin-walled bars of open and closed sections. However, so far, not enough attention has been paid to the static analysis of thin-walled structures with additional degrees of freedom resulting from the deformation of the bar in the plane of cross-section. The warp effect has already been widely taken into account, as the seventh degree of freedom [1–3], but as yet, the deformation in the plane of cross-section has usually been ignored. However, the distortion is a phenomenon which takes place at torsion of thin-walled bar systems and one should not forget about it during the analysis. Such a special type of deformation of the cross-section, quite important in the engineering practice, is discussed in this paper.

2. Distortional elastic stiffness matrix

Let us consider an element *ik* cut from a thin-walled I-beam. The element has length *l*, constant cross-section *A* and is made of a homogeneous material with Young's module *E* and Poisson's ratio ν . The resistance of distortion of I-section members is due principally to the torsional rigidity of the flanges, and to the flexural rigidity of the web which is bent in single curvature. It was assumed that the deformation of flanges in the plane of the cross-section was negligible compared to the deformation of the web. The cross-sectional deformation, resulting from the above assumptions is shown in Figure 1.

For the element *ik* let us define the function of the distortion angle from the differential equation [4]:

$$GJ_{df} \frac{d^2\psi}{dx^2} + D_w \left(\frac{\partial^2 w}{\partial z^2} + \nu \frac{\partial^2 w}{\partial x^2} \right) = 0 \quad (1)$$

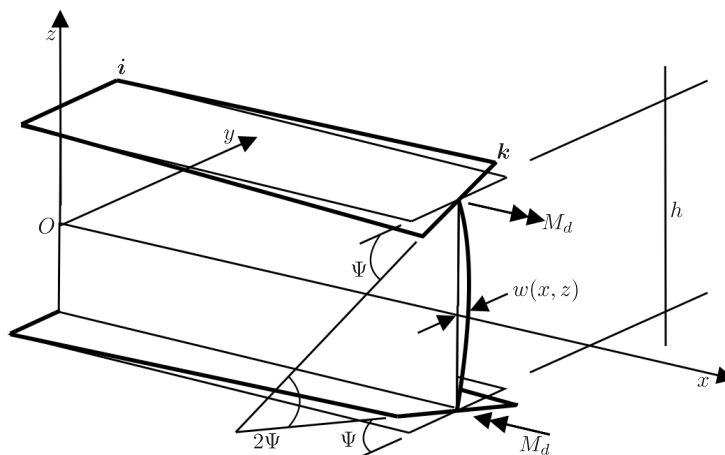

Figure 1. Distortion of member

An approximate solution of (1) can be obtained by assuming that the web deflection is given by:

$$w(x, z) = \frac{h\psi}{4} \left(1 - \frac{4z^2}{h^2}\right) \quad (2)$$

In this case Equation (1) reduces to:

$$\frac{d^2\psi}{dx^2} - \kappa_\psi^2 \psi = 0 \quad (3)$$

where $\kappa_\psi = \sqrt{2D_w/hGJ_{df}}$ is a characteristic number which depends on the ratio of the pure torsional rigidity of one flange GJ_{df} , understood in the sense of Saint-Venant's theory, and $D_w = \frac{Et^3}{12(1-\nu^2)}$ is the bending stiffness of the web in which t is the thickness of the beam web. The general solution of Equation (3) is:

$$\psi(x) = \bar{C}_1 e^{\kappa_\psi x} + \bar{C}_2 e^{-\kappa_\psi x} \quad (4)$$

Transforming function (4) from exponential to hyperbolic and adopting the new variables, C_1 and C_2 , instead of $(\bar{C}_1 + \bar{C}_2)$, $(\bar{C}_1 - \bar{C}_2)$, we obtain the final form of the equation of the angle of distortion:

$$\psi(x) = C_1 \cosh(\kappa_\psi x) + C_2 \sinh(\kappa_\psi x) \quad (5)$$

Substituting the boundary conditions of the form:

$$\begin{aligned} \psi &= \psi_i, \text{ for } x = 0 \\ \psi &= \psi_k, \text{ for } x = l \end{aligned}$$

we set the constants C_1 , C_2 and obtain:

$$\psi(x) = \sinh(\kappa_\psi x) [\psi_k \kappa_\psi \operatorname{csch}(\kappa_\psi l) - \psi_i \coth(\kappa_\psi l)] + \psi_i \cosh(\kappa_\psi x) \quad (6)$$

Let us write the equation of the angle of distortion beam (6) in a matrix form:

$$\psi(x) = \Psi^T \mathbf{C} \mathbf{q} \quad (7)$$

where Ψ and \mathbf{q} are vectors of the form:

$$\begin{aligned} \Psi^T &= \{ \cosh(\kappa_\psi x), \sinh(\kappa_\psi x) \} \\ \mathbf{q}^T &= \{ \psi_i, \psi_k \} \end{aligned}$$

and \mathbf{C} is a matrix of elements dependent on the characteristic number κ_ψ and the length of the beam l .

The elastic energy is given by [5]:

$$U = \frac{1}{2} \left\{ \int_0^l \left[\frac{1}{2} G J_{df} (\psi')^2 + \frac{D_w}{h} \psi^2 \right] dx \right\} \quad (8)$$

Substituting the previously derived equation of the angle of distortion in the matrix form (7) into relation (8) we obtain:

$$\frac{1}{2} \left\{ \mathbf{q}^T \int_0^l \left[\frac{1}{2} G J_{df} (\mathbf{C}^T \Psi') (\Psi')^T \mathbf{C} + \frac{D_w}{h} (\mathbf{C}^T \Psi) (\Psi)^T \mathbf{C} \right] dx \mathbf{q} \right\} = \frac{1}{2} \mathbf{q}^T \mathbf{k}_{L\Psi} \mathbf{q} \quad (9)$$

where $\mathbf{k}_{L\Psi}$ is the unknown elastic stiffness matrix.

It is known from Castigliano's theorem that the derivative of a linear function of the elastic energy of the nodal displacement vector \mathbf{q} corresponds to the vector of nodal forces $\mathbf{f}^T = \{M_{d_i}, M_{d_k}\}$ (Figure 1):

$$\frac{\partial}{\partial \mathbf{q}} \left(\frac{1}{2} \mathbf{q}^T \mathbf{k}_{L\Psi} \mathbf{q} - \mathbf{f}^T \mathbf{q} \right) = 0 \rightarrow \mathbf{k}_{L\Psi} \mathbf{q} = \mathbf{f} \quad (10)$$

where M_{d_i}, M_{d_k} denote the distortional moments at the ik nodes. Equation (10) determines the total potential energy of the system where $\mathbf{f}^T \mathbf{q}$ is the potential energy of external forces, and the first part of the formula is the energy of elastic internal forces. By implementing the operations to set the individual components of the stiffness matrix arising from the relation (9), we find the elastic stiffness matrix in the distortion form:

$$\mathbf{k}_{L\Psi} = \begin{bmatrix} [k_{L\Psi,11}] & [k_{L\Psi,12}] \\ \text{sym.} & [k_{L\Psi,22}] \end{bmatrix} \quad (11)$$

related to the internal forces according to the relation:

$$\begin{Bmatrix} M_{d_i} \\ M_{d_k} \end{Bmatrix} = \begin{bmatrix} [k_{L\Psi,11}] & [k_{L\Psi,12}] \\ \text{sym.} & [k_{L\Psi,22}] \end{bmatrix} \begin{Bmatrix} \psi_i \\ \psi_k \end{Bmatrix} \quad (12)$$

where:

$$[k_{L\Psi,11}] = \frac{D_w \coth(\kappa_\psi l)}{h \kappa_\psi} \quad [k_{L\Psi,12}] = -\frac{D_w \operatorname{csch}(\kappa_\psi l)}{h \kappa_\psi} \quad [k_{L\Psi,22}] = \frac{D_w \coth(\kappa_\psi l)}{h \kappa_\psi}.$$

Thus, the distortional stiffness can be expressed as:

$$\frac{M_d}{\psi} = \frac{D_w \coth(\kappa_\psi l)}{h \kappa_\psi} = \frac{1}{2} G J_{df} \kappa_\psi \coth(\kappa_\psi l) \quad (13)$$

The proposed solution (12)–(13) corresponds to the theory proposed by Vacharajittiphan and Trahair [4] and it can be approximated by:

$$\frac{M_d}{\psi} = \frac{D_w}{h \kappa_\psi} = \frac{1}{2} \sqrt{\frac{2 D_w G J_{df}}{h}} \quad (14)$$

with an error of less than 10%, while $\kappa_\psi l > 1.5$ (Table 1). This approximation was also used by Tong *et al.* [5].

3. Analysis of convergence – numerical example

Let us consider the I-section cantilever ($E = 70$ GPa, $\nu = 0.3$) which was loaded by two equal and opposite distortion moments on the free end of a value of $M_d = 50$ Nm (Figure 2). These moments caused the web to deflect and the flanges to rotate (Figure 1). The comparison for the rotation ψ along one of the flanges was done by the finite element method using 6144 fully integrated finite-strain square (6 dof and 4 nodes) shell elements for general-purpose stress/displacement analysis and the proposed theoretical approximation using 10 and 100 beam finite elements (12) shown in Figure 3. The commercial computational package MATLAB [6] was used in the study.

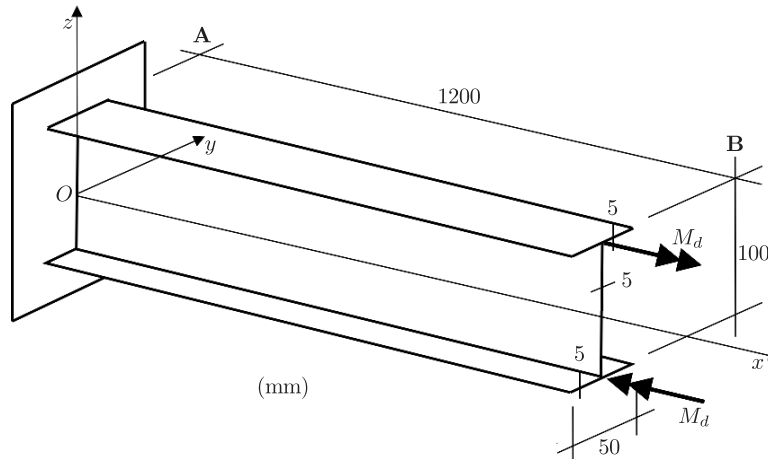

Figure 2. Geometrical data for distortion analysis

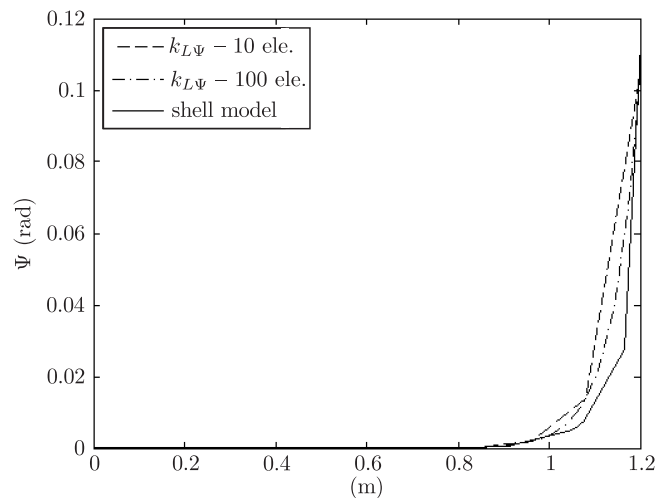

Figure 3. Comparison of solutions for distortional angle along one of the flanges

Table 1. Comparison of solutions for distortional stiffness

$\frac{M_d}{\psi}$ (difference %)	
Method	L [m]
shell model	1.2
proposed theory (13)	442.1
approximated solution (14)	473.9 (7.19%)
	474.1 (7.24%)

The solutions for the distortional stiffness, $\frac{M_d}{\psi}$, of the beam shown in Figure 2 are compared in Table 1. The results of analytical solutions were compared to the finite element method – shell model. The difference did not exceed 10%.



The differences between solutions result from the adopted approximations (2).

4. Summary

The effect of the distortional deformation described in the paper is particularly important in the analysis of bars and spatial bar structures subjected to torsion. The distortion of one member in the node is restrained by the resistance of another member to warping [4]. It is recommended that the stiffness matrix of thin-walled bars should be extended not only with the cross-section warping but its distortion as well. It should be remembered that the proposed theory is an approximate solution due to the adopted web deflection function (2). Nevertheless, the proposed theory coincides very well with the numerical solution for the shell model. Moreover, it should be noted that the angle of the distortion deformation does not extend to the entire length of the bar, but only to 3 times the value of h , where h is the I bar cross-section height (Figure 1). Hence, for bars or elements more than 3 of the section in length, the meshgrid should be concentrated. The correct solution was obtained when the bar was divided into 10 finite elements (Figure 3).

References

- [1] Barsoum R S and Gallagher R H 1970 *Int. J. Num. Meth. in Engng* **2** (3) 335
- [2] Kreja I, Kujawa M, Mikulski T and Szymczak C 2003 *Sensitivity Analysis of Beams and Frames Made of Thin-walled Members*, Gdansk University of Technology Publishing Houses, Gdansk
- [3] Kujawa M 2009 *Static and Sensitivity Analysis of Grids Made of Thin-walled Members*, Gdansk University of Technology Publishing House, Gdansk, **97** (in Polish)
- [4] Vacharajittiphan P and Trahair N S 1974 *J. Structural Division* **100** (3) 547
- [5] Tong G S, Yan X X and Zhang L 2005 *J. Constructional Steel Research* **61** (6) 749
- [6] Kwon Y W and Bang H 2000 *The Finite Element Method Using MATLAB*, CRC Press, New York (2nd edition)

