

Exhaust gas temperature measurements in diagnostic examination of naval gas turbine engines

Part II Unsteady processes

Zbigniew Korczewski, Assoc. Prof.
Gdansk University of Technology



The second part of the article presents the results of operating diagnostic tests of a two- and three-shaft engine with a separate power turbine during the start-up and acceleration of the rotor units. Attention was paid to key importance of the correctness of operation of the automatic engine load control system, the input for which, among other signals, is the rate of increase of the exhaust gas flow temperature. The article presents sample damages of the engine flow section which resulted from disturbed functioning of this system. The unsteady operation of the compressor during engine acceleration was the source of excessive increase of the exhaust gas temperature behind the combustion chamber and partial burning of the turbine blade tips.

ABSTRACT

Key words: technical diagnostics; naval turbine engines; exhaust gas temperature; unsteady processes; unstable compressor operation; partial blade tip burning

INTRODUCTION

In unsteady states of turbine engine operation, when it changes from one steady-load state to the other, operating parameters and power indices of the thermal and flow processes taking place inside the engine, as well as the processes themselves change in time. This happens, for instance, when the engine is started up or shut down, during engine acceleration¹⁾ or deceleration²⁾, as well as during changes of direction of rotation of the driving turbine rotor – in reversal engines.

The behaviour of the naval turbine engines in unsteady states makes their users perform specific actions to secure long-lasting and faultless engine operation. On the one hand, the user should know what course the transient processes take, how the operating parameters change, where and when the overload phenomena take place and what is their nature and time of duration. On the other hand, the opportunities for performing necessary experimental tests of engines in marine conditions are strictly limited by numerous structural and operational restrictions.

The operating practice of naval engines reveals that the realisation of transient processes in extremely unfavourable conditions may result in exceeding the exhaust gas temperature limits and unstable operation of the compressor and the

combustion chamber, which may finally lead to partial burning of turbine blade tips [1, 2, 6, 9]. This refers in particular to the engine start-up and acceleration processes.

ENGINE START-UP AND ACCELERATION

The start-up of the naval turbine engine is an unsteady process oriented on bringing the rotor units from the state of rest to the idling rotational speed. It is mainly characterised by the fact that the largest changes of energy conversion processes are recorded during its realisation. In as little as a few seconds the structural components of the flow section are subject to strong thermal loads, with the instantaneous temperature of the inflowing exhaust gas increasing by $\Delta T = 60 - 70$ K/s, Fig. 1. This excessive increase of the exhaust gas temperature may be provoked by the worsened technical state of the flow section, or result from faulty operation of the automatic engine load control system which controls the rates of fuel and supply air [4, 5, 7, 11].

Fig. 2 shows sample time-histories of the exhaust gas temperature behind the low pressure turbine and behind the exhaust gas generator as the functions of the start-up process time duration. These time-histories were recorded during five years of operation of a three-shift engine with a separate

¹⁾ acceleration - process of increasing the rotational speed of the rotor units.

²⁾ deceleration - process of decreasing the rotational speed of the rotor units.

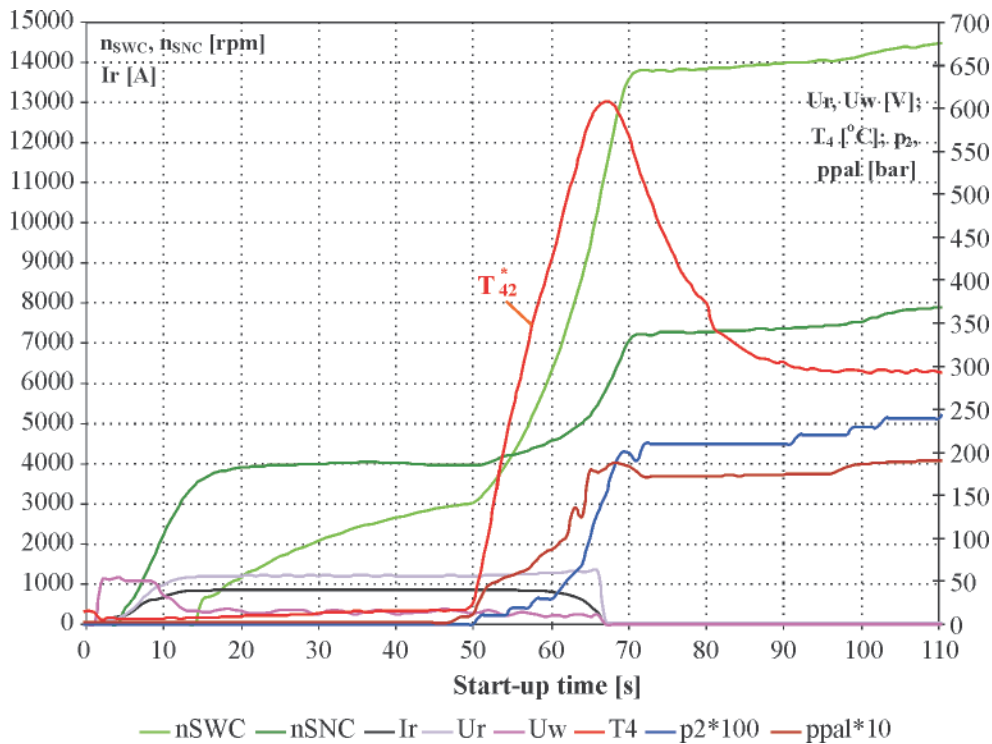

Fig. 1. Time-histories of parameters controlling the start-up process of the three-shaft engine with a separate power turbine n_{SNC} , n_{SWC} – rotational speed of, respectively, the low pressure and high pressure compressor; I_r , U_r , U_w – current parameters of the electric starter: strength and voltage of the starting current, and the field voltage; T_4 – averaged temperature of the exhaust gas flow behind the exhaust gas generator; p_2 – air pressure behind the high pressure compressor, $ppal$ – fuel pressure in front of the injectors

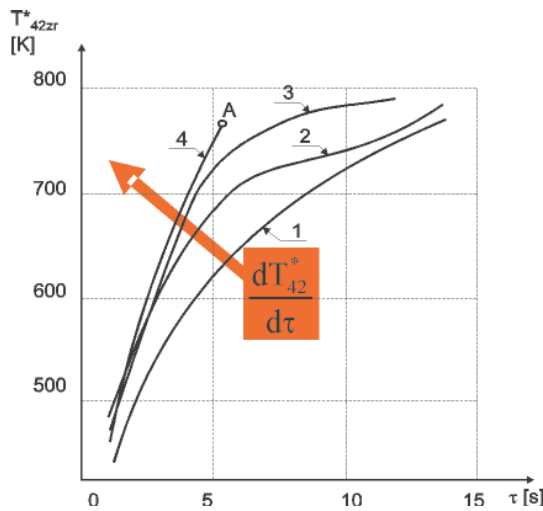

Fig. 2. Exhaust gas temperature changes recorded behind TNC of a three-shaft engine with a separate power turbine vs. start-up time: 1 – brand-new engine; 2 – engine in third year of operation; 3 – engine after five years of operation; 4 – unsuccessful engine start-up after five years of operation; A – automatic engine shut-down

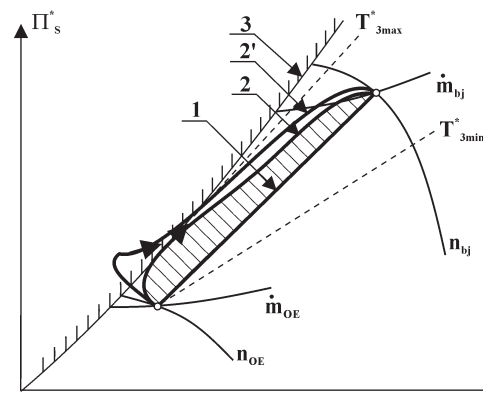

Fig. 3. Changes of range of cooperation between compressor, combustion chamber, and turbine during engine start-up: 1 – cooperation line in steady-load states; 2 – change of operating range at $dT^*/d\tau = dop$; 2' – change of operating range at $dT^*/d\tau = kryt$; 3 – stable operation limit; $n_{bj} > n_{OE}$ – isodromes of idling and electric rotation of the compressor-turbine unit, $\dot{m}_{bj} > \dot{m}_{OE}$ – lines of constant fuel charge for idling and electric rotation (beginning of combustion); T^*_{3max} , T^*_{3min} – isotherms of the exhaust gas flow leaving the combustion chamber

power turbine on a ship. A characteristic trend is observed for continuous increase of the exhaust gas temperature derivative when the engine's operational time increases.

The curves shown in the figure reveal that the increased worsening of the technical state of the engine flow section (confirmed by systematic endoscopic examinations [9]) has finally led to the increase of the exhaust gas temperature to the limit at which the automatic control system stopped the start-up process, thus protecting the engine against the damage (point A on curve 4).

An additional threat for the reliability of the started-up engine is possible excessive deflection of the cooperation line on the compressor characteristic from the optimal line and entering the zone of unstable operation (so-called compressor stall) [3, 8, 12]. The graphical interpretation of the both undesired

phenomena is given in Fig. 3 which shows the combined characteristics of the compressor-combustion chamber-turbine system, with projected hypothetical curves of system cooperation during the engine start-up process.

The fuel ignition and the increasing exhaust gas temperature shift the points of system cooperation from the optimal line for steady-state conditions towards the stable operation limit, which is illustrated by lines 2 and 2' in Fig. 3. The margin of stable operation of the compressor, defined as:

$$\Delta Z_s = (Z_s - 1)100\% \quad (1)$$

where:

$$Z_s = \frac{(\pi_s / \dot{m})_{gr}}{(\pi_s / \dot{m})_p} \quad (2)$$

Z_s – stable compressor operation margin coefficient;

$(\pi_s/\dot{m})_{gr}$ – ratio of the compressor's compression to the mass flow rate of the working medium at the stable operation limit;

$(\pi_s/\dot{m})_p$ – ratio of the compressor's compression to the mass flow rate of the working medium when the engine switches from the stable speed of electric rotation to the stable speed of idling, is reduced.

Reducing the stable operation margin of the turbine engine compressor below 5% results in boundary layer separation on convex surfaces of the rotor blades and pulsations of the forced air flow [3, 8, 10].

Similar gasodynamic phenomena take place in the process of acceleration of the engine rotor units when the engine shifts from one stable-load state to the other. It results from the equation of motion of each rotor unit that the acceleration time τ_p depends on the mass polar moment of inertia J of its rotating system and the range of rotational speed changes from n_1 to n_2 , according to formula [3]:

$$\tau_p = \frac{\pi}{30} J \int_{n_1}^{n_2} \frac{dn}{M_p} \quad (3)$$

Increasing the values of the accelerating torque M_p of the engine shaft, and/or reducing the values of the mass polar moment of inertia of the rotating masses and the rotational speed range shorten the time needed for changing the operating engine parameters to the required higher-load regime. Therefore to increase the engine power, the rate of the fuel supplied to the engine combustion chamber for each intermediate rotational speed of the rotor unit should be larger than in case of engine operation in steady-load conditions at the same rotational speed.

The extremely intensive course of the engine fuel supply process during the acceleration $\dot{m}_{pal} = f(n)$ is limited by the maximal permissible exhaust gas temperature measured at high-pressure turbine inlet, due to the creep-resistance of constructional materials of the turbine blades, the efficiency of operation of the turbine cooling system, and the limit of stable operation of the compressor. The maximal permissible excess fuel charge determines the minimal time of engine acceleration.

The reserve of stable gasodynamic operation of the compressor ΔZ_{sa} which is used in the acceleration process is calculated for each instantaneous engine rotational speed as the product of two coefficients: ΔZ_{su} – the reserve of compressor stability determined by the exhaust gas temperature at turbine inlet when the engine operates in steady-load conditions, and ΔZ_{sp} – the reserve of compressor stability which characterises permissible exceeding of the exhaust gas temperature at turbine inlet during acceleration:

$$\Delta Z_{sa} = \Delta Z_{sp} \cdot \Delta Z_{su} = \sqrt{\frac{T_{spala}^*}{T_{spalmax}^*} \cdot \frac{T_{spalmax}^*}{T_{spalu}^*}} = \sqrt{\frac{T_{spala}^*}{T_{spalu}^*}} \quad (4)$$

where:

$T_{spalmax}^*$ – exhaust gas temperature at turbine inlet in the maximal steady-load regime,

T_{spala}^* – maximal exhaust gas temperature at turbine inlet during the acceleration process,

T_{spalu}^* – exhaust gas temperature at turbine inlet in the steady-load regime.

In order to protect the engine against damages in these situations, the procedure of its use includes numerous limits which are automatically controlled by the start-up and load change process control system. The role of this system is to act on the rate of the energy delivered to the engine (as a result of

burning the fuel supplied from the fuel installation and from the electric starter) and control the flow duct geometry, including the adjustable inlet stator, air bleeding valves behind SWC, supply air valves for the second injector channel, reversal mechanism of the separate power turbine, etc., in order to protect the engine against excessive thermal and mechanical overloads of its constructional components. In Fig 3 this range is represented by the hatched area between lines 1 and 2. The block diagram of the system is shown in Fig. 4.

Fig. 4. Block diagram of the turbine engine exhaust gas temperature limit control system: A – impulse temperature control module, B – module of actuating mechanisms, C – naval turbine engine (OTSS), T – module

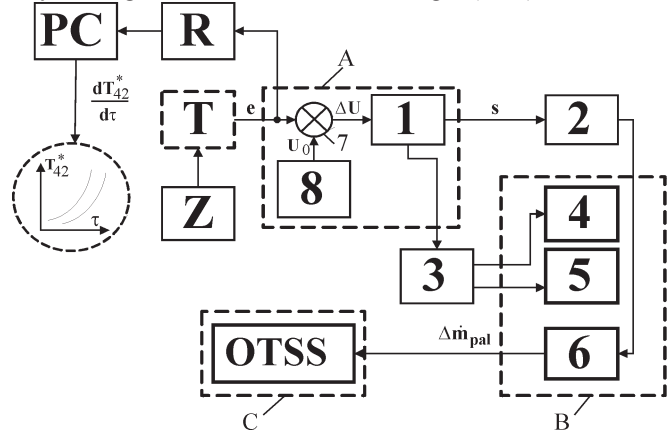

of thermo-couples (TXA-1368), Z – temperature setter, R – computer programme for measuring, recording and analysing engine start-up parameters, 1 – signal amplifier and modulator, 2 – electromagnetic control valve (by-pass) control circuit, 3 – main valve and emergency fuel drainage valve control circuit, 4 – main fuel valve (ZGP), 5 – emergency fuel valve (ZAP), 6 – fuel overflow valve (ZPP), 7 – comparing element, 8 – reference voltage generator, e – averaged thermoelectric voltage value, s – pulse control signal

The input signal for the system is the average exhaust gas temperature measured behind the exhaust gas generator. Excessive increase of this temperature can “only” provoke the action of the fuel overflow valve, or, in more severe situations, rapidly shut the engine down by acting simultaneously on the main valve and the emergency fuel drainage valve. It is noteworthy that the measurement of the exhaust gas temperature in the start-up process (and other unsteady processes) is burdened with some relatively large inertia which can be corrected electronically in the engine control system – Fig. 5 [13, 14]. Correction of the measuring inertia

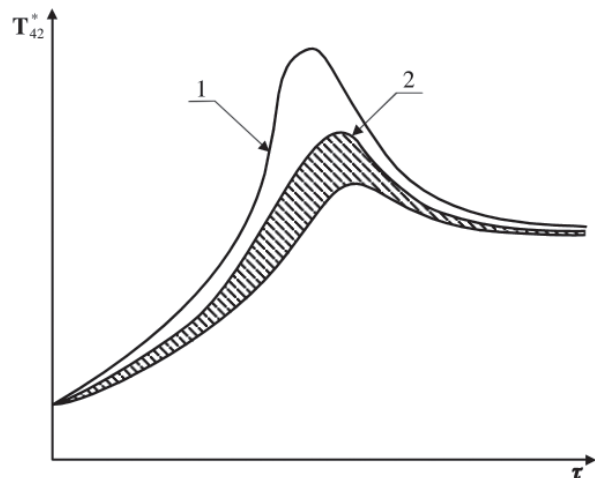

Fig. 5. Hypothetical time-histories of exhaust gas temperature changes during turbine engine start-up (acceleration) – the hatched area represents the range of correction of the measuring thermocouple inertia: 1 – real temperature, 2 – measured temperature

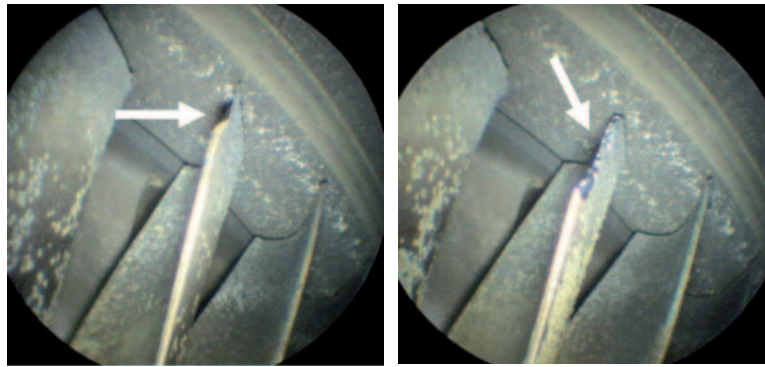

Fig. 6. Partly burned high-pressure turbine rotor blade tips

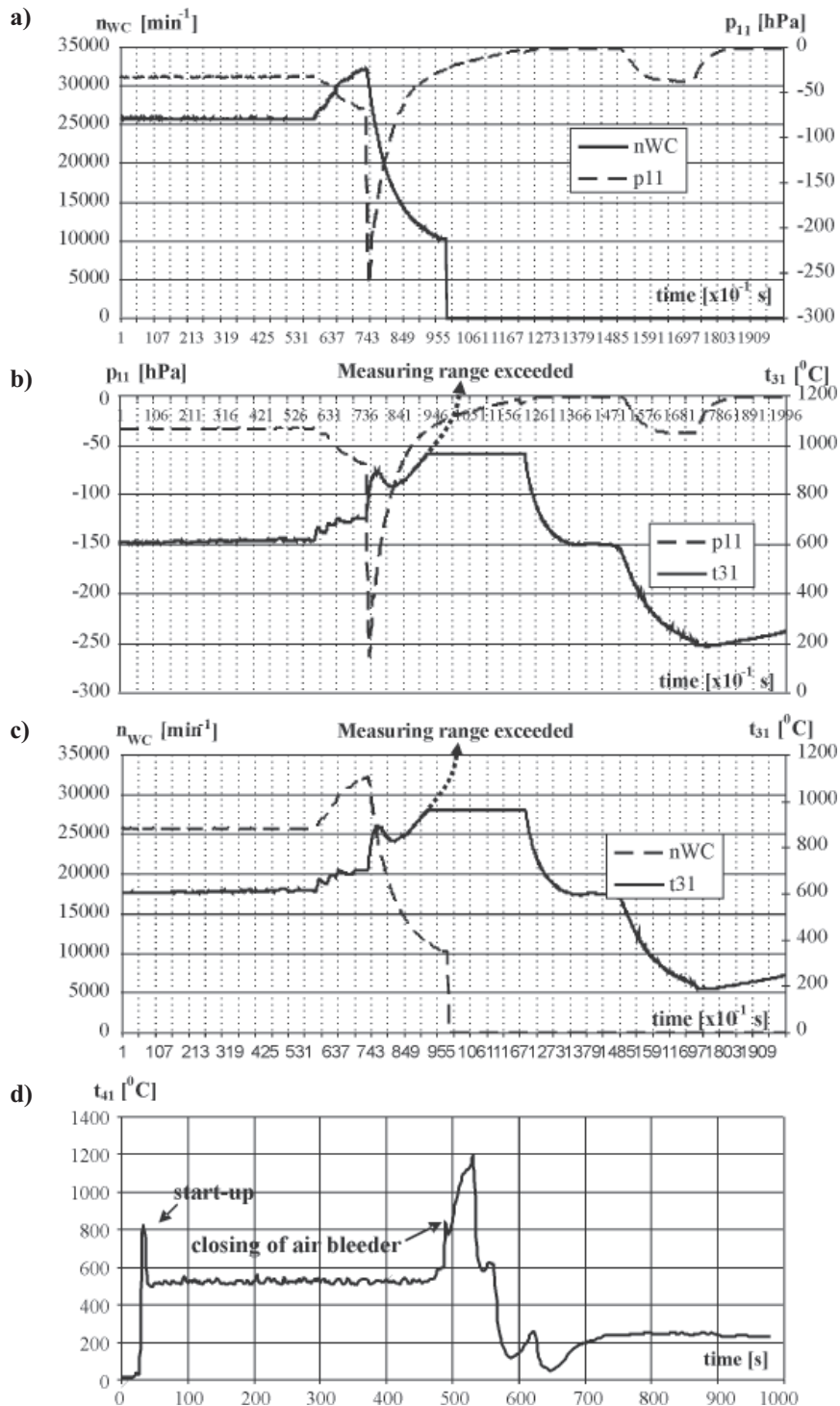

Fig. 7. Time-histories of high-pressure rotor rotational speed, negative pressure at compressor inlet, and exhaust gas temperatures at high-pressure turbine and separate power turbine inlets during the two-shaft engine acceleration process

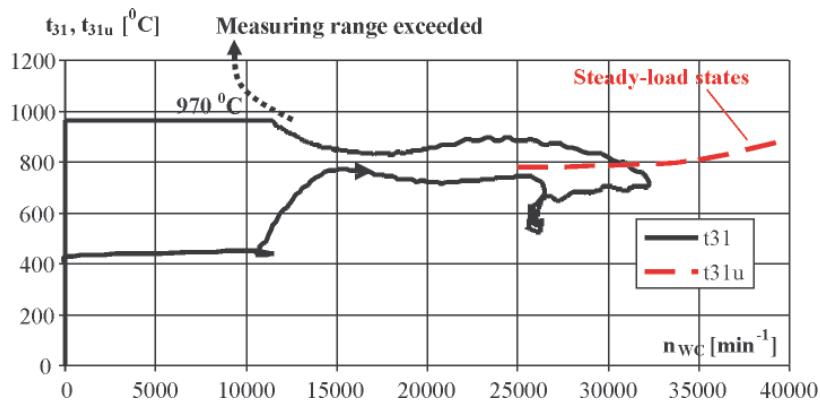

Fig. 8. Changes of exhaust gas temperature at high-pressure turbine inlet during start-up, acceleration, and steady-load engine operation of the two-shaft engine with a separate power turbine vs. high-pressure rotor rotational speed

of the thermocouples, which is done individually for each engine due to unrepeatability of the process of engine manufacturing, may reach as much as a few percent. This correction determines a so-called starting thermal sensitivity of the engine. On the other hand, interfering into producer's settings of the automatic control system during all time of engine operational use is not allowed, in particular in situations when the engine start-up becomes relatively difficult due to the worsened technical state of the flow section or the fuel supply system [13].

The absence or disturbed functioning of the automatic exhaust gas temperature limiter usually leads to huge and irreversible damages of the flow section, after which recovering the technical state of the engine is only possible via emergency repair done by the producer. Fig. 6 shows partly burned blade tips of the high-pressure turbine rotor, being the result of unstable operation of the combustion chamber during the acceleration process of a two-shaft engine with a separate power turbine.

After accidental choking of the air inlet duct and closing of the air bleeder valve, the increased rotational speed of the exhaust gas generator rotor was accompanied by rapid increase of the negative pressure in the compressor's inlet section, the decrease of the compressor output and, as a further consequence, by the increase of the exhaust gas temperature behind the combustion chamber – Fig. 7. The maximal permissible value of the exhaust gas temperature in steady-load states, limited to 970°C, was considerably exceeded, as shown in Figs. 7b,c and 8 (exceeding of the upper limit of the measuring range). Another parameter which was considerably exceeded in this case was the exhaust gas temperature at the separate power turbine – Fig. 7d.

In unsteady processes some short-lived exceeding of the maximum exhaust gas temperature at high-pressure turbine inlet is permissible, but this temperature is definitely not allowed to increase by over 20% of its maximal value referring to the nominal steady-load engine operation (depending on the used constructional materials and applied method of turbine cooling) [3, 6].

The excess rate of the fuel burned in the combustion chamber has led to excessive enrichment of the fuel-air mixture and the decrease of the excess air number λ – Fig. 9. When the critical level was reached ($\lambda \ll \lambda_{\min}$) at a given rotational speed of the exhaust gas generator rotor unit, the phenomenon of so-called „rich” flameout of the combustion chamber (flame breakdown) took place, with further automatic shutting the engine down. But despite this shut-down, the temperature of the flow section components (high pressure turbine blades) was so high that the resultant damages (partial burning, cracks) of the constructional material have eliminated the engine from further operation.

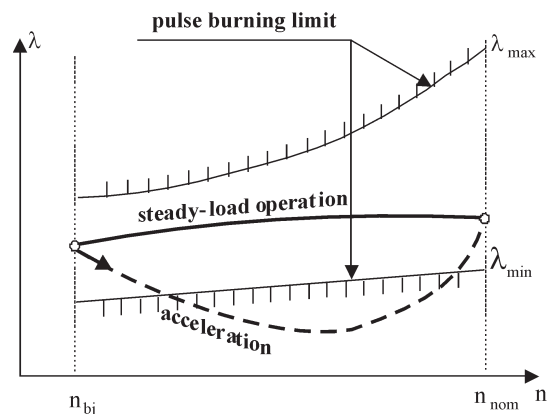

Fig. 9. Relation between the excess air number in the combustion chamber and the rotational speed of the exhaust gas generator rotor unit

CONCLUSIONS

- The rate of increase of the exhaust gas temperature during the turbine engine start-up and acceleration processes is decisive about engine reliability and lifetime. It is also a basic diagnostic parameter monitored in unsteady processes in order to assess the technical state of the flow section, the fuel and air supply system, and the automatic load control system.
- A key operational problem is adjusting the engine in a way which will simultaneously secure sufficient dynamics of the realised unsteady thermal and flow processes and, on the other hand, protect the engine against exceeding the limits of the exhaust gas temperature and the rate of its increase as possible threats of vast and irreversible damages of the engine flow section.
- Therefore one of basic requirements for the thermal protection system of the engine is maximal reliability of its work during engine operation, which is checked in systematic diagnostic tests.

BIBLIOGRAPHY

1. Balicki W., Szczeciński S.: *Diagnosing aeronautic turbine engines. Fluid-flow machines* (in Polish). Scientific Library of the Institute of Aviation. Warsaw 2001.
2. Boliński B., Stelmaszczyk Z.: *Aeronautic propulsion systems. Operation of turbine engines* (in Polish). WKiŁ, Warsaw 1981.
3. Cohen H., Rogers G.F.C., Saravanamuttur H.I.H.: *Gas turbine theory*. Longman Scientific & Technical, New York 1987.
4. Dzida M.: *Influence of gas turbine controller adjustment on ship propulsion system behavior in rough sea conditions Part 2. The simulation investigations*. Polish Maritime Research, No 1(39), 2004, Vol.11.

5. Dzida M.: *Simulation of ship propulsion gas turbine dynamics - an educational laboratory model*. Polish Maritime Research, No 4(22), 1999, Vol.6.
6. Hardin J.R. and others: *A gas turbine condition - monitoring system*. Naval Engineers Journal, November, USA 1995.
7. Korczewski Z.: *Method of diagnosing the flow section of a naval turbine engine in operation*. AMW (Ph.D. thesis – in Polish), Gdynia 1992.
8. Korczewski Z.: *Identifying gasodynamic processes in the compressor system of a naval turbine engine for diagnostic purposes* (in Polish) AMW Gdynia 1999.
9. Korczewski Z.: *Endoscopy of marine engines* (in Polish). AMW Gdynia 2008.
10. Orkisz M.: *Selected issues of jet turbine engine theory* (in Polish). ITE, Radom 1995.
11. Pawlak W., Wiklik K., Morawski J.M.: *Synthesis and tests of control systems of aeronautic turbine engines making use of computer simulation methods* (in Polish). Institute of Aviation, Warsaw 1996.
12. Szczeciński S.: *Aeronautic turbine engines* (in Polish). Wydawnictwo MON, Warsaw 1965.
13. *Technical and operating documentation of marine turbine engines GTU6a, DE59, ZORYA of UGT type, General Electric LM2500*.
14. *Reports on diagnostic tests of piston and turbine engines in operation on Polish Navy vessels* (in Polish) – AMW Research Works, Gdynia 1992 ÷ 2008.

CONTACT WITH THE AUTHOR
 Zbigniew Korczewski, Assoc. Prof.
 Faculty of Ocean Engineering
 and Ship Technology
 Gdansk University of Technology
 Narutowicza 11/12
 80-233 Gdansk, POLAND
 e-mail: z.korczewski@gmail.com