



EXHAUST TEMPERATURE MEASUREMENTS OF THE MARINE TURBOCHARGED DIESEL ENGINES IN OPERATION

Zbigniew Korczewski

*Gdansk University of Technology, Poland
Faculty of Ocean Engineering and Ship Technology
Department of Marine and Land Power Plants
11/12 Narutowicza Str. 80–233 Gdańsk, tel/fax: (58) 347 21 81,
e-mail: z.korczewski@gmail.com*

Abstract

The article presents the selected metrology issues concerning the exhaust temperature of the turbocharged marine engines during operation. The special concern has been paid on existing disturbances as well as thermodynamical interpretation of the recorded measurement signal. A diagnostic informativeness of the standard exhaust temperature's measurements has worked out while the engine runs in steady states has been also considered about many aspects of technical state evaluation of its working spaces, the fuel injection unit as well as the load exchange system.

Key words: *marine diesel engines, exhaust temperature, standard measurements.*

1. INTRODUCTION

The marine diesel engine exhaust temperature measured in characteristic control sections of its thermal-flow unit might stand for a valuable source of diagnostic information about a technical state of the elements separating that way the restrictive working spaces and also its fuel fed system (a fuel injection unit) as well as its load exchange system (a timing gear). In standard measurement units of the marine engines that are equipped with pulsatory turbocharging system the exhaust temperature is measured in the outlets of individual cylinders as well as in front and behind a turbine of the turbocompressor applying to this aim the traditional thermocouples of considerable measurement inertia (time constants equal a tenth parts of second and more) [Kluj, 2000].

It means, that for further diagnostic analysis an averaging values of the periodically changing exhaust flux temperature leaving the engine's individual cylinders, exhaust flux temperature in a cumulative passage feeding as well as exhaust flux temperature in the turbine escape passage are subjected - fig. 1. A proper interpretation of the temperature signal registered during the engine's steady working conditions represents the largest metrology difficulty [Wiśniewski 1983] and the principal problem, that a diagnostician has to deal with, is to answer on the following question: "How far do directly observed exhaust temperature

indications differ from a real values of the exhaust temperature which might be evaluated indirectly on the basis of the measurements of different thermodynamic medium's state parameters?". It consequently gives an opportunity to explain a special peculiar, and even apparent anomaly of the turbocharged engine's outlet exhaust system in which an averaging value of exhaust temperature leaving individual cylinders is considerably lower (even over 100K!) than an averaging exhaust temperature in the turbocompressor's inlet section.

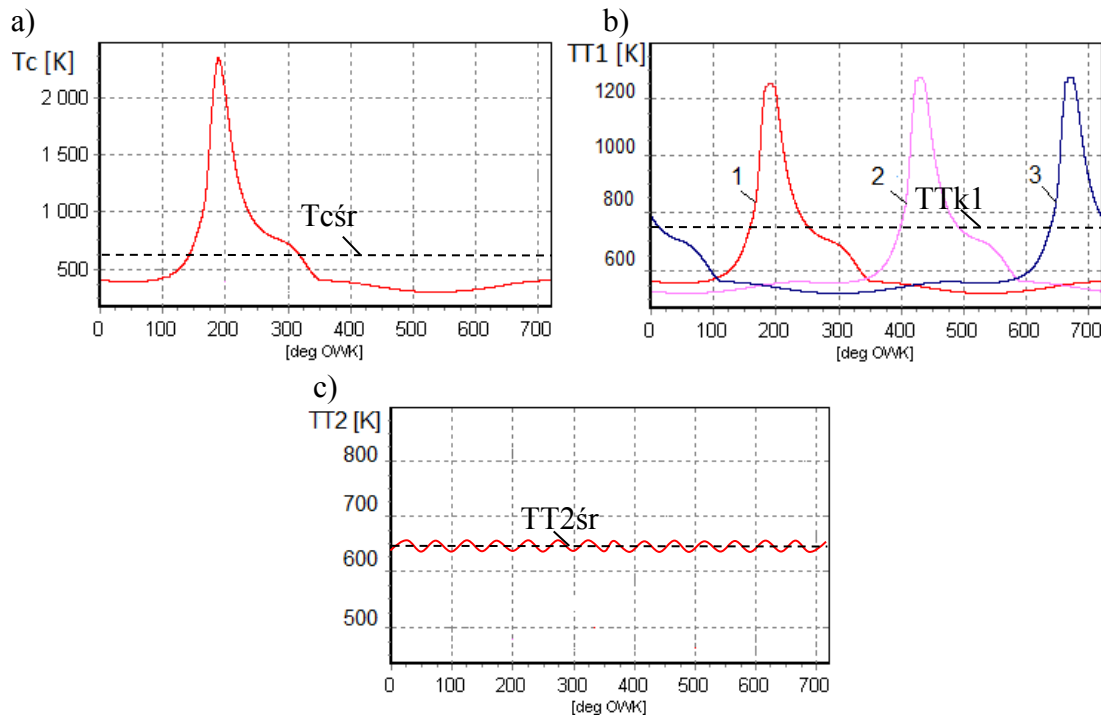

Fig. 1. Temperature alterations of the exhaust leaving an engine cylinder (a), in a cumulative passage feeding the turbine (b) and in a discharge passage of the turbine (c) in terms of an angle of the crankshaft revolution of the four-stroke engine.

2. EXHAUST FLOW THERMODYNAMICS

Energy processes worked out within the functional units of a marine engine with the pulsatory turbocharging system might be considered in steady and unsteady working conditions of the ship movement system¹ or ship electrical power system². Limiting the analysis only to the propulsion engine, it is assumed that the steady working conditions occur when derivatives of the state parameters of the analysed energy processes in relation to time equal to zero or they have got the settled periodical character and the period equals to the duration time of one working cycle (or equals its multiplicity resulting from a particular cylinders' number). Thus, the accumulation and dissipation processes of the energy and mass do not exist within the engine's functional units and average values of the all input and output energy streams are continually the same. In such a situation values of the basic parameters, e.g. the generated torque, the crankshaft's and turbocompressor rotor's angular speed as well

¹ Propulsion engine – propeller – ship hull.

² Propulsion engine - generator.

as the summary warmth stream flowing through the engine, averaging for the time corresponding to realization of several working cycles remain invariable.

However in reality, fluctuations of the alterations courses of the processes state's parameters occur. They come within a range of the engine's one working cycle and result, in peculiarity, from uniqueness of the burning process [Rychter and Teodorczyk, 2006, Wisłocki, 1991]. In such a way a "delamination" (sometimes considerable enough) of indicator diagrams is explain when the diagrams are registered from one working cycle to another at the immovable strip of the fuel injection's pump and invariable crankshaft's rotatory speed. If it causes the observable (within the accessible measuring techniques) alterations, in a time, of the average output engine's values it might be recognized that the unsteady conditions occur associated with an appearing the energy and mass accumulators in the engine's functional units.

In such a situation a simultaneousness consideration of the so called "micro-dynamic" processes (quick-changeable)³, worked out in the engine, which are associated with its cyclic work as well as "macro-dynamic" processes (slow-changeable)⁴ of the continuous flow of mass, warmth and energy streams in functional units occurred in relation to the first ones with a considerable delay requires a reasoning. A dynamics of the control process has to be also taken into consideration. Additionally, time constants of "macro-dynamic" processes worked out during unsteady working states of the ship movement system (or ship electrical power system) in relation to "micro- and macro-dynamic" engine processes have to be estimated. The ship movement system's inertia equals several up to dozens minutes [Wojnowski, 1998].

Restricting further considerations concerning an energy processes' dynamics of the pulsatory turbocharged engine only to the exhaust system's thermodynamics two conduct ways are possible. The first one, supposing, that the considered thermal-flow processes will be treated as the steady ones. In such a case full periodicity of these processes' course is adjusted and averaging values of the state parameters in a time considerably longer than the duration time of one engine work's cycle are accepted to calculate the values of thermodynamical medium state's function in the passage between cylinders and the turbocompressor.

The second approach supposes, that the courses describing quick-changeable thermal-flow processes in the exhaust passage are aperiodic, in a range of the one engine cycle's duration or aperiodic, in a range of the pathway time from one steady state to another (slow-changeable transient processes).

Thus, a qualification of the changeability character of thermodynamical medium state parameters and function time courses in the exhaust passage (their temporary values' measurement), in a sense of their periodicity: steady or unsteady, represents a key metrology issue. A deep and credibility of the formulated diagnosis about the engine technical shape as well as technical requirements towards the applied measuring apparatus (sensors' inertia, sampling frequency of the recorded signal measurement signal etc.) depend on the above mentioned factors.

3. RESEARCH OBJECT

The modelling object represents the turbocharging system of the 6-cylinder Sulzer 6AL20/24 four-stroke engine equipped with pulsatory power supply of the turbine and cooling supercharging air – fig. 2. The engine produces 420 kW nominal power, at crankshaft rotational speed 750 min^{-1} . Other the engine's technical data are, as follows: cylinder bore

³ Time constants from several to dozens milisecond.

⁴ Time constants from several to hundreds second.



and displacement - 200 mm i 7540 cm³, piston stroke and mean piston speed - 240 mm i 6,0 m/s, compression ratio - 12,7.

The system consists of sub-assemblies as follows: turbocharger's rotor with radial turbine (T) and radial compressor (S), flow passages of air and exhaust, cooler of the engine's supercharging air (CH). Measuring places for the engine control parameters are marked in the figure as well. The measurements are carried out by means of the computer measured-recording system during standard shipyard tests. Table 1 includes a set of the serial engine's observed parameters, registered during steady working conditions, at five different load.

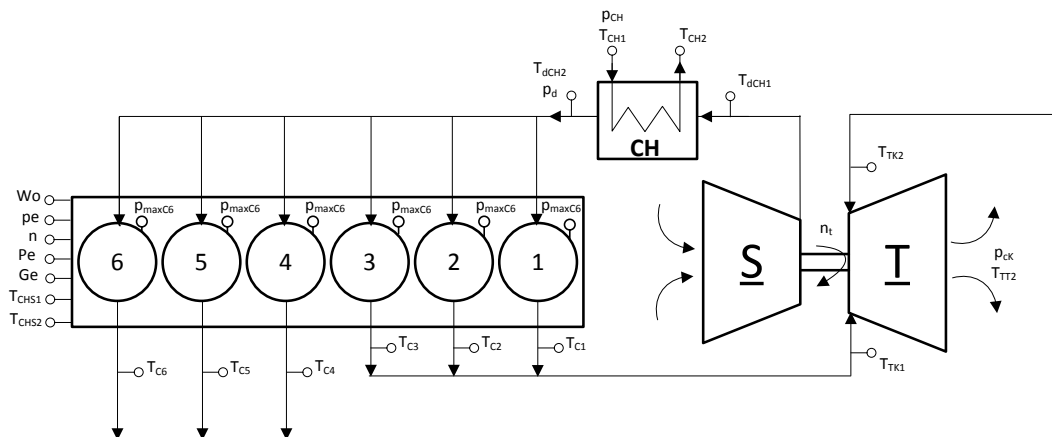

Fig. 2. Schematic diagram of the turbocharging system of the SULZER engine 6AL20/24 type

The singular supercharging system of the engine of firing sequence: 1-4-2-6-3-5 is equipped with a radial turbine having exhaust bipassage pulsatory power supply system. An alteration course of exhaust pressure in the pipes before the turbine wears a character similar to the one presented in figure 3. Such a solution, where the exhaust valve opening lasts $\alpha=340^0$ crankshaft revolutions, ensures positive interfering effect of pressure waves impulses from two cylinders by $\alpha=100^0$ OWK. Thanks to the phenomenon the lowest exhaust pressure in the outlet passages is higher than an outlet antpressure. This way, the improvement of turbine efficiency is obtained. Unfortunately, much more energy expenditures is needed to remove exhaust (an antpressure in the exhaust outlet passage is higher)⁵.

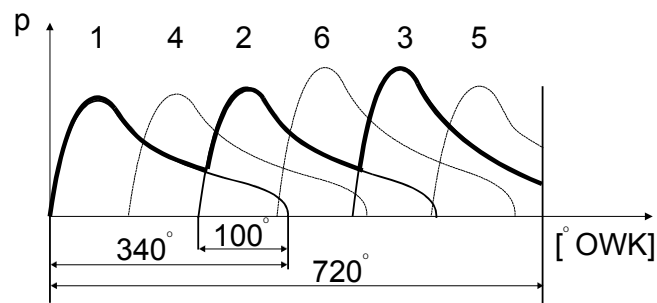

Fig. 3. Waveform course of exhaust pressure in the exhaust outlet ducts K1 (cylinder number 1-2-3) and K2 (cylinder 4-5-6) in front of turbine of the SULZER engine 6AL20/24 type

⁵ During the cylinder scavenging, in order to remove the biggest exhaust quantity, a pressure in the escape exhaust passage must be lower than the charged pressure.

That's why a suitable division within the engine's exhaust passage into individual branches is made. Cylinders are connected to them according to their ignition order, in such a way to avoid disturbing the scavenging process in one cylinder by escape impulses of the other one. Therefore, only exhaust outlets of cylinders, for which the self-ignition interval (measured in OWK degrees) is not smaller than exhaust valve's angle, might be connected to the common exhaust branch⁶. For example, looking at fig. 3, an amplitude of the exhaust pressure wave (an impulse) from cylinder No. 1 decreases up to the suitably low level, before the exhaust escape in cylinder No. 2 begins. Therefore an application of the branched exhaust makes it possible the average pressure's lowering in individual branches, and in result, reduces the pumping losses in the engine, fuel consumption as well as smoking during the acceleration process.

It is also well visible in fig 3, that the amplitude of the flowing through exhaust pressure waves of the cylinders laid in a central part of the escape passage, close to the turbine, decrease in relation to one of the cylinders whose outlets into the common escape passage are the most distant from the turbine⁷.

Tab.1. Basic and control parameters of the SULZER engine 6AL20/24 type ($p_{amb}=1014$ hPa, $T_{amb}=292$ K, $n.c.v.=41970$ kJ/kg)

Parameter	Load	0,25 Pe	0,50Pe	0,75 Pe	1,0 Pe	1,1 Pe
Crankshaft rotational speed – n [min ⁻¹]		750	750	750	750	750
Effective average pressure - p _e [MPa]		0,37	0,74	1,10	1,48	1,63
Effective power - P _e [kW]		105	210	314	419	461
Indicator of the engine's load: reg./eng. – Wo [-]		3,9/3,8	5,0/5,1	6,2/6,2	7,7/7,7	8,3/8,3
Hourly fuel consumption – G _e [kg/h]		26,4	46,8	68,6	90,1	100,8
Specific fuel consumption – g _e [g/kWh]		251,4	222,8	218,4	215,0	218,6
Cylinder pressure – maximum:						
cyl. 1 – p _{maxC1} [MPa]		6,4	8,4	9,7	11,2	12,1
cyl. 2 – p _{maxC2} [MPa]		6,4	8,5	10,0	11,4	12,1
cyl. 3 – p _{maxC3} [MPa]		6,2	8,7	10,1	11,5	12,4
cyl. 4 – p _{maxC4} [MPa]		6,5	8,6	9,8	11,3	12,1
cyl. 5 – p _{maxC5} [MPa]		6,2	8,4	9,7	11,5	12,4
cyl. 6 – p _{maxC6} [MPa]		6,4	8,5	9,7	11,2	12,2
Cooling medium:						
Pressure – p _{CH} [MPa]		0,24	0,24	0,24	0,24	0,24
Temp. in front/behind the air cooler – t _{CH1} /t _{CH2} [°C]		22/23	23/25	24/27	26/31	27/34
Temp. in front of the engine – t _{CHS1} [°C]		66	68	71	74	76
Temp. behind the engine – t _{CHS2} [°C]		72	74	78	81	83
Lube oil:						
Pressure – p _{ol} [MPa]		0,38	0,38	0,38	0,38	0,38
Temp. in front of the engine – t _{ol1} [°C]		56	58	60	62	64
Temp. behind the engine – t _{ol2} [°C]		66	68	70	72	74
Supercharging air:						
Pressure – p _d [MPa]		0,011	0,046	0,084	0,134	0,157
Temp. in front/behind the air cooler – t _{dCH1} /t _{dCH2} [°C]		42/24	72/28	96/33	130/43	140/47
Outlet exhaust:						
Temp. behind cyl. 1 – t _{C1} [°C]		255	285	315	365	365
Temp. behind cyl. 2 – t _{C2} [°C]		260	285	335	375	390
Temp. behind cyl. 3 – t _{C3} [°C]		235	280	310	340	355

⁶ It usually equals 240 degrees OWK for the four stroke engines.

⁷ Every pressure waves (impulses) lose the part of their kinetic energy in the way between the outlet valves and turbine guide vanes because of the friction, flow resistance through the turns etc.

Temp. behind cyl. 4 – t_{C4} [$^{\circ}$ C]	270	300	330	370	375
Temp. behind cyl. 5 – t_{C5} [$^{\circ}$ C]	270	295	315	350	365
Temp. behind cyl. 6 – t_{C6} [$^{\circ}$ C]	255	290	315	345	360
Temp. av. behind cyl. – t_{Csr} [$^{\circ}$ C]	258	289	320	358	368
Temp. in front of a turbine (cyl. 1,2,3) – t_{Tk1} [$^{\circ}$ C]	305	395	450	495	510
Temp. in front. of a turbine (cyl. 4,5,6) – t_{Tk2} [$^{\circ}$ C]	320	390	440	485	505
Temp. behind the turbine – t_{TT2} [$^{\circ}$ C]	265	325	350	360	380
Losses of the total pressure in the exhaust passage (exhaust back-pressure) – p_{ek} [Pa]	400	800	1500	2500	2800
Fuel pressure in front of the engine – p_{pal} [MPa]	0,24	0,24	0,23	0,23	0,25

This phenomenon results from a character of the expansion process in central cylinders where exhaust expansion is carried out in both directions: towards the turbine and towards the passage's beginning. The amplitudes decrease is greater when a volume of side branches of the connecting channel is greater [Korczewski and Zacharewicz, 2012].

4. EXHAUST TEMPERATURE MEASUREMENT TECHNOLOGY

Within the considered marine engines having a pulsatory turbocharging system the exhaust escaping from the cylinder heads flows towards the turbocompressor with high speed (much more than 50 m/s ⁸), in the beginning, through the heat insulated connecting turns, then - through the insulated cumulative passage at constant cross⁹ – fig. 4. Thermal deformations of the passage are taken with the compensators made of the high temperature resistant material. They are put between the individual passage parts – fig. 5.

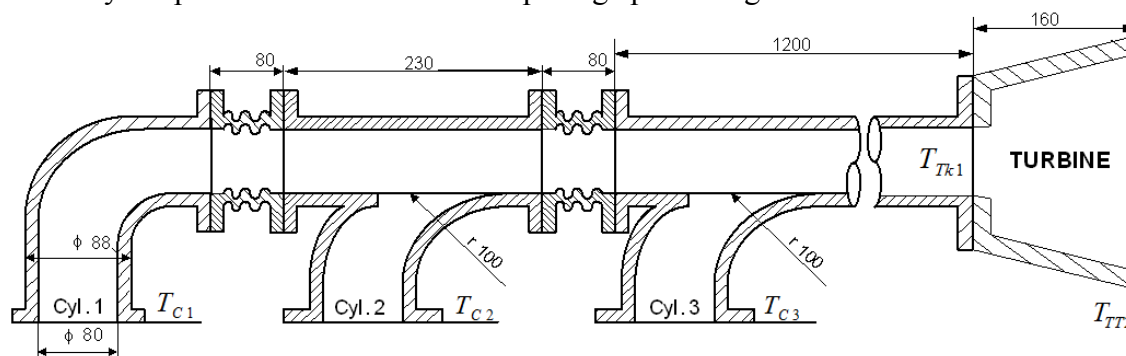

Rys. 4. Schematic diagram of the exhaust passage

⁸ Durnig cylinders scavenging, at the moment of exhaust valve opening, an acoustic longitudinal wave (pressure) is generated. It displaces with the local sound velocity in relation to the flowing exhaust parts stream.

⁹ As was explained in a foregoing chapter at least two such passages are applied in a pulsatory exhaust powered system of a turbocompressor of six-cylinder engines.

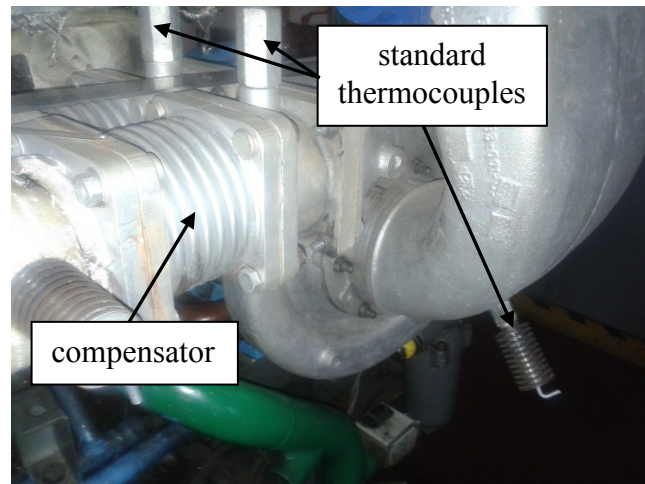

Fig. 5. Principal view of the passages feeding turbocompressor in the pulsatory system

The process might be treated, in an engine's work steady conditions, as a periodically changing flow (steady) and energy isolated i.e. adiabatic, without making a technical work [Wiśniewski, 2005]. Friction losses associated with a flowing exhaust's viscosity are additionally taking into account (irreversible adiabate). In such a situation, assuming that a quantity of exhaust flowing in a time unit does not change, the exhaust enthalpy stream in cross-section of the passage connecting cylinders and turbocompressor stays invariable as well:

$$\dot{H}^* = \dot{m} \cdot c_p \cdot T^* = idem \quad (1)$$

However, the parts of individual components of the exhaust enthalpy stream change. They represent kinds of energy¹⁰, as follows – fig. 6:

- kinetic energy $e_k = \frac{c^2}{2}$,
- pressure energy (forcing through) $e_p = \frac{p}{\rho}$,
- internal energy $u = c_v \cdot T$.

¹⁰ Exhaust stream potential energy alterations represent irrelevant and omitted position of the energy balance.

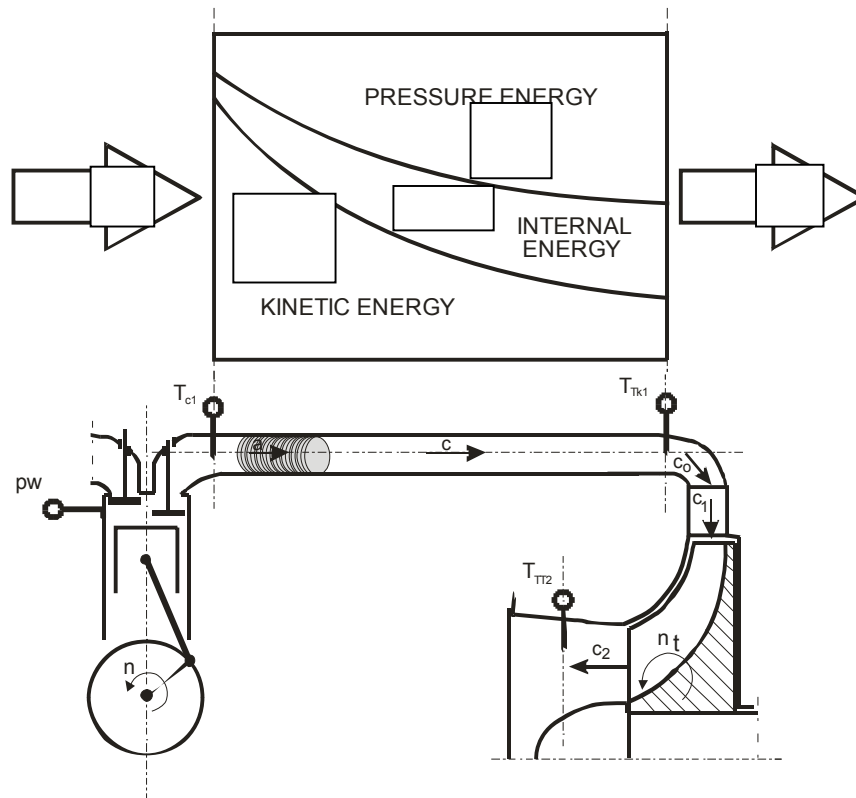

Fig. 6. Alterations course of the energy in the exhaust passage

Therefore, within a turbocompressor feeding system successive impulses of the hot exhaust escaping engine's cylinders compress adiabatically the gas column located in front of them [Woodyard, 2004]. Because of growing hydraulic resistances a flow decrease and dissipation of concentrated medium's kinetic energy take place as a cost of a growth of its internal energy (working medium absorbs the arising friction warmth) and pressure energy (forcing through work). A drop of exhaust velocity as well as a growth of exhaust static temperature and pressure in an inlet cross-section of the turbocompressor's turbine stand for the observable symptoms of the phenomenon. Moreover, the growth of exhaust temperature in front the turbine can be so considerable, that it exceeds a temperature value directly behind the cylinders, even 100 K (and more).

The above described phenomenon is not the only cause of the observed exhaust temperature growth in a feeding passage of the turbocompressor. There should be additionally consider another factors having an essential impact on the observed anomaly.

1. In the exhaust passage, which is made of creep-resistance steel or stainless, the reaction of catalytic oxygenation of the unburnt hydrocarbonaceous particles takes place (after-burning). It occurs on the flowing passage's internal surface in the presence of iron oxides (catalytic influence of iron oxides e.g. Fe_2O_3), what explains the growth of exhaust temperature in front of the turbine.
2. A thermocouple placed directly behind the exhaust valve registers an average temperature of the exhaust stream impulse. It is subject to the influence of the very hot exhaust in an initial period of their outflow, and then to the influence of the considerably colder mixture of the exhaust and the loading air, within a period of cylinders' scavenging. The hot particles of the exhaust stream from another cylinders do not reach this place from (however, the exhaust pressure waves - primary and returned might reach). On the contrary, a thermocouple placed in the cumulative passage feeding a turbocompressor, directly in front of a turbine, is subject to influence of the following impulses of the exhaust stream, with three times (it depends on a number of cylinders connected to this

passage) larger frequency than thermocouples placed in the individual branches of the exhaust passage, directly behind the cylinders. Hence, the occurring growth of average exhaust temperature in front of a turbocompressor in relation to ones behind the engine cylinders.

An excessive growth of the exhaust temperature escaping a cylinder is particularly dangerous for cylinder valves' reliability, however exceeding its admissible value in an inlet cross-section of the turbocompressor may cause extensive and usually irreversible damages of the turbine's rotor blades and guide vanes. Just, with regard to above mentioned reasons - this parameter is monitored on-line during an operation process of contemporary marine diesel engines.

There are many operation causes of an excessive growth of the escaping exhaust temperature. In case of the marine engine it usually stands for the consequence, as follows:

- a) an excessive engine's load, in the result of a hulk sprouting or damages of the propellers' wings (collisions, entry on shallow etc.);
- b) performance disturbances of the jacket water cooling installation (choked passages in result to the hard removable fouling deposits, aerated water spaces etc.);
- c) fouling the exhaust passage (a layer of the fuel incomplete burning's products settling down on the passage's internal surfaces as well as on surfaces of the turbine's rotor blades and guide vanes stands for a reason of the exhaust active cross-sections flow's decrease along with the further, besides the exhaust temperature's growth, consequences for the engine and turbocompressor's efficiency and reliability [Piotrowski i Witkowski, 2002];
- d) performance disturbances of the executive mechanism of the turbocompressor's feathering paddles' control system (deformations, fouling, cracks, seizures etc.);
- e) disturbances of the fuel combustion process worked out in engine's cylinders, because of:
 - incorrect performance of the engine's fuel fed system (low fuel quality, failures of the injection's pump or injectors - fig. 7),
 - dysfunction of the supercharging air system (obstructed filter on the air compressor's suction, fouled cooler, failures of the compressor's rotor blades or diffuser);
 - performance disturbances of the working medium timing gear (inlet and exhaust valves' seat, face or head wear and tear, worn out elements of the valve propulsion system – mechanical, hydraulic, pneumatic).

Another reason of the excessive growth (usually violent) of the escape exhaust temperature, in case of two-stroke engines, might be lube oil mist's self-ignition in a loading air container (resulted, the most often, from a returnable flow of hot gases from cylinders to the container through leaky piston rings [Scott, 2011]).



Fig. 7. Picture of the possible disturbances of the injectors' performance – a set of the same engine [www.intercars.com.pl]

5. CONCLUSIONS

The introduced in article method of a technical state evaluation of a marine diesel engine with pulsatory supercharging system consists in standard exhaust temperature measurements carried out in characteristic control section of the engine' thermal-flow unit during steady working conditions of the ship movement system. It represents the base for the further, deeper diagnostic investigation on the assumption that the function courses describing quick-changeable thermal-flow processes working out in the exhaust passage are aperiodical within the scope of the engine's one working cycle duration.

Such an approach requires developing the new measurement technology which enables a diagnostician to evaluate exhaust temperature's instantaneous values in the passage connecting cylinders to the turbocompressor while the engine is in current operation. It allows precise determination of an alteration character of the disposed enthalpy flux feeding the engine's turbocompressor. It is foreseen to apply, for this aim, two thermocouple of different diameters, made of the good thermal conduction and small thermal inertia material as well as proper adapting a measuring method which was firstly proposed by H. Pfriema in 1936.

REFERENCES

- [1] Korczewski Z., Zacharewicz M.: Alternative diagnostic method applied on marine diesel engines having limited monitoring susceptibility. Transactions of the Institute of Measurement and Control, Great Britain SAGE - Vol. 34, No. 8/December/2012, 2012, p. 937-946.
- [2] Kluj S.: Diagnostyka urządzeń okrętowych. Wydawnictwo monograficzne. AM Gdynia 2000.
- [3] Pfriem, H.: Zur messung veränderlicher temperaturen von gasen und flüssigkeiten (On the measurement of fluctuating temperatures of gases and fluids). Forschung auf dem Gebiete des Ingenieurwesens, 7(2)/1936, pp. 85-92 (in German).
- [4] Piotrowski I., Witkowski K.: Eksploatacja okrętowych silników spalinowych. Wydawnictwo monograficzne. Akademia Morska, Gdyni 2002.
- [5] Rychter T., Teodorczyk A.: Teoria silników tłokowych. WKiŁ, Warszawa 2006.
- [6] Scott W.: Diagnosing Causes of High EGT in Marine Engines. Marine Machinery, Engines & Controls. Edited by Lamar Stonecypher (updated: 11/2/2011).
- [7] Wisłocki K.: Systemy doładowania szybkoobrotowych silników spalinowych. WKiŁ, Warszawa 1991.
- [8] Wiśniewski S.: Termodynamika techniczna. WNT, Warszawa 2005.
- [9] Wiśniewski S.: Pomiary temperatury w badaniach silników i urządzeń cieplnych. WNT, Warszawa 1983.
- [10] Woodyard D.: Pounders marine diesel engines and gas turbine. Great Britain ELSEVIER, 2004 (eighth edition).
- [11] Wojnowski W.: Okrętowe siłownie spalinowe. Część I. Akademia Marynarki Wojennej. Gdynia 1998.
- [12] www.intercars.com.pl