

Extraction with environmentally friendly solvents

Justyna Płotka-Wasyłka, Małgorzata Rutkowska, Katarzyna Owczarek,
Marek Tobiszewski, Jacek Namieśnik

Department of Analytical Chemistry, Faculty of Chemistry, Gdańsk University of Technology, 11/12 Narutowicza Street, 80-233 Gdańsk, Poland

a b s t r a c t

The ever-increasing demand for determining compounds at low concentration levels in complex matrices requires a preliminary step of analytes isolation/enrichment in order to employ a detection technique characterized by high sensitivity at low LOQ. Sample preparation is considered as crucial part of analytical procedures. Previously the parameter of "greenness" is as important as selectivity in order to avoid using harmful organic solvents in sustainable extraction techniques. These solvents can generate hazardous, toxic waste while consuming large resources volume. Developing new green solvents is one of the key subjects in Green Chemistry in order to reduce the intensity of anthropogenic activities related to analytical laboratories. A lot of new, more eco-friendly media have been employed as extractant phases. These media, besides of being more eco-friendly, provide shorter extraction times, simplicity, low cost, better selectivity in some cases. The most promising, most widely used green extraction solvents are described in this review.

Keywords: Surface active agents, Supercritical fluids, Superheated water, Ionic liquid, Deep eutectic solvent, Bio-derived solvent

1. Introduction

There is no doubt that preparation of samples for analysis is vital especially if trace and ultratrace constituents are object of interest. Isolation of analytes from samples characterized by complex non-homogenous composition of the matrix could be treated as one of the biggest analytical task. Very often this step of analytical protocols is simply named extraction. There is a large variety of extraction techniques and approaches. Different parameters can be used for classification of extraction techniques. As the most popular one can mention:

- number of phases in contact,
- time,
- level of automation,
- mode of connection with analytical instrument,
- type of extraction medium,
- field of application,
- impact on the environment.

Field of the application of different types of the extraction techniques is increasing constantly. Authors should mention such

areas as liquid–liquid extraction, Soxhlet extraction, accelerated solvent extraction as well as solid phase extraction that are widely used in a variety of applications such as separations in analytical chemistry, industrial processes in hydrometallurgy, food engineering, pharmaceutical and waste treatment [1]. In these techniques, volatile organic compounds (VOCs) including halogenated hydrocarbons, aliphatic and aromatic hydrocarbons, some esters, alcohols, ethers, aldehydes and ketones are mainly used as an organic phase solvents. It is well known that many of these VOCs are toxic, highly flammable and detrimental to the environment. Therefore, the attention should be paid to solvents applied for the extraction due to the aforementioned reasons and thus, a new, more eco-friendly solvents should be found and introduced. Developing sustainable solvents is perhaps the most active area of green chemistry and green analytical chemistry (GAC). In fact, several principles of green chemistry and GAC directly or indirectly refer to this problematic issue [2]. Looking at these principles, already at first glance can be seen that the 5th principle of green chemistry refers to the avoidance of solvents separation agents, or other auxiliary chemicals from chemical laboratories whenever possible or their replacement by innocuous alternatives. In addition, other green chemistry principles are also connected directly or indirectly with minimize of solvents application, for instance principle 1st (waste prevention), 3rd (use and generation of substances that possess little or no

toxicity), 4th and 10th (design of safer, non-persistent and biodegradable chemicals), 5th and 7th (use of innocuous auxiliary substances and renewable feedstocks), and the last 12th (inherently safer chemistry for accident prevention) [2]. Therefore, the performance of solvent-free processes would be ideal. However, considering crucial role of solvents in dissolving solids, mass and heat transfer, influencing viscosity and in separation and purification steps, their application is almost unavoidable. Introduced in the early 1990s solid-phase microextraction represents a paradigmatic example of the solventless enrichment technique, especially when combined with thermal desorption. Some other sample preparation approaches such as open tubular traps, inside needle capillary adsorption trap, needle trap device, solid phase dynamic extraction, and single- and multi-bed adsorption systems can be operated likewise without making use of solvents. In addition, several liquid-phase microextraction approaches that minimized solvent consumption exist [2]. However, as was mentioned above the full phase-out of solvents is not always feasible and solvent reduction and replacement represents the 'least bad' approach in these cases. Furthermore, organic solvents are often required as modifiers to improve the efficiency of extraction (even with essentially solvent-free techniques) and to carry out derivatisation and/or liquid desorption. Taking all this into account it is no wonder that developing green solvents is a high priority.

What the green solvent is? The idea of "green" solvents expresses the goal to minimize the environmental impact resulting from the use of solvents in chemical production [3]. Moreover, few other aspects are assessed to consider a solvent as green, such as health and safety issues, the indirect impacts derived from their production, use and disposal including, for instance, depletion of non-renewable sources, and potential solvent recycling and energy consumption in their synthesis, recycling and waste treatment [2].

Taking this into account, several solvents that can be used in extraction process may be named "green solvents". Undoubtedly, water and carbon dioxide: two innocuous and renewable solvents which are well known in analytical laboratories may be included to this group. The most popular solvent applied in analytical process is water. Moreover, due to the possibility of changing the physico-chemical properties of water with temperature and pressure the applications of water in analytical chemistry are even more expanded, for instance in subcritical extraction processes of less polar compounds [4]. Carbon dioxide is commonly applied under supercritical conditions in extraction processes. Wide application of carbon dioxide as a supercritical fluid results mainly from its advantageous supercritical temperature and pressure conditions (31°C and 73.8 bar), its economy and environmental friendliness. In literature, several comprehensive reviews regarding the use of water [5,6] and carbon dioxide [6,7] in analytical methodologies exist.

Surface active agents also should be included in green solvents group. Surfactants are used for the extraction for many years and a broad spectrum of sample preparation techniques has been developed. These techniques have such advantages as low cost, nontoxic extractant, simplicity and high capacity to concentrate a wide range of analytes.

Another class of green solvents is ionic liquids (ILs) which attracted growing interest due to their unique physicochemical properties. It may be seen in the increase of application of ILs as analytical solvents, especially in many sample preparation techniques as a "green" alternative for volatile organic solvents. An alternative to ILs are deep eutectic solvents (DESs) which have comparable characteristics to ILs but are cheaper to produce due to lower cost of the raw materials, less toxic, and often biodegradable

[8]. However, the high viscosity and solid state of most DES at room temperature restrict their application as extraction solvents. Recently, new type of extraction solvents, natural deep eutectic solvents (NADES) were introduced to the analytical practice. Besides all the advantages of DES, NADES are even more environmentally friendly due to their natural origin [9]. This paper reviews the most promising and most widely used green extraction solvents.

2. The environmentally sustainable solvents applied in extraction process

For many years organic solvents and their aqueous solutions have been the main extractant phases used in analytical laboratories. However, because of the increasing consciousness regarding environmental cases, the scientists were encouraged to search and introduce new, more benign, clean and safe extractants. The most promising and most widely used green extraction solvents are described in the next part of this chapter.

2.1. Surface active agents

Surface active agents, also called surfactants, are amphiphilic molecules composed of polar "head" group connected to hydrophobic "tail" group. These compounds may be classified as:

- anionic surfactants, containing anionic functional groups at the head,
- cationic surfactants, containing cationic functional groups at the head,
- zwitterionic surfactants, that have both anionic and cationic moieties at the same molecule, and
- non-ionic surfactants.

Surfactants, in low concentrations in the aqueous solution, usually occur in dissolved form. After exceeding the characteristic concentration, called critical micelle concentration (CMC), surfactants molecules start accumulate to form clusters – micelles and cloudy solution is formed. Micelles shapes (depicted in Fig. 1A) depend on the specific solution conditions and surfactant type [10].

Regardless their shape, micelles are colloidal system, where aggregate sizes are smaller than visible light wavelength, so the solution is transparent. In aqueous and other polar media, surfactant molecules aggregate with their hydrophobic tail oriented towards the centre. In the result non-polar areas are created within the polar solvent. If the medium is non-polar, reversed micelles are formed with their heads inside the structure.

The process of absorbing compounds by micellar phase is called solubilization. From the analytical chemistry point of view, the main advantage of these structures is their capacity of solubilize species of different nature. Thus, the solubility of many chemicals that are poorly soluble in water is significantly higher in the presence of micellar phase dispersed in the aqueous medium. In the organic phase, the reversed micelles perform the same role in case of hydrophilic compounds. After extraction process, surfactant-rich phase is separated usually by centrifugation or properly altered conditions like temperature and pressure [10,11].

Surfactants are used for the extraction for many years and a broad spectrum of sample preparation techniques has been developed. These techniques have such advantages as low cost, nontoxic extractant, simplicity and high capacity to concentrate a wide range of analytes.



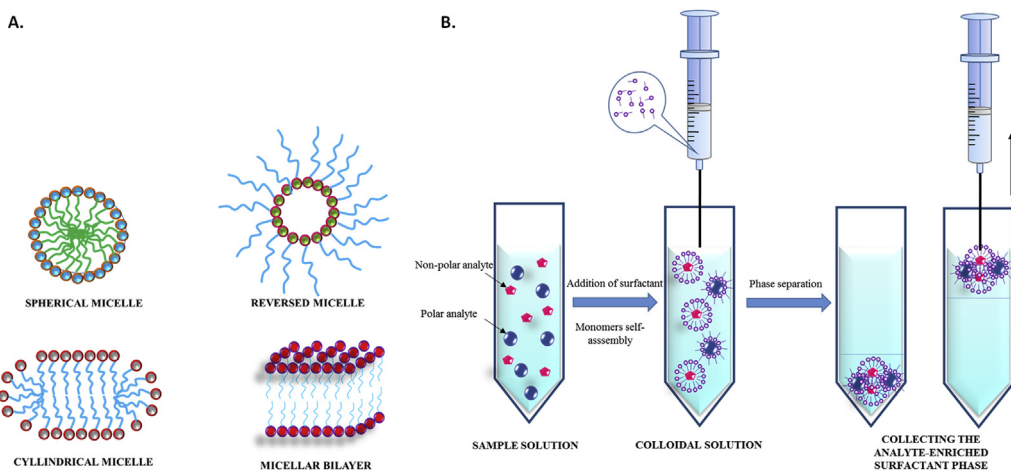

Fig. 1. Schematically shown micellar shapes (A) and procedure steps and scheme of the basics of micellar extraction (B).

The first coacervate-based extraction method was cloud-point extraction (CPE) or micellar extraction, first introduced in the 1970s. This type of extraction, regarding abovementioned advantages, is very popular until now and is a convenient alternative to liquid–liquid extraction [11]. The process of extraction of the target compounds with surfactants consists of [12]:

- solubilization of analytes for micellar aggregates – compounds present in the original matrix bound to the micelles, clouding of the solution by adjusting the temperature and pressure. It effects that solution becomes turbid,
- separation of phases (surfactant rich phase with target analytes, and the matrix).

Coacervative extraction (CAE) is a technique that is very similar to CPE. The difference between these methods lies in the processes involved in the forming of the micellar phase. In CAE factors other than temperature and pressure are used, like addition of the salt or adjusting the pH.

In every case, the extraction conditions should be optimized, which can be gained by:

- adjusting the solution pH,
- selection of the proper surfactant and adjusting its concentration,
- duration of the process,
- optimisation of the temperature.

The use of auxiliary energy, like ultrasound and microwaves is also an important factor that may significantly increase the efficiency of the micellar extraction, decrease the amounts of organic solvents necessary for the extraction and reduces the extraction time. The coacervative extraction process scheme is given in Fig. 1B.

Application of micellar extraction is very broad (Table 1). This method can be applied in extraction of persistent organic pollutants like PAHs or PCBs, heavy metals or pesticides from environmental samples [11–14]. In the recent years micellar extraction is also involved in the case of analytes of biological interest like antibiotics, or in food analysis [15].

An interesting topic that is connected with coacervative extraction is extraction using supramolecular solvents. These nano-structured solvents are obtained with surfactants by the self-assembly processes occurring in nano and molecular scale. Supramolecular solvents have a wide spectrum of unique

physicochemical properties that are useful from analytical point of view like:

- tunability (by manipulating the polar and hydrophobic group of the amphiphile)
- very good solvation properties for a great number of chemical compounds
- non-volatility and non-flammability [16].

2.2. Supercritical fluids

A substance goes into supercritical state when its forced to a pressure and temperature above the critical point. Physicochemical properties of supercritical fluid are placed between the liquid and the gas, so this state has been defined as a state when liquid and gas cannot be distinguished. A substance that became supercritical fluid has density similar to liquid, viscosity of a gas diffusivity in-between of these two states [17].

Compared with conventional extraction techniques such as solid–liquid extraction, Soxhlet extraction or classic solvent extraction, besides decreased consumption of toxic solvents and better selectivity, SFE is characterized also by some additional advantages:

- better mass transport resulting from low viscosity and high diffusivity is desired especially in case of extraction of target compounds from solid samples; because supercritical fluid can easily diffuse through a solid sample matrix, faster extraction is achieved;
- better efficiency by increasing extraction yields and use of smaller amounts of solvents;
- possibility of direct coupling of SFE with analytical instrumental techniques like GC [17];
- possibility of modifying physical conditions (like density) to extract the target compounds [18];
- SFE produces no toxic residues [19].

Because of mentioned advantages, supercritical fluid extraction is an important process in such fields as food, pharmaceutical and cosmetic industries. This method is a powerful tool in the case of the extraction of natural compounds from food products. It has been applied in essential oils and drug extraction from natural matrices, extraction of lipids and bioactive compounds, enantiomeric separation and enzymatic reactions, extraction of persistent

Table 1
Information on application of different type of solvents used in the extraction process.

Analyte type	Matrix type	Solvent used	Final detection technique	Recovery [%]	Ref
Ionic liquids					
Sulfonylurea herbicides	Wine	([C ₆ MIM][PF ₆])/IL-DLLME	Capillary-HPLC	79–106	[35]
Methamphetamine	Human urine	([C ₈ MIM][PF ₆])/IL-DLLME	HPLC	81.6	[36]
Pb and Ni	Biological samples	([C ₆ MIM][PF ₆])/HF-LPME	ETAAS	95–105	[37]
Fungicides	Environmental water samples	([HMIM][PF ₆])/IL-SDME	HPLC	74.9–96.1	[72]
Superheated water (SW)					
PAHs	Soil, sediments	SW: 300°C	LC–GC	–	[25]
Pesticides	Environmental solids	SW: 110°C	GC–MS, HPLC–MS	–	[46]
Polychlorinated benzofurans	Industrial soils and sands	SW: 300–350°C	GC–MS	–	[27]
Berberine	<i>Berberis vulgaris</i>	SW: 110–170°C	HPLC	–	[40]
Glycyrrhizic acid	Licorice root	SW: 200°C	RP-HPLC–UV	–	[23]
Surface active agents					
Aristolochic acids	Biological samples	Genapol X-080	HPLC–UV	94.5–105.4	[73]
Sulfonamides	Soil, sediment, sludge	Triton X-114	HPLC–UV	69.7–102.7	[74]
Pharmaceutical compounds (caffeine, ornidazole, carbamazepine, ketoprofen, naproxene)	Wastewater taken from WWTP	Polidocanol	UHPLC-DAD	72–133	[75]
Acetoin	Butter	Triton X-100	HPLC	96.2–107.8	[15]
Supercritical fluids					
Anthocyanin	Jamun fruits	CO ₂	SCF	–	[76]
Phenolic compounds (proanthocyanidins)	Grape marc	CO ₂ + EtOH/H ₂ O	SCF	–	[77]
Oils and fatty acids	Microalgae (<i>Scenedesmus obliquus</i> , <i>Chlorella protothecoides</i> and <i>Nannochloropsis salina</i>)	CO ₂ + EtOH	SCF	–	[78]
Deep eutectic solvent					
Flavonoids	Plant sample – <i>Equisetum palustre</i> L.	Choline chloride–betaine hydrochloride–ethylene glycol	HPLC	7.14–89.25%	[79]
Co(II)	Pharmaceutical supplement, tea samples	Choline chloride–phenol	MS-FAAS	97–105%	[52]
As, Cr, Mo, Sb, Se, V	Soil samples	Choline chloride–oxalic acid	ICP OES	98–103%	[80]
NADES					
Gluten	Raw, processed food (spaghetti labelled as 'gluten-free'), biscuits with and without gluten, and ham (labelled as 'gluten-free')	Glucose–citric acid, glucose–tartaric acid, fructose–citric acid, sucrose–citric acid, betaine–citric acid, choline–citric acid	Spectrofluorometry	79–106%	[81]
Polyphenolic compounds	Plants samples: dittany, fennel, marjoram, mint, sage	Lactic acid–choline chloride, lactic acid–sodium acetate, lactic acid–ammonium acetate, lactic acid–glycine–water	Diode-array spectrophotometer (GAE)	–	[82]
Flavonoids: rutin, quercetin, kaempferol, daidzein	Botanical matrices	Glucose–choline chloride–water	UHPLC, NMR/quantitative NMR	95–97%	[83]
Bio-derived solvents					
Triglycerides, diglycerides, monoglycerides	Microalgal cells	BD40 containing 40% of biodiesel in ethanol	GC–MS	116%	[84]
La(III), Pr(III), Nd(III), Eu(III), Gd(III), Er(III), Yb(III), Lu(III), Y(III)	Rare earth	CA-12-SBME	MS	–	[85]
Lipids	Marine microorganisms (spirulina, Phormidium, Anabaena, Stigeoclonium)	Limonene; limonene:ethanol	GC–MS	70–73%	[86]

HPLC – High Performance Liquid Chromatography, GC – Gas Chromatography, MS – Mass Spectrometry, LC – Liquid Chromatography, ETAAS – Electrothermal Atomic Absorption Spectrometry, DAD – Diode Array Detector, ICP OES – Inductively Coupled Plasma–Optical Emission Spectrometry, FAAS – Flame Atomic-Absorption Spectrometry, RP – Reversed Phase, TOF-MS – Time of Flight Mass Spectrometry, UHPLC – Ultra High Performance Liquid Chromatography, NMR – Nuclear Magnetic Resonance.



organic pollutants (PAHs, PCBs) from environmental samples (Table 1).

SFE consists of two main stages [18]:

- Extraction of the soluble compounds from the matrix, when solid sample absorbs the supercritical solvent. In the result, analytes are dissolved from matrix by the solvent;
- Separation of the analytes from the supercritical solvent, when analytes are transported and then removed.

The step of appropriate solvent selection is crucial. In fact, any solvent may be brought to the supercritical state, but some factors must be taken under consideration. These factors are toxicity of the solvent, its physicochemical properties that affect the conditions of supercritical state, technical viability and cost. Although carbon dioxide, because of its moderate critical temperature and pressure, is most widely used for this purpose, other solvent have also been studied.

Ethane was used for extraction of caffeine, theobromine and cocoa butter from cocoa beans [20]. Critical properties of ethane are similar to these of CO₂, but the pressure necessary to gain supercritical state is lower, which makes the extraction process less energy-consuming. Comparing to the supercritical carbon dioxide, higher extraction yields were obtained. The main drawback of the ethane as SC solvent is its high cost, however taking into account that less energy is needed, the choice of this solvent should be taken under consideration.

Alternative for 'conventional' choice of CO₂ are propane and dimethyl ether. It was studied in the case of extraction of oleoresin and gingerol from ginger [21]. Both solvents provided better extraction efficiency than CO₂. Probably it was effect of co-extraction of water, due to mutual solubility of water and dimethyl ether [18,21].

One of the drawbacks of the SFE using CO₂ as a solvent is need to use an organic modifier (co-solvent). The extraction efficiency is significantly improved by the modifier by increasing the solubility of the target compounds in CO₂ (interactions between solute and co-solvent), especially in the case of highly polar species. Generally, the amount of the modifier added varies from 1% up to 15%, but this factor is determined by type of the matrix, type of co-solvent, extraction conditions and type of the solute. Methanol and ethanol are frequently used as the co-solvents, but the choice of the appropriate substance is not always easy and a number of factors (e.g. type of the target compounds, affinity of the analytes to modifier) have to be taken under consideration [17].

The application of the organic modifier is obviously decreasing the "greenness" of the SFE method, but the volumes of co-solvents are usually relatively low. Moreover, some attempts to use non-toxic substances of natural origin like vegetable oils in the role of co-solvent have been made. Canola oil was employed as modifier for the SC-CO₂ extraction of the carotenoids from carrots, increasing the yield up to 7–10% [22].

Preparative supercritical fluid chromatography (SFC) was compared with preparative HPLC system in terms of material and energetic demands. Depending on the factors used for comparison, that were quantified in terms of resources and expressed as exergy, the assessment results differ to great extent. It was calculated that on the separation process and plant levels SFC performs better than HPLC. However, if high energetic demand to produce CO₂ in supercritical state is considered, the performance of HPLC is better than SFC. These results do not refer to extraction process but show that supercritical fluid technology does not have to be always preferential over classical solvents systems.

2.3. Superheated water (subcritical water)

Water is probably best-known and most widely used solvent. Water is at the same time very unique substance, due to its hydrogen-bonded structure, high boiling point temperature and polarity. Heating water to the temperatures range between 100°C and 374°C (over boiling point and below critical point) and increasing the pressure over atmospheric values, to maintain liquid state, causes change in the physicochemical properties. Superheated (subcritical) water becomes less polar, its permittivity, surface tension and viscosity decrease when diffusion rate increases [23]. Dielectric constant, which decreases in the high temperature is very important factor. In the room temperature it is 80, but at 250°C it decreases to 27, which is near dielectric constant of ethanol at room temperature. These properties make the wider group of polar and non-polar analytes soluble in water.

Extraction using superheated water as a solvent brings a number of benefits. It may be an effective alternative for conventional organic solvents. Water is non-toxic, easily available and cheap. Hence, superheated water extraction provides selective, fast and environmentally friendly method for extraction of polar and moderately polar analytes from solid samples [14,24]. However it must be noticed that extraction power of water is limited, and separation of analytes from aqueous phase is sometimes problematic. The diagram of the set-up for carrying out of extraction of solid materials sample with the stream of hot water is presented in Fig. 2.

For most extraction methodologies distilled, deionized, degassed or flushed with nitrogen (to remove oxygen) water is used. Sometimes also pH control is employed to enhance selectivity towards target compounds. In some cases an addition of small amounts of organic solvent is necessary, e.g. for separation of analytes from aqueous phase or because sometimes the extraction power of superheated water is limited. In Table 1 information on different use of Superheated Water Extraction (SHWE) – knows also as Hot Water Extraction (HWE), Pressurized Hot Water Extraction (PHWE) or Subcritical Hot Water Extraction (SWE) – is given.

The first use of SWE was in 1994 for extraction of polar and non-polar compounds from soils. Since that time, SHWE is used mainly as an extractant of compounds such as PAHs, PCBs, pesticides and polychlorinated benzofurans from environmental solid samples [25–27]. It is also an efficient method for extraction of natural,

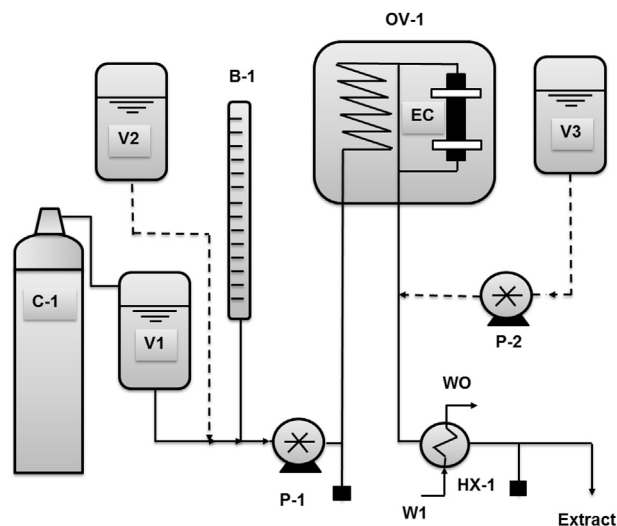

Fig. 2. The diagram of the set-up for carrying out of extraction of solid materials sample with the stream of hot water.

essential oils and bioactive compounds from foodstuffs and plants and for environmental remediation. Moreover it was shown, that SWE is more efficient in extracting natural phenols from plants than Soxhlet extraction, ultrasound and microwave assisted extraction. Extracts obtained by SHWE were also more biologically active.

Superheated water extraction in most cases provides extraction yields similar to such techniques as Soxhlet extraction or SFE. In case of PAHs extraction with SWE is slightly faster. On the other hand, alkanes are poorly extracted by SWE. It is worth notice, that with similar extraction efficiency, water is still the cheapest and least toxic solvent.

2.4. Ionic liquids as solvents for extraction

In recent years ionic liquids have attracted growing interest, because of their unique physicochemical properties. It may be seen in the increase of application of ILs as analytical solvents, especially in many sample preparation techniques as a "green" alternative for volatile organic solvents.

Ionic liquids are a group of non-molecular compounds, with melting point below 100°C, unlike common molten salts. Typically they consist of big, asymmetric organic cation (e.g., imidazolium, pyrrolidinium, pyridinium, tetraalkyl ammonium or tetraalkyl phosphonium) and smaller organic or inorganic anion (e.g., tetrafluoroborate, hexafluorophosphate, bromide). Various common cations and anions described in literature from which functional variations of room-temperature ILs (RTILs) can be created are presented on Fig. 3 [28].

Most important characteristics of ILs in terms of analytical chemistry is their low vapour pressure, high thermal stability, high

degree of solubility for a wide range of organic and inorganic substance and miscibility in different solvents. Mentioned properties are a result of electrostatic interactions between cations and anions and unique intermolecular interactions [29]. What is very important, there is a possibility to design their physicochemical properties by proper selection of cations and anions, to create an IL that exhibit exceptional selectivity toward a groups of target compounds, becoming task specific solvents.

Due to their properties, ionic liquids have been successfully applied in many analytical chemistry fields like chromatography, capillary electrophoresis, mass spectrometry and of course sample preparation and extraction techniques as an alternative to traditional organic solvents. Considering the specification of each extraction method, the utilization of ILs may be divided in use in solvent-based extraction and sorption-based extraction [29].

Solvent-based extraction methods consist of four main techniques, namely:

- Single Drop Microextraction (SDME)
- Dispersive Liquid-Liquid Microextraction (DLLME)
- Hollow Fibre Liquid Phase Microextraction (HF-LPME)
- Liquid-liquid Extraction (LLE) – Ionic liquids were also utilized as an alternative to the traditional organic solvents in this type of extraction, but in this review only IL-based solvent extraction in the microscale will be discussed.

2.4.1. Ionic liquid based single drop microextraction

SDME is the extraction technique that was first introduced in 1996. The principle of this method is based on the distribution of the target compounds between the sample and a microdrop of the extractant solvent suspended on the tip of the microsyringe. For the

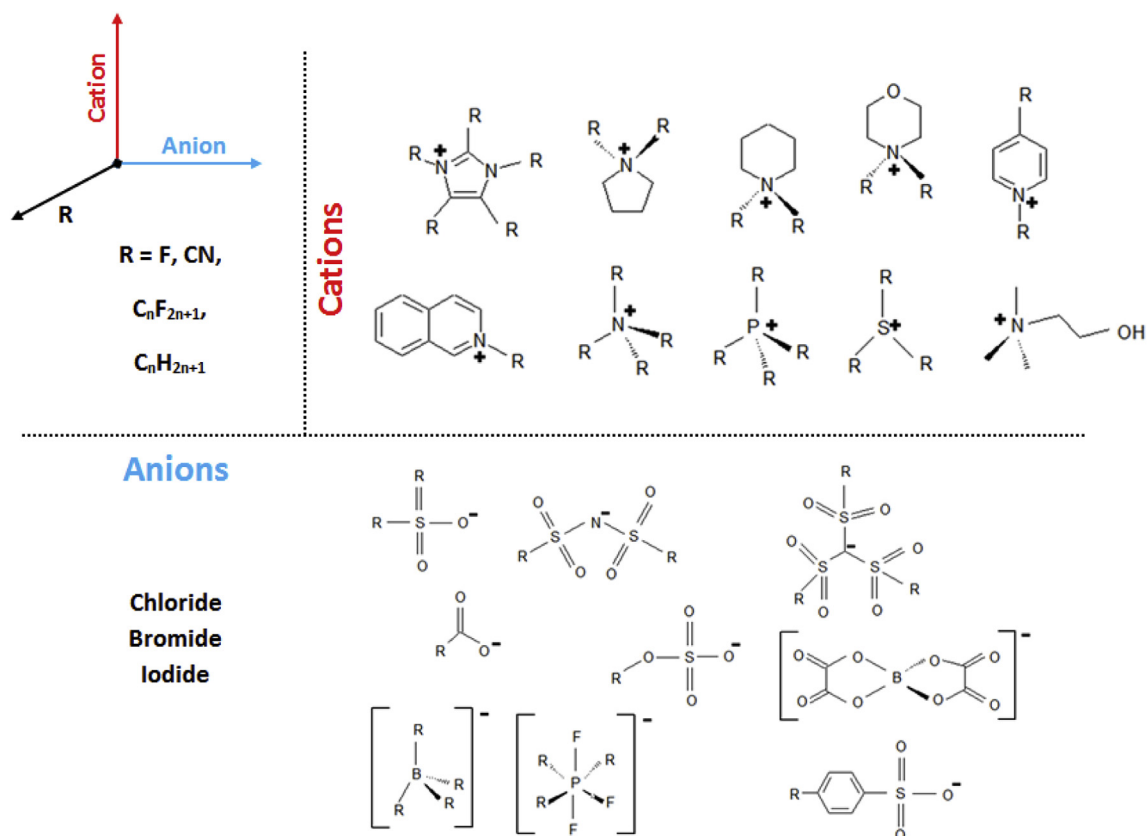

Fig. 3. Most popular cations and anions of functional variations of RTILs.



first time it was applied to extract 4-methylacetophenone with the drop of n-octane [30]. Nowadays SDME technique is widely applied for determination of target analytes in both biological and environmental matrices, using two different modes.

Direct Immersion – SDME is two phase mode, where the drop of the solvent is immersed in the sample solution. Head Space – SDME is a three-phase mode, where the drop of the solvent, suspended on the tip of the needle is immersed in the sample headspace. After appropriate time of equilibration, the drop containing the analytes is withdrawn to the microsyringe and then may be directly analyzed [29,30]. The scheme of each aforementioned SDME systems is shown in Fig. 4.

Single Drop Microextraction is relatively cheap, fast, the volumes of the solvents are very small (few μL), is rapid and easy to operate. Anyhow the use of ionic liquids as an alternative to organic solvents provides more advantages. The bigger the extractant droplet is, the better extraction capability and precision may be gained. Low vapour pressure and high viscosity of ILs result in possibility to obtain big and stable microdroplets [29]. For the first time, ILs were used to perform SDME in 2003 for the extraction of PAHs and since then the IL based SDME has become popular technique. The development of this method may be observed as an increase of the number of scientific papers concerning IL-SDME topic. Recently IL-SDME was also coupled with new detection techniques like tungsten coil electrothermal atomic absorption spectrometry, used in food analysis [31] or for the extraction of target analytes from biological matrices [32]. So far, the type of ionic liquids that are most frequently applied in SDME is PF_6^- -based. More detailed information on application of IL-SDME is given in Table 1.

2.4.2. Dispersive liquid–liquid microextraction

Another widely used sample preparation microextraction technique is DLLME, first reported in 2006. DLLME is simple, rapid and cost-efficient method for the extraction of analytes from aqueous matrices, using water immiscible solvent (extraction solvent) and organic modifier (dispersive solvent), that is miscible both with water and extraction solvent.

Appropriate mixture of both solvents is injected rapidly to the aqueous solution with microsyringe, and the cloudy solution appears. Dispersive solvent aids in formation of very fine droplets of

the extractant in the sample solution. The large surface area between extraction solvent and the aqueous phase result in fast mass transfer, so the analytes are migrating to the extractant droplets in the very short time. After that the extraction solvent is separated, usually by centrifugation [30]. The scheme of the procedure is given in Fig. 5.

Preconcentration factors and method efficiency are high, thus DLLME became popular sample preparation technique that is drawing a lot of attention during the last decade. The main drawback of this technique is that there is only a few efficient dispersing and extracting solvents that meet the requirements (insolubility in water, density higher than water, mutual miscibility). Usually as disperser solvents methanol, ethanol, acetonitrile and acetone are used. Halogenated hydrocarbons are frequently applied as extractants, because of their high density, enabling easy separation of analyte-enriched phase [30,33].

The utilization of ionic liquids in DLLME in temperature controlled mode was first introduced in 2008, to determine organophosphorous pesticides in environmental samples [34]. Employing ILs as extraction solvent result in increasing sensitivity and selectivity of the method. Moreover, the amount of toxic organic solvents is minimized, and high density of IL facilitates its separation from the aqueous sample solution [29]. Recently, IL-DLLME was used in such analytical chemistry fields as food analysis (determination of herbicides in wine [35]), forensic analysis (determination of methamphetamine in urine [36]). This technique is also widely applied for trace-element analysis, like metals in environmental samples [30,33]. More detailed information about aforementioned technique applications is given in Table 1.

2.4.3. Hollow fibre liquid phase microextraction (HF-LPME) and liquid phase microextraction (LPME)

In order to eliminate problems connected to SDME (e.g. instability of the microdrop, droplet loss) in 1999 new extraction method – HF-LPME was introduced to stabilize the extracting phase. This technique is based on the extraction of the analytes from the aqueous sample (donor phase) to the organic solvent (acceptor phase) immobilized inside the lumen of the hollow fibre immersed in the sample. There are two different modes of HF-LPME [37,38]:

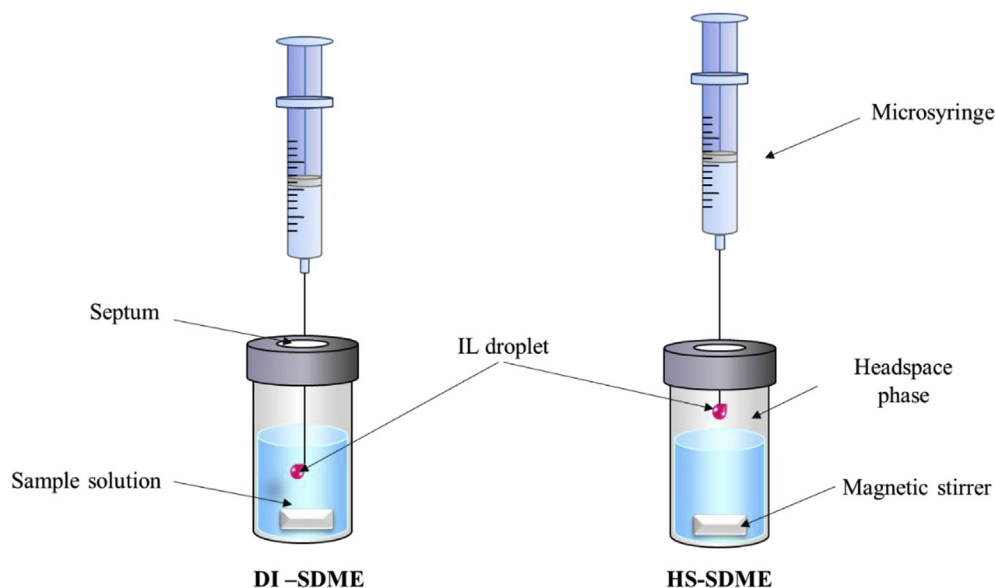

Fig. 4. Schematic representation of two modes of ionic liquid based single drop microextraction – direct immersion mode (on the left) and headspace mode (on the right).

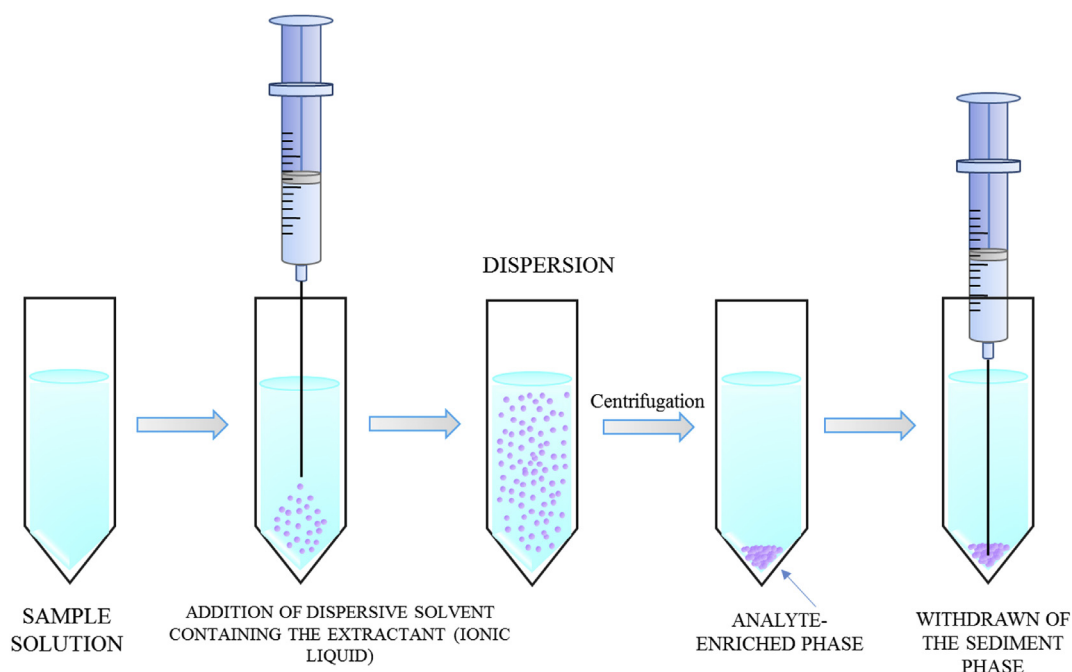

Fig. 5. Schematic representation of the IL-DLLME extraction procedure steps.

- Two phase mode, where the lumen of the hollow fibre is filled with acceptor solvent, the same as the solvent that impregnates porous fibre walls (the same as the membrane phase)
- Three phase mode, where additional solvent, immiscible with acceptor phase is immobilized on the fibre walls.

Sample solution is vigorously stirred during the extraction, and after that the acceptor phase is withdrawn to the microsyringe. The extraction process scheme and setup is depicted in Fig. 6. More detailed description of the method is given in the one of the previous reviews [39]. In both two and three-phase modes the selection of the acceptor phase is crucial for the extraction efficiency. The

requirements that organic solvent must meet are low volatility, immiscibility with sample solution, good mass transfer properties for the analytes. 1-octanol, toluene and n-dodecane are frequently applied as solvents in HF-LPME. The low number of suitable solvents is the one of the limitations of this technique [38].

IL was first applied in HF-LPME in 2007. It was used in three-phase mode for the extraction of chlorophenols from water to impregnate hollow fibre walls. Since then IL-HF-LPME was successfully applied as the extraction and preconcentration method for the analysis of organic compounds, e.g. analysis of phthalate esters in tea beverages [40], sulfonamides in environmental water samples [41]. For the inorganic analysis IL-HF-LPME was for the first

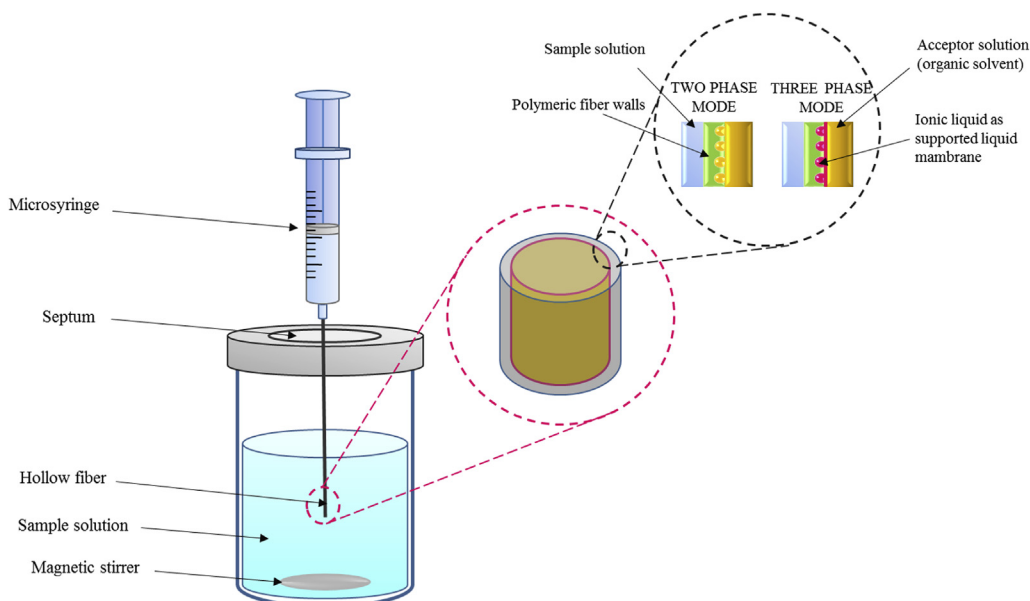

Fig. 6. Scheme of the set-up for IL-HF-LPME technique.

time used in 2010 to determine lead and nickel in the water samples [37]. At present this technique is also used for preconcentration of metals from both environmental and biological samples [37,38]. Detailed information about IL-HF-LPME application is given in Table 1.

Ionic liquids in the sample preparation field are also successfully applied in the case of sorbent-based extraction techniques like solid phase microextraction. Solid phase microextraction (SPME) is based on the partitioning of the analytes between the sample and the stationary phase, followed by desorption of the analytes. Most of the SPME variants are based on the fused silica or metallic fibre, coated with suitable stationary polymeric phase. The coating is the one of most important parameters of SPME, so to enhance selectivity ionic liquids were employed. At the beginning they were used as disposable fibre coatings, but until now the technique development lead to ionic liquid fibres that may be reused many times [42].

Besides many advantages and great perspectives of using ILs in analytical chemistry, the main drawback of these substances as solvent compounds is their high cost and the fact, that the information about their toxicity is still scarce [8].

2.5. Deep eutectic solvents

Deep eutectic solvents (DESs) are environmental friendly, low cost alternative to conventional ionic liquids (ILs) and they are very popular in the scientific and technological sector [43]. DESs are a mixture prepared by complexing an ammonium halide with a hydrogen-bond donor (HBD) such as carboxylic acids, alcohols, range of amides and many more.

The evolution of DESs has a short history. First reports on the creation of DESs dates back to 2001. A few years later first research on the use of liquid solutions with unusual solvent properties in the practice was carried out. Also general formula $R^1R^2R^3R^4N^+X^-Y^-$ to defined DESs was created. According to the used complexing agents, DESs can be classified into three groups [44]:

Type I $Y \rightarrow MCl_x$, $M = Zn, Sn, Fe, Al, Ga$;
 Type II $Y \rightarrow MCl_x \cdot yH_2O$, $M = Cr, Co, Cu, Ni, Fe, Ca, Mg, La$;
 Type III $Y \rightarrow HBDs(RZ)$ with $Z = -CONH_2, -COOH, -OH$.

DESs are liquids at temperatures of 100°C or below and exhibit similar solvent properties to the conventional ILs. The main physicochemical properties of DESs which are responsible for their use as green solvents at room temperature are: freezing points, density, viscosity, polarity, ionic conductivity and acidity/alkalinity.

DESs are characterized by their lower freezing points than the freezing points any of its components. Most of DESs are denser than water and are highly viscous at room temperature also the bulk of

DESs exhibit poor ionic conductivities. Whereas extensive hydrogen bonding makes DESs polar in nature [45].

DESs possess many benefits compared to ILs. In Table 2 literature information on main DESs advantages are listed.

Applications of DESs are growing fast as alternatives in research, industry and new process developments because of their potential as environmentally benign solvents and advantages over traditional ionic liquids. DESs as “green” solvents are one of the most important subjects of the so-called “Green Chemistry” and they play a key role in environmentally friendly analytical techniques especially in sample preparation step. More than 80% of analysis time is spent on sample collection and sample preparation, so sample preparation is a critical part of the analytical process. Very often the sample preparation step is based on the extraction process. For effective extraction in accordance with the principles of Green Chemistry, the right selection of environment friendly green solvent is always a challenging task [52]. Nowadays DESs have attracted a great deal of attention as promising green extraction media. Therefore, DESs are widely used in analytical chemistry and thus the process of extraction or separation. DESs are characterized by high viscosity and they can exist in the solid state at room temperature that is why DESs can be successfully used in extraction process of active compounds from natural products. For example DESs are already used as extraction media for glycerine from biodiesel product mixtures aromatics from naphtha. Information on another application of DESs in extraction process are summarized in Table 1.

Recently, various other applications of DESs have been reported. DESs indicate high solubilities for a wide range of solutes including metal oxides. The dissolution of metal oxides in a eutectic mixture of urea/choline chloride is quantified and plays a key role in few processes such as metal winning, corrosion remediation, and catalyst preparation. Due to solvent properties of DESs which enable them to dissolve metal oxides electro polishing of stainless steel also have been proposed [51]. In addition, DESs have traits that make them perfect choices for use in the preparation of materials of different kinds such as new: zeolitic material [53] and organophosphate material [50]. There were also investigated possible uses of DESs for increasing bioavailability in early drug development such as toxicology [54]. DESs can be also used in biocatalysis [55], pharmaceuticals [56], CO₂ absorption [57] and in many others various chemical and industrial applications.

DESs have a green profile and a good prospect for a wider use in the field of green technologies because of their physical and chemical properties. Therefore still growing number of scientific publications in the literature related to DESs and they obtain much attention by the scientific community.

Natural products are a plentiful and perfect source of DESs components due to their enormous chemical variety, biodegradability, sustainability, and low toxicity profile. Therefore the term natural deep eutectic solvents for these liquids, which

Table 2
The main DESs advantages.

Advantages	Description	References
Good biocompatibility	Using quaternary ammonium salts such as choline chloride (ChCl)	[43]
Non-toxic	There was no toxic effect for the tested DESs on all of the studied bacteria confirming their benign effects on these bacteria.	[43]
Environmental friendly, benign	Solvents classified as minimal or no harm upon ecosystems or the environment.	[46]
Biodegradable	Capable of being decomposed by bacteria or other living organisms.	[46,47]
Simple preparation procedures	The components (HBD, neutral compounds such as sugars and salts) can be easily mixed to obtain target eutectic mixture.	[48]
Nonreactive with water	Adding water to the solvent does not result in chemical reactions.	[47]
Low production cost, easily available components	Low cost of raw materials	[49]
Ionic nature and relatively high polarity	High solubility of many ionic species, such as metal salts.	[50]
Large number of combinations can be produced	Greater designability with a broad selection of cations, anions, HBDs, and salt/HBD molar ratios	[51]



Table 3

Most common methods used for preparing natural deep eutectic solvents in analytical chemistry.

Method	Preparation	References
Heating and stirring	Stir two-component mixture and water and heat in a water bath below 50°C until a clear liquid is formed (30–90 min). Heat the two-component mixture to 80°C with constant stirring until a homogeneous liquid is formed.	[60–63] [51,64]
Vacuum evaporating	Dissolve components in water and evaporate at 50°C with a rotary evaporator. The obtained liquid put in a desiccator with silica gel until constant weight is reached.	[60]
Freeze drying	Mix components. Freeze the obtained aqueous solution and subsequently freeze-dried for the achievement of clear viscous liquids.	[65]

extends the composition of DESs to natural products, such as sugars, alcohols, amino acids, organic acids, and choline derivatives was proposed [58].

2.5.1. Natural deep eutectic solvents (NADES)

Natural deep eutectic solvents (NADES) fully represent green chemistry principles. The NADES are non-toxic, renewable and exceptionally efficient solvents for extraction and separation, especially in analytical chemistry.

The main advantage of NADES is the facility to prepare large number of variants of these solvents (about 10^6) [59]. Table 3 lists literature information on most commonly methods used for preparing NADES. These preparation methods are used in the literature with various modifications about e.g. time of heating or temperature, depending on the nature of the substances which are ingredients for preparing NADES.

NADES could be found in nature, therefore these mixture based on natural compounds, particularly primary metabolites which are naturally present in all types of cells and organisms [60]. The general ingredient of NADES is sugars (glucose, saccharose, fructose, etc.); organic acids (lactic, malic, citric acids, etc.); urea and choline chloride. The interactions nature that take place in the eutectic behaviour depends on the ingredients type where hydrogen bonds or Van der Waals forces are involved. Many publications about different techniques applied for the exploring of the NADES structure occurred. These techniques are: Crystallographic data, Nuclear Magnetic Resonance (NMR) spectroscopy, Fourier Transform Infrared Spectroscopy (FT-IR) and Fast Atom Bombardment-Mass Spectrometry (FAB)-MS [60,61].

NADES can be applied at many stages of the entire chemical process and they can be used in many research fields including analytical chemistry. Due to its specific physicochemical properties (negligible volatility, liquid state below 0°C, adjustable viscosity, sustainability, biodegradability, non toxicity profiles, and high solubilization power of polar and non-polar compounds [59,62]) NADES offer interesting perspectives for sample preparation, including synthesis, dilution, preconcentration and in many cases also extraction. Because NADES are greener and safer alternatives to widely used toxic organic solvents it is not surprising that they have been employed in extraction of many compounds from various matrices. NADES could be used in extraction of valuable secondary metabolites of plants for their direct application in pharmaceutical, cosmetics and food industries [9,66]. The most studied application of NADES is extraction of phenolic compounds. Information on another application of NADES in extraction process is summarized in Table 1.

Another potential applications of NADES are enhancers of supercritical fluid technology [63], in the biomedical field to prepare drug delivery systems, biocatalysis, gas separations, materials science and electrochemistry [59].

2.6. Bio-derived solvents

Bio-derived solvents are a group of solvents that are produced from biomass in a biorefinery [1] and after being used, they can be

biodegraded as presented in Fig. 7A. Biomass includes a wide range of sources such as forest products (e.g. wood), aquatic biomass (e.g. microalgae), energy crops (e.g. corn) and waste materials (e.g. urban wastes). A range of possible solvents that can be derived from bio-resources are presented in Fig. 7B.

Bio-derived solvents are characterized by many advantages for instance low toxicity, environmental benignness and biodegradability. Due to these reasons and because renewable feedstocks are used for production what is among the “Twelve Principles of Green Chemistry”, bio-derived solvents are classified as green solvents [1].

Although, searching for new bio-derived solvents is of great interest in recent years and many of new solvents have been discovered, not all of them can be used in solvent extraction due to some specific requirements for solvents to be used for this application [1].

There are several requirements to use solvents in extraction process carried out in “green” way. Ideally, the solvent needs to have low toxicity, non-flammability, good solute selectivity, inertness to equipment materials, high capacity for desired solute, sufficiently high interfacial tension, reasonable cost and minimal viscosity [1]. In addition, the solvent solubility in water should be sufficiently low in order to minimize solvent losses during extraction. Although, several studies of physicochemical properties of newly derived solvents [67,68] were carried out, they are still some shortcomings in this area. Taking this into account, solvent solubility in water can be used as a prerequisite to evaluate suitability of solvents for solvent extraction applications [1]. Considering these information, the potential to be applied in solvent extraction processes due to insolubility in water have biodiesels, terpenes and 2,5-dimethylfuran (DMF).

The potential bio-derived solvents for solvent extraction are α -Pinene, ν -Limonene, SBME, DMF and *p*-Cymene. This is due to appropriate reasons: i) viscosities of these bio-derived solvents are quite low, making them easy to handle in solvent extraction applications; ii) the densities of these bio-derived solvent are lower than 0.9 g ml^{-1} and higher than 0.8 g ml^{-1} (the density of solvents used in solvent extraction is recommended to be about 0.8 g ml^{-1} to aid phase separations [69]); they all have very low vapour pressure at room temperature, preventing solvent loss by evaporation (except for DMF). It needs to be mentioned that in terms of the risk of fire SBME is the safest solvent due to its high flash point. Despite the fact that all of these bio-derived solvents are good candidates for extraction solvents, however, biodiesels and terpenes have been investigated for suitability in solvent extraction.

It is well known that a wide variety of feedstocks that contain triacylglycerol can be used to produce biodiesel by transesterification. Generally, four categories of feedstocks are applied for biodiesel production namely algae, animal fats, oil seeds and various low-value materials such as used cooking oils [70]. Depending on feedstocks used for biodiesel production, it is characterized by clear differences in carbon chain length and the degree of unsaturation, which are the two influential factors determining physicochemical properties of biodiesels [71]. Biodiesel (Soybean Oil Methyl Esters, SBME) has been tested for suitability as a solvent

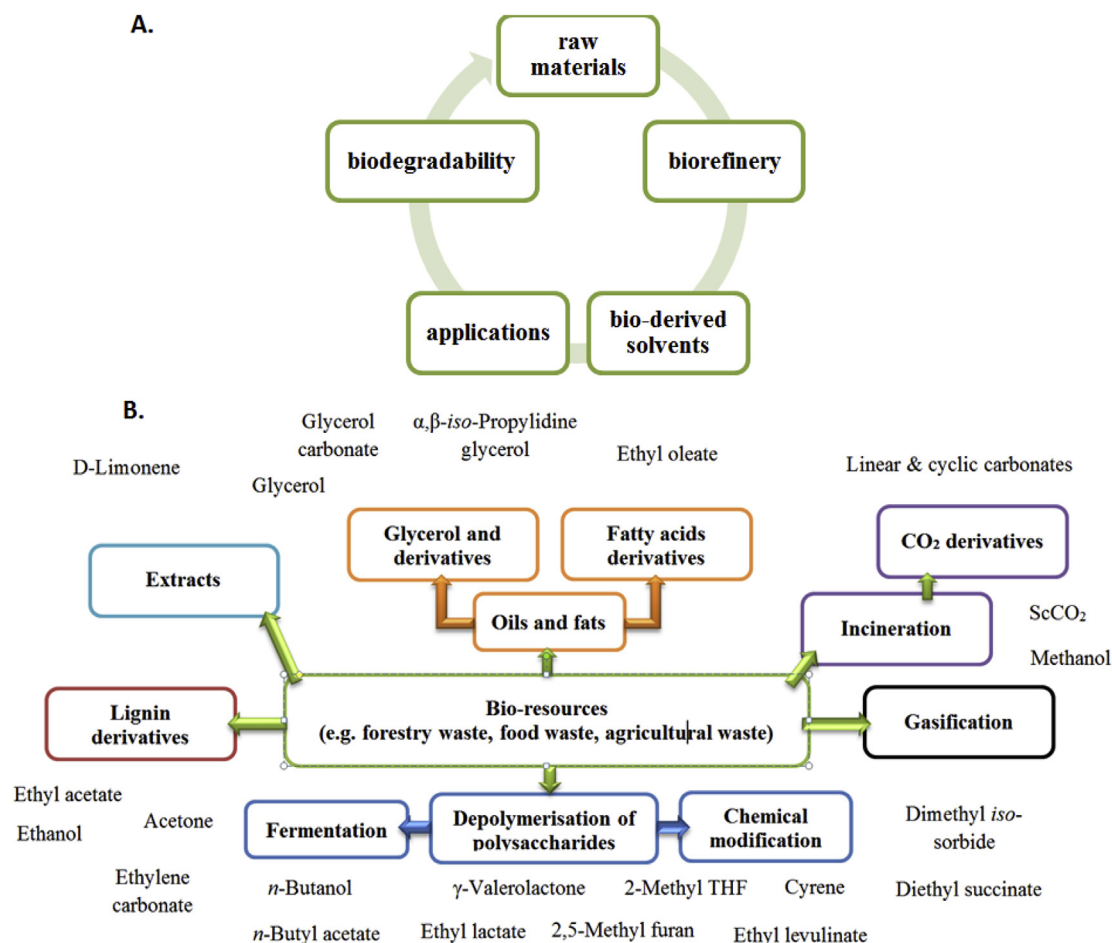

Fig. 7. Life cycle of bio-derived solvents (A) and examples of bio-derived solvents (B).

in extraction of neutral, ionizable and metal solutes from water and its overall performance was similar to traditional VOCs, making it a promising alternative solvent in solvent extraction processes (Table 1).

Terpenes are a class of unsaturated hydrocarbons composed of isoprene C5 units and exist naturally in essential oils and oleoresins of plants such as conifers [1]. The most popular terpenes used as solvents are α -pinene and D-limonene. Because some of physicochemical properties of α -pinene, D-limonene and *p*-cymene are similar to that of hexane, several studies have been performed to explore the possibility of replacing hexane with these renewable solvents. D-Limonene, α -pinene and *p*-cymene have been used in natural products extraction from a variety of feedstocks and were comparable or provided even better results compared with traditional solvents (Table 1).

2.7. Solvents environmental impact assessment

Molecular organic solvents are relatively well described in terms of their impact on environment, compared to ILs, DES or NADES and supercritical fluids. There are several solvent selection guides (SSGs) developed, most of them originating from pharmaceutical industry sector. The assessment criteria in SSGs are related to environmental aspects of solvent application, human health aspects, chemical safety and sometimes solvent potential to be preferentially disposed. As a result each solvent is given a colour label – green, yellow or red accompanied with descriptions, like “recommended”, “to be confirmed”, “problematic” or “hazardous”.

Another SSG [87], was developed in academia was aimed at assessment of 151 solvents, many of them used in analytical laboratories. After grouping these solvents according to their physicochemical parameters with cluster analysis to three groups – polar ones, nonpolar and volatile, nonpolar and rather non-volatile – solvents within each group were ranked with multicriteria decision analysis tool. It should be emphasized that there is a certain degree of disagreement between the results of different SSGs. Generally, solvents applied in extraction, such as methanol, ethanol or water are concerned as green. Less polar solvents, used for analytical extractions, such as dichloromethane, hexane or toluene are assessed to cause problems and finding alternatives is advisable.

Another approach was applied to rank solvents according to their risks related with emissions to the environment [88]. In this case the importance of assessment criteria were proportional to distribution of solvent in the environment after emission. What is interesting, terpenes that are commonly considered as green solvents were critically assessed, mainly due to their high photochemical ozone creation potential.

There is a solvents scoring system that is suitable to compare analytical procedures in terms of solvents consumption and their environmental nuisance [89]. Each solvent is described with numerical score that reflects its total hazards towards the environment. The scores are calculated by summing the hazards reflecting solvent toxicity and multiplying by the sum of hazards referring to exposure data. Calculated scores are easily implemented in assessment of the entire analytical procedures, including extraction and liquid chromatographic separation. The score for each

solvent applied in procedure is multiplied by its volume. In this way, many of the analytical procedures, like those based on gas chromatography and SPME or headspace extraction are getting score equal to zero.

Analytical chemistry requires solvents “greenness” assessment systems to be comprehensive, taking variety of factors into consideration. On the other hand the assessment results should be intuitive, easy to be understood and easily handled [90]. These two

requirements are rather contradictory and analytical chemistry awaits for new, improved assessment procedures. Another aspect that should be addressed is performing full life-cycle assessment of analytical extractions. In this manner extraction media that are different in their nature can be compared i.e. ILs, supercritical fluids or NADES with organic solvents. Another issue, is that for many solvents, especially neoteric, ecotoxicological data are very scarce.

Table 4

Information on advantages and drawbacks of selected green extraction solvents.

Advantages	Drawbacks
<p>Ionic liquids Physicochemical characteristics (low vapour pressure, thermal stability etc.) that are connected with low environmental nuisance; Almost unlimited capability in designing properties like polarity, miscibility with water/ organic phase by proper cation/anion selection providing high extraction selectivity and sensitivity towards target analytes A huge number of possible cation/anion configurations A possibility to overcome limitations of some extraction techniques: <ul style="list-style-type: none"> • SDME – using ILs provides better stability of the drop and allows increasing the droplet volume • DLLME – high density of ILs facilitates phase separation • HF-LPME – application of ILs overcomes the problem of limited number of suitable solvents • SPME – using ILs as fibre coating in SPME techniques significantly increases the selectivity towards selected groups of analytes </p>	<p>Relatively high cost Synthesis of most ionic liquids requires a big amount of energy, organic solvents and salts, so they cannot be considered as completely “green” Limited information about toxicity of ionic liquids – some types of ILs (e.g. imidazolium-based) are proven to be hazardous for aquatic environment Low biodegradability In most cases high viscosity and nonvolatility is the limitation in direct coupling the IL-based extract to GC system</p>
<p>Surface active agents Capacity of micellar phase to solubilize species of different nature Low cost Techniques based on using surfactants are usually simple, easy to handle and relatively time-saving Low toxicity Surfactants use in extraction techniques provides good preconcentration factors, high recoveries and selectivity Easy phase separation step by using the temperature or centrifugation Relatively wide range of polar and nonpolar compounds that may be extracted by micellar extraction</p>	<p>The extracts containing surfactant-rich phase need further treatment before introducing to the final determination system like GC or LC Optimisation of the extraction procedure is very important step Commercially available non-ionic surfactants have very complex formulas that may cause detection problems In the case of extraction of the thermally labile compounds the extraction efficiency may be insufficient Difficult to automate</p>
<p>Superheated water Water is probably the cheapest and least-harmful solvent Unique physicochemical properties in subcritical state (lower polarity, decreased permittivity, surface tension and dielectric constant) SHWE is fast, environmentally friendly and selective alternative to traditional solvent extraction for polar and medium polar analytes</p>	<p>Separation of the analytes from the aqueous phase may be problematic A lot of energy is needed to carry out water to subcritical state In practice SHW is usually used for obtaining extracts from natural matrices (plants, fruits) and some environmental pollutants from solid samples</p>
<p>Supercritical fluids Unique physicochemical properties placed between the liquid and gas Better mass transport resulting from lower viscosity Fast extraction No toxic residues and possibility to recycle the supercritical solvent Good extraction efficiency Possibility to direct coupling SFE with instrumental techniques (GC, LC)</p>	<p>Usually the use of organic co-solvent is needed Relatively high cost technique Modelling is inaccurate High energetic demands to obtain critical point</p>
<p>DES Good bio-compatibility. Non-toxic. Environmentally friendly, benign. Biodegradable. Simple preparation procedures. Nonreactive with water. Low production cost, easily available components. Ionic nature and relatively high polarity. Large number of combinations can be produced.</p>	<p>The inherent high viscosity, which results in a slow mass transfer and hampers the efficiency.</p>
<p>NADES Tuneability. The selectivity of NADES for a target compound can be tailored by changing its components. Unique physicochemical properties, with the possibility for their design for particular purposes. Non-flammability. The facility to prepare large number of variants of these solvents. Non-toxic. Biodegradable. High solubilization power of polar and non-polar compound.</p>	<p>High viscosities that not only hinders the mass transport from matrices to solution but also leads to handling difficulties (e.g. in filtration, decantation, and dissolution).</p>
<p>Bio-derived solvents Low toxicity. Environmentally benign. Biodegradable. Renewable resource.</p>	<p>Research is still necessary. Small group of bio-derived solvents that meet the requirements to be used in extraction process.</p>



3. Conclusions

Due to the low levels of the content of analytes in samples, it is necessary to use the separation and enrichment stage before the analysis of appropriately prepared samples. On the other hand, in accordance with current trends, the analytical procedures should aim at the miniaturisation and simplification of the sample preparation step and use environmental friendly solvents. To reduce the intensity of anthropogenic activities related to analytical laboratories, more emphasis is placed on compliance with Green Chemistry principles. Without any doubt, replacement of VOCs by more environmentally sustainable solvents is becoming increasingly important due to the increasing health and environmental concerns as well as economic pressures associated with VOCs. Developing new, eco-friendly and benign solvents which would meet technological and economic demands is perhaps the most popular aspects of Green Chemistry. In this sense, several solvents have been developed and introduced in analytical practice, also in sample preparation process. These solvents were found to be greener and cleaner alternatives to conventional molecular solvents. Such solvents as ionic liquids, superheated water, supercritical fluids, surfactants, bio-derived solvents and deep eutectic solvents are more or less applied in extraction process. This is due to their physicochemical properties which bring advantages in extraction process. These advantages as well as drawback are described in Table 4. Some of these solvents including ILs, supercritical fluids or superheated water are well understood, however, they are still some aspects that need further studies. In the case of bio-derived solvents, DES and NADES, studies are still limited and many unknowns exist. That is why there is a continuous need for research in this area. Moreover, searching for more potential solvents with diversity in physicochemical properties that are required by selectivity of solvent extraction needs to continue while also examining existing solvents. However, the huge potential of described here solvents mainly NADES, and bio-derived solvents, opens interesting perspectives for further research and industrial applications.

References

- [1] Z. Li, K.H. Smith, G.W. Stevens, The use of environmentally sustainable bio-derived solvents in solvent extraction applications—a review, *Chin. J. Chem. Eng.* 24 (2016) 215–220.
- [2] A. Gatuszka, Z. Migaszewski, J. Namieśnik, The 12 principles of green analytical chemistry and the significance mnemonic of green analytical practices, *TrAC* 50 (2013) 78–84.
- [3] C. Capello, U. Fischer, K. Hungerbühler, What is a green solvent? A comprehensive framework for the environmental assessment of solvents, *Green Chem.* 9 (2007) 927–934.
- [4] S.B. Hawthorne, Y. Yang, D.J. Miller, Extraction of organic pollutants from environmental solids with sub- and supercritical water, *Anal. Chem.* 66 (1994) 2912–2920.
- [5] C.C. Teo, S.N. Tan, J.W.H. Yong, C.S. Hew, E.S. Ong, Pressurized hot water extraction (PHWE), *J. Chromatogr. A* 1217 (2010) 2484.
- [6] M. Herrero, M. Castro-Puyana, J.A. Mendiola, E. Ibañez, Compressed fluids for the extraction of bioactive compounds, *TrAC* 43 (2013) 67–83.
- [7] M. Herrero, J.A. Mendiola, A. Cifuentes, E. Ibañez, Supercritical fluid extraction: recent advances and applications, *J. Chromatogr. A* 1217 (2010) 2495–2511.
- [8] B. Kudlak, K. Owczarek, J. Namieśnik, Selected issues related to the toxicity of ionic liquids and deep eutectic solvents – a review, *Environ. Sci. Pollut. Res.* 22 (2015) 11975–11992.
- [9] Y.H. Choi, J. van Spronsen, Y.T. Dai, M. Verberne, F. Hollmann, I. Arends, G.J. Witkamp, R. Verpoorte, Are natural deep eutectic solvents the missing link in understanding cellular metabolism and physiology? *Plant Physiol.* 156 (2011) 1701–1705.
- [10] E. Paleologos, D. Giokas, M. Karayannis, Micelle-mediated separation and cloud-point extraction, *TrAC* 24 (2005) 426–436.
- [11] Z. Ferrera, C. Padron Sanz, C. Mahugo Santana, J. Santana Rodriguez, The use of micellar systems in the extraction and pre-concentration of organic pollutants in environmental samples, *TrAC* 23 (2004) 469–479.
- [12] C. Padron Sanz, R. Halko, S. Sosa Ferrera, J.J. Santana Rodriguez, Micellar extraction of organophosphorus pesticides and their determination by liquid chromatography, *Anal. Chim. Acta* 524 (2004) 265–270.
- [13] A. Hernandez-Martinez, C. Padron Sanz, Determination of Ni, Cr, Cu, Pb and Cd on the Mediterranean endemic plant *Posidonia oceanica* using the green extraction method “microwave assisted micellar extraction” and GFAAS, *Anal. Methods* 5 (2013) 6473–6479.
- [14] B. Froschl, G. Stangl, R. Niesser, Combination of micellar extraction and GC-ECD for the determination of polychlorinated biphenyls (PCBs) in water, *Fresenius J. Anal. Chem.* 357 (1997) 743–746.
- [15] M. Roosta, M. Ghaedi, A. Daneshfar, Optimisation of ultrasound-assisted reverse micelles dispersive liquid-liquid microextraction by Box-Behnken design for determination of acetoin in butter followed by high performance liquid chromatography, *Food Chem.* 161 (2014) 120–126.
- [16] A. Ballesteros-Gómez, M.D. Sicilia, S. Rubio, Supramolecular solvents in the extraction of organic compounds. A review, *Anal. Chim. Acta* 677 (2010) 108–130.
- [17] M. Herrero, A. Cifuentes, E. Ibañez, Sub- and supercritical fluid extraction of functional ingredients from different natural sources: plants, food-by-products, algae and microalgae. A review, *Food Chem.* 98 (2006) 136–148.
- [18] C.G. Pereira, M.A.M. Meireles, Supercritical fluid extraction of bioactive compounds: fundamentals, applications and economic perspectives, *Food Bioprocess. Technol.* 3 (2010) 340–372.
- [19] F. Sahena, I.S.M. Zaidul, S. Jinap, A.A. Karim, K.A. Abbas, N.A.N. Norulaini, A.K.M. Omar, Application of supercritical CO₂ in lipid extraction – a review, *J. Food Eng.* 95 (2009) 240–253.
- [20] R. Mohamed, M. Saldana, P. Mazzafera, Extraction of caffeine, theobromine, cocoa butter from Brazilian cocoa beans using supercritical CO₂ and ethane, *Ind. Eng. Chem. Res.* 41 (2002) 6751–6758.
- [21] O. Catchpole, J. Grey, N.B. Perry, E.J. Burgess, W. Redmont, N. Porter, Extraction of chilli, black pepper and ginger with near-critical CO₂, propane and dimethyl ether. Analysis of extracts by quantitative nuclear magnetic resonance, *J. Agric. Food Chem.* 51 (2003) 4853–4860.
- [22] M. Sun, F. Temelli, Supercritical carbon extraction of carotenoids from carrot using canola oil as a continuous co-solvent, *J. Supercrit. Fluids* 37 (2006) 397–408.
- [23] M.A. Shabkhiz, M.H. Eikani, Z. Bashiri Sadr, F. Golmohammad, Superheated water extraction of glycyrrhizic acid from licorice root, *Food Chem.* 210 (2016) 396–401.
- [24] N. Rahimi, M. Shiva, S. Ali Mortazavi, A. Hossein Elhamirad, A. Majid Maskooki, G. Rajabzadeh, Kinetic study of superheated water extraction of berberine from *Berberis vulgaris* root, *Bulg. Chem. Commun.* 47 (Special Issue D) (2015) 140–146.
- [25] T. Hyotylainen, T. Andersson, K. Hartonen, K. Kuosmanen, M.-L. Riekkola, Pressurized hot water extraction coupled on-line with LC-GC: determination of polyaromatic hydrocarbons in sediment, *Anal. Chem.* 72 (2000) 3070–3076.
- [26] A.E. McGowin, K.K. Adom, A. Obubuafo, Screening of compost for PAHs and pesticides using static subcritical water extraction, *Chemosphere* 45 (2001) 857–864.
- [27] B. van Bavel, K. Hartonen, C. Rappe, M.-L. Riekkola, *Analyst* 124 (1999) 1351.
- [28] R.L. Vekariya, A review of ionic liquids: applications towards catalytic organic transformations, *J. Mol. Liq.* 227 (2017) 44–60.
- [29] T.D. Ho, C. Zhang, L.W. Hantao, J.L. Anderson, Ionic liquids in analytical chemistry: fundamentals, advances and perspectives, *Anal. Chem.* 86 (2014) 262–285.
- [30] E. Stanisz, J. Werner, A. Zgoła-Grzeškowiak, Liquid-phase microextraction techniques based on ionic liquids for preconcentration and determination of metals, *TrAC* 61 (2014) 54–66.
- [31] C. Jiang, S. Wei, X. Li, Y. Zhao, M. Shao, H. Zhang, A. Yu, Ultrasonic nebulization headspace ionic liquid-based single drop microextraction of flavour compounds in fruit juices, *Talanta* 106 (2013) 237–247.
- [32] L. Vidal, A. Chisvert, A. Canals, A. Salvador, Sensitive determination of free benzophenone-3 in human urine samples based on an ionic liquid as extractant phase in single-drop microextraction prior to liquid chromatography analysis, *J. Chromatogr. A* 1174 (2007) 95–103.
- [33] E.M. Martinis, P. Berton, R.G. Wuilloud, Ionic liquid-based microextraction techniques for trace-element analysis, *TrAC* 60 (2014) 54–70.
- [34] Q. Zhou, H. Bai, C. Xie, J. Xiao, Trace determination of organophosphorus pesticides in environmental samples by temperature-controlled ionic liquid dispersive liquid-liquid microextraction, *J. Chromatogr. A* 1188 (2008) 148–153.
- [35] A. Gure, F.J. Lara, A.M. Garcia-Campana, N. Megersa, M. Del Olmo-Iurela, Vortex-assisted ionic liquid dispersive liquid-liquid microextraction for the determination of sulfonylurea herbicides in wine samples by capillary high-performance liquid chromatography, *Food Chem.* 170 (2015) 348–353.
- [36] R. Weng, X. Qi, L. Zhao, S. Liu, S. Gao, X. Ma, Y. Deng, Ionic-liquid-based dispersive liquid-liquid microextraction coupled with high-performance liquid chromatography for the forensic determination of methamphetamine in human urine, *J. Sep. Sci.* 39 (2016) 2444–2450.
- [37] J. Abulhassani, J.L. Manzoori, M. Amjadi, Hollow fiber based-liquid phase microextraction using ionic liquid solvent for preconcentration of lead and nickel from environmental and biological samples prior to determination by electrothermal atomic absorption spectrometry, *J. Hazard. Mater.* 176 (2010) 481–486.
- [38] H. Chen, J. Han, Y. Wang, Y. Hu, L. Ni, Y. Liu, W. Kang, Y. Liu, Hollow fiber liquid-phase microextraction of cadmium(II) using an ionic as the extractant, *Microchim. Acta* 181 (2014) 1455–1461.

- [39] J. Plotka-Wasyłka, K. Owczarek, J. Namieśnik, Modern solutions in the field of microextraction using liquid as a medium of extraction, *TrAC* 85 (2016) 46–64.
- [40] J. Wang, S. Huang, P. Wang, Yang, Method development for the analysis of phthalate esters in tea beverages by ionic liquid hollow fibre liquid-phase microextraction and liquid chromatographic detection, *Food Control* 67 (2016) 278–284.
- [41] Y. Tao, J.-F. Liu, X.-L. Hu, H.-C. Li, T. Wang, G.-B. Jiang, Hollow fiber supported ionic liquid membrane microextraction for determination of sulfonamides in environmental water samples by high-performance liquid chromatography, *J. Chromatogr. A* 1216 (2015) 6259–6266.
- [42] T.D. Ho, A. Canestraro, J. Anderson, Ionic liquids in solid-phase microextraction: a review, *Anal. Chim. Acta* 695 (2011) 18–43.
- [43] M. Hayyan, M.A. Hashim, A. Hayyan, M.A. Al-Saadi, I.M. AlNashef, M.E.S. Mirghani, O.K. Saheed, Are deep eutectic solvents benign or toxic? *Chemosphere* 90 (2013) 2193–2195.
- [44] Y. Zhang, X. Ji, X. Lu, Choline-based deep eutectic solvents for mitigating carbon dioxide emissions, in: B. Morreale, F. Shi (Editors), *Novel Materials for Carbon Dioxide Mitigation Technology*, Elsevier, Pittsburgh, USA, 2015, pp. 87–115.
- [45] S. Khandelwal, Y. Kumar Tailor, M. Kumar, Deep eutectic solvents (DESS) as eco-friendly and sustainable solvent/catalyst systems in organic transformations, *J. Mol. Liq.* 215 (2016) 345–386.
- [46] S.-H. Wu, A.R. Caparanga, R.B. Leron, M.-H. Li, Vapor pressure of aqueous choline chloride-based deep eutectic solvents (ethaline, glyceline, maline and reline) at 30–70°C, *Thermochim. Acta* 544 (2012) 1–5.
- [47] A.P. Abbott, D. Boothby, G. Capper, D.L. Davies, R.K. Rasheed, Deep eutectic solvents formed between choline chloride and carboxylic acids: versatile alternatives to ionic liquids, *J. Am. Chem. Soc.* 126 (2004) 9142–9147.
- [48] H.-R. Jhong, D. Shan-Hill Wong, C.-C. Wan, Y.-Y. Wang, T.-C. Wei, A novel deep eutectic solvent-based ionic liquid used as electrolyte for dye-sensitized solar cells, *Electrochem. Commun.* 11 (2009) 209–221.
- [49] L. Liu, Y. Kong, H. Xu, J.P. Li, J.X. Dong, Z. Lin, Ionothermal synthesis of a three-dimensional zinc phosphate with DFT topology using unstable deep-eutectic solvent as template-delivery agent, *Micropor. Mesopor. Mater.* 115 (2008) 624–628.
- [50] E.R. Parnham, E.A. Drylie, P.S. Wheatley, A.M.Z. Slawin, R.E. Morris, Ionothermal materials synthesis using unstable deep-eutectic solvents as template-delivery agents, *Angew. Chem.* 118 (2006) 5084–5088.
- [51] A.P. Abbott, G. Capper, D.L. Davies, R.K. Rasheed, V. Tambyrajah, Novel solvent properties of choline chloride/urea mixtures, *Chem. Commun.* (2003) 70–71.
- [52] M. Balal Arain, E. Yilmaz, M. Soylak, Deep eutectic solvent based ultrasonic assisted liquid phase microextraction for the FAAS determination of cobalt, *J. Mol. Liq.* 224 (2016) 538–543.
- [53] E.R. Cooper, C.D. Andrews, P.S. Wheatley, P.B. Webb, P. Wormald, R.E. Morris, Ionic liquids and eutectic mixtures as solvent and template in synthesis of zeolite analogues, *Nature* 430 (2004) 1012–1016.
- [54] H.G. Morrison, C.C. Sun, S. Neervannan, One-pot-nucleophilic fluorination of acetophenones in a deep eutectic solvent, *Int. J. Pharm.* 378 (2009) 136–139.
- [55] D. Lindberg, M.D. Revenga, M. Widersten, Deep eutectic solvents (DESS) are viable cosolvents for enzyme-catalyzed epoxide hydrolysis, *J. Biotechnol.* 147 (2010) 169–171.
- [56] G. Morrison, C.C. Sun, S. Neervannan, Characterization of thermal behavior of deep eutectic solvents and their potential as drug solubilization vehicles, *Int. J. Pharm.* 378 (2009) 136–139.
- [57] W.C. Su, D.S.H. Wong, M.H. Li, Effect of water on solubility of carbon dioxide in (aminomethanamide + 2-hydroxy-n,n,n-trimethylethanaminium chloride), *J. Chem. Eng. Data* 54 (2009) 1951–1955.
- [58] Y. Dai, J. van Spronsen, G.-J. Witkamp, R. Verpoorte, Y. Hae Choi, Ionic liquids and deep eutectic solvents in natural products research: mixtures of solids as extraction solvents, *J. Nat. Prod.* 76 (2013) 2162–2173.
- [59] K. Owczarek, N. Szczepańska, J. Plotka-Wasyłka, M. Rutkowska, O. Shyshchak, M. Bratychak, J. Namieśnik, Natural deep eutectic solvents in extraction process, *Ch&ChT* 10 (2016) 601–606.
- [60] Y. Dai, J. van Spronsen, G.J. Witkamp, R. Verpoorte, Y.H. Choi, Natural deep eutectic solvents as new potential media for green technology, *Anal. Chim. Acta* 766 (2013) 61–68.
- [61] Y. Dai, G.J. Witkamp, R. Verpoorte, Y.H. Choi, Tailoring properties of natural deep eutectic solvents with water to facilitate their applications, *Food Chem.* 187 (2015) 14–19.
- [62] Y. Dai, R. Verpoorte, Y.H. Choi, Natural deep eutectic solvents providing enhanced stability of natural colorants from safflower (*Carthamus tinctorius*), *Food Chem.* 159 (2014) 116–121.
- [63] M. Martins, I.M. Aroso, R.L. Reis, A.R.C. Duarte, R. Craveiro, A. Paiva, Enhanced performance of supercritical fluid foaming of natural-based polymers by deep eutectic solvents, *AIChE J.* 60 (2014) 3701–3706.
- [64] Z. Wei, X. Qi, T. Li, M. Luo, W. Wang, Y. Zu, et al., Application of natural deep eutectic solvents for extraction and determination of phenolics in *Cajanus cajan* leaves by ultra-performance liquid chromatography, *Sep. Purif. Technol.* 149 (2015) 237–244.
- [65] M.C. Gutierrez, M.L. Ferrer, C.R. Mateo, F.D. Monte, Freeze-drying of aqueous solutions of deep eutectic solvents: a suitable approach to deep eutectic suspensions of self-assembled structures, *Langmuir* 25 (2009) 5509–5515.
- [66] M. Cvjetko Bubalo, S. Vidović, I. Radojčić Redovniković, S. Jokić, Green solvents for green technologies, *J. Chem. Technol. Biotechnol.* 90 (2015) 1631–1639.
- [67] L. Lomba, B. Giner, I. Bandres, C. Lafuente, M.A.R. Pino, Physicochemical properties of green solvents derived from biomass, *Green Chem.* 13 (8) (2011) 2062–2070.
- [68] J.I. Garcia, H. Garcia-Marin, J.A. Mayoral, P. Perez, Green solvents from glycerol. Synthesis and physico-chemical properties of alkyl glycerol ethers, *Green Chem.* 12 (3) (2010) 426–434.
- [69] D.S. Flett, J. Melling, M. Cox, *Commercial Solvent Systems for Inorganic Processes*, Handbook of Solvent Extraction, John Wiley & Sons, New York; Chichester; Brisbane; Toronto; Singapore, 1983, pp. 629–647.
- [70] B. Moser, *Biodiesel production, properties, and feedstocks*, in: D. Tomes, P. Lakshmanan, D. Songstad (Editors), *Biofuels*, Springer, New York, 2011, pp. 285–347.
- [71] S.K. Hoekman, A. Broch, C. Robbins, E. Cenicerros, M. Natarajan, Review of biodiesel composition, properties, and specifications, *Renew. Sust. Energ. Rev.* 16 (2012) 143–169.
- [72] M. Made, Z.-Q. Tan, R. Liu, J.-F. Liu, Nanofluid of zinc oxide nanoparticles in ionic liquid for single drop liquid microextraction of fungicides in environmental waters prior to high performance liquid chromatographic analysis, *J. Chromatogr. A* 1395 (2015) 7–15.
- [73] G. Ren, Q. Huang, J. Wu, J. Yuan, G. Yang, Z. Yan, Cloud point extraction-HPLC method for the determination and pharmacokinetic study of aristolochic acids in rat plasma after oral administration of *Aristolochia fructus*, *J. Chromatogr. B* 953–954 (2014) 73–79.
- [74] H. Wang, J. Ding, L. Ding, N. Ren, Analysis of sulfonamides in soil, sediment and sludge based on dynamic microwave-assisted micellar extraction, *Environ. Sci. Pollut. Res.* 23 (2016) 12954–12965.
- [75] S. Montesdeoca-Esponda, Cristina Mahugo-Santana, Z. Sosa-Ferrera, J.J. Santana-Rodriguez, A dispersive liquid–liquid micellar microextraction for the determination of pharmaceutical compounds in wastewaters using ultra-high-performance liquid chromatography with DAD detection, *Biomed. Chromatogr.* 29 (2015) 353–356.
- [76] J.P. Maran, S. Manikandan, Modeling and optimization of supercritical fluid extraction of anthocyanin and phenolic compounds from *Syzygium cumini* fruit pulp, *J. Food Sci. Technol.* 51 (2014) 1938.
- [77] C. Da Porto, A. Natolino, D. Decorti, Extraction of proanthocyanidins from grape marc by supercritical fluid extraction using CO₂ as solvent and ethanol–water mixture as co-solvent, *J. Supercrit. Fluids* 87 (2014) 59–64.
- [78] M. Solana, C.S. Rizza, A. Betucco, Exploiting microalgae as a source of essential fatty acids by supercritical fluid extraction of lipids: comparison between *Scenedesmus obliquus*, *Chlorella protothecoides* and *Nannochloropsis salina*, *J. Supercrit. Fluids* 92 (2014) 311–318.
- [79] X.-L. Qi, X. Peng, Y.-Y. Huang, L. Li, Z.-F. Wei, Y.-G. Zu, Y.-J. Fu, Green and efficient extraction of bioactive flavonoids from *Equisetum palustre* L. by deep eutectic solvents-based negative pressure cavitation method combined with macroporous resin enrichment, *Ind. Crops Prod.* 70 (2015) 142–148.
- [80] J.M. Matong, L. Nyaba, P.N. Nomngongo, Determination of As, Cr, Mo, Sb, Se and V in agricultural soil samples by inductively coupled plasma optical emission spectrometry after simple and rapid solvent extraction using choline chloride-oxalic acid deep eutectic solvent, *Ecotoxicol. Environ. Saf.* 135 (2017) 152–157.
- [81] H. Lores, V. Romero, I. Costas, C. Bendicho, I. Lavilla, Natural deep eutectic solvents in combination with ultrasonic energy as a green approach for solubilisation of proteins: application to gluten determination by immunoassay, *Talanta* 162 (2017) 453–459.
- [82] C. Bakirtzi, K. Triantafyllidou, D.P. Makris, Novel lactic acid-based natural deep eutectic solvents: efficiency in the ultrasound-assisted extraction of antioxidant polyphenols from common native Greek medicinal plants, *J. Appl. Res. Med. Aromat. Plants* 3 (2016) 120–127.
- [83] Y. Liu, J. Garzon, J. Brent Friesen, Y. Zhang, J.B. McAlpine, D.C. Lankin, S.-N. Chen, G.F. Pauli, Countercurrent assisted quantitative recovery of metabolites from plant-associated natural deep eutectic solvents, *Fitoterapia* 112 (2016) 30–37.
- [84] Javed Iqbal, Chandra Theegala, Microwave assisted lipid extraction from microalgae using biodiesel as co-solvent, *Algal Res.* 2 (2013) 34–42.
- [85] W. Wang, H. Yang, Y. Liu, H. Cui, J. Chen, The application of biodiesel and secocetylphenoxycetic acid (CA-12) for the yttrium separation, *Hydrometallurgy* 109 (1–2) (2011) 47–53.
- [86] M.T. Golmakani, J.A. Mendiola, K. Rezaei, E. Ibáñez, Pressurized limonene as an alternative bio-solvent for the extraction of lipids from marine microorganisms, *J. Supercrit. Fluids* 92 (2014) 1–7.
- [87] M. Tobiszewski, S. Tsakovski, V. Simeonov, J. Namieśnik, F. Pena-Pereira, A solvent selection guide based on chemometrics and multicriteria decision analysis, *Green Chem.* 17 (2015) 4773–4785.
- [88] M. Tobiszewski, J. Namieśnik, F. Pena-Pereira, Environmental risk-based ranking of solvents using the combination of a multimedia model and multicriteria decision analysis, *Green Chem.* 19 (2017) 1034–1042.
- [89] M. Tobiszewski, J. Namieśnik, Scoring of solvents used in analytical laboratories by their toxicological and exposure hazards, *Ecotoxicol. Environ. Saf.* 120 (2015) 169–173.
- [90] M. Tobiszewski, Metrics for green analytical chemistry, *Anal. Methods* 8 (2016) 2993–2999.

