

OPEN ACCESS

Gas sampling system for matrix of semiconductor gas sensors

To cite this article: Grzegorz Jasinski *et al* 2016 *IOP Conf. Ser.: Mater. Sci. Eng.* **104** 012033

View the [article online](#) for updates and enhancements.

You may also like

- [Shaping Place Identity through Interaction on the Example of the European Solidarity Centre in Gdansk](#)
Wojciech Targowski and Czy Piotr
- [Museum Institutions in Monuments - Positive and Negative Aspects of Adaptation: The New Amber Museum and Museum of Science in Gdansk, Poland](#)
Ksenia Piatkowska
- [Analysis and Risk Evaluation on the Case of Alteration, Revitalization and Conversion of a Historic Building in Gdask](#)
Beata Grzyl, Adam Kristowski and Emilia Miszewska-Urbaska

PRIME
PACIFIC RIM MEETING
ON ELECTROCHEMICAL
AND SOLID STATE SCIENCE

HONOLULU, HI
Oct 6-11, 2024

Abstract submission deadline:
April 12, 2024

Learn more and submit!

Joint Meeting of
The Electrochemical Society
·
The Electrochemical Society of Japan
·
Korea Electrochemical Society

Gas sampling system for matrix of semiconductor gas sensors

Grzegorz Jasinski¹, Anna Strzelczyk², Piotr Kosciński¹

¹ Faculty of Electronics, Telecommunication and Informatics,
Gdansk University of Technology, Narutowicza 11/12, 80-233 Gdansk, Poland

² Faculty of Chemistry, Gdansk University of Technology,
Narutowicza 11/12, 80-233 Gdansk, Poland

E-mail: grzegorz.jasinski@eti.pg.gda.pl

Abstract. Semiconductor gas sensors are popular commercial sensors applied in numerous gas detection systems. They are reliable, small, rugged and inexpensive. However, there are a few problem limiting the wider use of such sensors. Semiconductor gas sensor usually exhibits a low selectivity, low repeatability, drift of response, strong temperature and moisture influence on sensor properties. Sample flow rate is one of the parameters that influence sensors response what should be considered in the measurement system. This paper describes low cost module for controlling measured gas flow rate. The proposed equipment will be used as a component of electronic nose system employed for classifying and distinguishing different levels of contamination in air.

1. Introduction

In recent years, gas sensors are used in more and more applications. Gas sensors, which are commercially available or under development, have a lot of merits, such as rapid detection speed, high sensitivity and durability [1]. What is the most important, they are very inexpensive. However, there are a few problems limiting the wider use of such sensors. Semiconductor gas sensors usually exhibit a low selectivity, low repeatability, drift of a response and strong temperature and moisture influence on sensor properties [2, 3]. Some shortcomings can be minimized to some extent by using an array of sensors and by adopting some pattern recognition techniques [4]. Still overcoming all the problems is difficult.

One of the problems that have to be taken into account is sample flow rate that influence sensors response. The easiest solution, usually chosen in the measurement systems, is to stabilize gas flow rate over gas sensor at desired level. In laboratory condition a mass flow controllers along with some air pumps are commonly used for this purpose. Due to large size and high price such solution is not convenient.

In this paper we propose electronic module for sampling gas into measuring cell under controlled gas flow rate. The module is simple and inexpensive. Emphasis has been placed on universality and modularity. This module can be easily incorporated into system that measures response of a gas sensors matrix. The developed equipment will be used as a component of electronic nose system employed for classifying and distinguishing different levels of contamination in air. The system was prepared for semiconducting gas sensors, but it can be used with any kind of a gas concentration



measuring equipment. To our best knowledge, a similar system has not yet been proposed and examined.

2. Effect of air flow rate on sensor response

There is a lot of research on different sensor constructions working based on various concepts [5]. Influence of gas flow-rate is, however, unusually neglected. There are only few studies investigating this effect [6], thus it is worth to determine relation between gas flow speed and response of some most common gas sensors types.

Amperometric sensors due to high sensitivity and good dynamic properties are frequently used in toxic gas concentration monitoring [7]. Sulphur dioxide amperometric sensor with solid polymer electrolyte of our own design was investigated in this paper. Details of the experiment and sensor construction can be found elsewhere [8, 9]. The response (value of current) of this sensor at various gas flow-rates in two mixtures of high purity gases, namely synthetic air and 100 ppm SO₂, is presented in Figure 1. The gas flow was controlled with Brooks mass flow controllers and changed in steps from 10 mL per minute (mLPM) to 90 mLPM. In both gas compositions, the increase of gas flow resulted in the increase of current response. In synthetic air the instability effect is visible, but relatively small. In 100 ppm of SO₂, however, this effect is more significant. In case of the amperometric sensor it is a diffusion of gas through the porous electrode membrane that limits the measured current. Therefore, increasing flow of the gaseous analyte over the sensor electrode surface results in the current increase.

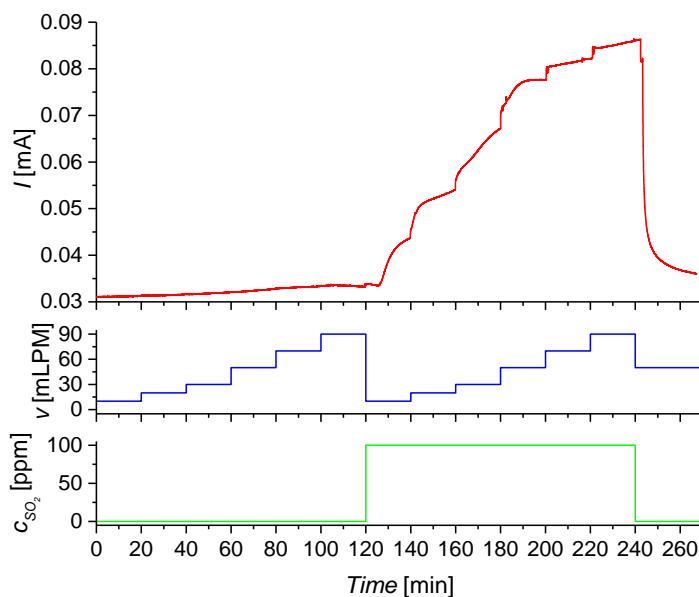

Figure 1. The response of the amperometric sensor at various gas flow-rates.

Similar experiment have been performed with semiconductor gas sensor. This time commercially available sensors GGS1331, GGS2331, GGS3331 (all from Umweltsensortechnik GmbH), TGS2600 and TGS880 (both from Figaro Engineering Inc.) have been used. Each sensor work at the operation temperature suggested by manufacturer in the application note. Such sensors, also referred as metal oxide sensors, in the presence of reducing or oxidizing gases change their resistance. The sensors response to the step change of gas flow from 0 mLPM to 80 mLPM is presented in Figure 2. It can be seen that the gas flow rate influence all sensors response. For each sensor, an introduction of gas flow causes increase of sensors resistance. It can be explained by the lowering of the sensor operating

temperature by gas flowing over sensor surface. The resistance change is different for each sensor, in case of the GGS 2331, the resistance for 100 mLPM is almost 5 times higher than for gas not flowing.

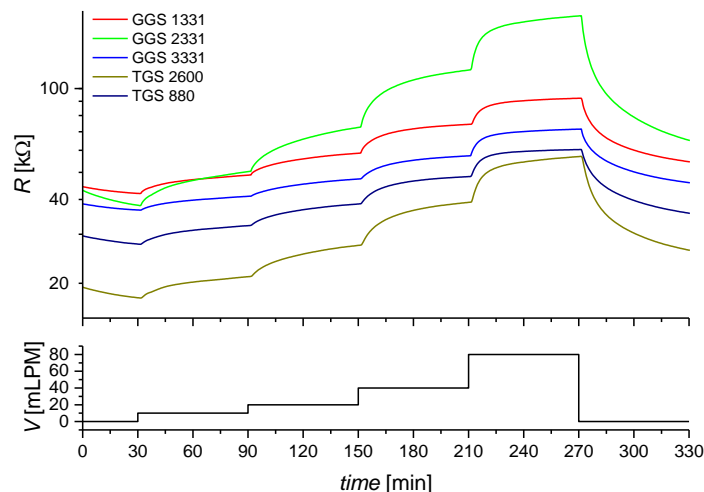

Figure 2. The response of the commercially available common semiconductor gas sensor at various gas flow-rates.

Based on above results, it can be concluded, that the gas flow rate influence different gas sensor response and it should be taken into consideration during measurements. Maintaining known and constant gas flow rate seems to be a good strategy. Alternatively, more complex procedure can be introduced, e.g. stop-flow mode of operation [10]. This mode can be accomplished by the alteration of gas flow in measuring chambers in controlled way.

3. Experimental set up

Preliminary studies have shown that a system for controlling gas flow rate requires feedback in the form of gas flow measuring circuit. Honeywell's Zephyr™ Digital Airflow Sensors seems to be good candidates for this purpose. HAF Series of such sensors are designed to measure mass flow of air and other non-corrosive gases. The Microelectronic and Microelectro-Mechanical System (MEMS) sense die is located in a precise and calculated airflow channel to provide repeatable flow response. These sensors provide a digital interface for reading airflow. With thermally isolated heater and temperature sensing elements, they provide a fast response to the air or gas flow.

They are available in standard flow ranges, from ± 50 standard cubic centimeter per minute (scm) to ± 750 scm, and are fully calibrated and temperature compensated with an on-board Application Specific Integrated Circuit (ASIC). All presented result are for two HAF sensors, namely HAFBLF0750CAAX5 and HAFBLF0100CAAX5, having the ranges of ± 750 scm and ± 100 scm, respectively. The main advantages of HAF sensors are their low price, high accuracy and easy integration with electronics using digital interface.

First, we checked HAF sensors accuracy and usefulness in developed system. As a reference source of gas flow a cylinder of compressed synthetic air and Tylan mass flow controllers (MFC) were used. Desired gas flux was set with MFC, and the readings from both HAF sensors were measured. Each measurement was repeated 20 times. Statistical analysis have been done. Measurements are gathered in Table 1. The obtained result prove that both sensor are very accurate and stable. In all cases, error during measurements with HAF sensor is smaller than 1%.

Table 1. HAF sensor calibration with Tylan MFC.

Flow set with MFC [sccm]	HAF sensor with 100 sccm range [sccm]	Standard deviation [sccm]	HAF sensor with 750 sccm range [sccm]	Standard deviation [sccm]
100.0	99.7	0.02	99.9	0.09
90.0	90.0	0.04	88.9	0.26
80.0	79.2	0.11	79.1	0.15
70.0	69.2	0.05	68.9	0.06
60.0	59.7	0.10	58.8	0.00
50.0	49.4	0.06	49.0	0.25
40.0	39.1	0.08	39.3	0.00
30.0	29.5	0.06	29.5	0.06
20.0	19.5	0.06	19.5	0.14
10.0	9.5	0.06	9.3	0.06
0.0	0.1	0.04	0.2	0.00

Considering the above, an electronic module was proposed to control and stabilize the gas flow rate at a desired value based on AVR microcontroller. Microcontroller is responsible for communication with the rest of the electronic nose system (I2Cmain). Microcontroller build-in Two Wire Interface (TWI) bus, which is I²C compatible, is used. Microcontroller is acting on this bus as a SLAVE device with individually set slave address. For configuration of the HAF sensor a two unused pins of the microcontroller are controlled using software procedures. This way communication of ATmega8 and HAF sensor is manually realized in MASTER mode. As a result, it is possible to read digital value of gas flow.

Another task of the microcontroller is to control the air intake. Two solutions have been proposed, usage of pump from blood pressure meter, powered with nominal 3 V voltage, and DC fan (Comair Rotron Flight II FS12B3), powered with nominal 12 V. Both approaches have been investigated in more details. In each case, microcontroller PWM signal was used for obtaining different average voltages and a result a gas flow management. In case of the fan, a TACH signal was measured as a feedback of rotation speed. Designed module block structure is shown in Figure 3.

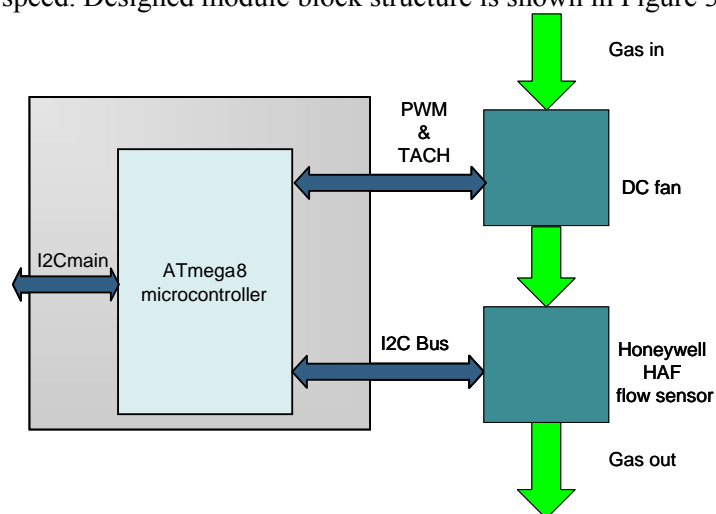
**Figure 3.** Block diagram of the proposed module

4. Results of the tests

Obtained result for the blood pressure meter pump are collected in Table 2. All measurements were repeated 20 times, averaged and standard deviation was calculated. Measurements have been made using two lengths of the silicone tube with an inner diameter 3 mm, which connects the pump to the measuring cell. Relatively high maximum flow rates have been obtained. Unfortunately, the pump is very unstable source of air flow, and as a result, the gas flow is highly irregular. Value of standard deviation is very high in relation to obtained gas flow. Large fluctuations in flow make the pump useless as part of the proposed system.

Table 2. Pump calibration with HAF sensor for different tube length.

Pump supply voltage [V]	140 cm tube length		490 cm tube length	
	Flow [sccm]	Standard deviation [sccm]	Flow [sccm]	Standard deviation [sccm]
1.0	171.7	70.73	148.4	95.60
1.5	280.7	113.01	297.9	91.74
2.0	347.7	107.98	366.0	106.77
2.5	429.9	93.90	443.5	121.72
3.0	276.5	119.88	440.4	115.69
3.5	627.6	91.26	399.8	103.89

Table 3. DC fan calibration with HAF sensor for different tube length.

Fan supply voltage [V]	140 cm tube length		490 cm tube length	
	Flow [sccm]	Standard deviation [sccm]	Flow [sccm]	Standard deviation [sccm]
3	10.7	0.24	5.2	0.27
6	44.1	0.29	18.5	0.23
9	100.5	1.21	39.1	0.96
12	169.8	2.26	67.7	1.11
15	250.5	3.10	101.1	1.82
18	308.2	3.93	126.7	2.28

Obtained result for the DC fan are collected in Table 3. The data are presented in a similar manner to the one described earlier in case of the pump. Flow fluctuation measured in case of the fan are in acceptable level. The obtained data show that there is no basic relation between supply voltage and gas flow rate. Additionally, values of air flow depend on the length of the tubes. It is showing the need to use of the flow sensor in the proposed system.

Finally, DC fan was chosen as a most suitable solution. Proposed module is controlled with simple dedicated software. Microcontroller repeatedly polls the HAF sensor and correct PWM factors according to error value of feedback loop (difference between value of desired flow set by supervising module and current flow reading).

5. Conclusions

The paper presents inexpensive module for measuring and controlling gas flow rate. It is used as a component of electronic nose system employed for classifying and distinguishing different levels of contamination in air. The hardware part of the system consists of a number of independent, single-board modules working in parallel. They are connected each other using I²C bus, which can be controlled by software of supervising module [11].

6. References

- [1] Nenov T G and Yordanov S P 1996. *Ceramic sensors: technology and applications* (Lancaster, Technomic Pub)
- [2] Kalinowski P and Jasinski G 2013 *PhD Interdisciplinary Journal* **1** 99
- [3] Smulko J M, Trawka M, Granqvist C G, Ionescu R, Annanouch F, Llobet E and Kish L B, 2015 *Sensor Review* **35** 340
- [4] Strike D J, Meijerink M G H and Koudelka-Hep M 1999 *Fresenius J. Anal. Chem.* **364** 499
- [5] Sberveglieri, G 1992 *Gas Sensors: Principles, Operation and Developments* (Springer)
- [6] Liu S-J, Shen H-X and Feng J-X 1995 *Anal. Chim. Acta* **313** 89
- [7] Jasinski P 2006 *Mater. Sci. Poland* **24** 269
- [8] Chachulski B and Gebicki J 2006 *Sens. Actuator B-Chem.* **119** 435
- [9] Strzelczyk A, Jasinski G and Chachulski B 2013 *PhD Interdisciplinary Journal* **3** 21
- [10] Szczurek A, Maciejewska M, Flisowska-Wiercik B and Bodzój L 2010 *Sens. Actuator B-Chem.* **148** 522
- [11] Jasinski G, Kosciński P, Strzelczyk A, Wozniak L and Lentka G 2015 Low cost measurement module for matrix of amperometric gas sensor *Proc. of XXI IMEKO World Congress: Measurement in Research and Industry* (Prague, Czech Republic, 30 August-4 September)

Acknowledgments

This work was partially supported by the National Centre for Research and Development, project LIDER No. 22/103/L-2/10/NCBiR/2011, and State Budget Funds assigned for statutory activity.