

INTEGRATED PRODUCTION TECHNOLOGY OF CYLINDRICAL SURFACES BY TURNING AND BURNISHING

Włodzimierz Przybylski

Summary

The method is based on a combination of previously used two separate operations namely machining and burnishing in a one complex operation implemented on a lathe. The application of such a complex machining operation on a single work station is a technological innovation with high economic efficiency. In one pass of special cutting-burnishing heads three processes: semi-finishing, finishing and strengthening by cold work are realized. In this way, the costly operations like, shafts grinding or holes honing can be eliminated. In the case of the proposed technology, e.g. in the production of hydraulic cylinders, machining time for piston rods and cylinders can be about 6 times shorter in relation to the conventional technology (with grinding or honing). Integrated machining with turning and burnishing is particularly effective and recommended for use on dedicated CNC machines with numerical control. Discs or rollers for generation of plastic deformation in the surface layer are placed in the back of the head. In the case of machining shafts and hydraulic cylinders of steel C45 is possible to obtain a surface roughness $R_a = 0,16 - 0,32$ micrometers, dimensional accuracy class 7-8 according to ISO standards, and increase in the hardness of the surface up to 40%.

Keywords: surface plastic deformation, burnishing process, turning, burnishing tools and equipment

Zintegrowana technologia cylindrycznych powierzchni z zastosowaniem toczenia i jednoczesnego nagniatania

Streszczenie

W pracy przedstawiono zintegrowaną metodę – jednoczesne toczenie (lub roztaczanie) i nagniatanie powierzchni cylindrycznych w jednej operacji na specjalizowanych tokarkach. Metodę cechuje duża efektywność – obróbka odbywa się w jednym przejściu roboczym specjalnych głowic skrawająco-nagniatających. Głowice wykonują jednocześnie obróbkę kształtującą i wykończeniową z jednoczesnym umocnieniem warstwy wierzchniej w wyniku plastycznego odkształcania. Obróbka może zastąpić szlifowanie długich wałów lub gładzenie (honowanie) głębokich otworów. Zalecana jest szczególnie w technologii tłoczków i cylindrów hydraulicznych siłowników – czas obróbki ok. 6 razy krótszy w porównaniu do technologii tradycyjnej (ze szlifowaniem lub honowaniem). Opisane konstrukcje głowic skrawająco-nagniatających zostały sprawdzone w badaniach laboratoryjnych i przemysłowych na tłoczkach i cylindrach hydraulicznych siłowników wykonanych ze stali C45. Uzyskano chropowość powierzchni – R_a w zakresie $0,16-0,32 \mu\text{m}$ i dokładność wykonania średnic w zakresie 7-8 klasy wg ISO. Twardość warstwy wierzchniej zwiększyła się po nagniataniu o ok. 40%.

Słowa kluczowe: odkształcanie powierzchniowe, nagniatanie, narzędzia do nagniatania

Address: Prof. Włodzimierz PRZYBYLSKI, Gdansk University of Technology, Faculty of Mechanical Engineering, Narutowicza st.11/12, 80-233 Gdansk, Poland, e-mail: wprzybyl@pg.gda.pl

1. Introduction

In the contemporary technology of machines and devices different sorts of machining are applied as well as more often plastic processing. Among varieties of plastic processing, burnishing (Fig. 1) is applied, mainly as finishing processing for shafts, holes or tracks, etc. [1-4].

Burnishing is surface plastic processing [5] that can be carried out on turning machines as finishing processing. In the process of burnishing chip, sparks or dust are not being produced. Liquids which are necessary in case of applying abrasive processing are unnecessary in burnishing [6-8].

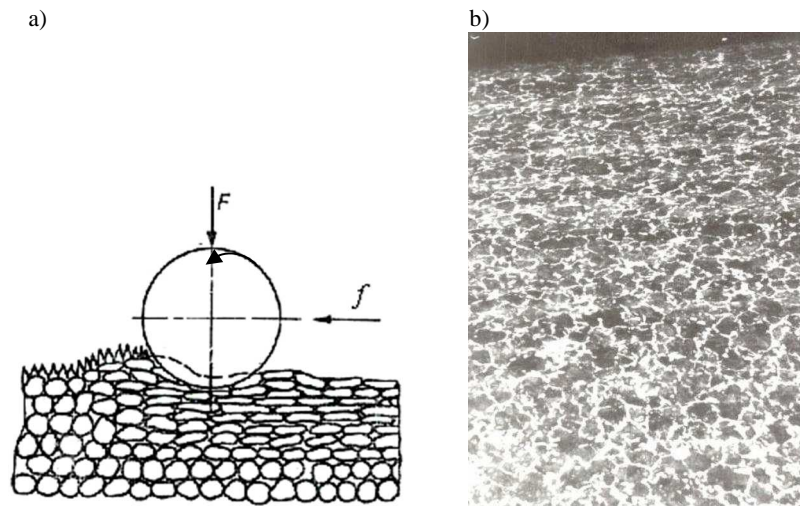

Fig. 1. Plastic deformation in the surface layer of the workpiece during burnishing process, where: F – force, f – feed (a) and structure of surface layer after burnishing by rolls of steel 0.45% C (magn. $\times 250$) (b)

Processing can be applied by burnishing in the technology of the machinery part to the purpose [9-13]:

- of reducing the roughness of the area,
- of increasing the resistance to the fatigue (surface and volume),
- of increasing the hardness of outer layer,
- increasing the resistance to the abrasive wear and tear and erasing,
- of removal expenses of producing machines.

Applying tools for burnishing on precision NC machines and machining centres enables the concentration of treatments of processing shaping and finishing on one workstation. In many cases grinding performed on other workstation is unnecessary what is reducing production costs [7, 8]. In certain

cases also replacing thermal improving by electromechanical burnishing of the surface of machines' part is possible [6].

Most common way of burnishing cylindrical surfaces on CNC lathes was presented on Fig. 2 [4]. As part of one operation and in one fastening one by one a concurrence of turning and burnishing. The toolmaker's machine tool with tools fastened in the head is being carried out. Such means of implementation of the treatment of finishing processing by burnishing [14] are favourable on account of the accuracy of processing.

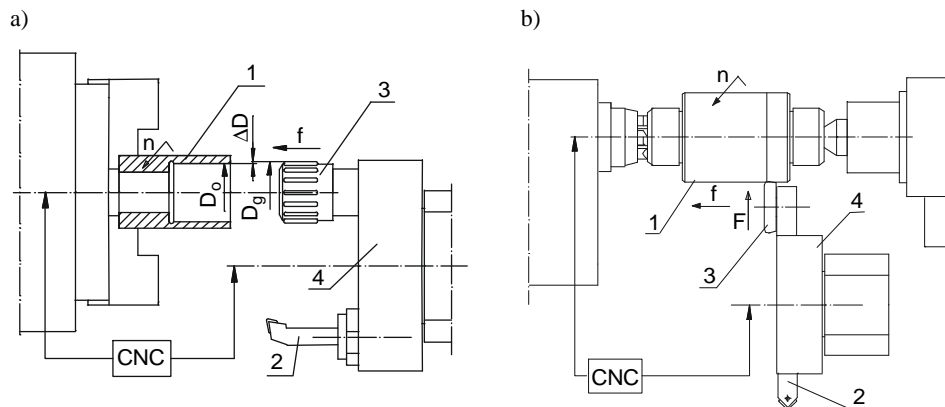

Fig. 2. Basic methods of burnishing cylindrical inside surfaces (a) and outside surfaces (b) on CNC lathes: 1 – machined part, 2 – cutting tool, 3 – burnishing tool, 4 – tool head

2. Integration of turning and burnishing

For time reduction of processing it is possible to perform treatments of turning and burnishing in the same time, applying the same longitudinal feed. For processing integrated in this way one should use the special instrumentation [15, 16] or special machine tools, called turning-burnishing machine.

In figure 3 essential cinematic outlines of processing were presented. Processing with one burnishing element (Fig. 3 a) can be applied for processing of shafts with the small slenderness, however treatments from Fig. 3 b and Fig. 3c can be applied for processing of shafts with the great slenderness (even when $l/d = 20$), because burnishing part, containing a lot of burnishing elements coating oneself along accurate running tracks, is fulfilling simultaneously the function of steady.

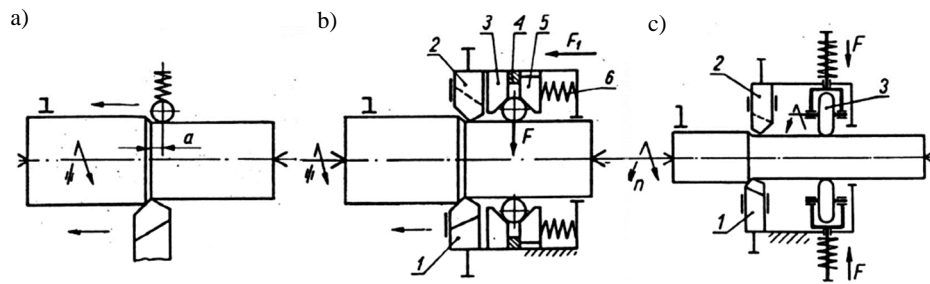

Fig. 3. Machining methods by simultaneous turning and burnishing of shaft parts (a) single-ball burnisher, (b) multiroller turning and burnishing head, (c) two-roller head: 1 – roughing tool, 2 – finishing tool, 3 – burnishing unit, 4 – distance ring, 5 – ball track, 6 – spring

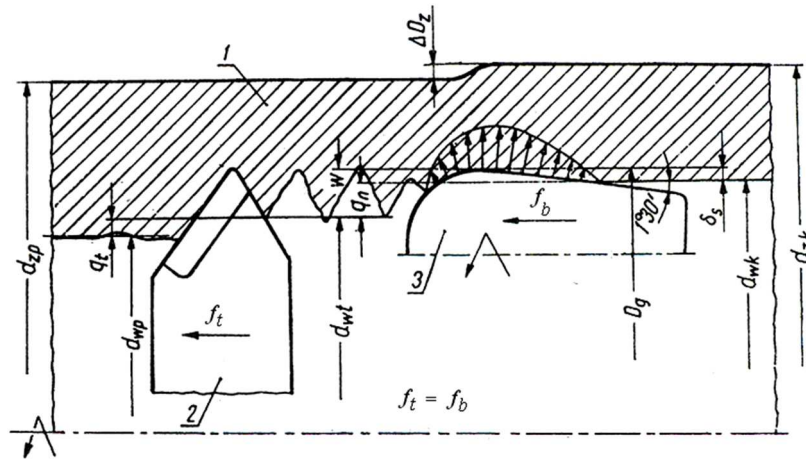

Fig. 4. Plastic deformation in the workpiece as a result of cutting and burnishing process, where: 1 – machined cylinder, 2 – cutting tool, 3 – burnishing rolls

3. Turning and burnishing of hydraulic cylinders

In case of integrated processing (Fig. 4) of cylinders through chambering with simultaneous burnishing using the special chambering-burnishing head. The example of the construction of such a head for processing of cylinders about the diameter of 180 H8 was placed on Fig. 5 (patent no. PL 90483). In part machining three knives were put, from which one is finishing tool with the thorough tuning radial line feed. The burnishing part consists of two rows of burnishing elements which are balls (8) and barrel rolls (6), having the possibility of the independent change of the dimension tool setter. Inside the head channels and holes being placed, in which machining liquid is running across and simultaneously is rinsing out chips toward the spindle of the machine tool. Shavings cannot get up to burnishing elements, therefore the machine tool must have the system of the filtration of liquid and the extorted circulation.

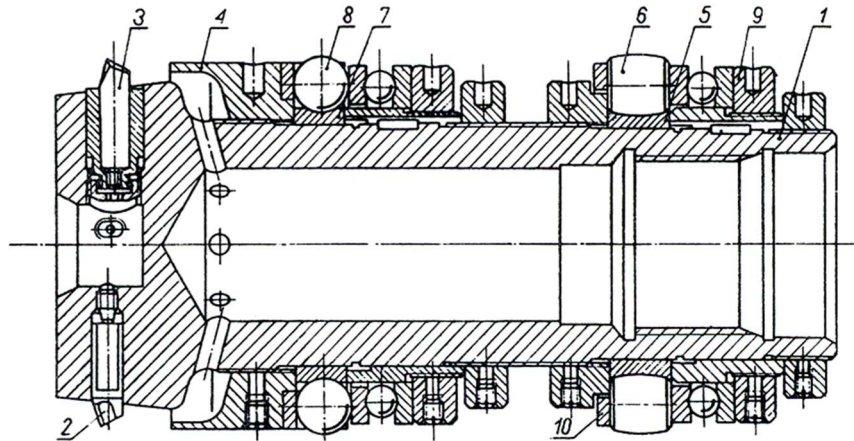

Fig. 5. Head design, where: 1 – body, 2 – boring rough tool, 3 – turning finishing tool, 4 – adjusting nut, 5 – rolls' raceway, 6 – barrel rolls (for fine surface finishing), 7 – distance sleeve, 8 – burnishing balls (for hardness increase), 9 – blocking nut, 10 – rolls' basket

Applying boring-burnishing heads requires the adaptation of the universal lathe (Fig. 6) [6] or of special machine tool – similar to the horizontal drill for deep holes. The machining head is being fixed on the special hollowed rod and during processing it does not turn (Fig. 6). This method can be applied for processing of holes about the demanded roughness $R_a = 0.16 - 0.32 \mu\text{m}$ in the IT 8 class of proper dimensions with the following parameters of processing (for cylinders of steel C45): $v_c = 100 - 120 \text{ m/min}$; $f = 0.2 - 0.3 \text{ mm/rev}$, allowance for burnishing $w = 0.05 - 0.08 \text{ mm}$ at the expense of cooling liquid about 5 l/sec.

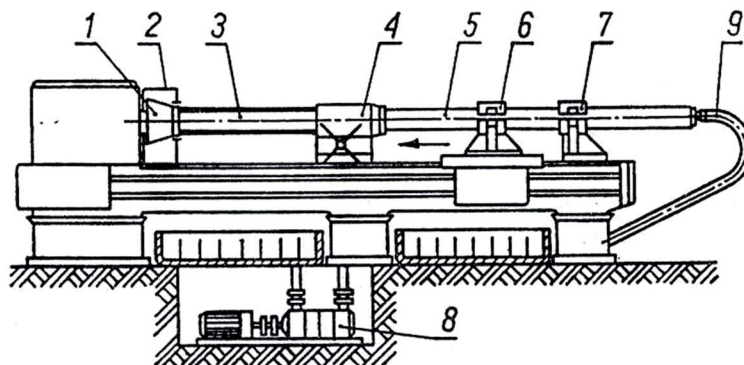

Fig. 6. Working station for simultaneous cutting and burnishing of hydraulic cylinders, where: 1 – chuck, 2 – guard, 3 – cylinder workpiece, 4 – guideclamping unit, 5 – hollow rod, 6 – carriage and rod chuck, 7 – reat, 8 – cooling pump, 9 – cooling supply conduit

Figure 7 presents the boring-burnishing head located inside of the hydraulic cylinder and a segment with surfaces before and after burnishing. On Figure 8 roughness of surface of the hydraulic cylinder of sleeve is shown. The sleeves were made of steel C45 and processed with boring-burnishing head (Fig. 7).



Fig. 7. A view of the boring-burnishing head in the hydraulic cylinder and a cylinder segment before and after machining

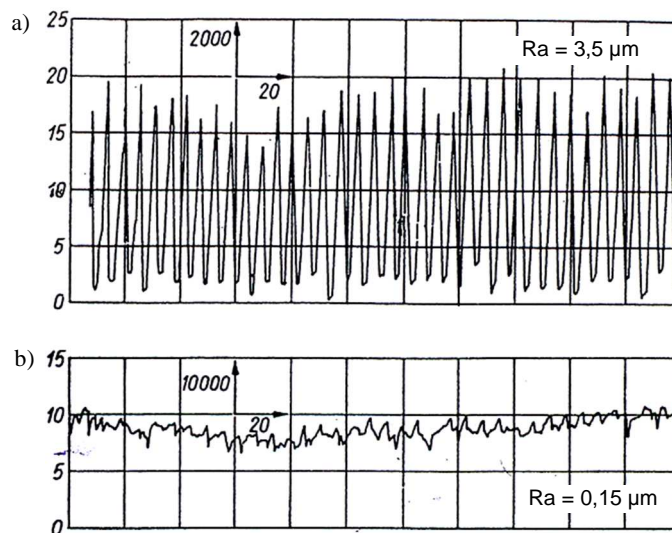

Fig. 8. Profilograms of surface's roughness of the hydraulic cylinder of sleeve made of 45 steel processed with boring-burnishing tool: (a) – surface roughness after turning, (b) – surface roughness after burnishing; processing parameters: processing speed $v_c = 2$ m/s, feed $f = 0,2$ m/rev, burnishing interference $w = 0,08$ mm

4. Turning and burnishing machine Tur 50 CNC-N for long shafts

As the result of research works conducted at the Gdansk University of Technology, in cooperation with FAT PONAR Wroclaw, machine was built TUR 50 CNC-N for the processing accomplishment integrated (Fig. 9) for shafts through turning and burnishing [16]. The machine (Fig. 10) is equipped into the CNC driver of the Sinumerik type 810 T and two measuring probes LP2H – Renishaw (Fig. 11) for measurements of the workpiece and putting position of the lathe tool.

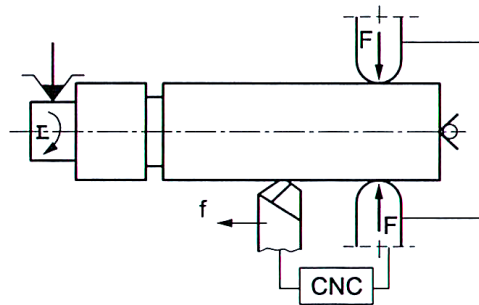

Fig. 9. Scheme of simultaneous turning and burnishing process of long shafts on CNC lathe: F – press forces of three rolls, f – feed of cutting tool and burnishing rolls

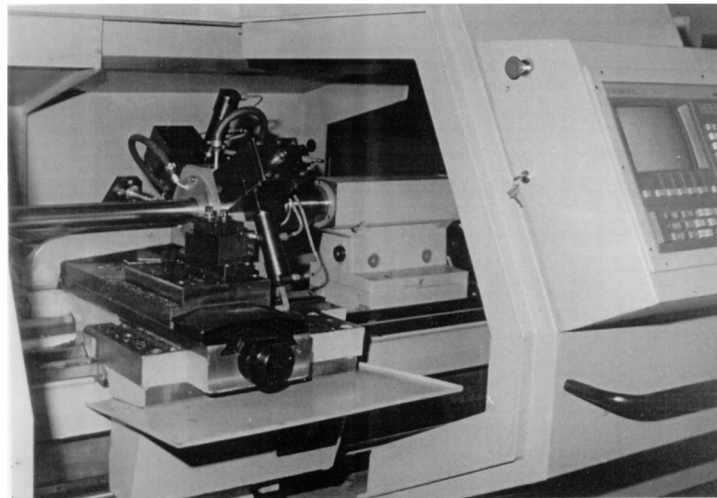

Fig. 10. Special machine type TUR 50 CNC-N for long shafts manufacturing in one pass by simultaneous turning and burnishing process, equipped with the control system SINUMERIC 810T

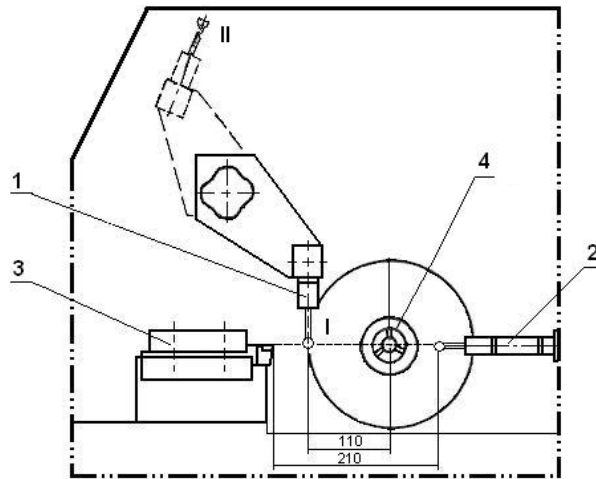

Fig. 11. Placement of measurements probes in working space of TUR 50 CNC-N: 1 – measuring probe LP2H Renishaw, 2 – part's probe, 3 – cutter gripper, 4 – spindle with holder

Basic specifications of turning and burnishing machine TUR 50 CNC-N were placed in table 1.

Table 1. Technical data of the turning and burnishing lathe TUR 50 CNC-N

Lp.	Specification	Type or volume	Dimensions
1	Scope of worked diameters of shafts	20–100	mm
2	Maximum length of worked objects	1750	mm
3	Length of bed	2000	mm
4	Scope of the rotation speeds of the spindle (in 3. scopes)	27–2240	mm
5	Processing feed	5–3200	mm/min
6	Speeded feed	5000	mm/min
7	Power of main engine	10	kW
8	Scope of burnishing force	1,2–10,5	kN
9	Number of burnishing rolls	3	
10	Diameter of burnishing rolls	60	mm
11	Numeric CNC driver type with masuring option	Sinumerik 810T	
12	Number of programmable axis	2	
13	Precision of axis	0,0005	mm
14	Weight	3600	kg

After starting of turning process of shaft three burnishing rolls are automatically pushed near to shaft's surface (fig. 12). Next two of them are staying jammed by devices (5), and one stays under the influence of the plumbing pressure. In this way an arrangement is being created steady movable for the

worked roller which is simultaneously turned and burnished. It enables processing of every diameter of slender shafts in scope 20 – 100 mm and lengths up to 1750 mm without resetting the machine tool.

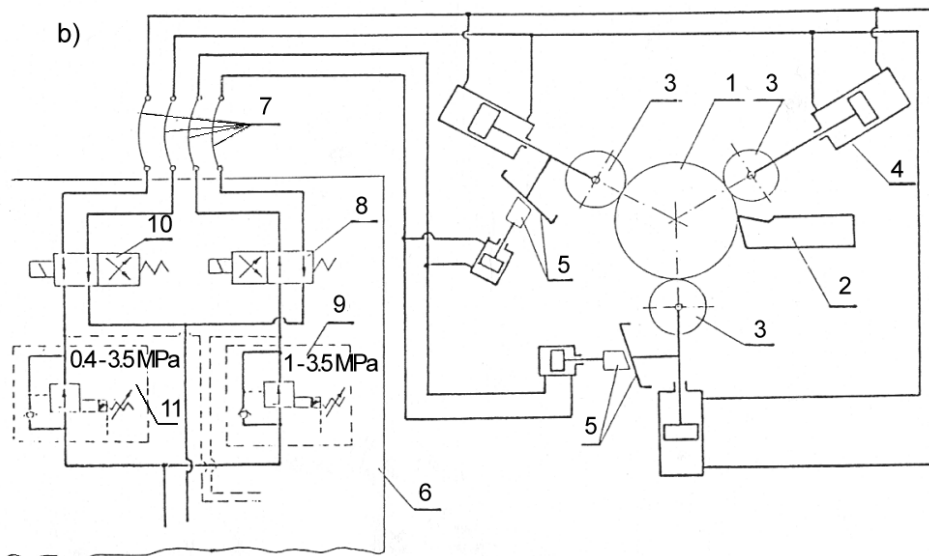

Fig. 12. Schematic arrangement of turning and burnishing machine TUR 50 CNC-N: 1 – processed element (shaft), 2 – cutter, 3 – burnishing rollers, 4 – working hydraulic cylinder, 5 – blocking wedge, 6 – oil supply unit, 8,10 – control valves, 9, 11 – reducing valves

Processing of shafts on turning and burnishing machine is running according to the following automatic cycles (Fig. 13):

- I. Turning the phase and the segment of the shaft from the side of tailstock to the length of 120 mm.
- II. Moving away the knife from the object and withdrawing the saddle.
- III. Inserting rolls (at the reduced number of turnovers) to the turned surface throughout the phase on the object and beginning the process of burnishing.
- IV. Automatic blocking two sliders with burnishing rollers, return of the knife of the previous place on the object and beginning simultaneous processing with carrying on with burnishing.
- V. Moving away the knife from the object, will draw aside rolls finishing off the process of burnishing and turning the inflow of cooling liquid off.
- VI. Fast return movement of the saddle to the initial location (by the tailstock), including the inflow of the airflow draining the worked area.
- VII. Measurement of the diameter of the object with the help of the measuring probe and next automatic unfixing the worked object.

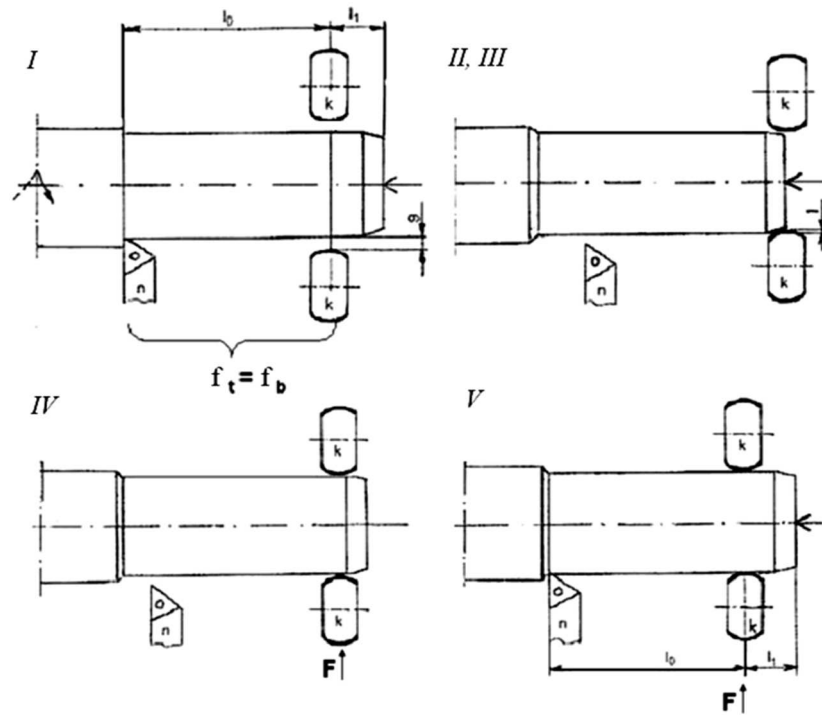

Fig. 13. Working cycles of manufacturing the shaft on TUR 50 CNC-N by turning with burnishing process, F – force of burnishing, f_i – feed for turning, f_b – feed for burnishing

To the purpose of the non-admission of chips coming into existence in the zone of burnishing to the zone airflow springing toward the spindle between the round aperture and the object was applied. The stream of this air is also sucking cooling liquid and this causes that the object during processing is being very well cooled.

5. Researches for piston rod processed on turning-burnishing machine TUR 50 CNC-N

Confirming the usefulness of integrated processing by carrying on was an aim of conducted technological examinations of burnishing shafts and slender piston rods when $l/d \leq 20$. The research were conducted on samples (piston rods) of steel C45 about the diameter 56 mm and lengths 700-1000 mm. These samples were being worked on turning-burnishing machine Aurochs 50 CNC – N in the following technological conditions (established in preliminary examinations): $n = 560$ rev/min, $f = 0.22$ mm/rev, $g = 0.35$ mm, $F = 2.1$ kN, diameter of discs $D = 60$ mm, radius of circles $R = 30$ mm, TNMG 160404 TC 35 lathe tool, at

one working passing the head with abundant cooling with liquid and air. The roughness of the area after turning was $R_{at} = 5\text{--}10\ \mu\text{m}$, and after burnishing should take the value of $R_{ab} \leq 0.32\ \mu\text{m}$. Attempts were being repeated three times for every associating parameters. Findings were announced in Table 2.

In picture 14 is placed profilogram of surface of the piston rod about the diameter of 56 mm of steel C45 after processing with turning and after burnishing. Roughness of the area in given conditions of processing ($F = 4\ \text{kN}$, $f = 0.2\ \text{mm/rev}$, $R = 30\ \text{mm}$) reduced from $R_a = 8.1\ \mu\text{m}$ after turning up to $R_a = 0.28\ \mu\text{m}$ after burnishing.

Table 2. Experimental results of turning and burnishing of hydraulic piston rods on the turning–burnishing lathe TUR 50 CNC–N

Length of piston rods l	Roughness R_a	Diameter range d	Radial whipping		Surface hardness increase HB
			medium value	maximum value	
mm	μm	μm	μm	μm	%
700	0,27	20	13	20	33,0
	0,29	5	23	40	39,5
	0,30	10	19	28	35,7
	0,28	10	8	10	36,0
1000	0,28	5	50	70	36,8
	0,36*	5	40	60	38,6
	0,30	5	10	15	38,0
	0,27**	30	126	60	46,0

* – feed $f = 0,42\ \text{mm/rev}$,

** – two burnishing cycles

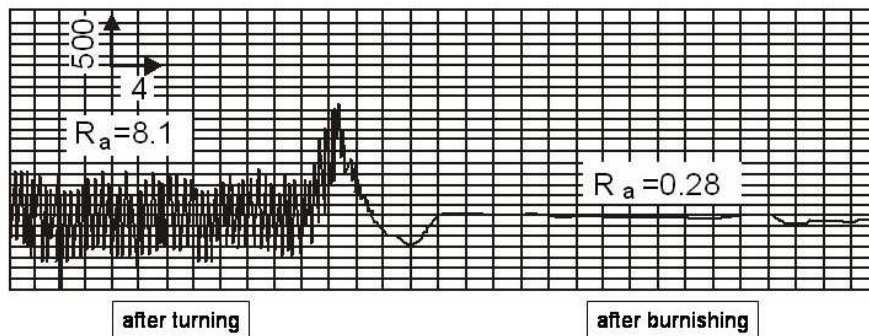

Fig. 14. Profilogram of the piston rod surface $\varnothing 56\ \text{mm}$ and $l = 1000\ \text{mm}$ after turning combined with burnishing operation rollers $D = 60\ \text{mm}$, $R = 30\ \text{mm}$; machining conditions: roller pressure $F = 4\ \text{kN}$, feed $f = 0.18\ \text{mm/rev}$

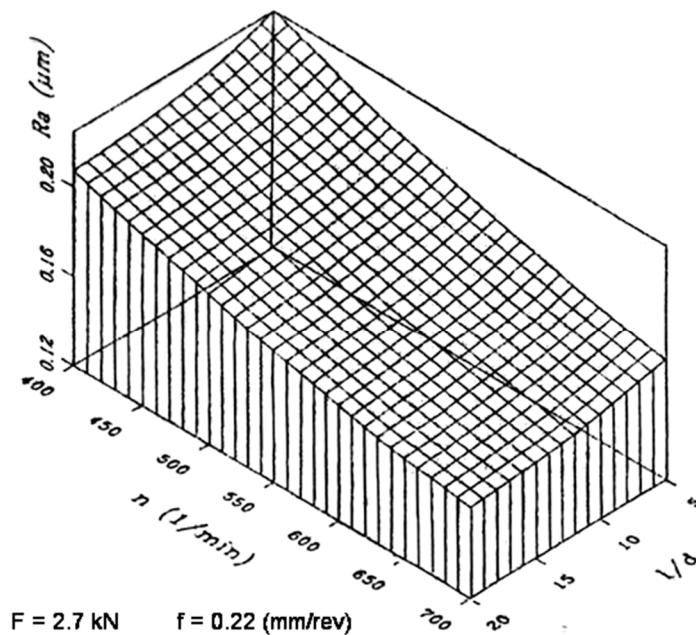

Fig. 15. Surface roughness after burnishing (Ra) by three-roller head as dependence of slenderness ratio (l/d) and rotational speed of a shaft (n) with diameter $\phi 56$ mm and length 1000 mm (n)

Average surface roughness Ra in a function of the spindle rotational speed (n) and a slenderness ratio (l/d) of the shafts (rods) processed during integrated turning-burnishing process on the lathe (type TUR 50 CNC-N) is presented in Fig. 15.

6. Conclusions

By building turning-burnishing machine it was showed above all that integrated processing was possible with turning and burnishing shafts about the great slenderness ($l/d \leq 20$) in one working passing of the plumbing head with three rolls. This method peculiarly is recommended for group processing of shafts and piston rods of plumbing servomotors. This is a method reducing the time of processing of such parts much in relation to traditional processing by separate turning and grinding with the use steady.

It is possible however to take the following conclusions out of technological examinations carried out:

1. Using surface plastic processing with burnishing is very favourable for the technology of hydraulic and pneumatic cylinders. The outer layer's hardness increase at about 40% and the roughness of the surface reaches value of $Ra = 0,16$

to 0,32 μm . It also get lower friction factor then surfaces machined with honing technology.

2. Applying turning-burnishing machine TUR 50 CNC–N it is possible to achieve the following results: reducing the surface roughness after turning about 25 times, value of roughness $Ra = 0.27 \mu\text{m}$ in one working passing the burnishing head is possible. Tolerance of the dimension of the diameter of worked piston rods $\varnothing 56 \times 1000 \text{ mm}$ was in scope $5 \div 30 \mu\text{m}$ and the deviation of the roundness about 5 μm .

3. As a result of burnishing shafts of steel C45 it is possible to reach the height of the hardness of the surface about 40 % what is creating possibilities of resigning in certain cases from the expensive operation of surface hardening long shafts and piston rods.

4. Integrated processing with turning and burnishing on the machine tool of TUR 50 CNC-N can be applied for making shafts and piston rods about $l/d \leq 20$, accuracies of turning the diameter out in IT 7 – IT 8 about the roughness of the area $Ra = 0.32 \mu\text{m}$. Long shafts should however be before processing anneal with a view to removing technological internal stresses.

References

- [1] K. CZECHOWSKI, W. POŁOWSKI, Ł. JANCZEWSKI, J. KALISZ: Wydajne nagniatanie gładkościowe wałów o dużej smukłości. *Mechanik*, **86**(2013).
- [2] K. KALINSKI, W. PRZYBYLSKI: Modelling and analysis of the dynamics of the shafts burnishing process. *Machines Vibration*, **2**(1993).
- [3] W. PRZYBYLSKI, M. SIEMIĄTKOWSKI: Determining manufacturing conditions in integrated CNC turning-burnishing process planning. W: Proceedings of the 9th International DAAAM Symposium, Cluj-Napoca 1998.
- [4] W. PRZYBYLSKI, M. SIEMIĄTKOWSKI: Selecting manufacturing variants of shafts using integrated CNC turning-burnishing technologies. Annals of DAAAM Symposium, Vienna 1999.
- [5] K. SKALSKI, A. MORAWSKI, W. PRZYBYLSKI: Analysis of contact elastic-plastic strains during the process of burnishing. *International Journal of Mechanical Sciences*, **5**(1995).
- [6] W. PSZIBYLSKI: Technologia powierzchniowej plastycznej obróbki. Metallurgija, Moskwa 1991.
- [7] W. PRZYBYLSKI: Development and importance of burnishing technology in computer integrated manufacturing. Developments in Mechanical Engineering, Gdansk University of Technology, Gdansk 2005.
- [8] W. PRZYBYLSKI, J. WOJCIECHOWSKI, M. KLEINER, A. KLAUS: Badania wpływu obróbki nagniataniem na wytrzymałość złączy rurowych. *Archiwum Technologii Budowy Maszyn i Automatykacji*, **26**(2006)2.
- [9] S. DZIONK, W. PRZYBYLSKI: Surface Waviness of Components Machined by Burnishing Method. *Archives of Mechanical Technology and Automation*, **32**(2012)2.



- [10] W. GRZESIK: Polepszenie jakości technologicznej i użytkowej części z materiałów utwardzonych. Część III. *Mechanik*, **85**(2012)12.
- [11] W. GRZESIK, K. ZAK, M. PRAZMOWSKI: Surface integrity of hard turned parts modified by ball burnishing. *Journal of Machine Engineering*, **12**(2012)1.
- [12] J. KACZMAREK, W. PRZYBYLSKI: The surface contact characteristics after sliding and rolling burnishing. *Advances in Manufacturing Science and Technology*. Quarterly of PAN, **26**(20020)1.
- [13] A. RODRIGUES: Surface improvement of shafts by the deep ball-burnishing technique. *Surface and Coatings Technology*, **206**(2012).
- [14] Z. MACHYNIA, J. KALISZ, K. CZCHOWSKI: Some aspects of modeling of roller burnishing. *Mechanik*, **86**(2013)12.
- [15] W. PRZYBYLSKI, M. SIEMIĄTKOWSKI, B. SCIBIORSKI: Computer aided synthesis and evaluation of cellular machining system solutions incorporating burnishing technologies. *Conferences on Computer Integrated Manufacturing (CIM'99)*. Warsaw 1999.
- [16] W. PRZYBYLSKI, J. SCISŁOWSKI, J. ZIELINSKI: Device for simultaneous turning and burnishing of shafts. Patent PL nr 161449, Warszawa 1993.

Received in May 2016

