

## JOINTS OF STEEL SANDWICH STRUCTURES

**Janusz Kozak**

Gdańsk University of Technology, Poland

\* Corresponding author: [kozak@pg.edu.pl](mailto:kozak@pg.edu.pl) (J. Kozak)

### ABSTRACT

*Steel sandwich structures are perceived as alternatives to single-skin welded structures in the shipbuilding industry due its advantages like significant reduction of mass in relation to typical single skin structure. However, beside problems with their strength properties itself, applications in real structures requires of solving the problem of joining, both for connection sandwich to sandwich as well as sandwiches to single-shell structures. Proper design of joints is connected with some factors like lack of attempt to interior of panel, introduction of additional parts and welds with completely different stiffness. In the paper the results of laboratory fatigue tests of selected joints as well as numerical calculation of stressed for different kind of joints of sandwich structures are presented. As result of calculations optimisation of geometry for selected joints is performed.*

**Keywords:** steel sandwich; joints; strength; laboratory test

### INTRODUCTION

Modern ship represents complex engineering object consists of wide spectrum of materials and requires often sophisticated manufacturing technologies. Among modern materials can be mentioned: composites [1], [2] or with elastic memory [3]. Such materials are often used in yacht [4] or floating objects like ramps [5]. In the same time new joining techniques like underwater welding [6], [7] has been introduced and these have also had an impact on the shipbuilding industry.

One example is laser welding techniques, which have slowly started to prove their potential as alternative methods of joining. Such capabilities give the chance of changing the configuration of a typical ship skin structure into a “steel sandwich” representing two shells connected by an internal system of thin stiffeners (webs). A typical representative of such a structural part is a steel or aluminium panel manufactured from two shell plates of 3–4 mm in thickness, internally supported by a one directional system of stiffeners of ~40 mm in depth, with all components connected by laser welding, as shown in Fig. 1a.

The introduction of internal stiffeners makes possible to create required strength characteristics of panel. Examples of the possible forms for stiffeners are shown in Fig. 1b.

One of the barriers for overcoming the application of such panels in ship structures is joining, for both one panel to another and a panel to a classical single-skin structure. The joining problem arises from both the closing of internal space of the panel and from the disproportion of thicknesses of shell plating. Such a problem generates the necessity for new designs of such joints [8, 9].

### METHODS FOR JOINING OF PANEL STRUCTURES

Among the methods for the joining of panel structures, one can distinguish mechanical (bolts, riveting and kneading), thermal (welding) or chemical (bonding) methods. Bonded joints have significant advantages, such as a lack of stresses and deformation due to cold junctions in comparison to welding

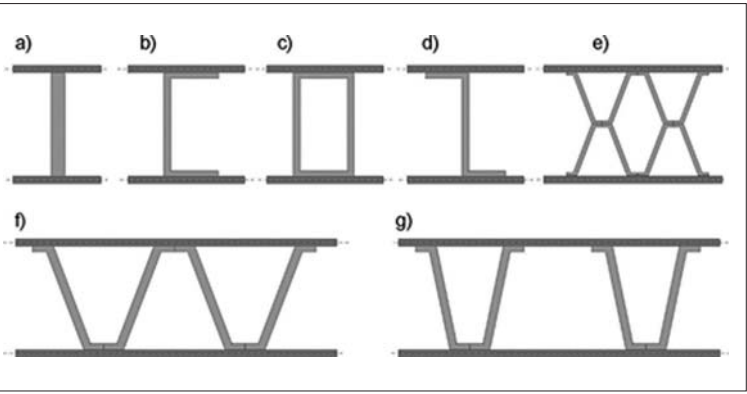

Fig. 1. a) Panel type I-core and b) potential configuration of stiffeners

processes. A significant disadvantage of these joints is their low resistance at higher temperature. Impact and vibration load resistance are also subjects of study [10].

Problems regarding the joining of metals by bonding have been the subject of several research projects. One of the proposed solutions is using intermediate elements fixed by bonding by: epoxy resin, polyurethane or cellular concrete. Examples of such proposals are presented in Fig. 2 [11].

For the above-mentioned reasons, welding remains a fundamental method for joining. The geometry of joints can be done by some approaches; for instance, by dedicated

prefabricated joining elements like square tubes, angle bars or directly by tabled joints [12]. One can find some other solutions, as presented in Fig. 3. Most simply direct butt joint of faces of skin is not applicable due to technological reasons – butt weld of shell plating thickness of 2.5 mm not guarantee proper quality of weld as well as stiffness and strength parameters.

An angular connection can be done using a similar method, as illustrated in Fig. 4.

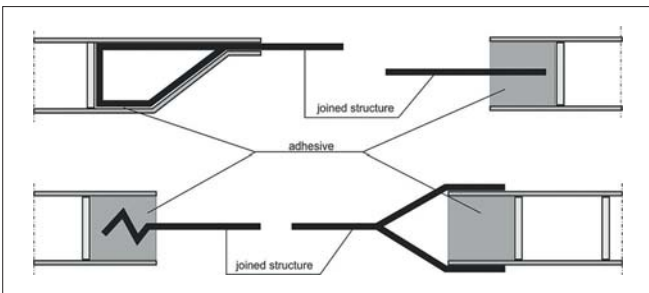

Fig. 2. Selected proposals for bonded joints [11]

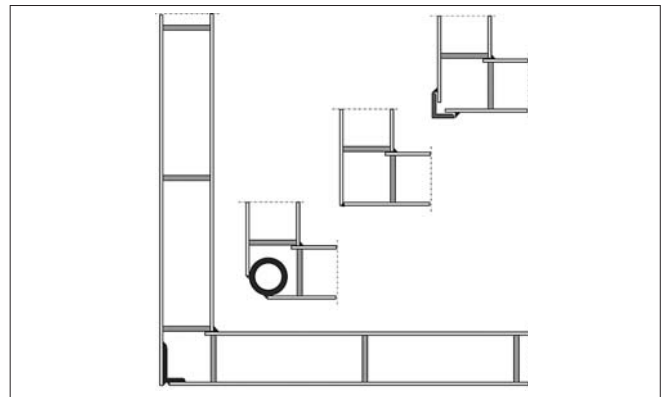

Fig. 4. Examples for panel-panel angular connection

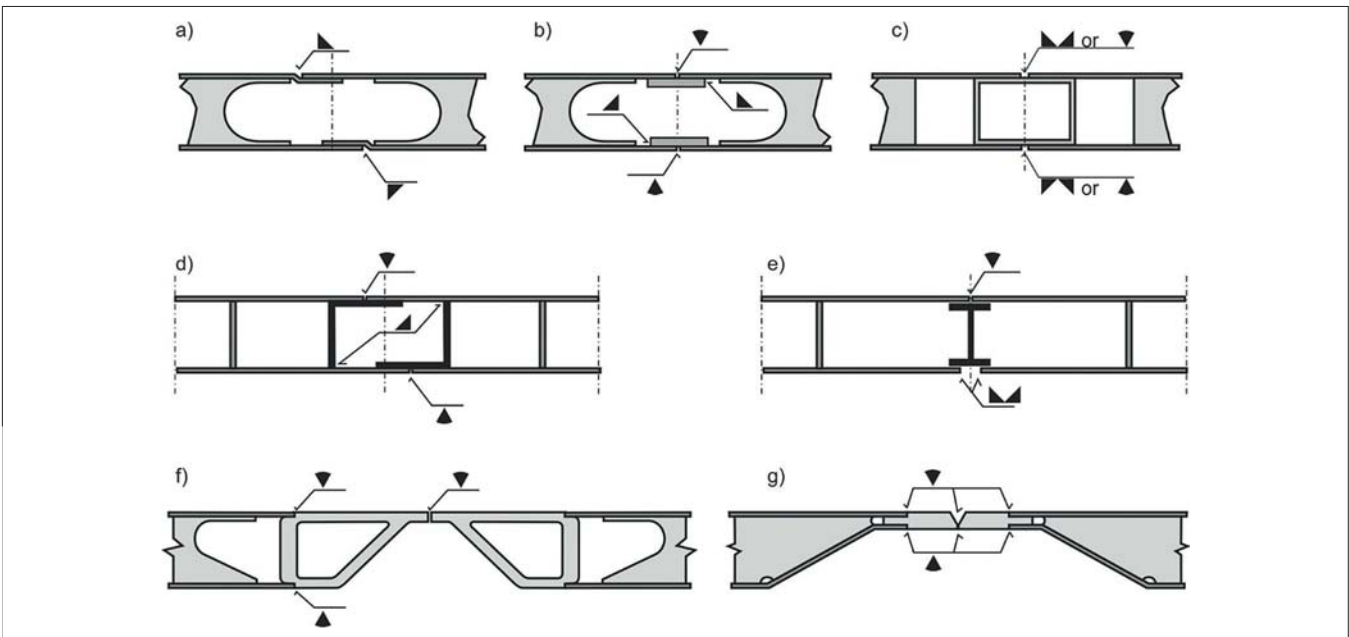

Fig. 3. Examples of butt welded panel-panel joints: a) without additional parts; b) by flat bar; c) by square tube; d), e) by rolled profile; f), g) with reduction of thickness

## LABORATORY TEST OF NATURAL SCALE SANDWICH-SANDWICH JOINTS

Due to problems with the theoretical modelling of strength properties of sandwich panels, especially regarding their fatigue [13], [14], laboratory tests of natural scale structures are still the most credible source of information [15].

Two variants of joints were subjected to testing: by flat bar with a thickness of 2.5 mm (Fig. 3b) and by square tube with dimensions of 40×40×3 mm (Fig. 3c). For comparison, the same geometry of panel without joint was tested on a specimen width of 200 mm. All specimen were made form panels of plates thickness 2.5 mm, stiffened by flat bars 40×4 mm 120 mm spanned. Figure 5 shows the specimen ready for testing and model on the test stand is shown in Fig. 6. Application of load via actuator 250 kN was controlled by Instron Labtronic 8800 system.



Fig. 5. Model of joint during preparation

All models were tested under sinusoidal load with a stress ratio  $R = 0$ .



Fig. 6. Model during test

An example of destruction is presented in Fig. 7. Analysis of the process of failure shows that both types of joint fatigue crack initiates in the middle part of joint, in fusion line of one of joining weld and propagates in the joining element to the edge of specimen, towards the weld.

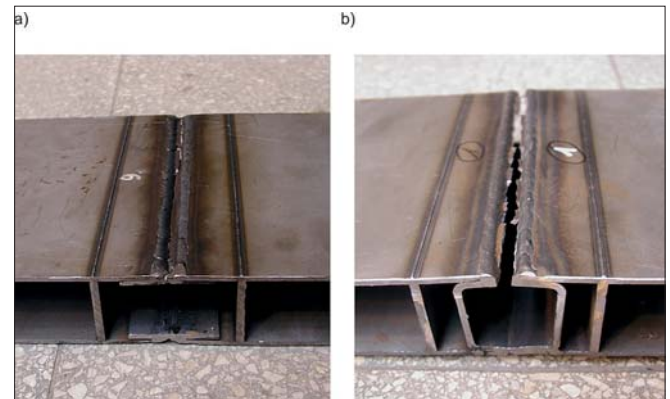

Fig. 7. Example of destruction: a) joint by flat bar; b) joint by square tube

A summary of the test results is presented in Fig. 8.

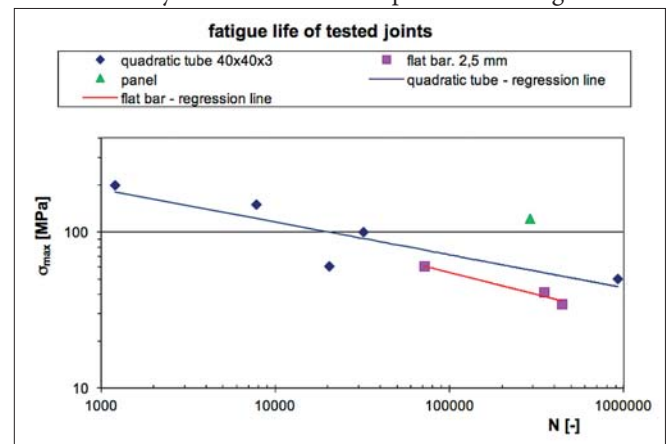

Fig. 8. Fatigue test results for selected joints

The analysis of the presented results shows that the fatigue life of the joint by flat bar is lower than for the square tube; however, the results for both joints present lower durability than the pure panel itself. The qualitative results are presented in Fig. 9.

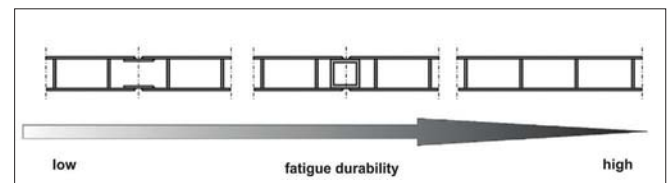

Fig. 9. Quantitative presentation of fatigue life of tested joints

## PARAMETRIC STUDY OF GEOMETRY FOR SELECTED JOINTS

As discussed, there are some problems with the theoretical modelling of the strength properties of sandwich panels. The specific geometry and material structure of the laser-welded joints require very careful modelling of the geometry of the laser weld, material zones around it, as well as some phenomena occurring under load. The laser weld while loading passes

three operation stages [15, 16]: rotation of the joined elements; contact of the plating with the stiffener; common displacement of the plating and the stiffener in the same direction. In order to reflect the nature of rotation, relevantly defined “contact regions” must be introduced at selected stiffener edges.

As presented above, the fatigue life of the tested joints presents significant diversification. Such a wide spectrum of results suggests the need for an individual approach to a given configuration, load-boundary condition and due to the complex geometry, this optimisation must be multi-parametric. One possibility for such an optimisation is acquisition of knowledge on properties of particular solution of joint like stress to weight ratio in the form of a catalogue based upon parametrised numerical solutions. Part of such an approach is presented below for selected geometries of butt panel-panel joints. Calculations are carried out for the geometries presented in Fig. 10.

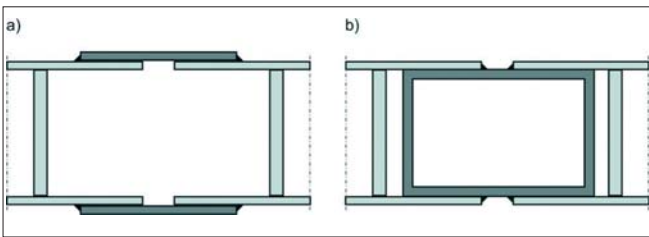

Fig. 10. Variants of geometry of analysed joints: a) cover plate; b) quadratic tube [17]

The model was made using ~15000 elements with applied double symmetry (minimum length element side of 0.1 mm) with both tension and compression loads. For modelling PLANE 183 element form ANSYS library have been used. The numerical model with its boundary and load conditions is presented in Fig. 11a [17].

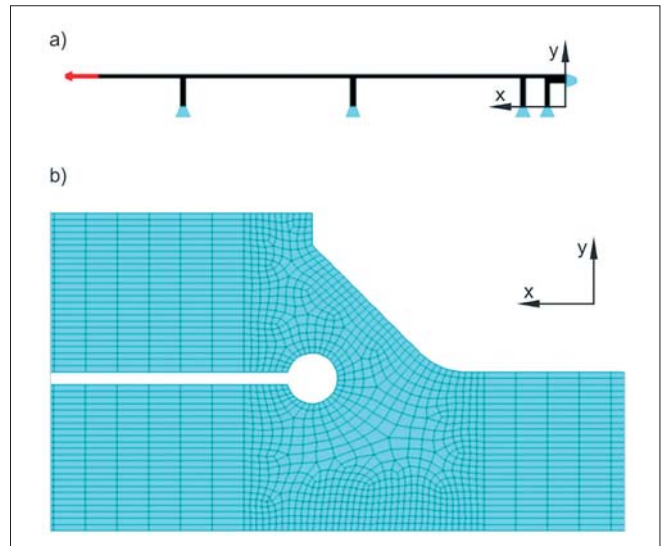

Fig. 11. Model of joint by square tube: a) boundary and load conditions; b) mesh [17]

To model the real behaviour of a laser welded joint, a circular concentrator was introduced to avoid singularity in some region of the joint [14]. The details of the model with the concentrator are presented in Fig. 11b.

The shell plating thickness, the height of the stiffeners and the density of the core material are treated as independent variables, while the geometry of the joint was linked to one, characteristic size and this parameter was treated also as a dependent variable.

The applied parametric variables are presented for both cases in Fig. 12. The height of the stiffener was constant at  $h_w = 40$  mm, the stiffener distance was 120 mm and the shell plate thickness was also constant at  $t_f = 2.5$  mm.

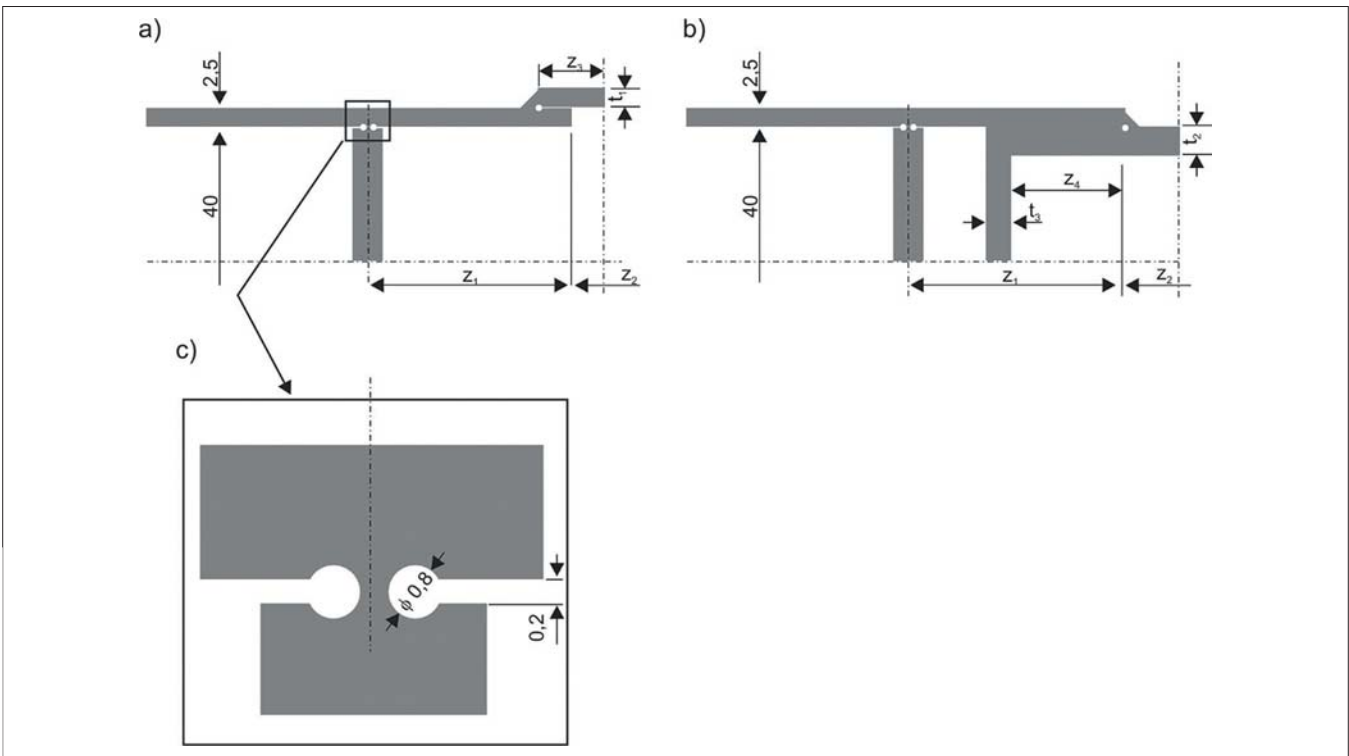

Fig. 12. Geometry and variables assumed for calculation of joints: a) by cover plate; b) by quadratic tube; c) model of connection between shell and stiffener



## MODEL OF JOINT BY COVER PLATE

The applied variation range of parameters describing the geometry during the parametrisation process of the model is presented in Fig. 13.

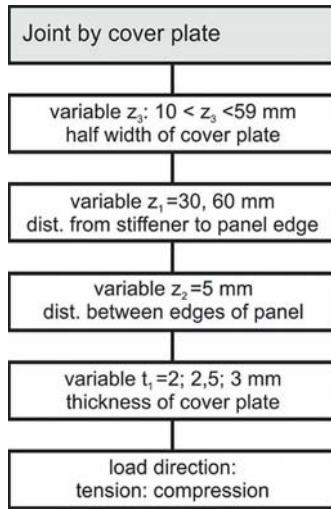

Fig. 13. Range of variation of parameters describing geometry

For the sake of comparison, calculations for different geometries and uniformisation of stresses were made by introducing of a geometric concentration factor  $k_g$ , defined as:

$$k_g = \frac{\sigma_{\max, \text{red.}}}{\sigma_{\text{nom}}},$$

where:

$\sigma_{\max, \text{red.}}$  – maximal reduced stresses of Huber-Mises;

$\sigma_{\text{nom}}$  – nominal stresses,  $\sigma_{\text{nom}} = \frac{P}{A}$ ;

$P$  – load;

$A$  – cross section of model area.

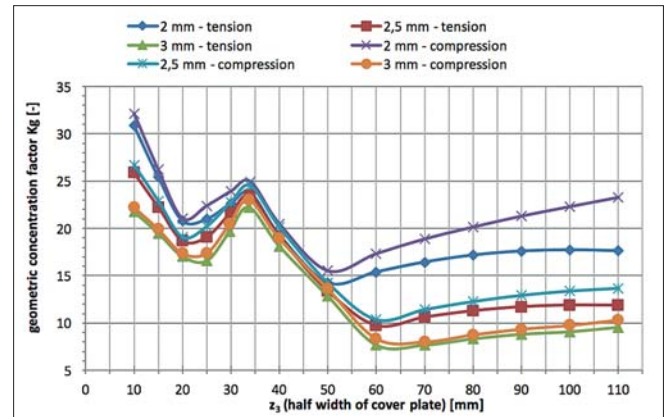

Fig. 13 Geometric concentration factor  $k_g$  for joint of panels by cover plate for  $z_1 = 30$  mm

Figure 13 shows the geometric concentration factor  $k_g$  for joint of panels by cover plate for  $z_1 = 30$  mm.

Due to the wide range of parameters applied for clarity of presentations, three-dimensional diagrams are presented below, where the vertical axis represents the geometric concentration factor  $k_g$  and each configuration of parameters is represented by one point in the diagram. For better visualisation of the results, smoothed surfaces using the distance-weighted smallest square method with Statistica were made.

Figure 14 shows the variation of geometric concentration factor  $k_g$  for the cover plate joint for two distances of panel edge from the first stiffener axis (see variable  $z_1$  in Fig. 12) for  $z_1 = 30$  mm in Fig. 14a and for  $z_1 = 60$  mm in Fig. 14b.

Analysis of Fig. 14 shows that it is possible to find local minimum of  $k_g$  both for thickness and for the width of the cover plate.

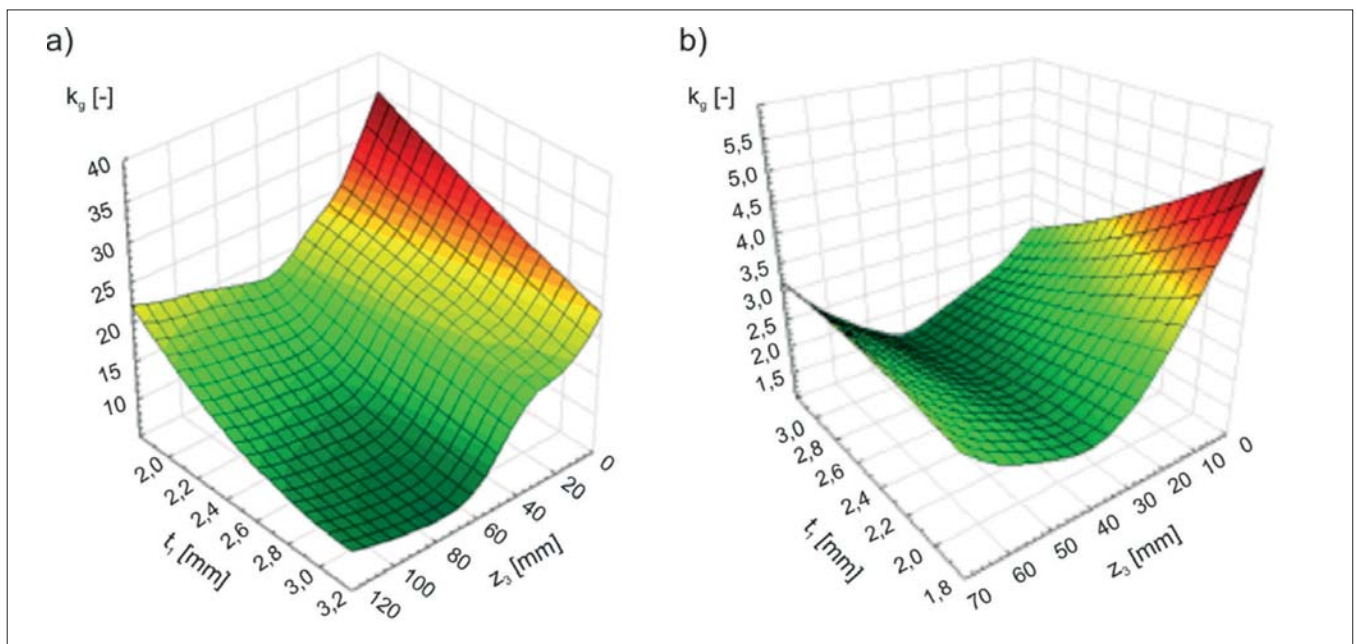

Fig. 14. Variation of geometric concentration factor  $k_g$  for cover plate joint for two values of distance of panel edge from first stiffener axis (see variable  $z_1$  in Fig. 12): a)  $z_1 = 30$  mm; b)  $z_1 = 60$  mm

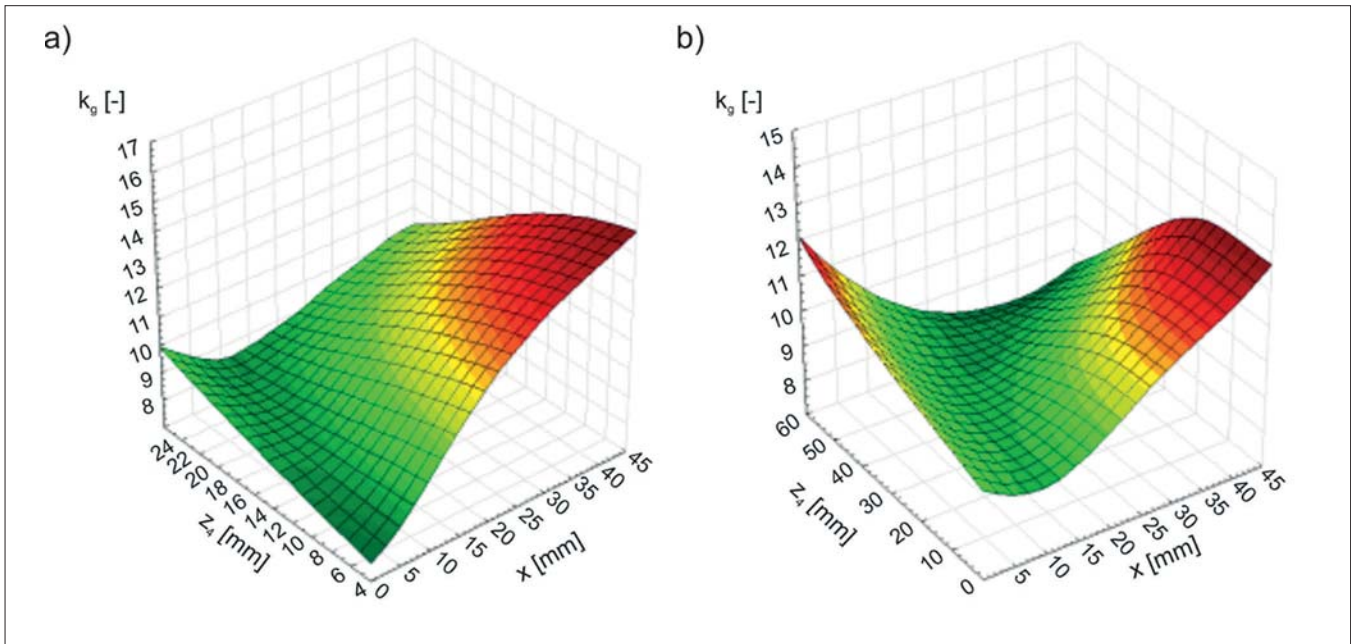

Fig. 15. Variation of geometric concentration factor  $k_g$  for quadratic tube joint for two values of distance of panel edge from first stiffener axis (see variable  $z_1$  in Fig. 12b): a)  $z_1 = 30$  mm; b)  $z_1 = 60$  mm, where:  $z_1$  – distance of panel edge from first stiffener axis (mm) (Fig. 12b);  $z_4$  – insertion of tube into panel (mm) (Fig. 12b);  $x$  – coordinate of location of point of stress concentration (mm)

## MODEL OF JOINT BY QUADRATIC TUBE

Following the approach presented for the cover plate joint, the same calculations were made for the joint by quadratic tube. Figure 15 shows the variation of geometric concentration factor  $k_g$  for the quadratic tube joint as a function of insertion of tube into the panel (see variable  $z_4$  in Fig. 12b), as well as the distance from the centre line of joint  $x$  for two values of distance of panel edge from the first stiffener axis (see variable  $z_1$  in Fig. 12b): for  $z_1 = 30$  mm in Fig. 15a and for  $z_1 = 60$  mm in Fig. 15b.

Similarly to the cover plate joint, one can distinguish a clear minimum of  $k_g$ , suggesting the existence of the optimal geometry of such a joint. By comparing the minimum of  $k_g$  for both presented geometries, one can find that the concentration coefficient  $k_g$  for the joint with the quadratic tube is significantly lower towards to the joint by cover plate.

Figure 16 shows a comparison of the geometric concentration factor  $k_g$  for both joints with different characteristics as a function of relative mass of the joint.

Beside of very low mass of joint to mass of panel ratio one is possible to observe some systematic relationship between geometric concentration factor and this very ratio for profile applied connection. For each type of geometry there is almost linear characteristic of such relation. But for cover plate connection there is region of geometrical parameters, where such relationship reverse its inclination and significant reduction of geometrical concentration factor is observed. It suggest to search optimal geometry on the left side of minimum of such distribution.

Such a parameter set is designed to give direct data to support the optimisation process of the joint geometry.

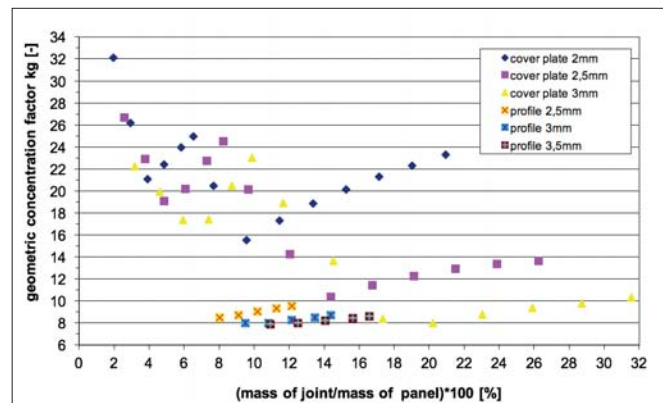

Fig. 16 Comparison of geometric concentration factor  $k_g$  for both joints with  $z_1 = 30$  mm  $z_2 = 10$  mm as a function of relative mass of joint, where: For joint by cover plate half width of cover plate (parameter  $z_3$  Fig. 12a) from left to right

– for cover plate thickness 2 and 2.5 mm: respectively 10, 15, 20, 25, 30, 34, 40, 50, 60, 70, 80, 90, 100 and 110 (mm);

– for cover plate thickness 3 mm: respectively 10, 15, 20, 25, 29, 33, 40, 50, 60, 70, 80, 90, 100 and 110 (mm).

For joint by quadratic tube insertion of profile into panel (parameter  $z_4$  Fig. 12b) from left to right:

– for thickness of profile 2.5 mm: respectively 5, 10, 15, 20 and 24 (mm);

– for thickness of profile 3 mm: respectively 5, 10, 15, 20 and 23.5 (mm);

– for thickness of profile 3.5 mm: respectively 5, 10, 15, 20 and 23 (mm).

## CONCLUSIONS

Steel sandwich structures are new promising structural materials. However, the problem of joining them with themselves and with neighbouring single-skin structures does limit their future possible applications. Such joints must present good strength properties together with relative low mass. Of course, the assembly of structures using such joints must be easy and possible to perform for typical manufacturing

conditions and equipment. Such needs require an optimisation process to be performed to reach a balance between the strength and weight.

- In the paper quantitative results from laboratory tests of sandwich-sandwich joints regarding fatigue properties are presented. The analysis of the results obtained shows that the fatigue life of the joint by flat bar is lower than for the square tube for given properties of geometry of joint.
- The parametrical process for numerical searching of influence of geometry on maximum stresses to mass ratio is presented. Methodology applied give supporting tool for searching of optimal geometry of joint. Obtained results shows possibility for performing optimisation process due to fact that there is possible to found parameters of geometry which presents minimum of stress concentration factor.

## REFERENCES

1. X. Li, Z. Zhu, Y. Li, and Z. Hu, 'Design and Mechanical Analysis of a Composite T-Type Connection Structure for Marine Structures', Polish Marit. Res., vol. 27, no. 2, 2020, doi: 10.2478/pomr-2020-0036.
2. N. N. Yang, T. Y. Zhao, J. G. Gu, and Z. P. Chen, 'Damage and Fracture Analysis of Bolted Joints of Composite Materials Based on Peridynamic Theory', Polish Marit. Res., vol. 26, no. 2, 2019, doi: 10.2478/pomr-2019-0022.
3. L. Matuszewski, 'Application of shape memory alloys in pipeline couplings for shipbuilding', Polish Marit. Res., vol. 27, no. 3, 2020, doi: 10.2478/pomr-2020-0049.
4. T. Niksa-Rynkiewicz, M. Landowski, and P. Szalewski, 'Application of apriori algorithm in the lamination process in yacht production', Polish Marit. Res., vol. 27, no. 3, 2020, doi: 10.2478/pomr-2020-0047.
5. T. Ferenc and T. Mikulski, 'Validation Process for Computational Model of Full-Scale Segment for Design of Composite Footbridge', Polish Marit. Res., vol. 27, no. 2, 2020, doi: 10.2478/pomr-2020-0037.
6. T. Urbański, A. Banaszek, and W. Jurczak, 'Prediction of Welding-Induced Distortion of Fixed Plate Edge Using Design of Experiment Approach', Polish Marit. Res., vol. 27, no. 1, 2020, doi: 10.2478/pomr-2020-0014.
7. K. Sun, Y. Hu, Y. Shi, and B. Liao, 'Microstructure Evolution and Mechanical Properties of Underwater Dry Welded Metal of High Strength Steel Q690E under Different Water Depths', Polish Marit. Res., vol. 27, no. 4, 2020, doi: 10.2478/pomr-2020-0071.
8. B. Metschkow and T. Graczyk, 'Laser welded joints in shipbuilding', Marine Technology II, WIT Press, 1999, p. 171-182.
9. F. Roland: Laser Welding in Shipbuilding – Chances and Obstacles. Kimm, Korea: Proceedings of the 8th Symposium on Laser Materials, 1997, p. 237-252.
10. BONDSHIP: Code part BONDSHIP guidelines\_tcm4-178376.pdf. <https://www.scribd.com/document/246094980/Code-Part-BONDSHIP-Guidelines> [attemp: 12nd February 2021].
11. M. Hentinen, M. Hildebrand, M. Visuri: Adhesively bonded joints between FRP sandwich and metal. VTT Tiedotteita – Meddelanden. Research Notes 1862. Technical Research Centre of Finland Espoo, 1979.
12. R. Pyszek: Strength assessment of a version of joint of sandwich panels. Polish Maritime Research, ISSN 1233-2585, Nr S1/2006.
13. P. Gallo, M. Guglielmo, J. Romanoff, and H. Remes, 'Influence of crack tip plasticity on fatigue behaviour of laser stake-welded T-joints made of thin plates', Int. J. Mech. Sci., vol. 136, 2018, doi: 10.1016/j.ijmecsci.2017.12.011.
14. K. Niklas and J. Kozak, 'Influence of the notch rounding radius on estimating the elastic notch stress concentration factor in a laser welded tee joint', in Materials Science Forum, 2012, vol. 726, doi: 10.4028/www.scientific.net/MSE.726.100.
15. J. Kozak, 'Selected problems on application of steel sandwich panels to marine structures', Polish Marit. Res., vol. 16, no. 4, 2009, doi: 10.2478/v10012-008-0050-4.
16. D. Boroński J. Kozak: Research on deformations of laser-welded joint of a steel sandwich structure model. Polish Marit. Res., vol. 2, no. 11, 2004.
17. K. Niklas, 'Search for optimum geometry of selected steel sandwich panel joints', Polish Marit. Res., vol. 15, no. 2, 2008, doi: 10.2478/v10012-007-0061-6.

## CONTACT WITH THE AUTHOR

**Janusz Kozak**  
*e-mail: kozak@pg.gda.pl*

Gdańsk University of Technology  
Narutowicza 11/12  
80-233 Gdańsk  
**POLAND**