

Load Testing of GFRP Composite U-Shape Footbridge

Łukasz Pyrzowski ¹, Mikołaj Miśkiewicz ¹, Jacek Chróścielewski ¹,
Krzysztof Wilde ¹

¹ Gdansk University of Technology, Narutowicza 11/12, 80-233 Gdansk, Poland

lukasz.pyrzowski@wilis.pg.gda.pl

Abstract. The paper presents the scope of load tests carried out on an innovative shell composite footbridge. The tested footbridge was manufactured in one production cycle and has no components made from materials other than GFRP laminates and PET foam. The load tests, performed on a 14-m long structure, were the final stage of a research program in the Fobridge project carried out in cooperation with: Gdańsk University of Technology (leader), Military University of Technology in Warsaw, and ROMA Co. Ltd.; and co-financed by NCBR. The aim of the tests was to confirm whether the complex U-shape sandwich structure behaves correctly. The design and technological processes involved in constructing this innovative footbridge required the solving of many problems: absence of standards for design of composite footbridges, lack of standardized material data, lack of guidelines for calculation and evaluation of material strength, and no guidelines for infusion of large, thick sandwich elements. Obtaining answers during the design process demanded extensive experimental tests, development of material models, validation of models, updating parameters and extensive numerical parametric studies. The technological aspects of infusion were tested in numerous trials involving the selection of material parameters and control of the infusion parameters. All scientific validation tests were successfully completed and market assessment showed that the proposed product has potential applications; it can be used for overcoming obstacles in rural areas and cities, as well as in regions affected by natural disasters. Load testing included static and dynamic tests. During the former, the span was examined at 117 independent measurement points. The footbridge was loaded with concrete slabs in different configurations. Their total weight ranged from 140 kN up to 202 kN. The applied load at the most heavily loaded structural points caused an effect from 89% to 120%, compared to the load specified by standards (5 kN/m²). Dynamic tests included standard actions (walking, running, synchronous jumps) as well as aggressive tests, all designed to confirm the usability of the footbridge. The performed trials allowed the identification of the modal and damping parameters of the structure. The designated first natural frequency with a value of 7.8 Hz confirmed the correctness of the U-shape cross-section design due to its significant structural rigidity.

1. Introduction

Composites made of fibre-reinforced polymers (FRP) are a modern material characterized by low volume weight, relatively high rigidity and strength, high resistance to atmospheric and chemical agents and a great range of geometrical shaping flexibility [1]. These advantages mean that use of polymer composites in various industries is increasing every year [2]. These advantages were also recognized by civil engineers, especially in design of bridges. The material is increasingly being used in selected structural elements, as well as whole objects. Some exemplary realizations can be found in [3-11].



The pedestrian and cycling footbridge in question, with a theoretical length of 14 m (figure 1) fits this trend. Its whole construction is made of composite materials. It is a compact, one-piece object produced using the technology of vacuum saturation with resin, arranged on a so-called dry structure (infusion), in a single production cycle. There are no joints or glued elements involved in the process. This solution provides long-time usability and significantly reduces the need for maintenance. The solution adopted in the version for mass production, can compete in terms of price in relation to relevant objects produced with traditional materials like steel, concrete or wood.



Figure 1. U-bridge located on the Gdańsk Technical University campus

The footbridge was constructed as a research object of the Fobridge grant, co-funded by the National Centre for Research and Development. Detailed information can be found in [12]. This project was carried out by a consortium consisting of Gdańsk University of Technology (leader), Military University of Technology and the Roma Sp. z o.o. company, located in Grabowiec near Toruń. The structure can be used to overcome the following obstacles: fast traffic roads, railways, canals and small rivers. The footbridge production process is very short; it takes only a few days. The small mass of the object - the object bridge weighs 3.2 tons – makes it easy to transport and install. These advantages can be used in case of necessity to quickly restore pedestrian passageways in natural disaster areas. The footbridge also facilitates emergency traffic of ambulances and service vehicles.

The research object - a full-sized bridge, after production at the Roma company plant, has been installed on the campus of the Technical University of Gdańsk. Due to the innovative design and technological solutions, a series of tests has been designed, beyond the scope of typical footbridges acceptance tests. The scope of research included: short-term static and dynamic tests and long-term rheology control static tests, including continuous monitoring. The period in which the bridge was subjected to a multi-faceted research amounted to more than a year. All tests have provided satisfactory results.

At the moment, the footbridge was transported back to the Roma company. It is prepared for installation at the Radunia river canal, where it will form a section of the pedestrian and cycling tract between Pruszcz Gdański and Gdańsk.

2. Footbridge description

The object is a composite, shell pedestrian footbridge with a cross-section resembling the letter U (figure 2). It is a structure with a freely supported static scheme, with a theoretical span of 14.0 m and a useful width of 2.6 m. The shell type girder is made of layered material (sandwich) in which the outer linings are made of glass fibre-reinforced polymer (GFRP) laminates, with a polyethylene terephthalate (PET)

foam core inside. The entire structure is made without joints, in a single production cycle, using infusion technology (figure 3). The object is characterized by a very low structural height, only 0.11 m.

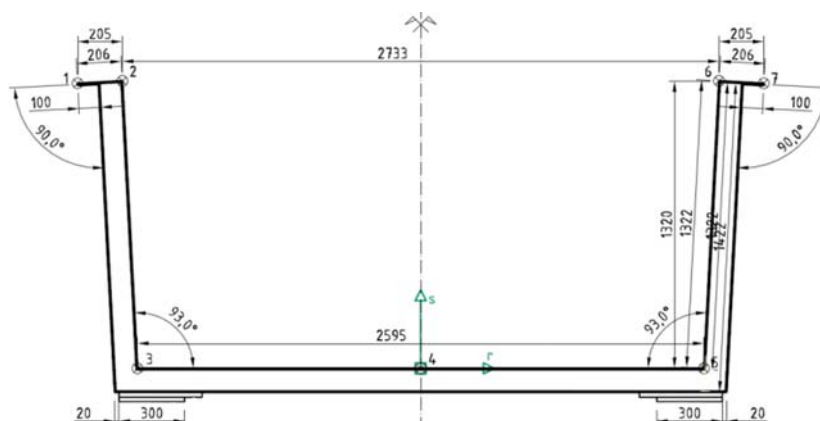

Figure 2. U-bridge footbridge cross-section



Figure 3. U-bridge footbridge production process

3. Footbridge numeric model

To create an acceptance research program, that is: choose a ballast, select locations for measurement points and choose adequate sensors, it was necessary to create a numerical model of the structure. This model was made using an finite element method (FEM), within the Abaqus 6.14 system. The construction of the main model was preceded by numerous validation tests, from small structures [13], to a full-size segment of the bridge with a length of 3 m [14].

The object was modelled using four-node shell elements for laminates and eight-node solid elements for a construction foam. A relatively fine division into finite elements was applied, with assumed size of approx. 0.04 m. The final calculations were preceded by a formal analysis of the mesh convergence. The model visualization including the finite elements mesh, is shown in figure 4. The static analysis included geometrically linear calculations in order to check the structure response to the ballast and non-linear computations to check a threat of global or local loss of stability. The performed dynamic analysis allowed to designate structure's basic characteristics, which are frequencies and mode shapes.



Figure 4. Visualization of the footbridge numerical model

4. Scope of research

The essential experimental research took place on 13 May 2015. The research program has been greatly expanded beyond the typical set of bridge acceptance tests. It was divided into two main parts: static - two ballast settings and dynamic – pedestrian forcing, modal hammer and an exciter. Due to its span, the theoretical object should be considered as small, but due to the cognitive aspects resulting from its unique character, a large number of monitored parameters has been adopted. During tests, a total of 216 various types of measurement points have been used to identify the behaviour of the structure and a laser scanning was performed on one side of the girder.

In addition, due to the need to assess the variability of the composite parameters in operating conditions with the passage of time, research was repeated twice more, in three-month intervals. Their scope again included static and dynamic tests. In addition, between the second and third batch of tests, a ballast equivalent to a human load resulting in $\sim 100\%$ designed effort was placed on the object for over three months. This type of full-size, long-term utility tests of objects under extreme load are performed very seldom. In the case of the composite Fobridge project research object, this is an extremely valuable verification experience. During all short and long-term bridge load tests, as well as during its everyday use, the structure response has been continuously monitored through a multi-threaded structural health monitoring (SHM) system. More details on this can be found in [15].

5. Static tests

The static behaviour of test object, in the form of a full span, was tested by laying concrete slabs on its deck, in various configurations. The total weight of the slabs, depending on the stage of the study, ranged from 140 kN to 202 kN. This load, in the most exacted points of the structure, caused effects ranging from 89% to 120% in relation to the 5 kN/m² load specified by standards. During all three independent test programs carried out on the footbridge, six static settings were realized. They were performed in two ways: divided into seven stages - each individual $\frac{1}{4}$ of the surface was loaded by turns; or divided into three stages - ballast was laid on consecutive halves of the deck. Example ballast configurations are shown in figure 5.

During static tests, the behaviour of the structure was monitored in 117 independent measurement points:

- 36 strain measurement points (21 strain gauges – SG, 12 vibrating wire strain gauges – VWSG, 3 fibre bragg grating strain sensors – FBG),
- 57 displacement measurement points (9 inductive, 48 geodesic),
- 4 elastomeric bearings deformation measurement points,
- 4 support settlement measurement points,
- 16 structure temperature measurement points.

Locations of strain gauge and optical fibre measurement points are shown in figure 6, and the points of measurement of displacements in figure 7.



Figure 5. Footbridge loaded with ballast during static tests

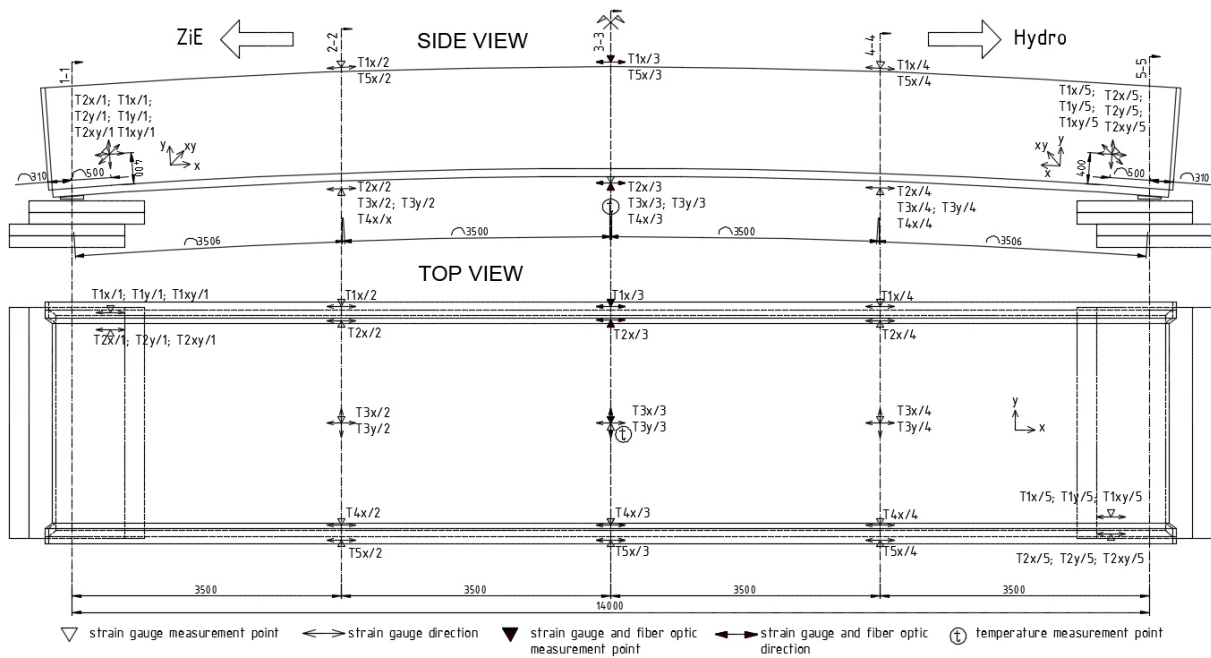

Figure 6. Locations of strain gauge and optical fibre strain measurement points

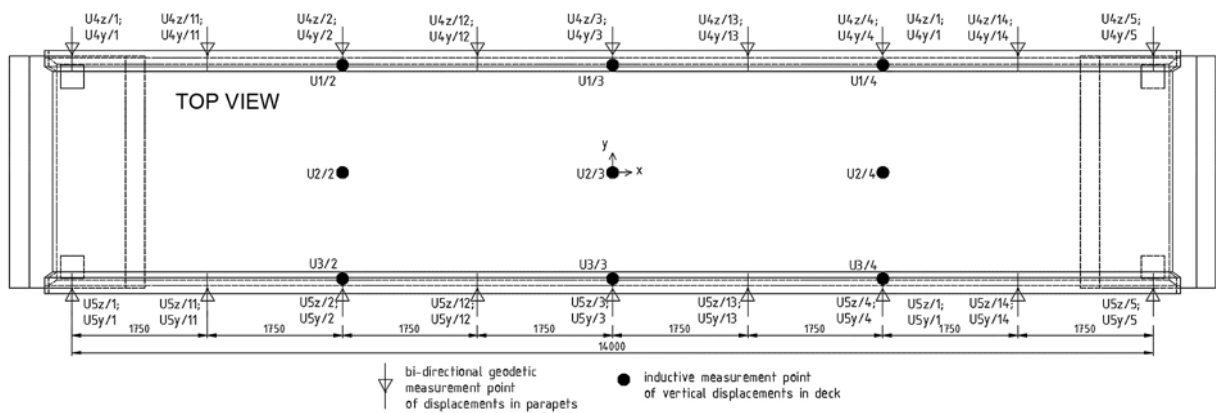

Figure 7. Location of geodesic and inductive displacement measurement points

It should be noted that the measurements at the selected, most exacted points of construction were verified using various measuring techniques. And so, while strain was measured using electric resistance gauges, vibrating wire extensometers and fibre-optic sensors and deformation by geodesic measurements and potentiometric linear displacement sensors. In addition, a modern laser scanner surveying technique was also used [16]. This implement was used to record the deformation of one of the bridge's walls.

As example results, strains at the measuring point T2x-3 - located in the centre of the bridge span, at lower part of the wall (see figure 6) and displacement at point U1 / 3, with location similar to the previous (see figure 7), are presented. Two settings with maximum ballast of 140 kN (figure 8) and 202 kN (figure 9) are cited. The graphs in each case display experimental data - lines and theoretical values - bars. The studies have shown a girder response several percent better than the one determined from the adopted structure calculation model. It should be noted that the calculation model by assumption does not take into account the additional resistance resulting from technological layers' load-bearing capacity (ribs), UV and anti-impact protection and irregular layers of resin absorbed in some of the contact surface pores, opened during treatments of the core foam contact surface. An example result of the laser scanner measurements is shown in figure 10.

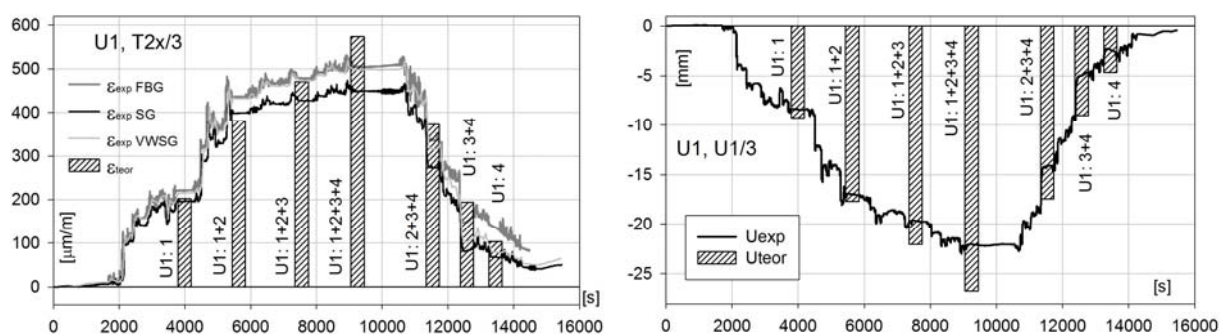

Figure 8. Strains at measurement point T2x-3 (left), displacement at U1/3 (right), ballast 140 kN

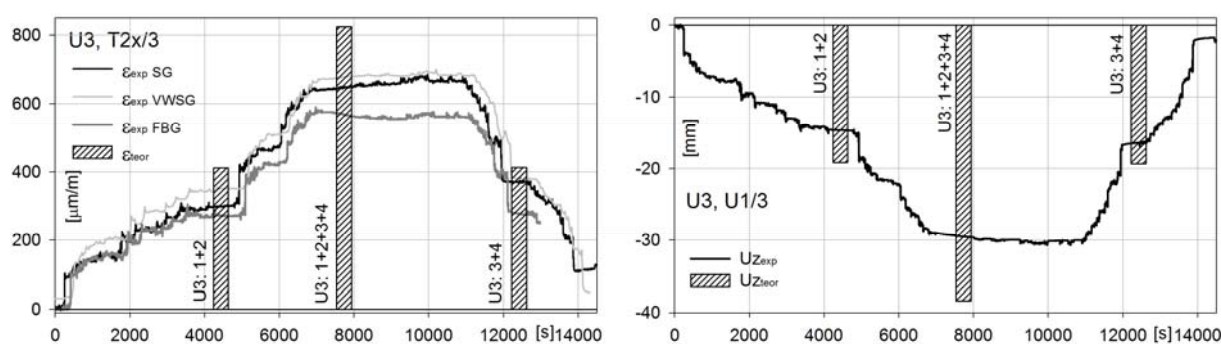

Figure 9. Strains at measurement point T2x-3 (left), displacement at U1/3 (right), ballast 202 kN

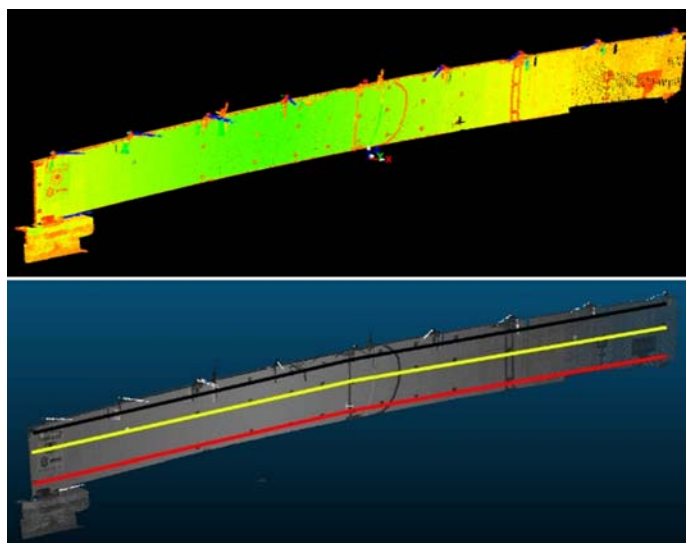

Figure 10. Results of laser scanning: image (top), preparation for analysis of the results (bottom)

6. Dynamic tests

Given the importance of the comfort parameter for pedestrian footbridges, dynamic testing of the object was carried out with great care. The following tests were included:

- tests corresponding to acceptance testing of footbridges with participation of a group of pedestrians, i.e.: walking, running and synchronous jumping (figure 11, left) in specific locations,
- modal hammer excitation (figure 11 right, 12 right),
- harmonic forcing with mass exciter,
- aggressive forcing.

During dynamic tests, the structure response was recorded at 99 measuring points:

- 24 strain measurement points (21 strain gauges, 3 fibre optic gauges),
- 9 inductive displacement measurement points,
- 48 sensor points for measurement of accelerations, including 18 monitoring system sensors and 30 fixed for the needs of test load (figure 12 left),
- 18 points of measurement of rotational speed.



Figure 11. Dynamic loads: jumping (left), modal hammer (right)

The research was carried out in three stages: pedestrian load (exploratory and aggressive), hammer excitations and using exciter on empty footbridge; and with hammer and exciter on ballasted footbridge. Example registered result of modal excitation is shown in figure 13. The result of impulse and harmonic tests was identification of dynamic footbridge parameters, i.e. natural frequencies, shapes of natural frequencies and damping numbers. Examples of the results are presented in table 1.

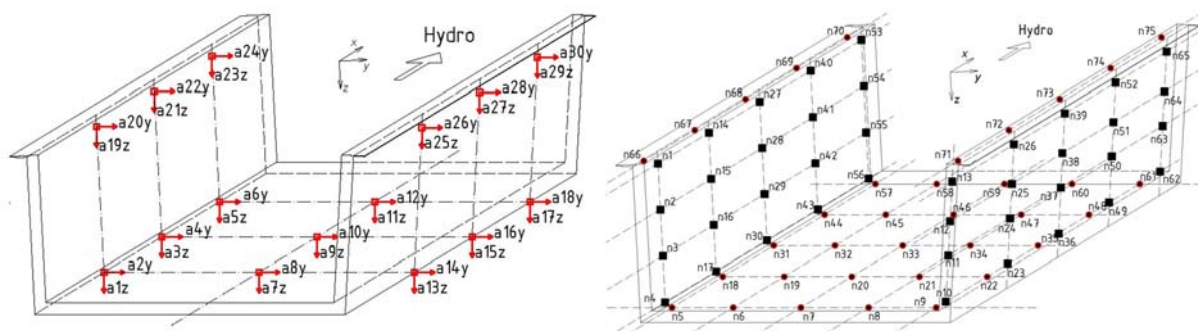

Figure 12. Localization of points for measurement of accelerations (left) and points of modal hammer and exciter excitations (right)

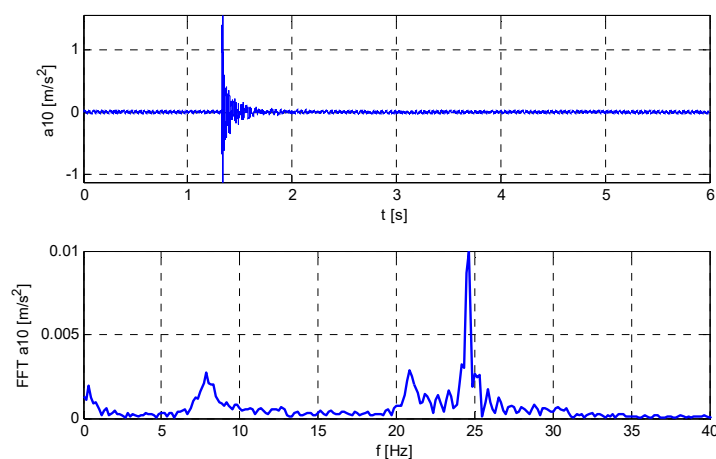

Figure 13. Example result of excitation with modal hammer

Table 1. Dynamic characteristics determined from the tests results.

Modal shape	Unloaded footbridge		Loaded footbridge	
	Frequency [Hz]	Damping ratio [%]	Frequency [Hz]	Damping ratio [%]
1	7.8	3.2	4.5	4
2	9.8	2.4	8.0	1
3	12.8	0.8	13.9	1.2

7. Conclusions

All tests performed on a full-size object confirm the correctness of assumptions made at footbridge design stage, and the behaviour of the 14-m variant displays even better qualities than expected. The experimentally confirmed structural capacity loads of the object, resulting from the additional strength of certain elements, the influence of which was omitted in the FEM calculations at design stage, will be usable during the realization stage. They will serve, among other things, to validate the numerical model.

The technical solutions adopted for the U-bridge allow for optimal use in span ranges of 12 - 18 m, while maintaining the construction height of 11 cm and only a few days' production process. It was estimated that the mass of the object should not exceed 4 t, even at a span of 18 m.

Acknowledgment

The study was supported by the National Centre for Research and Development, Poland, grant no. PBS1/B2/6/2013.

References

- [1] L. C. Bank, "Composites for construction - structural design with FRP materials," John Wiley & Sons, Inc., 2006.
- [2] J.R. Duflou, Y. Deng, K. Van Acker, and W. Dewulf, "Do fiber-reinforced polymer composites provide environmentally benign alternatives? A life-cycle-assessment-based study," *MRS Bulletin*, vol. 37, iss. 4, pp. 374-382, 2012.
- [3] M. W. Braestrup, "Footbridge constructed from glass-fibre-reinforced profiles, Denmark," *Structural Engineering International*, vol. 9, iss. 4, pp. 256-258, 1999.
- [4] J. Cadei, and T. Stratford, "The design, construction and in-service performance of the all-composite Aberfeldy footbridge," *Advanced Polymer Composites for Structural Applications in Construction*, 15-17 April 2002, Southampton, UK, pp. 445-453, 2002.
- [5] J. A. Sobrino, M. D. G. Pulido, "Towards advanced composite material footbridges," *Structural Engineering International*, vol. 12, iss. 2, pp. 84-86, 2002.
- [6] T. Keller, "Use of fibre reinforced polymers in bridge construction", *IABSE Structural Engineering Documents 7*, 2003.
- [7] P.J.D. Mendes, J.A.O. Barros, J.M. Sena-cruz, M. Taheri "Development of a pedestrian bridge with GFRP profiles and fiber reinforced self-compacting concrete deck," *Composite Structures*, vol. 93, pp. 2969–2982, 2011.
- [8] M. Areiza Hurtado, A. Bansal, C. Paulotto, and S. Primi: "FRP girder bridges: Lessons learned in Spain in the last decade," *Proceedings of the 6th International Conference on FRP Composites in Civil Engineering (CICE-6)*, Rome, Italy, 2012.
- [9] Y. Kitane, and A.J. Aref, "Fiber-reinforced polymer (FRP) composites for bridge superstructures", *Developments in Fiber-Reinforced Polymer (FRP) Composites for Civil Engineering*, pp. 347–381, 2013.
- [10] B. Stankiewicz, "Composite material GFRP and ductal in decks of bridge structures," *Journal of Materials Science and Engineering A*, vol. 4, pp. 282-289, 2014.
- [11] T. Siwowski, D. Kaleta, and M. Rajchel, "Design and research on the first polish FRP composite road bridge," *Romanian Journal of Transport Infrastructure*, vol. 4, iss. 2, pp. 62–74, 2016.
- [12] M. Miśkiewicz, R. Okraszewska, and Pyrzowski Ł., "Composite footbridge – synergy effect in cooperation between universities and industry," *ICERI2014: 7th International Conference of Education, Research and Innovation, ICERI Proceedings*, pp. 2897-2903, 2014.
- [13] Ł. Pyrzowski, B. Sobczyk, W. Witkowski, and J. Chróścielewski "Three-point bending test of sandwich beams supporting the GFRP footbridge design process - validation analysis," *Advances in Mechanics: Theoretical, Computational and Interdisciplinary Issues – Kleiber et al. (Eds)*, Taylor & Francis Group, London, pp. 489-492, 2016.
- [14] M. Miśkiewicz, K. Daszkiewicz, T. Ferenet, W. Witkowski, and J. Chróścielewski, "Experimental tests and numerical simulations of full scale composite sandwich segment of a foot- and cycle- bridge," *Advances in Mechanics: Theoretical, Computational and Interdisciplinary Issues – Kleiber et al. (Eds)*, Taylor & Francis Group, London, pp. 401-404, 2016.
- [15] M. Miśkiewicz, Ł. Pyrzowski, J. Chróścielewski, and K. Wilde, "Structural Health Monitoring of Composite Shell Footbridge for Its Design Validation," *Proceedings 2016 Baltic Geodetic Congress (Geomatics)*, pp. 228-233, 2016.

- [16] M. Bernat, A. Janowski, S. Rzepa, A. Sobieraj, and J. Szulwic, "Studies on the use of terrestrial laser scanning in the maintenance of buildings belonging to the cultural heritage," *14th Geoconference on Informatics, Geoinformatics and Remote Sensing, SGEM. ORG, Albena, Bulgaria*, vol. 3, pp. 307-318, 2014.