

## Mathematical Models in Design Process of Ship Bow Thrusters

A. Kopczyński\*

\*Gdańsk University of Technology, G. Narutowicza 11/12, 80-233 Gdańsk, Poland,  
E-mail: [andrzej.kopczynski@pg.gda.pl](mailto:andrzej.kopczynski@pg.gda.pl)

### Abstract

The paper describes an application of simulation models for computer-aided design of ship bow thrusters. Generation of simulation models of ship bow thruster requires development and verifying of mathematical models of system component elements. Using the results of simulation the expert system is able to determine, that the rules of classification societies are met. Design procedures and mathematical models are part of an expert system for computer aided design of ship power systems. As an example, the simulations investigation of the bow thrusters dynamics are presented. As a result of the research simulations, the plots of electrical supply, load current, load torque, and rotation speed of the induction motor are presented.

**KEY WORDS:** *thruster, mathematical model, simulation investigation, expert system, design process*

### 1. Introduction

Currently, mathematical models can be applied in many fields, also in a design process. Development of an adequate mathematical models is very labour-intensive and therefore expensive. Mathematical models should be properly evaluated and also easy to connect with another. The designers look for support at various stages of design to lower the costs and the use of artificial intelligence in design process helps to improve it. For these reasons, a library of mathematical models is developed. The models are used for the computer-aided design of a ship power system. The developed library contains mathematical models of elements of ship tunnel thrusters. The tunnel thrusters are installed in the bow or stern in order to improve docking, slow speed manoeuvring, emergency steering and station keeping at zero or slow forward speed. The manoeuvring of a ship using one single bow thruster are shown in the Fig. 1, where:  $x, y$  – coordinates of the ship position,  $V$  – ship speed,  $u, v$  – components vector,  $r$  – angular velocity of the ship turning,  $\psi$  – ship heading,  $\delta$  – rudder angle.

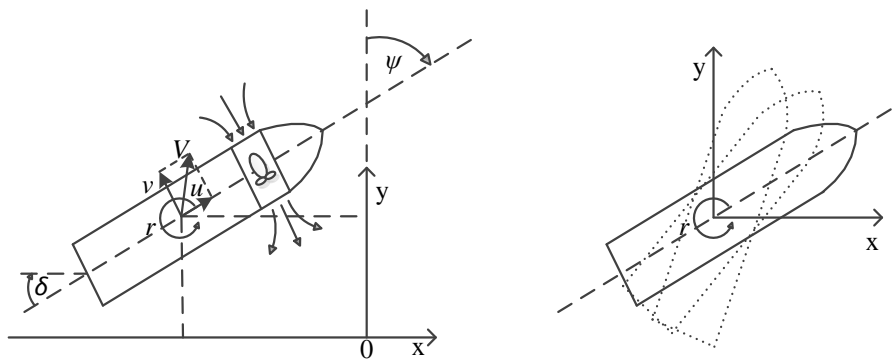

Fig. 1 Ship manoeuvring with use of bow thruster [6]

The library is used in an expert system to assist in the design of the ship thrusters. The simulations of bow thruster models were considered for the study of their impact on the power system of a ship. Works concerning computer-aided design systems are developing in the world. Earlier systems were mainly based on the use of the similarity to the earlier design solutions [9]. The developed hybrid expert system uses online simulation investigations as an additional source of knowledge [6]. Other authors proposed an application of multi-agent systems for ship's power system design [5]. The European Commission allocates significant resources to improve the competitiveness of the shipbuilding industry [8]. The Polish government also intends to support an industry related to a ship construction.

The paper describes the library of simulation models for computer-aided design of ship bow thrusters and an exemplary simulation investigation.

### 2. Library of Mathematical Models

The library includes models of the following elements: an induction motor (Fig. 2), a hybrid induction motor, an induction motor taking into consideration losses in an iron, the induction motor taking into consideration losses in a copper, a Diesel engine, a speed governor of the Diesel engine, a synchronous generator, a thyristor excitation system

and synchronous generator voltage controller, a propeller shaft (Fig. 3), a controllable pitch propeller (Fig. 4), a transmission gear adding moments, a transmission gear of a rotation speed, an electric load, and components with step changes of voltage: a star-delta switch, an autotransformer [1-3, 6].

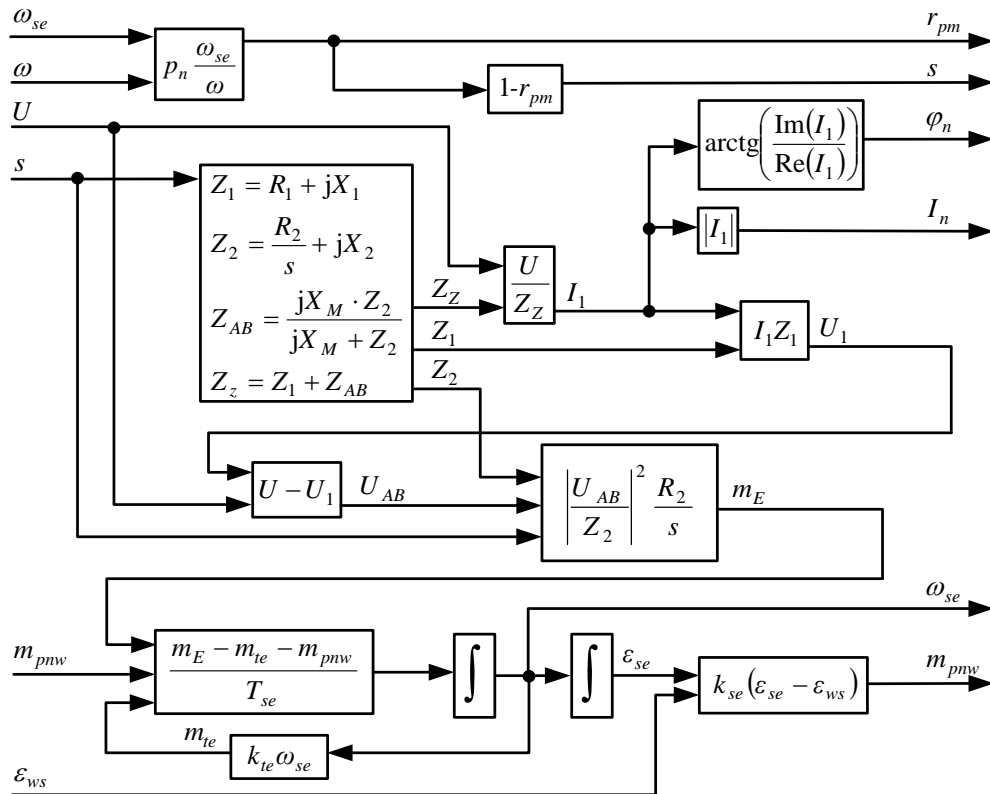

Fig. 2 Model structure of induction motor [6]

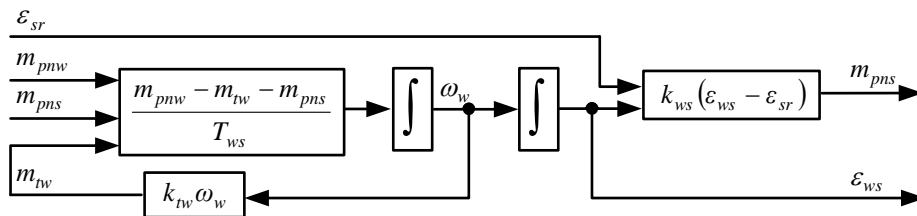

Fig. 3 Model structure of propeller shaft [6]

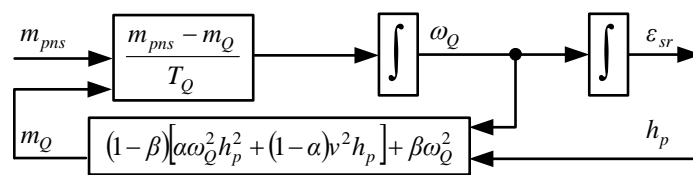

Fig. 4 Model structure of controllable-pitch propeller [6]

The library also contains the models parameters of chosen types of components elements.

The inputs and outputs of the model of an induction motor (Fig. 2) are:  $U$  - rms voltage of one phase,  $\omega$  - angular frequency,  $\varepsilon_{ws}$  - shaft angular distance,  $m_{pnw}$  - output torque,  $I_n$  - rms current of one phase,  $\varphi_n$  - phase shift of a load current.

The inputs and outputs of the model of a propeller shaft (Fig. 3) are:  $m_{pnw}$  - input torque,  $\varepsilon_{sr}$  - angular distance of a pitch,  $m_{pns}$  - output torque,  $\varepsilon_{ws}$  - angular distance of a shaft.

The inputs and outputs of the model of controllable - pitch propeller (Fig. 4) are:  $m_{pns}$  - input torque,  $h_p$  - given value of a pitch,  $v$  - ship speed,  $\varepsilon_{sr}$  - angular distance of a pitch.

The library of mathematical models was built in Matlab / Simulink environment, Using the developed structures of models we can easily transfer the library to other simulation applications. The developed models are used in an application of an expert system for aided design of ship power system automation.

### 3. Simulation Investigation of Ship Bow Structure

The simulation investigation of the bow thrusters will be presented as an example structure. Structure of the simulation model is shown in Fig. 5. The elements of the structure are: the Diesel engine, the speed governor of the Diesel engine, the synchronous generator, the thyristor excitation system and synchronous generator voltage controller, the induction motor (Fig. 2), the propeller shaft (Fig. 3), the controllable-pitch propeller (Fig. 4) [6, 7]. The bow thruster was simulated using the parameters equivalents to real elements. The parameters of the model of an induction motor are:  $p_n$  – number of pole pairs,  $R_1$  – stator resistance,  $R_2$  – rotor resistance,  $X_1$  – stator leakage reactance,  $X_2$  – rotor leakage reactance,  $X_M$  – magnetization reactance,  $k_{se}$  – torsional elasticity,  $k_{te}$  – gain factor of a friction torque,  $T_{se}$  – time constant of a rotating masses. The parameters of the model of a propeller shaft are:  $k_{ws}$  – torsional elasticity,  $T_{ws}$  – time constant of a rotating masses,  $k_{tw}$  – gain factor of a friction torque. The parameters of the model of a controllable-pitch propeller are  $\alpha$ ,  $\beta$  – factors of a controllable pitch propeller,  $T_Q$  – time constant of a rotating masses,  $V_{statku}$  – ship speed. These equivalent parameters are given in Tables 1-3. The parameters of mathematical models were chosen using genetic algorithms [4]. It was assumed that the screw for the  $h_p = 0$  gives resistance – 15% of the nominal load.

The established simulation investigations program is: the Diesel engine is started at time  $t = 0$  s, the voltage at the induction motor is switched on at the time  $t = 40$  s, the pitch propeller of bow thruster is set to 50% (maximum load) at time  $t = 60$  s, the pitch propeller of bow thruster is set to 100% (maximum load) at time  $t = 70$  s, the pitch propeller is set to the neutral position at time  $t = 80$  s, the time of the simulation is  $T_s = 100$  s.

Table 1

Model parameters for induction motor type AMA400L4A VAMH [4, 6]

$p_n$	$R_1$	$R_2$	$X_1$	$X_2$	$X_M$	$k_{se}$	$k_{te}$	$T_{se}$
1 pu	0,0469 pu	0,014 pu	0,1415 pu	0,0608 pu	2,6952 pu	$0,1 \cdot 10^6$ pu	0,02 pu	2 s

Table 2

Model parameters of propeller shaft type 1w [6]

$k_{ws}$	$T_{ws}$	$k_{tw}$
$8 \cdot 10^6$ pu	$1 \cdot 10^{-3}$ s	$1 \cdot 10^{-3}$ pu

Table 3

Model parameters of pitch propeller type 1s [6]

$\alpha$	$\beta$	$T_Q$	$V_{statku}$
0,8 pu	0,15 pu	0,09 pu	0 pu

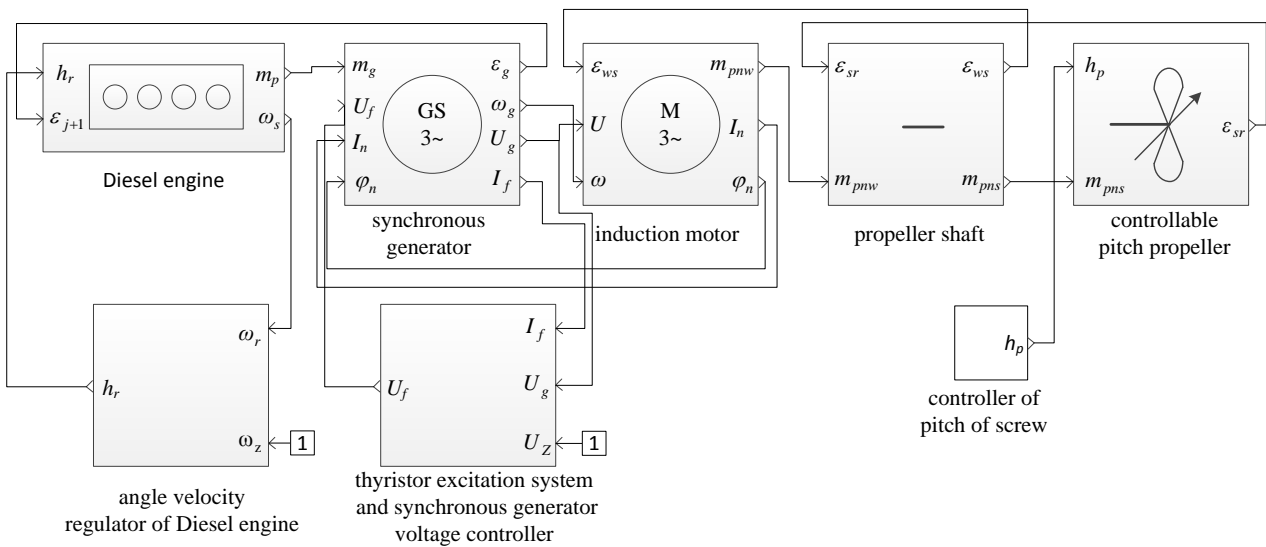

Fig. 5 Structure of mathematical model of bow thruster subsystem [7, 6]

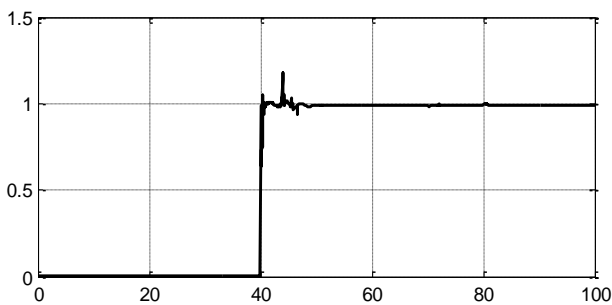

Fig. 6 Simulated voltage of induction motor. X-axis in seconds, Y-axis in relative values 1 = 100%

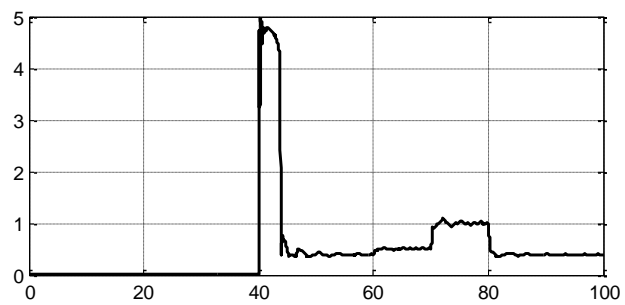

Fig. 7 Simulated current of induction motor. X-axis in seconds, Y-axis in relative values 1 = 100%

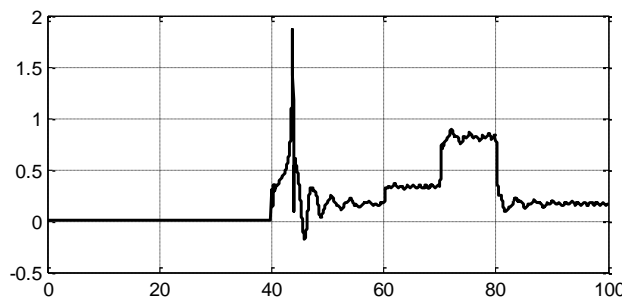

Fig. 8 Simulated load torque of induction motor.  
X-axis in seconds, Y-axis in relative values  
1 = 100%

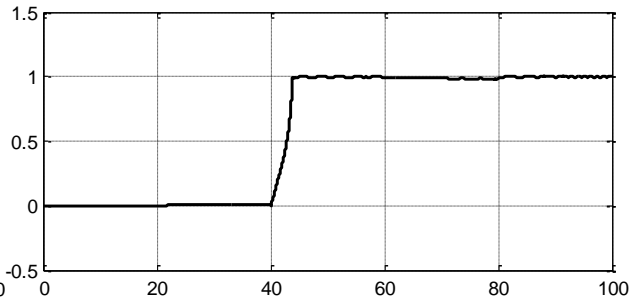

Fig. 9 Simulated angular velocity of induction motor.  
X-axis in seconds, Y-axis in relative values  
1 = 100%

As a result of simulation investigation plots shown in Figs. 6-9 were obtained. Figs. 6 shows the simulated value of voltage of the induction motor; the voltage drop is caused by current of the receiver. Fig. 7 show the simulated value of current of an induction motor; the increase of the current in the 40 s was caused by start of an induction motor.

The results of simulation investigations are compared with the requirements of classification societies. Fig. 8 show the simulated value of load torque of induction motor. Fig. 9 show the simulated angular velocity of induction motor. The angular velocity drop is caused by change of pitch given value. Using the simulation investigation results an expert system determines that the rules of classification society are met.

For example, the classification society PRS (Polish Register of Shipping) rule of a limitation of voltage changes of generator is that required limitation of voltage change – after  $t = 1.5$  s the voltage should be included in  $\pm 0.2 U_n$  is met.

#### 4. Conclusions

The library of mathematical models for the expert system was developed, on the basis of detailed analysis of design process of ship thrusters. The system includes:

- knowledge base containing methods and procedures of a ship system automation design;
- library of a ship thruster structure;
- database of a ship thruster elements;
- requirements of a classification societies,
- subsystem for online simulation investigation co-operating with the Matlab/Simulink environment.

Built system is characterized by a rule-oriented representation of knowledge, back-ward and forward chaining inference methods, and possibility of co-operation with other software and database. Database were made using the MS Access software. The described library of models is a part of the developed expert system. The results of simulation investigations are useful as an additional source of knowledge for the expert system. Because of the importance of the shipbuilding industry, the European Commission offers funds for supporting it. The built expert system application for the ship thrusters design, was verified with the use of on-line simulations on the project examples. Analysis of reports summarizing work of the system confirms the usefulness of the built tool as a means of support for designers.

#### References

1. **Arendt R.** Hierarchiczne modele hybrydowe systemu energetycznego statku o definiowanej strukturze. Wydawnictwo Politechniki Gdańskiej, Gdańsk 2006. ISBN 83-7348-019-6.
2. **Arendt R.** Modelowanie wpływu zasilania na pracę odbiorników systemu elektroenergetycznego statku. *Przegląd Elektrotechniczny*, 88 (2012), Nr04a, s. 141-146.
3. **Arendt R.** Wykorzystanie modeli systemu elektroenergetycznego statku. *Przegląd Elektrotechniczny*, 87 (2011), Nr8, s. 206-211.
4. **Arendt R., Kopczyński A., Wojtczak M.** The Choice of Parameters of Induction Motor Model Using a Genetic Algorithm. 10th IEEE IC MMAR, Międzyzdroje 2004 s. 149-154.
5. **Arendt R., Sychalski P.** An application of multi-agent system for ship's power systems design. - Proceedings of 20th International Conference. Transport Means, 2016
6. **Kopczyński A.** Analiza i projektowanie układów sterowania sterami strumieniowymi statków z zastosowaniem systemu z bazą wiedzy. Rozprawa doktorska, Gdańsk University of Technology, Gdańsk 2015.
7. **Kopczyński A.** Generowanie modeli symulacyjnych na potrzeby systemu ekspertowego wspomagającego projektowanie układów automatyki statku. - *Zeszyty Naukowe Wydziału Elektrotechniki i Automatyki Politechniki Gdańskiej*, Gdańsk 2015.
8. Community research and development information service of European Commission [online cit.: 2016-05-10]. Available from: [http://cordis.europa.eu/search/result\\_en?q=ship+design](http://cordis.europa.eu/search/result_en?q=ship+design)
9. Projekt ESDIS [online cit: 2016-05-30]. Available from: [http://www.cto.gda.pl/index.php?id=362&L=0&tx\\_cookiepolicybar\\_pi1\[action\]=close&tx\\_cookiepolicybar\\_pi1\[controller\]=CookieBar&cHash=f043a6b3babf4e7cdcec1a032307350e](http://www.cto.gda.pl/index.php?id=362&L=0&tx_cookiepolicybar_pi1[action]=close&tx_cookiepolicybar_pi1[controller]=CookieBar&cHash=f043a6b3babf4e7cdcec1a032307350e)