

NEW CONCEPT OF HYBRID PROPULSION WITH HYDROSTATIC GEAR FOR INLAND WATER TRANSPORT

Daniel Piątek
Gdansk University of Technology, Poland

ABSTRACT

The article presents the development of author's concept of a diesel/hydraulic propulsion system for inland watercraft. Due to specific nature of vessel navigation on rivers, classical propulsion systems with shaft lines can be effectively replaced by systems with hydraulic power transmission. A solution is also presented of a hybrid design with extra electric port having the form of a pumping system driven from a battery of accumulators. Strong and weak points of the proposed solution are discussed and its energy efficiency is assessed.

Keywords: inland water transport; propulsion system; hybrid propulsion; hydrostatic gear; energy efficiency

PROPULSION SYSTEM AND MANOEUVRABILITY OF INLAND VESSEL

The power source on a typical inland vessel (Fig. 1a) is a diesel engine which drives a fixed pitch propeller. In early solutions, for instance the pusher tug Nosorozec built in

the 1960s, it was a medium-speed engine (nominal speed: 500–750 rpm), while in more recent vessels, such as the pusher tug Bizon built in 1990s, high-speed engines were used (nominal speed: 1500–1800 rpm). The power transmission system consists of a single-stage reverse reduction gear with gear transmission ratio of up to 5.

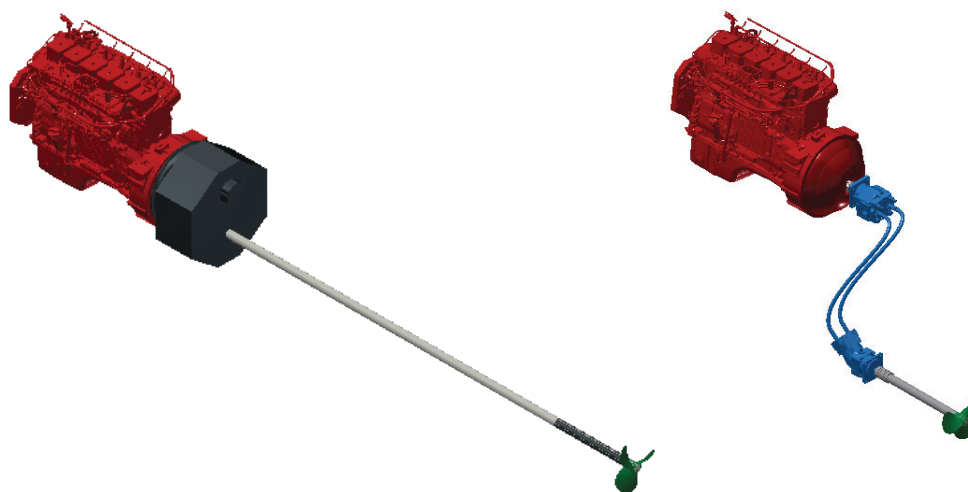

Fig. 1. Visualisation of inland vessel propulsion system (own elaboration)
a) System with shaft line and mechanical gear
b) System with hydrostatic gear

In the solution proposed by the author, the power transmission system comprises a so-called hydrostatic gear consisting of a pump, a hydraulic motor, and connecting hoses. The pump converts the mechanical energy of the internal combustion engine into the energy of the flowing liquid, which, in turn, is converted in the hydraulic motor into the mechanical energy needed for driving the screw propeller. To increase the energy efficiency of the proposed solution, the parameters of its operation are to be optimised. Increasing the operating pressure will lead to better power concentration, with the resulting smaller overall dimensions, mass, and inertia of the main system elements.

The energy efficiency can also be increased by changing rotational speed of the pump and hydraulic motor. The same pump driven by an internal combustion engine intended for use in the automotive industry (nominal speed 3000–4000 rpm) will generate twice as large a liquid flow, which will allow a further decrease of the overall dimensions. Compared to typical engines intended for use on inland vessels, the automotive engines are characterised by lower cost of purchase, which is, however, accompanied with higher specific fuel consumption.

Proper selection of geometric parameters of the hydraulic motor makes it possible to decrease the rotational speed of the propeller, and thus improve its efficiency. It is noteworthy, however, that this will lead to the increase of propeller diameter, which is considered unfavourable taking into

account rather small depth of rivers in Poland. Compared to a typical mechanical gear, the hydrostatic gear provides opportunities for reaching almost unlimited transmission ratio. Additionally, hydraulic power transmission eliminates a mechanical gear from the power transmission system, which minimises the risk of system failures resulting from propeller's contact with the river bed.

Within the low-speed engines, it is a group of satellite motors which reveal favourable parameters. Moreover, these motors can be supplied with water-based liquids, which is of certain importance for environment protection [1], [2], [3]. Frequently changing conditions of river navigation require numerous start-ups and low-temperature operation of the propulsion system [4], [5], [6].

The use of hydraulic gear makes it possible to shorten the motor compartment and easily distribute all propulsion system components, which is a great advantage when referring to inland watercraft.

Figure 2 shows the inland vessel propulsion and control structures which were selected for analysing mainly with respect to vessel manoeuvrability. This feature is very important for tourist vessels, which can be navigated by a low-experienced crew. It is noteworthy, however, that manoeuvrability improvement will be associated with the increase of system cost, and the final selection can only be made after proper financial analyses.

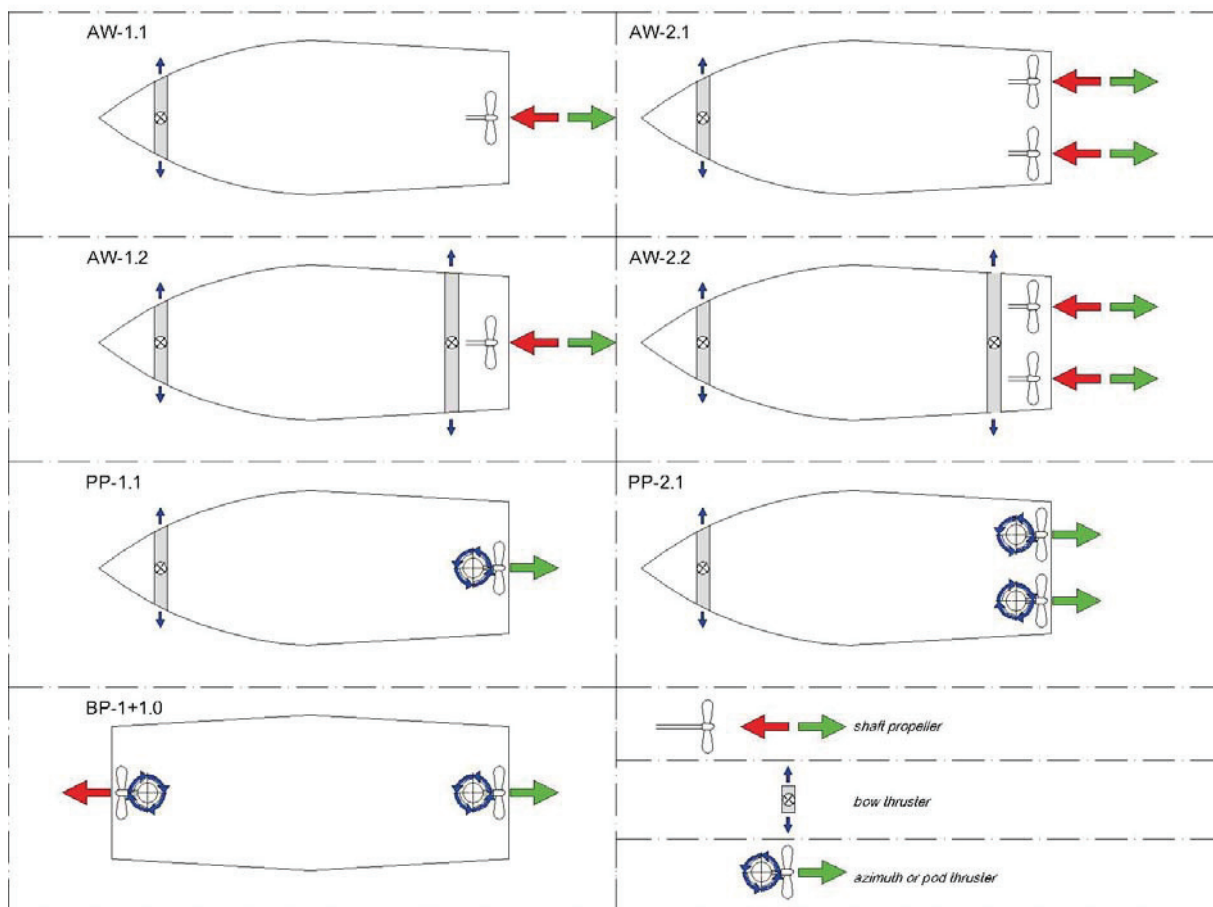

Fig. 2. Analysed structures of inland vessel control – description in the text (own elaboration)

DEVELOPING THE CONCEPT OF DIESEL/HYDRAULIC SYSTEM

The structure AW-1.1 is an adaptation of a system with classic shaft line in which the shaft line has been replaced with hydraulic gear. The direction of vessel motion is changed using a single-plate rudder (not shown in the figure), which results in poor manoeuvrability, especially at low speeds. The manoeuvrability can be improved by using a bow thruster with hydrostatic drive. The presented structure makes it possible to simplify the hydraulic system, to minimise its mass, and to maximise its energy efficiency. It is also easy for installation.

The structure AW-2.1 is almost identical with the previous one, with the use of two propellers instead one being the only difference. On a classic vessel, this will correspond with the use of two internal combustion engines. This modification increases the system construction cost, at the same time improving the safety of its operation and making it possible to obtain a torque by generating thrust forces in opposite directions (forward and backward).

The structures AW-1.2 and AW-2.2 result directly from the corresponding earlier systems, with the only difference consisting in the presence of an additional stern thruster. These structures allow the watercraft to be controlled easily and independently in longitudinal and transverse directions. A problem to be solved in this case is thruster location in the stern section of the hull. **The use of an additional stern thruster in the group of vessels selected for adaptation provides a reference manoeuvrability pattern.**

In the structure PP-1.1, the propeller and the single-plate rudder are replaced with a propeller/control device being an azimuth or nacelle propeller. This device increases the overall cost and requires interference into vessel's hull structure, but provides opportunities for smooth thrust generation within the 360° range, thus improving vessel's manoeuvrability.

The use of two rotatable thrusters (PP-2.1) which can rotate independently of each other provides good manoeuvring characteristics. Moreover, with the crew experienced in watercraft navigation, it makes it unnecessary to use a bow thruster.

The last structure BP-1+1.0 represents the vessel equipped with two rotatable thrusters (at bow and stern). This system allows the vessel to move in an arbitrary direction with respect to its axis. In this case, the bow thruster is exposed to the contact with the river bed or infrastructure, which can lead to its damage. However, the thruster can be protected against these unexpected contacts by proper design of bow hull section or the use of a catamaran type system.

The system of symmetric hull with two rotatable thrusters, at bow and stern, is an optimal solution for houseboat type watercraft from the point of view of its manoeuvrability.

For classic existing vessels, the form A seems to be most profitable, due to the smallest scope of the required adaptability work and the resulting low investment costs, which in this case mainly include the cost of hydraulic system purchase and installation.

There are ship design solutions in which extended hydrostatic systems are used for driving and supplying technological systems. A good example of such a solution is the fishing vessel KR-10 [7]. The propulsion system of this vessel comprises a traction motor which has been individually adapted for marine conditions. The above adaptation mainly consisted in adding a cooling system making use of salt water. The motor drives a variable-pitch propeller via a reduction gear and shaft line. This solution has rarely been used on small vessels. From the operational point of view, it makes it possible to change smoothly the thrust, regardless of motor revolutions, when operating the fishing trawl. The system of technological devices installed on the vessel, with trawl winch motors as main receivers, is powered from a constant delivery pump suspended on the main gearbox (PTO output – power take-off port). To reduce the cost of electrical installation, a decision was made to resign from ~220 V voltage and to use 24 V instead, together with hydraulic supply of larger receivers, such as fire pumps for instance.



Fig. 3. KR-10 fishing vessel: propulsion system with hydraulic drive of technological devices [7]

In years 2003–2006, the European Project Incowatrans was carried out which aimed at constructing a ferry for inland transport over Polish waterways on the route E-70 (Berlin-Kaliningrad). These waterways are characterised by low technical parameters (transit depth, length of locks, etc.) For these reasons, the constructed ferry consists of two

low-draught modules playing the role of hotel section and pusher tug, the latter driven by two diesel/hydraulic/electric units.

each circuit powered with an individual pump. The main drive is powered with a variable-delivery multi-piston axial pump working in closed circuit at working pressure $p = 32 \text{ MPa}$.

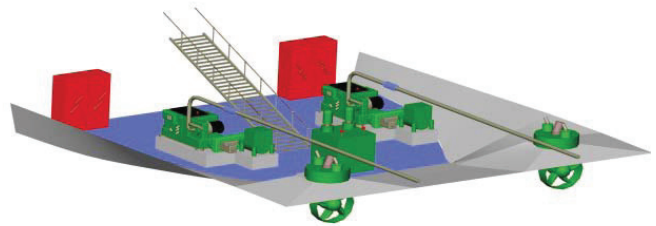
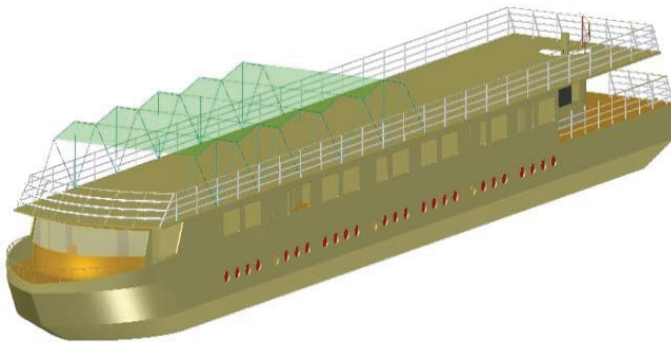

Fig. 4. Inland passenger ship Eureka – diesel/hydraulic drive, with rotatable hydraulic thrusters [8]

Each of two adapted internal combustion engines, which come from the automotive market, drives, via the main gearbox, a variable-delivery hydraulic pump and an electric generator. The hydraulic energy is used for driving two azimuth propellers with gearboxes in L-arrangement, which provides the vessel with good propulsion and manoeuvrability control, while the electric power is mainly consumed by passengers and crew. Depending on current needs, for instance upstream or downstream navigation, the contribution of particular types of energy in the internal combustion engine load can be changed smoothly.

The screw propeller is also driven with a typical multi-piston axial hydraulic system. This solution makes it possible to minimise the total mass of the used hydraulic components and to change smoothly propeller revolutions at constant rotational speed of the internal combustion engine. In the field of hydraulic drives, the applied components enable reaching the highest possible efficiency of the system at a relatively low investment cost.

The past experience gained by the author has made the basis for identifying the development trends in hydraulic power transmission systems on small vessels. These trends are collated in Fig. 6, with special focus on inland vessels. The bottom row indicates the solutions which are most desirable at the highest technological level:

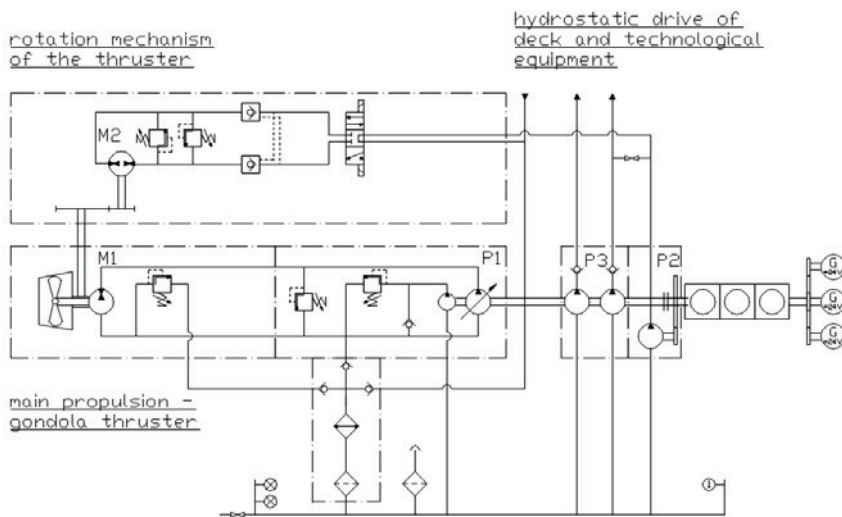

Fig. 5. Diesel-hydraulic propulsion of the vessel with hydraulic nacelle propeller [10], [11]

The essential component of the vessel propulsion system is a hydraulic nacelle propeller (Fig. 5). The hydraulic system is rather complex and consists of 3 functional circuits: main drive, propeller rotation drive, and drive for auxiliary devices,

- Diesel engine with rotational speed of 2800–3000 rpm, coming from the automotive industry and adapted for marine conditions and biogas feeding (due to easy CNG, LPG adaptation);
- Hybrid (diesel/electric) propulsion with hydraulic power transmission. The electric propulsion is used for navigation

in eco mode, with internal combustion engine switched off, and is powered from a battery of accumulators. The main high-pressure hydraulic propulsion, with nominal pressure of about 32 MPa, is generated by variable-delivery pumps in closed circuit;

- Nacelle propeller-based propulsion, with hydraulic motor(s) placed in a nacelle, performs the propulsion and control tasks.

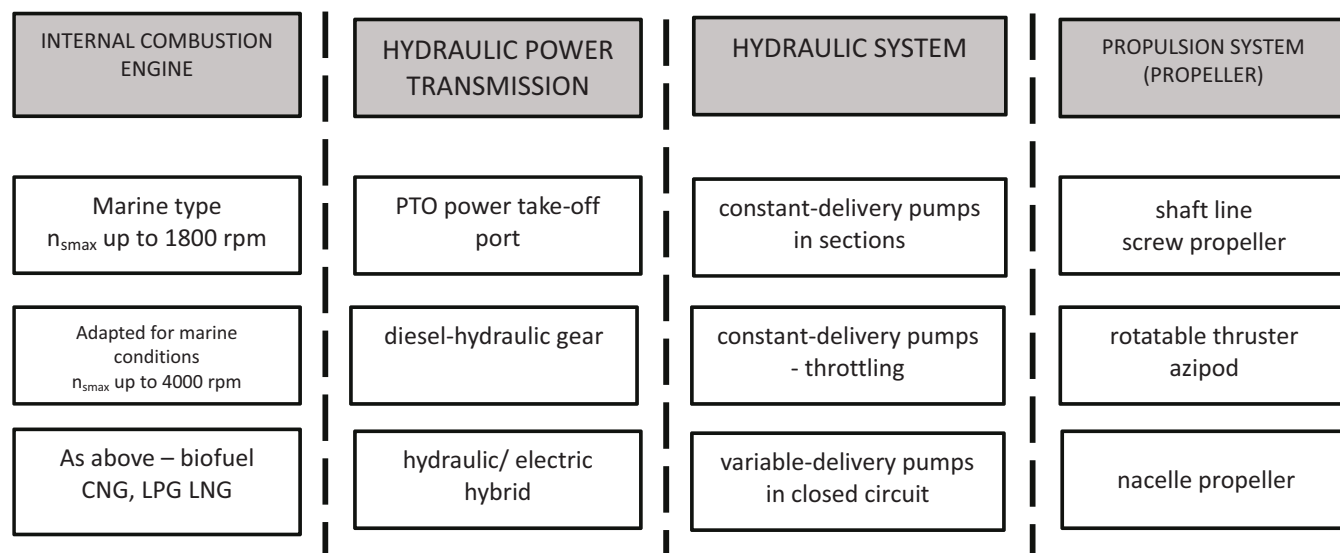

Fig. 6. Development in hydraulic power transmission systems on inland vessels [own elaboration]

We should be aware that due to a wide spectrum of vessels and investment cost criteria, the technically optimal solutions are not necessarily used on low-budget vessels.

MODULAR HYBRID DIESEL/ HYDRAULIC PROPULSION SYSTEM WITH ELECTRIC PORT

Fig. 7 shows concepts of hybrid diesel/electric propulsion systems with fully hydraulic power transmission. Concepts a) and b) in open circuit are intended for use on low-budget vessels with smaller power demand, such as the abovementioned houseboats, while version c) presents a system with variable-delivery pumps working in closed circuit, which is intended for use on inland vessels with highest power demand, for instance the abovementioned 250-kW IV-class pusher tugs.

During regular navigation, in all systems the internal combustion engine 1 drives the main pump 2, while when navigating in eco mode, with internal combustion engine switched off, in the zone of silence for instance, the propulsion role is taken over by the electric motor 8 which drives the eco pump 7 through valve blocks 11. Based on author's experience, the power of the eco pump has been selected as equal to 30% of nominal power of the main pump. Selection of fully hydraulic power transmission, even in eco mode, is motivated by a wish to use a hydraulic nacelle propeller 6 as the optimal propeller

for the vessel. However, including the eco pump to the system, and in particular recovery of energy needed for charging accumulators, makes the system structure more complex. Therefore, it is proposed to use the generator 10 suspended on the internal combustion engine.

The modular nature of the described solution results from the modularity of hydraulics with respect to the creation of multi-flow pumps, as a result of which a number of receivers

can be driven from one propulsion unit, without use of any mechanical gear (Fig. 5, for instance).

The proposed solution has all advantages of a hydraulic system. However, an issue which cannot be omitted is its competitiveness with rapidly developing systems with electric power transmission. Based on the performed analyses [9], electric systems do not have such serious advantages in marine applications as it is commonly believed. For a 300-kW vessel equipped with azimuth propellers, the hydraulic system is lighter by about 40 % than its electric equivalent, due to better power concentration. This is a very important parameter, as it affects the load capacity of a small vessel sailing on inland waters. The other parameter used in comparison is the investment cost, which has also turned out more profitable for hydraulic power transmission (77/100 ratio). This is mainly caused by the fact that a hydraulic system is constructed from typical components with certificates already issued by classification societies, while the electric transmission components can be licensed for operation in water environment only after making certain payments. Moreover, the main components of the electric transmission system and its control elements are frequently manufactured individually or in small series to custom order.

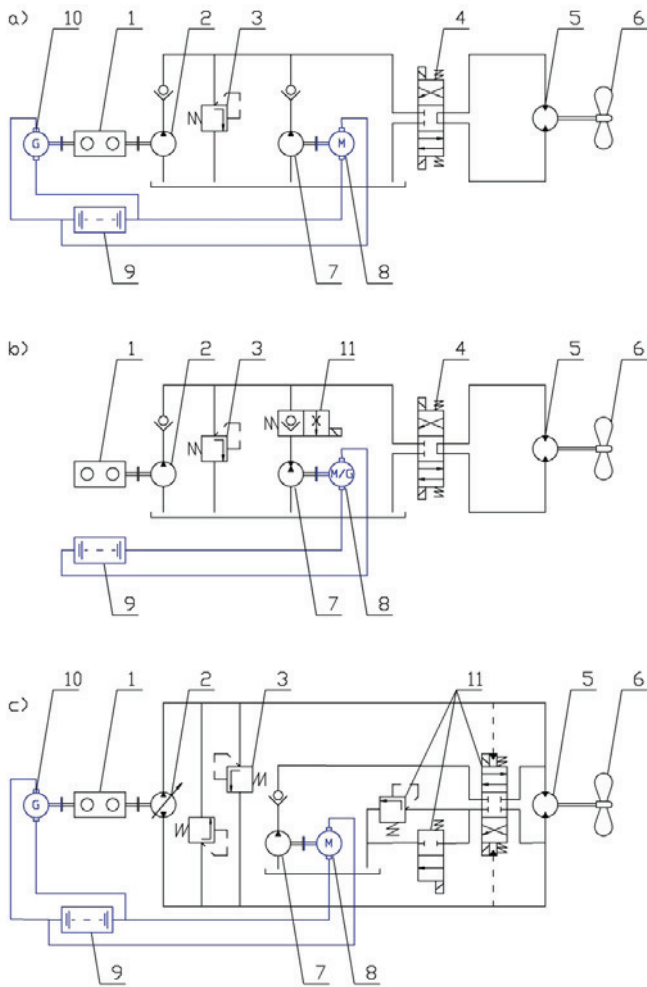

Fig. 7: Concept of diesel/electric system with hydraulic power transmission [own elaboration]:

- a) – open hydraulic circuit, charging accumulators from mechanical system;
 b) – open hydraulic circuit, charging accumulators from hydraulic system;
 c) – closed hydraulic circuit (accumulators charged from mechanical system);
 1 – internal combustion engine, 2 – main drive hydraulic pump, 3 – safety valve, 4 – divider controlling the direction of propeller revolutions (only open circuit); 5 – hydraulic propeller propulsion motor; 6 – propeller, 7 – eco pump with electric drive, 8 – motor driving the eco pump, 9 – battery of accumulators, 10 – electric generator with mechanical drive, 11 – eco pump switching unit (flushing function in closed circuit)

A basic criterion in the system performance evaluation is energy efficiency, i.e. losses generated during energy transmission. The author prefers determining the power flow direction in a system which is consistent with the increasing power demand from the receiver's side [12]. In this approach, the starting point is the power demand from the receivers, after which the system losses are to be assessed and complemented, and the final delivered power results from the total system demand. The above approach is consistent with the course of the design process.

The applied hydraulic transmission, which consists in double energy conversion (from mechanical to hydraulic energy in the pump and again to mechanical energy in the hydraulic motor), undoubtedly worsens the energy efficiency. Therefore, it is necessary to assess the range of this worsening

and decide whether it is acceptable, i.e. whether the energy efficiency decrease is sufficiently small to be compensated by the remaining advantages of the hydraulic power transmission.

Tables 1 and 2 collate the efficiency values of the propulsion system components shown in Fig. 1. They were assessed for the nominal point of system operation, based on the results of flue tests of propulsion systems with hydraulic power transmission (power of 40 and 90 kW). Due to the multidisciplinary nature of the issue, use was made of data presented in producers' catalogues and publications [13].

Tab. 1. Efficiency of components of the conventional system with shaft line

Name	Symbol	Value [-]
SCREW PROPELLER		
total efficiency of propeller	η_s	0,45
SHAFT LINE		
efficiency of shaft line	η_w	0,96
INTERNAL COMBUSTION ENGINE		
engine efficiency	η_D	0,35
PROPULSION SYSTEM with shaft line		
total efficiency	η	0,151

Tab. 2. Efficiency of components of the system with hydraulic power transmission

Name	Symbol	Value [-]
SCREW PROPELLER		
total efficiency of propeller	η_s	0,45
HYDROSTATIC GEAR		
efficiency of hydraulic power transmission	η_H	0,80
INTERNAL COMBUSTION ENGINE		
engine efficiency	η_D	0,35
PROPULSION SYSTEM with hydraulic power transmission		
total efficiency	η	0,126

When analysing the obtained results, we can see that the total efficiency of the propulsion systems on a small vessel is very low and does not exceed 20%. This rather surprising result is mainly caused by low efficiency of main system components (Fig. 8). Peculiar navigation conditions make that the propeller efficiency oscillates around 45%. The total efficiency of the internal combustion engine has been determined from individual tests performed by the author.

The shaft line efficiency takes into account losses in bearings and in the reduction gear, which in marine version has, as a rule, viscous clutches (gear loss of about 3–4%). The efficiency of the hydrostatic gear depends on the control structure and efficiency of individual components. For the analysed case, the efficiency of the multi-piston components was assumed as follows: pump $\eta_P=0,90$, hydraulic motor $\eta_M=0,92$, and hoses $\eta_C=0,97$.

The energy balances of the two analysed systems are given in Fig. 9. The efficiency difference between the shaft line and hydraulic power transmission is high and amounts to 16%.

However, low efficiency of the remaining components makes that the total efficiency difference is much smaller and only equals 2,5%.

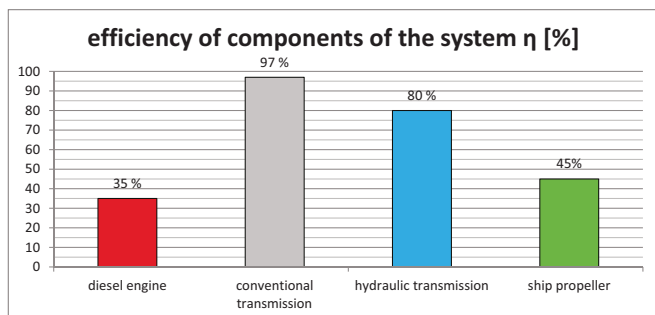

Fig. 8: Efficiency of main components of the propulsion system [own elaboration]

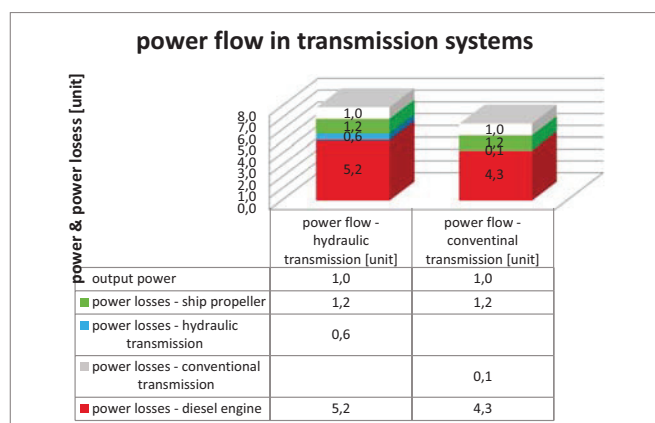

Fig. 9: Power loss distribution in systems with mechanical and hydraulic power transmission [own elaboration]

SUMMARY AND CONCLUSIONS

The article presents the results of studies upon possible use of hydraulic systems for driving vessels. The analysed systems can be used on fishing vessels and/or dredgers, for instance, where the demand for hydraulic energy is natural.

In inland navigation, the analysis of current condition of waterways in Poland and their development prospects resulting from government plans has made a basis for selecting a wide spectrum of vessels, starting from low-budget houseboats up to commercial pusher tugs, on which the use of hydraulic power transmission is clearly advantageous, as compared to the conventional shaft line system. These advantages include:

- full resignation from a rigid shaft line, which in conventional solutions determines the distribution of propulsion system components and occupies a place which otherwise would be used for extra cargo;
- arbitrary distribution of devices in the engine compartment inside the hull;

- smaller space required for propulsion devices inside the vessel – the engine compartment can be shortened;
- very good manoeuvring characteristics of the vessel when hydraulic nacelle propellers are used;
- full resignation from reduction gears, which are most sensitive propulsion system components in conventional solutions;
- one large internal combustion engine can be replaced by a number of smaller engines, with higher speed, to drive directly hydraulic pumps;
- a larger number of independent energy sources, with a possibility of their distribution in separate compartments, increases the reliability of the propulsion system and, consequently, the safety of navigation;
- the engine compartment does not have to be high, which provides a possibility for more effective use of valuable space on an inland vessel by situating the engine compartment in the least attractive section of the hull;
- lower hull vibrations caused by the work of engines driving propellers, with the resulting lower total noise level and higher comfort of navigation.

The above advantages are believed to fully compensate lower energy efficiency of systems with hydraulic power transmission.

The systems with hydraulic power transmission have high power concentration and can be based on typical components and subsystems. As a consequence, they usually have smaller mass and lower purchase price, compared to the presently developed electric propulsion systems.

The proposed concept makes it possible to adapt propulsion systems with hydraulic power transmission to legal regulations, which consist in introducing zones where the navigation of vessels with internal combustion engines is forbidden.

The research activities which are in progress now aim at:

- developing a concept of hybrid propulsion with hydraulic power transmission and preparing a real 40-kW system for field tests;
- working out a series and building a prototype of a hydraulic low-power nacelle propeller.

BIBLIOGRAPHY

1. Śliwiński, P.: Flow of liquid in flat gaps of the satellite motor working mechanism. Polish Maritime Research, Vol. 21, iss. S1 (82) (2014), s.50-57, DOI:10.2478/pomr-2014-001;
2. Śliwiński, P.: The influence of water and mineral oil on mechanical losses in the displacement pump for offshore and marine applications. Polish Maritime Research. Vol. 25, iss. S1 (97) (2018), s.178-188, DOI: 10.2478/pmr-2018-0040;
3. Śliwiński, P.: The influence of water and mineral oil on volumetric losses in a hydraulic motor. Polish Maritime Research Special Issue 2017 S1 (93) 2017 Vol. 24; s. 213-223 10.1515/pomr-2017-0041;

4. Jasiński R.: Problems of the starting and operating of hydraulic components and systems in low ambient temperature (Part III). Methods of determining parameters for correct start-ups of hydraulic components and systems in low ambient temperatures. Polish Maritime Research, Vol. 16, 4/2009;
5. Jasiński R.: Influence of design of hydraulic components on their operation in low ambient temperatures. Key Engineering Materials: Fundamentals of Machine Design, Vol. 490, 2012;
6. Jasiński R.: Problems of the starting and operating of hydraulic components and systems in low ambient temperature (Part V). Methods ensuring correct start-up of hydraulic components of ships onboard devices in low ambient temperatures. Polish Maritime Research, Vol. 24, Pages: 47-56, 4/2017;
7. Dymarski C.: Propulsion and control of a fishing vessel (in Polish). IX Seminar on Propulsion and control'2003, Fairs of Producers, Cooperants and Sellers of Propulsion Units and Control Systems (in Polish), Katowice 2003.
8. Dymarski C., Skorek G.: A design concept of main propulsion system with hydrostatic transmission gear for Island waterways ship. Polish Maritime Research, z. 2/2006.
9. Dymarski Cz., Rolbiecki R.: Comparative analysis of selected design variants of propulsion system for an inland waterways ship. Polish Maritime Research, 1(47)-2006.
10. Dymarski, Cz., Piątek, D.: Diesel/hydraulic propulsion system on a small fishing vessel (in Polish). Hydraulika i Pneumatyka. - 2012, nr 1, str. 19 -22;
11. Dymarski, Cz., Zagórski, M.: Azimuth POD propeller with hydraulic drive for a small vessel (in Polish). In: Tests, construction, production and operation of hydraulic systems (in Polish). Collective work edited by red. A. Klich, A. Kozieł, E. Palczak. Gliwice: KOMAG Institute of Mining Technology, 2011, S. 53 – 63;
12. Paszota, Z.: Energy losses in hydrostatic drive (...). Lambert Publications, 2016. ISBN - 978-36-596399-6-8;
13. Kulczyk, J., Winter, J.: Inland water transport (in Polish). Wrocław 2003, electronic version: http://www.dbc.wroc.pl/Content/1322/srodladowy_transport_wodny.pdf;

CONTACT WITH THE AUTHOR

Daniel Piątek

e-mail: freitag@pg.edu.pl

Gdansk University of Technology
 Faculty of Ocean Engineering and Ship Technology
 Narutowicza 11/12, 80-233 Gdańsk
POLAND

