

Noise in electrical double-layer capacitors (EDLCs)

Janusz Smulko
Faculty of Electronics,
Telecommunication and Informatics
Gdańsk University of Technology
Gdańsk, Poland
<http://orcid.org/0000-0003-1459-4199>

Arkadiusz Szewczyk
Faculty of Electronics,
Telecommunication and Informatics
Gdańsk University of Technology
Gdańsk, Poland
<https://orcid.org/0000-0002-9407-4064>

Łukasz Lentka
Faculty of Electronics,
Telecommunication and Informatics
Gdańsk University of Technology
Gdańsk, Poland
<https://orcid.org/0000-0001-7985-4356>

Abstract—We present methods and problems of noise measurements in electrical double-layer capacitors (EDLC). Detailed noise equivalent electronic circuit is considered, and two possible ways of observations of random processes generated in the EDLCs structures are studied. We conclude that noise is a useful tool for characterization of the EDLC structures and their state-of-health, as in other materials and electronic devices. Eventual, practical applications of noise measurements are proposed to determine the state-of-health of the EDLCs.

Keywords—electrical double-layer capacitor, flicker noise, white noise, state-of-health, reliability

I. INTRODUCTION

The ability to collect electrical energy is crucial for developing electric vehicles and other ecological equipment, requiring reliable and distributed power sources. The electrical double-layer capacitors (EDLC) may be used for this aim when fast delivery of energy has to be secured. These capacitors are also known by different names such as supercapacitors or ultra-capacitors. EDLCs are used to power mobile devices or to preserve energy produced by wind power stations because they are able to store a large amount of energy than that of ordinary capacitors and to supply the energy in a faster way than that of batteries, as presented by Ragon plot comparing different technologies of electrical energy storage systems [1], [2]. Unfortunately, the EDLCs are operating at low voltages and are very sensitive to any overvoltage or overheating [3]. Therefore, we have to monitor the processes in their structures to study the applied technology for its further development or to avoid damages of the applied elements.

The EDLC comprise of two porous carbon electrodes and electrolyte with a separator between these electrodes, protecting them from contacting (Fig. 1a). A charge is stored in an electrical double layer formed by applying a relatively low voltage to the terminals connecting the carbon electrodes. Ions are drawn to the surface of the electrical double layer of the EDLC when charged (Fig. 1b) and moved away when discharged. The EDLCs have a large active surface, due to the pores in the carbon of a diameter even of a few nm only. Such structure is very fragile and may lose its ability to charge collecting. Overheating or increased voltage accelerate the chemical reaction and result in pores blocking and reducing active charging area [4].

Noise is a well-known tool applied to assess state-of-health or reliability of the elements or systems. Flicker noise is observed in semiconductor devices, sensors, and electrochemical systems for this aim [5], [6]. It may also be used for the same aim for batteries [7], capacitors [8] and EDLCs as well [9]. A thorough review of low-frequency noise

sources existing in the electrode-electrolyte interface can be found elsewhere [10].

Noise measurements in EDLCs are not evident due to high capacitance and necessity of measurements in the low-frequency range, below 1 Hz. It means that the measurements require a long time of data acquisition, about a few hours, and stability to avoid any drifts induced by slow environmental changes like temperature. We consider these issues in the paper, and propose how to observe noise, and how to interpret the recorded data, and how to use it for a future practical application. Similar issues have been considered by others as well [11], [12].

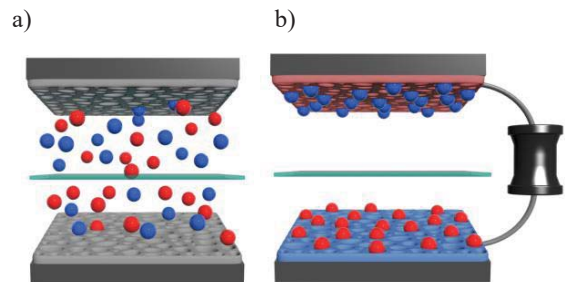

Fig. 1. Structure of the EDLC: a) discharged with the separator between the electrodes, b) charged with the separated positive and negative ions and attached loading resistor.

II. THE ELECTRICAL MODEL OF THE EDLCs

The porous structure of the carbon electrodes collects the charge when the ions move into the pores driven by an electric field. The electrical double layer is formed on a porous surface at the interface between the electrolyte and the carbon electrode. Thus, a state-of-health (SOH) of the EDLCs depend on the processes taking place in this small area. The SOH may be monitored by impedance spectroscopy, changes in capacitance and resistance or other EDLCs parameters [13], [14]. We may suppose that noise generated there sheds light on the smoothness of charging and discharging mechanisms. The pores may clog due to, e.g., ions disintegration which results in capacitance reduction. These processes may occur locally due to voltage or temperature distribution within the EDLC structure. We may suppose that the pores before clogging influence smoothness of charge movements and should modify noise level. Similar conclusions were reported for batteries elsewhere [6], [15]. The main problem of confirming this assumption is if the noise is sufficiently intense and may be observed by using the measurement set-up and how should be selected the conditions for the polarization of the investigated EDLCs during the measurements.

The equivalent circuit of the EDLC comprises of a ladder of resistances and capacitors, representing the processes of ions penetrating the pores. In general, the EDLCs may be modeled by a ladder circuit of at least two branches (Fig. 2) [6]. More detailed models of the EDLCs were proposed elsewhere [16], [17]. A thorough review of EDLCs modeling is presented in [18]. These models include new RC branches than presented in Fig. 2. We propose to focus on two branches only because it should be sufficient to model the dominant two physical phenomena. The first RC branch represents the process of charging and discharging which is relatively fast. The second RC branch represents the process of charge redistribution inside the EDLC structure which is much slower than charging and discharging process.

Capacitor C1 and resistor R_{ESR} represent the so-called Helmholtz capacitance with an equivalent series resistance (ESR) while capacitor C2 and resistor R_D represent processes induced by diffusion and present during charge redistribution [6]. Both capacitances, C1 and C2, have similar values. Additional resistor R_L represents a resistance responsible for a leakage current – the phenomenon of self-discharge. Resistance R_{ESR} is significantly lower than R_D , even about two orders of the magnitude. It means that C1 is charged to a specified voltage much faster than C2. The same remark is valid for discharging process. The difference in charging or discharging velocity means that we should be able to differentiate between noise sources related to both capacitances.

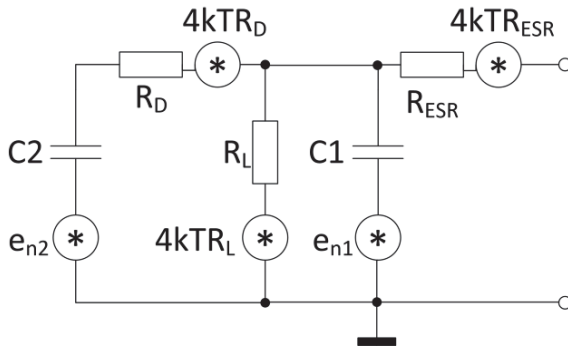

Fig. 2. Electrical equivalent circuit of the EDLC with voltage noise sources.

Noise generation in the EDLCs structures is related to ions migration in porous electrodes. Movements of ions within the pores of diameter even less than 1 nm take part in processes of electrical random signal generation. Electric field or diffusion phenomenon forces ions to penetrate the pores of the electrode material. Electric field may accelerate ions and energy dissipation is far from thermal equilibrium. The diffusion process is in thermal equilibrium, and the thermal noise sources may represent noise generated within the electrode-electrolyte interface. These two reasons (electric field or diffusion) should be responsible for the observed noise. Noise sources are exposed to the equivalent electrical circuit presented in Fig. 2. All voltage noise sources relate to the existing capacitances or resistors:

- C1, noise source e_{n1} ;
- C2, noise source e_{n2} ;
- R_D , thermal noise source $4kTR_D$;

R_{ESR} , thermal noise source $4kTR_{ESR}$;

R_L , thermal noise source $4kTR_L$.

All resistances are the sources of thermal noise, and at thermal equilibrium, their intensity is constant or changes due to alteration of these resistances (e.g., induced by EDLCs aging process). The noise sources e_{n1} and e_{n2} represent thermal noise of the capacitances C1, C2, and other additive noise, like shot noise (nonequilibrium fluctuations induced by charge transfer) or flicker noise (1/f-like noise) as well.

We may conclude that fluctuations are generated due to dissipative energy conductors and electrochemical interactions. When no current flows through the interface, the thermal equilibrium white noise dominates. Some low-frequency noise may be observed as well due to inherent noise of the measurement set-up and 1/f-noise of the RC elements of the electrical equivalent circuit of the EDLCs.

Local overheating or electrochemical reactions may block the pores and noise generated there should be very sensitive to this phenomena. The process of blocking pores modifies intensities of the noise sources e_{n1} and e_{n2} , which should be observed in the experiments. We may expect some changes in flicker noise as observed in various materials when changes in their structures induce a change of Hooge constant [19], [20]. This semi-experimental Hooge model of flicker noise generation by independent charges in the given bulk predicts such changes. We observed an increase of flicker noise intensity after aging in similar structures, the so-called smart windows, having nanoparticles electrode-electrolyte interface [21].

When we observe noise during the EDLCs discharging we may expect the shot noise component. Its power spectral density $S_i(f)$ depends on discharging current I and the ratio of the resistances, representing the charge transfer resistance R_c in the electrode-electrolyte interface and the bulk solution resistance R_b [10]:

$$S_i(f) = 2qI[R_c/(R_c + R_b)]^2 \quad (1)$$

where q is the electron charge. The intensity of shot noise may change when the ratio of the distinguished resistances evaluates during aging of the EDLCs. The presented eq. (1) is valid when the response time of the circuit between the terminals is much faster than the charge transfer and the kinetics of mass relocation within the electrode-electrolyte interface. In the opposite case, the proposed model of shot noise does not include the coefficient of the resistance ratio R_c and R_b [10]. In the first case, we may suppose that aging (e.g., by pores blocking) increases the resistance R_c and therefore change the intensity of shot noise component.

III. MEASUREMENT SET-UP

The measurement set-up for low-frequency noise observations in EDLCs consists of current/voltage source with galvanostatic/potentiostatic ability to assure the EDLCs charging/discharging process. Noise is recorded by using low noise amplifier and analog-to-digital 24-bits converter at different polarizing conditions to expose selected noise sources [9].

Two measurement procedures are proposed to expose two different noise sources. The first one requires charging with a constant current to the specified voltage. Next, the specimen

is discharged by loading resistor, and the voltage across this resistor is recorded. The voltage noise component is identified by subtracting exponential-like discharging curve (trend), as presented elsewhere [22]. This component is related mainly to charges stored in the capacitor C1 and only partially in C2 because the time constant $C1 \cdot R_{ESR}$ determines the discharging process. The second procedure requires again charging with a constant current to the given voltage. Next, the sample is short-circuited for a selected time after which the sample terminals are connected to the loading resistor and the voltage drop across this resistor is recorded due to charge migration from still partially charged C2 to C1. Noise component in the recorded time series is determined mainly by charge fluctuations in capacitance C2.

IV. EXPERIMENTAL RESULTS AND DISCUSSION

Two mentioned above measurement procedures were used to investigate the noise in the selected samples, produced by applying materials and methods similar to commercially available EDLCs. The samples had capacitances of about 10 F, and the specific method of their preparation was presented elsewhere [9].

The samples were aged by floating at 2.5 V. Noise was measured each time after a few hours of aging by floating. The noise was recorded during discharging the sample through the loading resistance $R = 100 \Omega$. Selected power spectral densities of voltage fluctuations across the loading resistance presents Fig. 3. We observed in the experiment:

- flicker noise at low-frequency range, usually below 1 Hz,
- the white noise of different intensities at frequencies higher than a few Hz.

Change of flicker noise intensity was somewhat limited, but other studies suggested that flicker noise may increase more during aging by floating than in the reported experiment. We suppose that this change of flicker noise level may be induced by pores blocking or local overheating and delamination between the metal collector and porous carbon electrode.

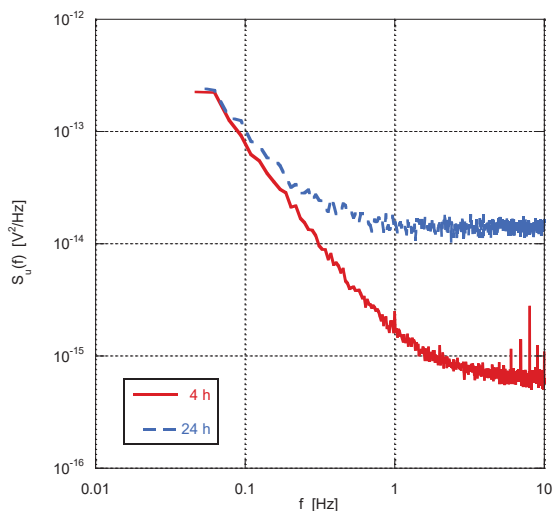

Fig. 3. Power spectral density $S_u(f)$ of voltage fluctuations observed across the loading resistance $R = 100 \Omega$ versus frequency f during discharging the sample JP12.1: after 4 h (solid line) and after 24 h (dotted line) of aging by floating at 2.5 V.

More intense noise change was observed in the white noise region. After aging, shot noise increased more than tenfold times. Rapid noise increase was observed after about ten hours of aging. More intense noise preserved in the next stages of aging with some variations. This effect may be explained by an increase of the resistance R_c in an electrode-electrolyte interface and as a result the change of the fraction $R_c/(R_c + R_b)$ in the eq. (1). An increase of noise intensity about ten times means that R_c and R_b should change respectively to result in a change of shot noise intensity. Although we don't know the exact values of both resistances R_c and R_b we should expect that noise measurements allow shedding light on the relation between these resistances and further assess the state-of-health of the electrode-electrolyte interface, and the tested EDLC in general.

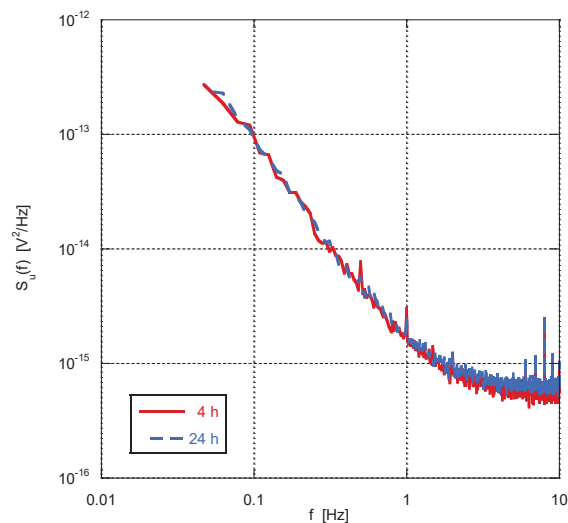

Fig. 4. Power spectral density $S_u(f)$ of voltage fluctuations observed across the loading resistance $R = 100 \Omega$ versus frequency f when the sample JP12.1 was discharged by a constant current $I = 650 \text{ mA/g}$ to 0 V and next short-circuited for 2 h, followed by attaching the loading resistance R to the terminals before noise measurements. Voltage fluctuations were recorded after 4 h (solid line) and after 24 h (dotted line) of aging by floating at 2.5 V.

The second method of noise observation was applied when the sample was discharged – the charge collected in the capacitance C1 was removed, but some charge was still preserved inside the capacitance C2 (Fig. 2). After discharging and short-circuiting for 2 h, the loading resistor $R = 100 \Omega$ was attached to the terminals of the investigated EDLC. Then, the capacitance C2 charged C1 slowly and generated a voltage between the terminals of the EDLC. We observed that the voltage between the terminals slowly increased reaching the maximum value over a dozen mV after about 15 min. from the moment of attaching the loading resistor R . Then, we measured voltage fluctuations and determined their power spectral densities after the trend removal procedure. Power spectral densities $S_u(f)$ of voltage noise across the resistor R are shown in Fig. 4. The intensity of $S_u(f)$ changed slightly after aging at the white noise region only. We may conclude that the aging process does not affect the capacitance C2 and therefore we don't observe changes in noise level.

We should underline that noise measurements of the EDLCs require a few hours of voltage time series recording in both applied methods. Moreover, noise intensity is relatively low and requires low-noise measurement set-up which may

limit future applications of the proposed method to monitor a SOH of the EDLCs.

V. CONCLUSIONS

We propose an electrical noise circuit of the EDLC which explains the results of our experimental studies. Moreover, selected problems of noise measurements in the EDLCs are presented. Measurement results were considered to point out future practical applications for their SOH evaluation.

We conclude that noise may be used to assess the state of the electrode-electrolyte interface. Any changes within this area determine the intensity of shot noise, which was confirmed by our measurement results. Additionally, some changes in flicker noise may also be present but of lower intensity than for shot noise. We argue that noise measurements may be utilized in practice for the EDLCs assessment.

ACKNOWLEDGMENT

This research was financed by the National Science Center, Poland, project No. DEC-2014/15/B/ST4/04957, "Charging/discharging mechanism at the electrode/electrolyte interface of supercapacitors".

REFERENCES

- [1] D. Ragone, "Review of battery systems for electrically powered vehicles," 1968.
- [2] M. Winter and R. J. Brodd, "What Are Batteries, Fuel Cells, and Supercapacitors?," *Chem. Rev.*, 2004.
- [3] H. Gualous *et al.*, "Supercapacitor ageing at constant temperature and constant voltage and thermal shock," in *Microelectronics Reliability*, 2010.
- [4] A. El Mejdoubi, H. Chaoui, J. Sabor, and H. Gualous, "Remaining Useful Life Prognosis of Supercapacitors under Temperature and Voltage Aging Conditions," *IEEE Trans. Ind. Electron.*, vol. 65, no. 5, 2018.
- [5] L. K. J. Vandamme, "Noise as a Diagnostic Tool for Quality and Reliability of Electronic Devices," *IEEE Trans. Electron Devices*, vol. 41, no. 11, pp. 2176–2187, 1994.
- [6] E. A. Astafev, "Electrochemical noise measurement of a Li/SOCl₂ primary battery," *J. Solid State Electrochem.*, vol. 22, no. 11, pp. 3569–3577, Nov. 2018.
- [7] E. A. Astafev, A. E. Ukshe, and Y. A. Dobrovolsky, "Measurement of electrochemical noise of a Li/MnO₂ primary lithium battery," *J. Solid State Electrochem.*, vol. 22, no. 11, pp. 3597–3606, Nov. 2018.
- [8] A. Konczakowska, "1/f noise of electrolytic capacitors as a reliability indicator," *Qual. Reliab. Eng. Int.*, vol. 14, no. 2, pp. 83–85, Mar. 1998.
- [9] A. Szewczyk, Ł. Lentka, J. Smulko, P. Babuchowska, and F. Béguin, "Measurements of flicker noise in supercapacitor cells," in *2017 International Conference on Noise and Fluctuations, ICNF 2017*, 2017.
- [10] A. Hassibi, R. Navid, R. D.-J. of applied physics, and undefined 2004, "Comprehensive study of noise processes in electrode electrolyte interfaces," *J. Applied Physics*, vol. 96, no. 2, pp. 1074–1082.
- [11] E. A. Astafev, "Software and Instrumentational Methods of Enhancing the Resolution in Electrochemical Noise Measurements," *Russ. J. Electrochem.*, vol. 54, no. 11, pp. 1031–1044, 2019.
- [12] S. Martemianov, N. Adiantov, Y. K. Evdokimov, L. Madier, F. Maillard, and A. Thomas, "New methodology of electrochemical noise analysis and applications for commercial Li-ion batteries," *J. Solid State Electrochem.*, vol. 19, no. 9, pp. 2803–2810, Sep. 2015.
- [13] H. Chaoui and H. Gualous, "Online Lifetime Estimation of Supercapacitors," *IEEE Trans. Power Electron.*, vol. 32, no. 9, 2017.
- [14] A. Oukaour, B. Tala-Ighil, M. AlSakka, H. Gualous, R. Gallay, and B. Boudart, "Calendar ageing and health diagnosis of supercapacitor," *Electr. Power Syst. Res.*, vol. 95, pp. 330–338, 2013.
- [15] D. Wang, F. Yang, Y. Zhao, and K.-L. Tsui, "Prognostics of Lithium-ion batteries based on state space modeling with heterogeneous noise variances," *Microelectron. Reliab.*, vol. 75, pp. 1–8, Aug. 2017.
- [16] L. Zubieta and R. Bonert, "Characterization of double-layer capacitors for power electronics applications," *IEEE Trans. Ind. Appl.*, vol. 36, no. 1, pp. 199–205, 2000.
- [17] V. Sedlakova *et al.*, "Supercapacitor equivalent electrical circuit model based on charges redistribution by diffusion," *J. Power Sources*, vol. 286, pp. 58–65, Jul. 2015.
- [18] Z. M. Zhang *et al.*, "An intelligent background-correction algorithm for highly fluorescent samples in Raman spectroscopy," *J. Raman Spectrosc.*, vol. 41, no. 6, pp. 659–669, 2010.
- [19] F. N. Hooge, "1/f noise sources," *IEEE Trans. Electron Devices*, vol. 41, no. 11, pp. 1926–1935, 1994.
- [20] L. K. J. Vandamme, "Noise as a diagnostic tool for quality and reliability of electronic devices," *IEEE Trans. Electron Devices*, vol. 41, no. 11, pp. 2176–2187, 1994.
- [21] J. Smulko, A. Azens, L. Kish, and C. G. Granqvist, "Quality assessments of electrochromic devices: the possible use of 1/f current noise," *Ionics*, vol. 13, no. 3, pp. 179–182, 2007.
- [22] Ł. Lentka and J. Smulko, "Methods of trend removal in electrochemical noise data – Overview," *Meas. J. Int. Meas. Confed.*, vol. 131, 2019.

