

# NUMERICAL SIMULATION OF BEHAVIOUR OF THIN-WALLED FRAMES SUBJECTED TO STATIC LOADS

MARCIN KUJAWA, TOMASZ MIKULSKI  
AND CZESŁAW SZYMCZAK

*Faculty of Civil Engineering, Gdansk University of Technology,  
Narutowicza 11/12, 80-952 Gdansk, Poland  
{markuj,tomi,szymcze}@pg.gda.pl*

(Received 26 April 2002)

**Abstract:** In this paper we are discussing the problem of behaviour of frames composed of thin-walled members with bisymmetric open cross-section. We present results of computer simulations of behaviour of the frame subjected to torsional loads. The main problem of the simulation is bimoment distribution in the frame node. The new approach using the node superelement is proposed to carry out static analysis of the frame. Numerical examples of the frame analysis subjected to a torque are given.

**Keywords:** frame, thin-walled members

## 1. Introduction

Frames composed of thin-walled members are very often used in civil engineering structures, in shipbuilding industry as well as in various machines and vehicles. Therefore the study of proper methods of mathematical modelling of these structures is of great importance for simulations of their behaviour. Every real structure of this type is subjected to torsional loads that produces warping of member cross-section. If we model a thin-walled frame by one-dimensional classical thin-walled beam elements, then to describe its behaviour we can assume that the elements possess non-deformable cross sections [1]. However, due to presence of torsion of beam elements bimoments arise thus, it is necessary to solve the problem of bimoments distribution in the frame nodes. Because the bimoments constitute self-equilibrated force systems, therefore the available static equilibrium equations will be always satisfied regardless of the bimoment magnitudes. On the other hand, as it follows from the recent research findings, the nodal bimoments distribution depends fundamentally on the layout and dimensions of elements in the nodes. In the literature and engineering practice there are various concepts of establishing the bimoments distribution [2-5], but none of them gives the general solution to this problem. In the present study we propose the approach based on FEM, consisting in the use of a nodal superelement. In this way

the essential role of the frame nodes in the frame behaviour can be accounted for, as it has already been suggested in [6], where the authors comment on the necessity of taking into consideration the deformation of the element cross-section, especially in the nodal zones. The scope of this paper is limited to the frames composed of thin-walled members with the bisymmetrical open cross-section.

## 2. Formulation and solution method of the problem

Let us consider the frame consisting of thin-walled members with the bisymmetric open cross-section presented in Figure 1. The frame is subjected to a static load causing the torsion on its members.

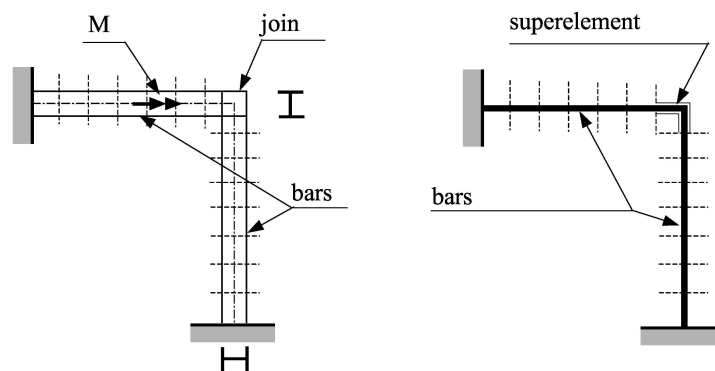

**Figure 1.** Frame assembled with the thin-walled members of the bisymmetric open cross-section

The basic problem in the simulation of the frame behaviour is the bimoment distribution at the frame node. In the present research we propose to model the frame by finite elements as follows:

- in the region between nodes by thin-walled elements based on the classical assumptions of the theory of thin-walled beams of non-deformable cross-section [1],
- in the region of nodes – by superelements composed of the flat shell elements. The superelement stiffness matrix can be determined with the aid of the NASTRAN software package, by treating nodal zone as a complex system of plates divided into a large number of CQUAD4 shell elements (Figure 1).

In this way we may take into account the effect of all details of the node construction that will be reflected in the stiffness matrix of the nodal superelement, which, as we believe, will lead to more accurate numerical response of the frame. At the same time we automatically take into consideration also possible distortion of the member cross-sections in the nodal zone, as it is suggested in [6]. The results of numerical simulation, obtained for the frame model described above, are compared with the results of the most exact model, in which the whole frame is represented by an assemblage of flat shell finite elements (NASTRAN CQUAD4 shell elements). The frame assembled with thin-walled members is taken into consideration. In this model the deformations of nodal zones are neglected and the member behaviour is described in accordance to the theory of beams with non-deformable cross-section.

### 3. Numerical examples

Let us consider a plane frame consisting of the thin-walled I-members (Figure 1). The frame is subjected to torque  $M = 1 \text{ kNm}$  at the mid-span cross-section as shown in Figure 1. The distributions of internal forces are determined for four types of the member-to-node connections as follows:

1. fully hinged joint (of nodal bimoments equal to zero),
2. fully fixed joint (of nodal distortions equal to zero),
3. the distribution of bimoments in a node is proportional to the member warping stiffnesses,
4. rigid connection at the assumption of redundant forces at end sections as presented in Figures 2a and 2b.

The values of bimoments in the element end cross-sections A, B, C, and D for all investigated models of the frame are given in Table 1.

**Table 1.** Values of the element end bimoments for models of the frame under consideration

	A-A	B-B	C-C	D-D
Method 1	-0.6396	0	0	0
Method 2	-0.4554	-0.4554	0	0
Method 3	-0.4050	-0.2280	0.2280	0.0504
Method 4a	-0.3670	-0.0260	0.0380	0.0190
Method 4b	-0.3880	-0.1090	0.0750	0.0170
Method 5	-0.6380	-0.1610	0.2190	-0.1010

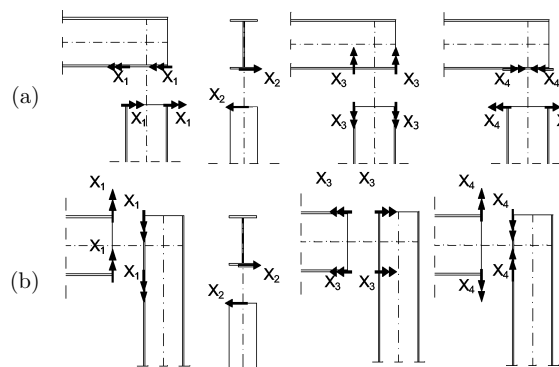

**Figure 2.** The redundant forces in nodal cross-section: (a) horizontal, (b) vertical

For comparison purposes we quote also the results obtained for the response simulation of the whole frame modelled by shell CQUAD4 elements and the NAS-TRAN software (Method No. 5). The mesh of elements used is shown in Figure 3. The comparison of results clearly shows that there are significant differences between the considered methods of modelling of the tested frame. So far, none of the analysed models gave the results similar enough to the results of the most exact model (FEM model for whole frame – Method No. 5).

Hence the proposition to develop a new model of the structure, based on the concept discussed in Chapter 2 and illustrated in a sketch form in Figure 1. The frame

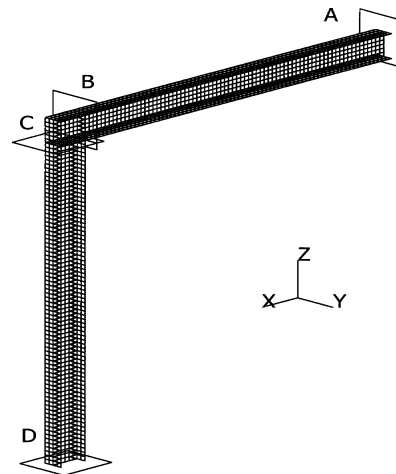

**Figure 3.** The frame element mesh for FEM model (NASTRAN software)

nodes will be treated as superelements modelled separately by flat shell elements. The superelement stiffness matrix is referred to the displacements of all one-dimensional thin-walled beam elements of the non-deformable cross-section that interface at the node. In this way the superelement stiffness matrix connects the node to the frame members composed of thin-walled beam elements. It is worth to mention that within the scope of this model we are taking into account the essential effect of the structure deformation at the nodal zones. The four different variants of the node construction are considered (Figure 4). The nodal stiffness matrix has already been calculated by using the method of unit displacements. Figures 5 and 6 show stress fields in the frame node due to unit rotation loads for one of the four types of the node constructions.

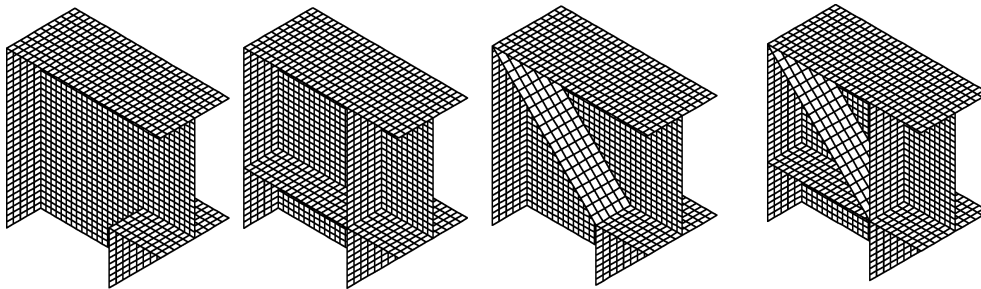

**Figure 4.** Types of frame node construction and the assumed mesh of FEM elements

Finally we present the results of the static analysis of the frame carried out by means of the superelements method proposed. Three distributions the rotation angle of cross-section resulting in different kind of solution, *i.e.* classical, superelement method and FEM, for the whole structure are shown in Figure 7 separately for both parts of the frame.

#### 4. Conclusion

The comparison study of five different methods of modelling the effects of a finite size node in the simulation of the behaviour of a thin-walled frame, has

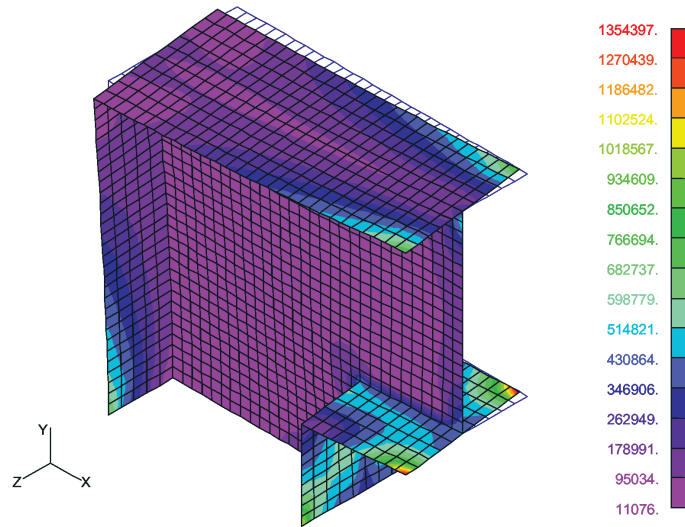

Figure 5. Plot of stress field in the frame node due to the unit rotation along X-axis

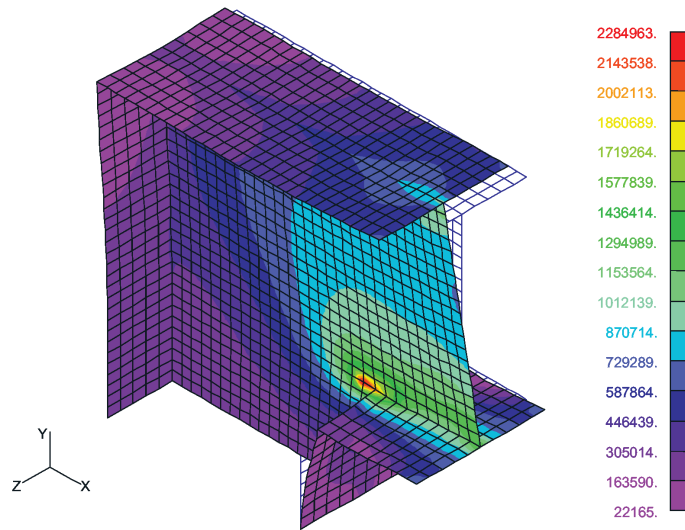

Figure 6. Plot of stress field in the frame node due to the unit rotation along Z-axis

shown the essential differences in the internal forces obtained for particular models. This observation points out the necessity to develop a new, more exact method, that would take into account the effects of the node construction on the state of internal forces and especially bimoments. We have proposed in this paper a frame model that is based on the use of a nodal superelement together with the thin-walled beam elements of non-deformable cross-section. The concept of the nodal superelement will allow us to take into account, in the analysis of the structure, the effects of node layout using the model that is much easier than the model of the whole frame divided into flat shell elements. The nodal stiffness matrix has been calculated using the method of unit displacements.

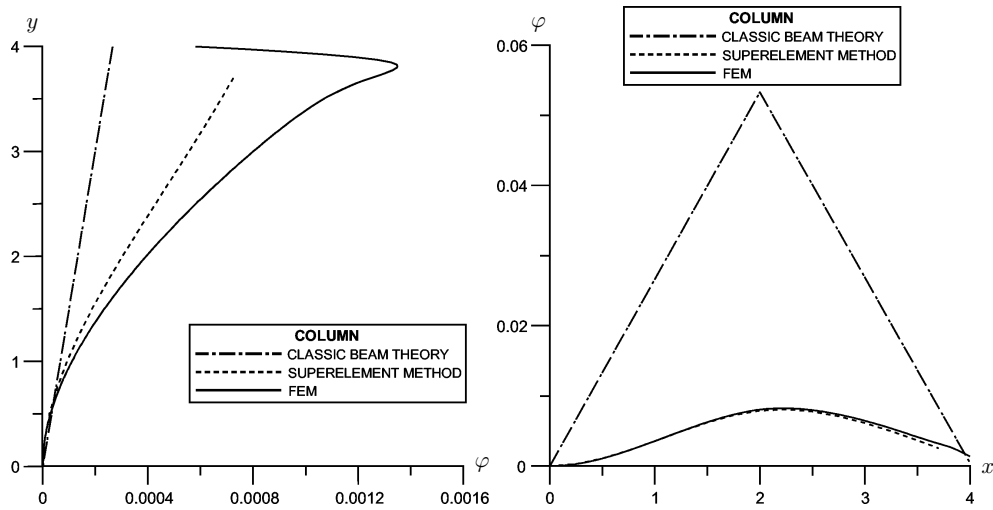

Figure 7. Comparison of rotation angles for both parts of the frame

### Acknowledgements

State Committee for Scientific Research (KBN) has sponsored the research presented in this paper, grant No 7 T07E 01519.

### References

- [1] Vlasov V Z 1961 *Thin-Walled Elastic Beams. Israel Program for Scientific Translations*, Jerusalem, Oldbourne Press, London
- [2] Szmids K 1975 *Engng. Trans.* **23** 447 (in Polish)
- [3] Yang Y-B and McGuire W 1984 *Int. J. Numer Meth. Engng.* **20** 1377
- [4] Yoo C H 1980 *Comp. Struct.* **11** 465
- [5] Kim M-Y, Chang S-P and Kim S-B 1996 *Int. J. Numer Meth. Engng.* **39** 499
- [6] Krenk S and Damkilde L 1991 *J. Engng. Mech. ASCE* **117** 2457