



30th International Conference on Flexible Automation and Intelligent Manufacturing (FAIM2021)  
15-18 June 2021, Athens, Greece.

## Opportunities and challenges for exploiting drones in agile manufacturing systems

Mariusz Deja<sup>1\*</sup>, Mieczysław S. Siemiątkowski<sup>1</sup>, George-Ch. Vosniakos<sup>2</sup>, Gerasimos Maltezos<sup>2</sup>

<sup>1</sup> *Gdańsk University of Technology, Faculty of Mechanical Engineering, Department of Manufacturing and Production Engineering, G. Narutowicza 11/12, PL 80-233 Gdańsk, Poland*

<sup>2</sup> *National Technical University of Athens, School of Mechanical Engineering, Section of Manufacturing Technology, Heroon Politechniou 9, 15780 Athens, Greece*

\* Corresponding author. Tel.: +48 58 347 29 67, e-mail address: [mariusz.deja@pg.edu.pl](mailto:mariusz.deja@pg.edu.pl)

### Abstract

Drones have become an advanced supply chain implementation instrument, especially in connecting warehouses to outlet points or even individual customers. However, their potential application in an intra-logistics framework has not been studied, let alone explored so far. Modeling and simulations in virtual environments can help explore and evaluate the opportunities for practical and profitable applications of drones in manufacturing systems. This paper considers use of drones in replacing or supplementing industrial robots, transportation systems and humans in factories, especially regarding agile manufacturing under the requirements of flexibility, reconfigurability and collaboration. Currently available drone technology regarding positioning, navigation and communication is examined in order to define possible individual tasks and general operations that they can perform, as well as pertinent limitations. A typical scenario of a flexible manufacturing system is simulated and conceptually presented for discussing drone integration and missing links. The main issues refer to mechanical integration with machinery and parts, information integration in the manufacturing system, especially in an Industrial Internet of Things direction, scheduling and collaboration with humans and robots including safety.

© 2020 The Authors. Published by Elsevier Ltd.

This is an open access article under the CC BY-NC-ND license (<https://creativecommons.org/licenses/by-nc-nd/4.0/>)  
Peer-review under responsibility of the scientific committee of the FAIM 2021.

*Keywords:* unmanned aerial vehicles (UAVs); indoor applications; reconfigurable manufacturing systems (RMSs); automatic navigation; material flow

### 1. Introduction

The rapid development of unmanned aerial vehicles (UAVs) and micro aerial vehicles ( $\mu$ AVs) has extended the possible areas of their applications - from monitoring to action, or from “see” to “transform” through “sense” and “move” as categorised in [1]. These vehicles are popularly called drones although they are potentially high capability independent robots [2] with almost no limits regarding degrees of freedom and working space. As a developing technology, it is expected to be growing rapidly over the next decade. However, practical and profitable applications of drones in manufacturing systems are still a big challenge for researchers, let alone for practitioners.

A significant peculiarity is that manufacturing operations are carried out indoors while current focus is on outdoors applications of drones, especially in difficult to reach environment. A second peculiarity is that the autonomous movement of drones in a factory is constrained by ground obstacles but also by other UAVs depending on the number of UAVs used and the potential overlaps of their respective working envelopes. In addition, the duration of continuous flight is limited by UAV load, i.e. the weight of UAV equipment and parts carried, as well as battery capabilities. Gyroscopes, accelerometers and attitude sensors embedded in UAVs enable autonomous computer based flight control. One of the few singly relevant examples concerns a UAV collaborating with humans for detecting missing tools in an

2351-9789 © 2020 The Authors. Published by Elsevier Ltd.

This is an open access article under the CC BY-NC-ND license (<https://creativecommons.org/licenses/by-nc-nd/4.0/>)  
Peer-review under responsibility of the scientific committee of the FAIM 2021.

10.1016/j.promfg.2020.10.074

Airbus factory [3]. However, this is not a logistics but an inspection application.

This paper investigates drone use in small and medium size manufacturing companies allowing them to reach logistic agility without major financial outlays. Section 2 deals with issues related to use of drone technology for parts manufacturing. In Section 3 a drone application framework in a typical reconfigurable manufacturing system is presented, and the routings of parts manufactured are simulated. Section 4 discusses advantages of the use of UAVs for the intra-logistics purposes over equivalent conventional solutions i.e. cooperating conveying or dedicated AGV-based systems. Section 5 summarises conclusions and further research.

## 2. Drone basic technology for manufacturing systems

### 2.1. Legislation

The newest EU legislation pertains only to outdoor unmanned aircraft (UA) system operations [4]. Indoor operations occur in closed spaces where the likelihood of a UA escaping into the outside airspace is very low. However, some of the rules, procedures and terms have been or could be adopted from these regulations to legislation to be established for indoor operations. Operating beyond visual line of sight (BVLOS) may be required, which is prohibited in many countries, thereby reducing the applications of drones even in outdoor environment.

### 2.2. Drone types and functions envisaged

In warehouse environments the main applications envisaged have been inspection and surveillance regarding inventory management, as well as intra-logistics. Significant limitations were defined to be payload, gripping/placing movements and navigation [5]. Similar considerations pertain to a manufacturing environment. In this case the main tasks to be executed by the drones are pickup of a part or tool from a designated storage jig, takeoff, transportation above a placing jig, landing, placing. In an analogous manner, an empty drone will take off from a storage jig or from a designated parking/charging place or indeed from its last delivery jig and move above the next storage jig where the part to be picked up resides, where it will land and pick up the part. Thus, standardised storage pallets and jigs associated to machines tools, storage bays etc. are necessary, as well as standardised parking / charging places, see Fig. 1. Standardisation mainly pertains to the drone's mechanical structure and in particular its skids and part gripping mechanism.

There are currently several alternative types of drones, which can be categorized using different methods and depending on many of their characteristics. Considering the classification made in [6], the drone best fitted in the manufacturing environment would be in the heavier limit of the rotary wing MAV (micro aerial vehicle) category, consisting of four or six rotors. With this type, high maneuverability, vertical takeoff and landing (VTOL), hover in place and high controllability can be achieved, which are necessary for flying in confined spaces.

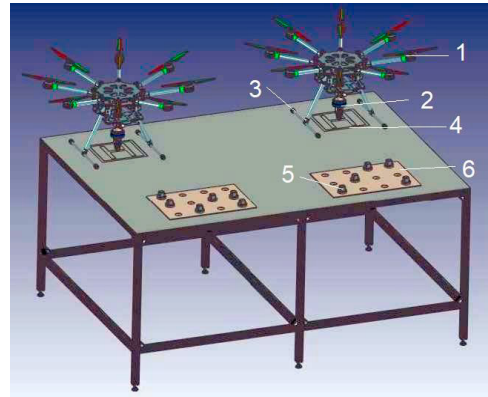

Fig. 1. Simplified configuration of a UAV pickup and delivery area complementing processing / assembly workstations in a manufacturing system [7] : 1: UAV, 2: gripper, 3: skid, 4: part holding jig, 5: part, 6: pallet

The main drawback of such drones, and every drone, is the limited amount of flight time that can be achieved. For small drones, the best power supply is through LiPo batteries with 3-6 cells in series (high efficiency with low weight), but even so, 30min of airtime is the limit. In order to achieve almost continuous operation and to avoid lengthy intervals for battery recharging, an automatic mechanism can be implemented for immediate battery replacement. Such a mechanism would need an accurate localization and docking control system. A mechanical solution proposed used a bigger platform with arms that close placing the drone in the right position [8].

Apart from the power supply, the hardware of a common drone necessarily consists of the frame, the motors, the rotors (CW and CCW rotation for torque balancing), the Electronic Speed Controllers (ESCs) for optimum current supply to the motors, a Battery Elimination Circuit (BEC) for voltage regulation if needed, a flight control unit (FCU) and an inertial measurement unit (IMU), which includes accelerometers, gyroscopes and possibly magnetometers [9]. If autonomous navigation is needed, some more sensors (GPS for open spaces or camera, laser etc. for inner spaces) and on board or central computer can be used [10].

For an intra-logistics drone application to be actually implemented, some initial system identification is necessary and the main components of a drone, which is capable of such a task, must be described. In this paper, a case of transporting materials, tools and parts up to 2kg is considered. Therefore, the thrust being generated by the subsystem of motors-propellers, should be higher than the weight of the drone (including the part gripping mechanism) plus the payload, usually by a factor of 1.5 (2kg payload plus about 2.5kg of weight needs 67.5N thrust, that is divided among 4 or more rotors), so the drone can easily follow a specific trajectory. The most suitable motors in this occasion, are electric DC brushless motors, due to their small size and weight, high power concentration and high spin. Both the frame and the propellers could be made of carbon fiber, with high specific strength [11]. Appropriate size and pitch of the propellers and maximum spin should be selected, so that enough thrust can be generated avoiding interaction of airflows produced by neighboring rotors [12]. Finally, the ESC needs to be able to

drive the motor to its maximum speed, so it needs to withstand the maximum current of the motor.

Taking into account the specific type of motors being used, Power in kW can be calculated, as follows:

$$P = (\tau + k_t I_0)(k_t I_0 R_m + \tau R_m + k_t k_v \omega) / k_t^2 \tag{1}$$

where  $I_0$  is the current without load,  $\tau$  is motor torque,  $I$  is the input current,  $R_m$  is motor resistance,  $\omega$  is motor spin,  $k_t$  is the torque proportionality constant and  $k_v$  is a proportionality constant indicating a back-EMF generated per revolution. Through Momentum Theory, air velocity when hovering can be obtained as:

$$u_h = \sqrt{T/2\rho A} \tag{2}$$

where  $T$  is thrust,  $\rho$  is air density and  $A$  is disk area of the propeller. With these two equations, a connection between thrust and motor-propeller parameters can be presented:

$$T = (k_v k_\tau \sqrt{2\rho A \omega} / k_t)^2 \tag{3}$$

where  $k_\tau$  is a constant connecting torque to thrust. Through this equation, it is possible, not only to find the appropriate components for a specific design (using parametric analysis due to the multitude of factors), but also to simulate the operation of the drone, along with the other kinematic and dynamic equations, assisting the development of control and localization algorithms [13]. Depending on the simplifications of phenomena and assumptions used different equations can

be employed, which account for factors such as airflow from the other propellers, differences in air density etc. Choosing a design based on such equations is obviously difficult.

In Fig. 2 a UAV configuration from *eCalc* is displayed, a web-based program with an extensive database of remote controlled devices and the capability of carrying out calculations based on the specific components, the values given by the user and equations such as (1)-(3) above. With this software, many multirotor designs can be configured, in order to find one that complies with the requirements. The main issue with this design, was to achieve enough thrust and Time of Flight, with small rotors, so the drone can carry out manoeuvres inside the manufacturing area. This was achieved by paying attention to the battery and using high spin rotors. In particular, the design consists of Cobra C-3520/12(820) motors, T-Motor 10X4 propellers, LiPo 10000 mAh-35/50 C battery, max 50 A ESC. It achieves 7.5 min hover time at max payload. Estimated price is 700 \$ (without sensors). As shown, Hexa- or Octacopters are also a viable solution, because, although they require more space, they have higher lift capabilities and even if a rotor fails, through controlling the other 5 rotors, safe landing is ensured.

### 2.3. Indoor localization

Outdoor UAVs can offer accuracy in the range of about 20 mm during surveillance and/or measurements of large areas [14]. Indoor drones cannot use conventional global positioning systems (GPS) since this is generally not available inside buildings. Advantages, limitations and cost of navigation



Fig. 2. Configuration of a drone for manufacturing

configurations and pertinent sensor technologies for lightweight UAV autonomous indoor flight have been reviewed in [15]. Preference is given to simultaneous localization and mapping (SLAM) algorithms.

Continuous localisation of drones indoors can be based on visual SLAM employing a mono or stereo on-board camera to create a 3D virtual map in real time while the drone is navigated locating itself inside the map, which can be shared among different devices. Commercially available implementations claim an accuracy of up to 50 mm [16].

SLAM algorithms have the capability of reconstructing the indoors environment, which is vital if the latter is changing. However, this can be superfluous in a factory, where all objects in a zone 2-5 meters above the ground may be considered a structured and fixed environment, adequately described in a CAD model of the factory. The drones are expected to circulate within that zone, except for the servicing points which can generally also be fixed and in any case they are associated with specific vertical drone movements that can be treated separately in terms of localisation.

A control algorithm for Parrot AR Drone designed in Matlab\Simulink<sup>TM</sup> was used and enhanced by integrating a Vicon Capture System, whose position estimation was closer to the real position than the drone sensors' estimation [17].

In structured indoor environments with invariant texture and typical indoor illumination low-cost localization to guide UAV flights is possible with data provided by a RGB-D sensor, an inertial measurement unit (IMU), an ultrasonic sensor and optical flow-based velocity estimates [18].

A classic solution is based on triangulation. A transmitter is placed on the drone and at least three receivers are placed at known positions in space. Based on the particular nature of the signal the measuring principle may be based on time of flight, signal strength or phase finally yielding distances from the known receiver positions. According to the triangulation formulation, two low power lasers scan two different planes containing the object at hand, thereby identifying two lines on whose intersection the object lies [19]. Laser range finders belong to this class, but a complete review of similar solutions can be found in [20].

Another solution for precision location and routing within buildings is Ultra Wide Band (UWB) technology, which employs data transmission techniques spreading the radio energy over a very wide frequency band, with a very low power spectral density. The latter limits the interference potential with conventional radio systems, whereas high bandwidth can allow high precision for location and imaging devices [21]. A methodology for mapping and localization of UAVs based on the integration of distance estimations to UWB sensors and 3D point-clouds from RGB-D sensors has been reported in [22]. A 3D map is constructed and is further integrated into a Monte Carlo Localization method to robustly estimate the UAV pose.

#### 2.4. Indoor navigation

A characteristic software architecture for safe and reliable autonomous navigation of UAVs in GPS-denied areas employs a 6D localization approach based on visual odometry

and Monte Carlo localization, or a variant of the Lazy Theta algorithm for motion planning exemplified through autonomous local obstacle avoidance, and local path planning tasks [23].

However, in our case the envisaged basic drone navigation should be certainly automatic but not fully autonomous. The trajectory to be followed for each transportation or movement task is defined beforehand, because the manufacturing system environment is structured and few deviations are to be expected, if any at all.

At a second level, some autonomy can be allowed locally, especially in two cases, i.e. at docking (where interference with workers may also exist) or in cases where trajectories of different drones may cross each other. This can be based on visual information through the on-board camera and associated local manoeuvring at the accuracy level required. The trajectory crossing case could be altogether avoided if dealt with through scheduling which should not allow crossing of different drones' trajectories, or by not allowing overlap of the regions of activity of different drones. Otherwise, it would require real-time motion planning as in autonomous navigation examples [24].

In the basic formulation of automatic navigation envisaged, the target is for the drone to follow as precisely as possible the pre-defined trajectory. As a first step a mathematical model of the drone can be created based on the equation of motion and forces / moments using the Newton-Euler method. Tilting rotors have been successfully modelled in the corresponding control scheme and simulated under ideal and non-ideal (noisy) conditions [25]. A cascaded PID controller was designed to track the given trajectory in [26]. Simulation can be employed to test the controller, which can also include the performance of the sensors used for feedback, even encompassing the pertinent noise [27]. Experimental tuning of the controllers can lead to precise movements and close following of desired trajectory [28].

Robust trajectory control using acceleration feedback signals is reported in [29]. Reference attitude angles are determined through a nonlinear optimisation algorithm. Furthermore, an acceleration-based disturbance observer is designed to estimate disturbances acting on the positional dynamics of a quadrotor. For attitude control, nested position, velocity, and inner acceleration feedback loops consisting of PID and PI type controllers are developed to provide high robustness against external disturbances. Reliable angular acceleration is estimated through a cascaded filter structure.

A high-level cascade control system guides the UAV in path-following tasks involving a kinematic controller responsible for generating reference velocities and a PD one, responsible for tracking such reference velocities [18].

#### 2.5. Communication

Control is typically executed on an onboard microcomputer but scheduling and trajectory related data are normally generated on a central node and transmitted to the drone. Communication from the central computer to the microcontroller is in any case necessary, the amount of data and frequency of transmission varying depending on the



control model adopted. In manually guided outdoors drones, navigation signals are provided through 2.4 GHz radio waves. Many drone controllers use Wi-Fi, which can be transmitted on the 2.4 GHz spectrum, thus smartphones can directly intercept communications. For indoors applications radio communication at 1 kHz and Zigbee at 100 Hz have been reported [30].

### 3. Drone application framework

#### 3.1. Typical Example

A manufacturing system including a machining shop and an assembly shop is suggested as testbed, see Fig. 3. This comprises a dispatching centre (DC), an automatic storage and retrieval station (AS/RS), a turning machine (T), a milling machine (M), 3 palletised milling stations (MS1÷MS3), two multi-tasking machines (MT1÷MT2), parts loading / unloading stations (Ld/UnLd), assembly stations (Asby 1 and Asby 2), a shipment depot SD. In the storage and assembly area specific locations are designated (L1÷L5). Three UAVs are available (UAV1÷UAV3) as well as a battery recharging station for them (RS). Three stages can be designated: stage 1: preliminary (datum machining), stage 2: milling and drilling operations, stage 3: turning, milling and drilling.

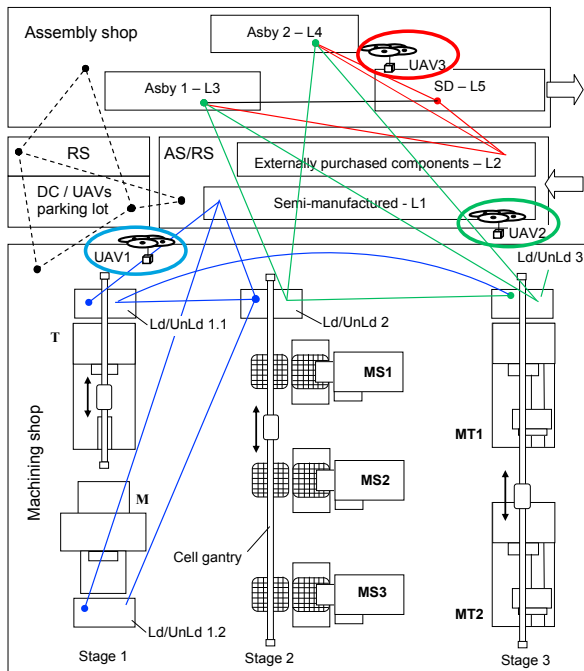

Fig. 3. Schematic layout configuration of a manufacturing system with UAVs applied to internal logistics tasks

The machining system can be classified as a Reconfigurable Manufacturing System (RMS) in which capacity can be added in the form of additional machine resources in cells as is widely applied by US automotive manufacturers [31]. As a generalisation, the three-stage symmetric RMS configuration shown in Fig. 4 possibly

employs drones to internal logistics tasks (and potentially machine / process inspection).

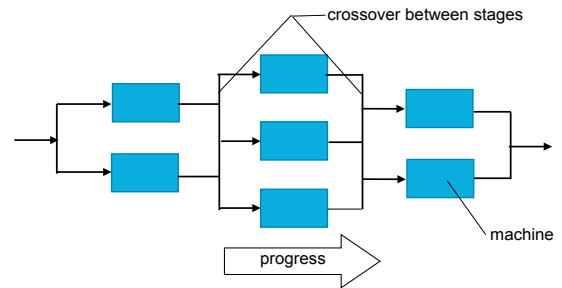

Fig. 4. Three-stage symmetric RMS configuration

The crossover (material transfer between stages) is accomplished by UAVs, whereas material transfer within cells (stages 2 and 3) is accomplished by cell gantries. Drones are scalability friendly, since, in addition to other advantages, they do not occupy space on the ground.

Two types of products with associated material flows are manufactured in the outlined system, their bills of materials containing 4 parts [C1, C2, C5, B] and [C3, C4, C6, B] respectively, C denoting fabricated and B bought out parts. Their routings are shown in Fig. 5.

PART	ASRS-L1	Ld 1.1	Ld 1.2	T	M	UnLd1.1	UnLd1.2	Ld 2	MS Cell	UnLd 2	Ld 3	MT Cell	UnLd 3	Asby-L3	Asby-L4	SD-L5	
C1	UAV1	UAV1	UAV1	UAV1	UAV1	UAV1	UAV1	UAV1	UAV1	UAV1	UAV1	UAV1	UAV1	UAV1	UAV1	UAV1	UAV1
C2	UAV1	UAV1	UAV1	UAV1	UAV1	UAV1	UAV1	UAV1	UAV1	UAV1	UAV1	UAV1	UAV1	UAV1	UAV1	UAV1	UAV1
C3	UAV1	UAV1	UAV1	UAV1	UAV1	UAV1	UAV1	UAV1	UAV1	UAV1	UAV1	UAV1	UAV1	UAV1	UAV1	UAV1	UAV1
C4	UAV1	UAV1	UAV1	UAV1	UAV1	UAV1	UAV1	UAV1	UAV1	UAV1	UAV1	UAV1	UAV1	UAV1	UAV1	UAV1	UAV1
C5	UAV1	UAV1	UAV1	UAV1	UAV1	UAV1	UAV1	UAV1	UAV1	UAV1	UAV1	UAV1	UAV1	UAV1	UAV1	UAV1	UAV1
C6	UAV1	UAV1	UAV1	UAV1	UAV1	UAV1	UAV1	UAV1	UAV1	UAV1	UAV1	UAV1	UAV1	UAV1	UAV1	UAV1	UAV1

Fig. 5. Routings of parts manufactured in the system

Three UAVs are used in this case corresponding to three clusters of destinations which are formed according to various criteria, vicinity of nodes within the same cluster and independence (non-overlap) of different clusters being two of the most obvious ones, see e.g. [3].

The itineraries of UAV1, UAV2 and UAV3 serving clusters 1, 2, and 3 respectively are shown in Fig. 3 in blue, black and red, respectively.

#### 3.2. Mechanical interfaces to machines and parts

Standardised temporary storage bays are assigned to each machine tool (as well as to other workstations as required) and on each of them pallet positions are designated, as well as single part holding jigs for direct manipulation from the UAVs. Cutting tools can be dealt with in the same way. A robot is foreseen as an interface between the part transferring system (in this case the UAVs) and the machine, see Fig. 6.

A gripper is foreseen as the mechanical interface between the UAV and the part or tool being transported. The gripper should be activated (opened) electrically but it should be kept in the closed position, i.e. its normal state, passively, e.g. by a spring-loaded mechanism. Several super lightweight finger-

based gripper designs have been proposed capable of lifting typically parts weighing 2 kg, e.g. [32], whereas standard universal robotic grippers are also available commercially [33].

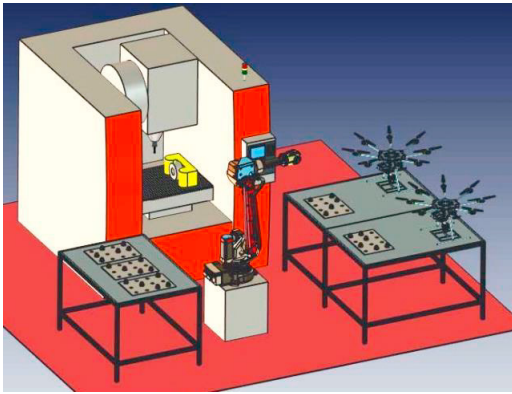

Fig. 6. Layout of a machine tool with UAV robot mechanical interfaces [7].

Typical parts are small and relatively light, see e.g. Fig. 7.

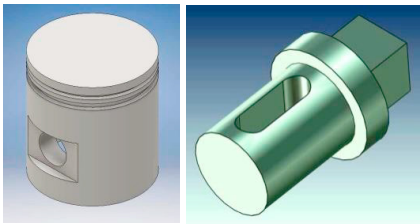

Fig. 7. Typical small parts suitable for handling by drone [7]

### 3.3. Information integration

The automated flights of UAVs in a manufacturing system require data and information transfer between entities within a manufacturing system. The main type of data to be exchanged with UAVs relates to scheduling of the latter. It pertains to the orders received, to the product routings, to the predefined trajectories, including alternative ones, too, between origins and destination workstations, as well as to the actual position and state of each UAV for monitoring purposes, including faults and possible resets.

Cyber Manufacturing Systems [34] may be constructed using Digital Twins (virtual model of the system), that mainly help in monitoring, making fault diagnosis and implementing resets. However, the digital model of the environment is mainly furnished as a static CAD model, whereas only deviations / corrections based on the on-board camera of the UAVs are envisaged to be superimposed in real time for the sake of enhanced accuracy. In addition the pose of each UAV should be embedded in the digital model according to either simulated navigation or sensor-based feed-back data.

### 3.4. Scheduling

A scheduler of a drone-served Manufacturing System is essentially the same as those of AGV-served systems. The

main difference is expected to relate to: (a) the restricted time of transport from one origin to the next destination (b) the necessary charging time between flights that is significant in relation to the latter (c) the possibility of defining non-overlapping zones or even different flying heights in order to achieve parallel missions of different UAVs with minimal collision danger.

Schedulers may be based on heuristics, on variations of the Travelling Salesman Problem, or more recently on applied AI techniques. For example, a particle swarm optimization algorithm with an embedded heuristic to suit near real-time operation and quick response towards uncertain events has been demonstrated [35]. In addition, scheduling as well as route creation and assignment in connection to load carrying capacity can be studied by Genetic Algorithms [36]. Interesting variations of scheduling is the re-scheduling operation that is necessary in the event of unpredictable break-downs of machines or of UAVs, too, which should start by keeping the tasks already running and optimally re-assigning the rest.

A sample result for the system of Fig. 3 is shown in Fig. 8 corresponding to FIFO strategy; battery charging operations of UAVs 1 & 2, in particular are shown by red coloured boxes. Furthermore, inspection tasks may be carried out by drones, esp. vacant for preventive maintenance of machines.

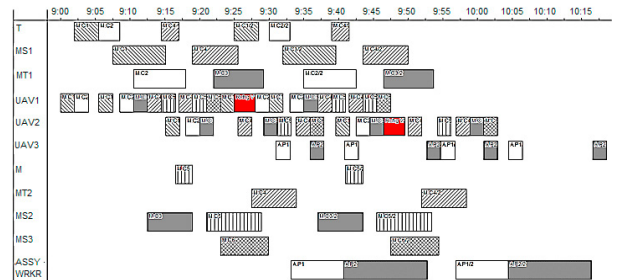

Fig. 8. Gantt chart of operational schedule accomplished

### 3.5. Collaboration in handling tasks

Collaboration of drones and humans in physical handling tasks is not envisaged in the first place. It may become necessary in cases of break-down diagnosis and resetting. Yet, the main aim is to let drones complete their tasks without human intervention.

Drone-robot collaboration is envisaged as indirect, i.e. through jigs where the robot places parts and tools and from which the drone picks them up and vice versa. Jigs ensure that the parts are properly oriented and positioned; they also ensure that the drones are accurately docked with respect to parts. In this way gripping and un-gripping for parts and tools should not require special compliance-based methods, i.e. impedance control.

Collaboration of drones with other drones in the current scenarios considered is not envisaged either. However, in case of high payloads, a swarm of UAVs might be needed thus making collaboration as well as novel ways of control a necessity. In such scenarios, Bluetooth based communication (low-cost, energy efficient, lightweight) can be used to send

location and trajectory data between the drones, so, in fusion with range measurement from signal strength, their relative location inside the swarm can be determined, for collision avoidance (using AI techniques) [37].

### 3.6. Safety

Several risks and management scenarios may be identified for outdoor UAVs [38]. Most of them are also applicable to indoor UAVs serving manufacturing systems. The first group of such risks refers to verifying the good operational state of the UAV, i.e. specific checks of structure, batteries, electric motors, electronic components within the framework of predictive / preventive maintenance. A big data approach may prove especially useful in this context. The second group of such risks involves availability of redundant critical parts and services (IMU, localisation) as well as standard control of failure modes. The third group of risks aims at warning humans of the presence of UAVs through audio or visual cues and minimising flying time over humans or equipment, as a trajectory pertaining issue. In every occasion and especially for autonomous flights, failsafe protocols should be established (built-in parachute, appropriate safety algorithms, never completely discharged batteries for extra propulsion in emergency landings).

## 4. Discussion

Practical and profitable applications of drones in manufacturing systems are still a big challenge for researchers, and especially so for practitioners. Drones, in addition to other advantages they offer, do not occupy space on the ground but on the other hand their operating space and autonomous movement may be constrained in some cases by ground obstacles and other UAVs. As shown in this paper, they can be easily employed to internal logistic tasks between different stages of RMS, however material transfer within cells or between UAVs and machine tools may be accomplished by other intra-logistics systems e.g. cell gantries, conveyors or robots. Full integration of drones into existing manufacturing systems is an important technological challenge which, according to proposed alternatives in Sections 3 above, may also be achieved easier than for conventional systems. Furthermore, return on investment can be high due to relatively low purchase costs of UAVs, jigs and control software as well as to higher speed of intra-logistics operations. On the other hand, potential drone failures in the manufacturing plants increase the fear of using them, hence required failsafe protocols have to be established.

Socio-cultural and behavioural issues, such as protection of personal data as well as the common acceptance of replacing or assisting people, should be also considered at the planning stage of their practical use.

The suggested use of UAVs (quadcopter drones) for intra-logistics purposes within multi-stage multi-station manufacturing facilities incorporating both processing and assembly sections has substantial advantages over equivalent conventional solutions such as conveyor or AGV systems. These potential benefits pertain in particular to improved

throughput and higher system productivity, reduced work-in-process inventories and increased capacity scalability of a production system. The latter is an inherent characteristic of agile manufacturing systems, associated with the possibility for rapidly and cost-effectively adjusting production capacity in discrete time intervals, entailing layout reconfiguration in response to dynamically changing market demands impacting on production volume and product variety.

AGVs and various types of conveyor systems associated work on a plane (floor or overhead) and in very rigidly defined pathways. Thus they exhibit limitations with the occurrence of queuing congestions as well as interference with manually operated trucks, workers or other material handling resources. The basic rationale for the increase in the operational efficiency of multi-stage manufacturing facilities operated by drones lies in that the latter are capable of transporting materials exploiting 3D space rather than along a line or a plane. This results in direct unobstructed transfers of workpieces and tooling from specified origin to destination locations, scattered throughout the entire integrated production facility, as implied in the provided instance case study, easily omitting ground obstacles when moving in the longitudinal, transverse or oblique directions as required, at definite altitudes of a respective working area indoors.

## 5. Conclusions

UAVs can be used to replace AGVs, conveyors and other types of flexible logistics equipment in manufacturing systems, the main constraint being the size and weight of parts transported. Small parts weighing less than 2 kg are targeted in this work.

Their scheduling under short flight and significant battery charging time constraints is important and could be achieved by exploiting applied AI techniques.

Automatic navigation can be based on pre-defined trajectories between workstations; alternative trajectories should provide for the extra necessary flexibility in scheduling.

Navigation accuracy typically better than 10 mm is most important to achieve and can be studied by controller design and simulation based on typical sensors currently found on even low-cost UAVs as well as a smart low-cost localization technique. Laser-based or other types of triangulation sensors seem a promising solution for small to medium size manufacturing systems.

Several mechanical interfacing issues should also be solved before UAVs are reliably applied in reconfigurable manufacturing, notably an ultra light on-board gripping device and universal or custom work-holding / docking jigs.

Finally, digital twins should be setup to enable easier monitoring of drones in manufacturing systems as well as resetting to operational state when faults are detected.

## References

- [1] Maghazei O, Netland T. Drones in manufacturing: exploring opportunities for research and practice. *J Manuf Technol Manag* 2019.
- [2] Floreano D, Wood RJ. Science, technology and the future of small autonomous drones. *Nature* 2015;521:460–6.

- [3] Martinez-de Dios JR, Torres-Gonzalez A, Paneque JL, Fuego-Garcia D, Ramirez JRA, Ollero A. Aerial Robot Coworkers for Autonomous Localization of Missing Tools in Manufacturing Plants. 2018 Int. Conf. Unmanned Aircr. Syst., IEEE; 2018, p. 1063–9.
- [4] (EU) 2019/ 947, Commission Implementing Regulation (EU) 2019/947 of 24 May 2019 on the rules and procedures for the operation of unmanned aircraft 2019.
- [5] Wawrla L, Maghazei O, Netland T. Applications of drones in warehouse operations. Whitepaper. 2019.
- [6] Hassanalian M, Abdelkefi A. Classifications, applications, and design challenges of drones: A review. *Prog Aerosp Sci* 2017;91:99–131.
- [7] Pochyluk M. Analysis of applications of unmanned aerial vehicles in technological processes (in Polish). MSc Thesis, Gdansk University of Technology, 2019.
- [8] Fujii K, Higuchi K, Rekimoto J. Endless Flyer: A Continuous Flying Drone with Automatic Battery Replacement. 2013 IEEE 10th Int. Conf. Ubiquitous Intell. Comput. 2013 IEEE 10th Int. Conf. Auton. Trust. Comput., IEEE; 2013, p. 216–23.
- [9] Parihar P, Bhawsar P, Hargod P. Design & Development Analysis of Quadcopter. *Int J Adv Comput Technol* 2016;5:2128–33.
- [10] Scaramuzza BD, Achtelik MC, Doitsidis L, Fraundorfer F, Kosmatopoulos E, Martinelli A, et al. Vision-Controlled Micro Flying Robots. *Robot Autom Mag IEEE* 2014;21:26–40.
- [11] Wei P, Yang Z, Wang Q. The Design of Quadcopter Frame Based On Finite Element Analysis, 2015, p. 1353–6.
- [12] Kuantama E, Craciun D, Tarca R. Quadcopter body frame model and analysis. *Ann Univ Oradea Fascicle Manag Technol Eng* 2016;120:71–4.
- [13] Zlatanov N. Multicopter Aircraft Dynamics, Simulation and Control. Technical Report, p. 22, [www.researchgate.net/](http://www.researchgate.net/), accessed 21/3/2020.
- [14] Jacobs G, Schlüter F, Schröter J, Feldermann A, Strassburger F. Cyber-Physical Systems for Agricultural and Construction Machinery—Current Applications and Future Potential, Springer, Cham; 2017, p. 617–45.
- [15] Li Y, Seanavino M, Capello E, Dabbene F, Guglieri G, Vilardi A. A novel distributed architecture for UAV indoor navigation. *Transp Res Procedia* 2018;35:13–22.
- [16] Accuware. Dragonfly: Precise 3D location for robots and drones using standard cameras, <https://www.dragonflycv.com/>, accessed: 21/3/2020.
- [17] Al Habsi S, Shehada M, Abdoon M, Mashood A, Noura H. Integration of a Vicon camera system for indoor flight of a Parrot AR Drone. 2015 10th Int. Symp. Mechatronics its Appl., IEEE; 2015, p. 1–6.
- [18] Santos MCP, Santana L V., Brandão AS, Sarcinelli-Filho M, Carelli R. Indoor low-cost localization system for controlling aerial robots. *Control Eng Pract* 2017;61:93–111.
- [19] Liu H, Darabi H, Banerjee P, Liu J. Survey of Wireless Indoor Positioning Techniques and Systems. *IEEE Trans Syst Man Cybern Part C (Applications Rev)* 2007;37:1067–80.
- [20] Kuutti S, Fallah S, Katsaros K, Dianati M, Mccullough F, Mouzakitis A. A Survey of the State-of-the-Art Localization Techniques and Their Potentials for Autonomous Vehicle Applications. *IEEE Internet Things J* 2018;5:829–46.
- [21] Cernohorsky J, Jandura P, Rydlo P. Real time ultra-wideband localisation. 2018 19th Int. Carpathian Control Conf., IEEE; 2018, p. 445–50.
- [22] Perez-Grau FJ, Caballero F, Merino L, Viguria A. Multi-modal mapping and localization of unmanned aerial robots based on ultra-wideband and RGB-D sensing. 2017 IEEE/RSJ Int. Conf. Intell. Robot. Syst., IEEE; 2017, p. 3495–502.
- [23] Perez-Grau FJ, Ragel R, Caballero F, Viguria A, Ollero A. An architecture for robust UAV navigation in GPS-denied areas. *J F Robot* 2018;35:121–45.
- [24] Grzonka S, Grisetti G, Burgard W. A fully autonomous indoor quadrotor. *IEEE Trans Robot* 2012;28:90–100.
- [25] Alkamachi A, Ercelebi E. Modelling and control of H-shaped racing quadcopter with tilting propellers. *Facta Univ Ser Mech Eng* 2017;15:201–15.
- [26] Abdelhay S, Zakriti A. Modeling of a Quadcopter Trajectory Tracking System Using PID Controller. *Procedia Manuf* 2019;32:564–71.
- [27] Sun Y. Modeling, identification and control of a quad-rotor drone using low resolution sensing. MSc Thesis, University of Illinois at Urbana-Champaign, 2012, [www.ideals.illinois.edu](http://www.ideals.illinois.edu), accessed: 21/3/2020.
- [28] Mellinger D, Michael N, Kumar V. Trajectory generation and control for precise aggressive maneuvers with quadrotors. *Int J Rob Res* 2012;31:664–74.
- [29] Zaki H, Alcan G, Unel M. Robust trajectory control of an unmanned aerial vehicle using acceleration feedback. *Int J Mechatronics Manuf Syst* 2019;12:298.
- [30] Khosiawan Y, Nielsen I. A system of UAV application in indoor environment. *Prod Manuf Res* 2016;4:2–22.
- [31] Koren Y, Gu X, Guo W. Reconfigurable manufacturing systems: Principles, design, and future trends. *Front Mech Eng* 2018;13:121–36.
- [32] Barrett E, Reiling M, Fumagalli M, Carloni R. The SHERPA gripper: Grasping of small-scale UAVs. 2016 IEEE Int. Symp. Safety, Secur. Rescue Robot., IEEE; 2016, p. 384–9.
- [33] Fumagalli M, Stramigioli S, Carloni R. Mechatronic design of a robotic manipulator for Unmanned Aerial Vehicles. 2016 IEEE/RSJ Int. Conf. Intell. Robot. Syst., IEEE; 2016, p. 4843–8.
- [34] Jeschke S, Brecher C, Meisen T, Özdemir D, Eschert T. Industrial Internet of Things and Cyber Manufacturing Systems, Springer, Cham; 2017, p. 3–19.
- [35] Khosiawan Y, Park Y, Moon I, Nilakantan JM, Nielsen I. Task scheduling system for UAV operations in indoor environment. *Neural Comput Appl* 2019;31:5431–59.
- [36] Olivares V, Cordova F, Sepúlveda JM, Derpich I. Modeling internal logistics by using drones on the stage of assembly of products. *Procedia Comput Sci* 2015;55:1240–9.
- [37] Coppola M, McGuire KN, Schepher KYW, de Croon GCHE. On-board communication-based relative localization for collision avoidance in Micro Air Vehicle teams. *Auton Robots* 2018;42:1787–805.
- [38] Clothier R, Walker R. Safety Risk Management of Unmanned Aircraft Systems. In: Valavanis KP, Vachtsevanos GJ, editors. *Handb. Unmanned Aer. Veh.*, 2015, p. 2229–75.