

# Pitting corrosion in steel and electrochemical noise intensity

Janusz Smulko <sup>a,b</sup>, Kazimierz Darowicki <sup>b</sup>, Artur Zieliński <sup>b</sup>

<sup>a</sup> *Department of Measurement Equipment, Faculty of Electronics, Telecommunication and Informatics, Technical University of Gdańsk, Narutowicza 11/12, 80-952 Gdańsk, Poland*

<sup>b</sup> *Faculty of Chemistry, Department of Anticorrosion Technology, Technical University of Gdańsk, Narutowicza 11/12, Gdańsk, PL-80-952, Poland*

---

## Abstract

Electrochemical noise data in the presence of pitting corrosion were analyzed. A correlation between the intensity of the observed noise and mass loss of steel electrodes was recognized. The registered noise was decomposed into a set of band limited components using wavelet transform. It has been observed that the standard deviation of the chosen component was more strictly correlated with mass loss of electrodes than the standard deviation of the other components. The frequency band of the chosen component was adequate to the band where energy of transients, typical for pitting corrosion dominated. The measurement results were obtained only for the limited number of electrodes due to a very long time of noise observation. © 2002 Published by Elsevier Science B.V.

*Keywords:* Electrochemical noise; Wavelet transform; Pitting corrosion

---

## 1. Introduction

Corrosion processes can be investigated by observation of electrochemical noise. The mentioned fluctuations are usually measured in a three-electrode setup (Fig. 1) [1]. The current  $i(t)$  and voltage  $u(t)$  noise can be observed.

The character and intensity of the observed noise can be explored for a measure of corrosion intensity and identification of corrosion type. In the case of pitting corrosion, a localized kind of corrosion attack, very popular method of noise data analysis is investigation of its pitting index [2] and power spectral density [3–5].

The value of pitting index is based on the measured mean current whereas the observed current noise is mainly caused by one of the two partial currents (anodic or cathodic). This fact significantly limits utilization of pitting index for localized corrosion recognition and evaluation.

When characteristic for pitting corrosion transients are present in data record, the power spectral density of the noise has different slopes in some frequency regions.

The mentioned fact assures a detection of the pitting corrosion existence but does not give any information about its intensity.

Another method is based on wavelet transform, which decomposes recorded noise into parameters related to the band-pass filtered noise components. The energy or standard deviation of the following components can be easily calculated [6]. Distribution of the estimated standard deviation of noise components can be characteristic for different corrosion processes. It is important to recognize, which components are the most valuable for evaluation of pitting corrosion intensity and which are mainly caused by the other noise sources like measurement instrumentation or outside distortion. In this paper the authors try to find an answer to the mentioned problem.

## 2. Signal decomposition by wavelet transform

Time record of discrete signal  $x(t_n)$  ( $n = 1, 2, \dots, N$ ) can be decomposed by wavelet transform into a set of band limited components called approximations and details that are low-frequency and high-frequency components of  $x(t_n)$ . Mallat [7] proposed an algorithm of the discrete wavelet transform that performs such

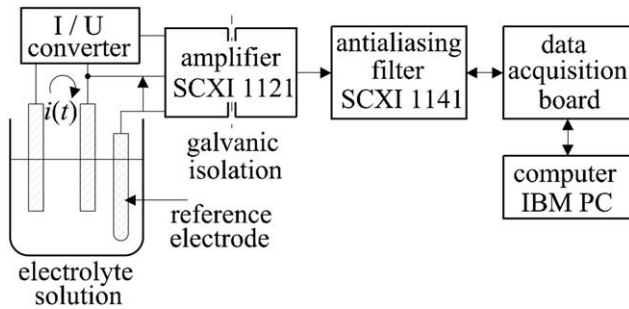

Fig. 1. Measurement setup.

decomposition. A broadband signal is decomposed into a collection of successively more bandlimited details by repeatedly dividing the frequency range by two at each level of decomposition, that assures logarithmically decreasing frequency intervals. The structure of the filter banks applied in Mallat algorithm is presented in Fig. 2. At each level of decomposition, the analyzed signal is filtered by highpass (HP) and lowpass (LP) digital filter pair, called quadrature mirror filters [7]. After filtering, the outputs are down-sampled ( $\downarrow 2$ ), that means deleting one of every two consecutive samples of the filtered components. Each subband of the two outputs is half the bandwidth of the input to that level.

The lowpass and highpass filters are finite impulse response filters and their coefficients  $l(k)$ ,  $h(k)$  are obtained by applying relationships [8]:

$$\Psi(t) = 2 \sum_k h(k) \Phi(2t - k), \quad (1)$$

$$h(k) = (-1)^k l(N - k), \quad (2)$$

where  $\Psi(t)$ ,  $\Phi(t)$  are adequately the assumed mother wavelet function and its dual function,  $N$  is the length of the filter. The functions  $\Psi(t)$ ,  $\Phi(t)$  are basis functions of wavelet transform [6,8,9]. At the level  $i$ th, the filtered outputs  $x_{A,i+1}$ ,  $x_{D,i+1}$  of the input signal  $x_{A,i}$  are [8]:

$$x_{A,i+1}(n) = \sqrt{2} \sum_k l(2n - k) x_{A,i}(k), \quad (3)$$

$$x_{D,i+1}(n) = \sqrt{2} \sum_k h(2n - k) x_{A,i}(k), \quad (4)$$

where  $k = 1, 2, \dots, N/2^{i+1}$  and  $i = 1, 2, \dots, I$ .

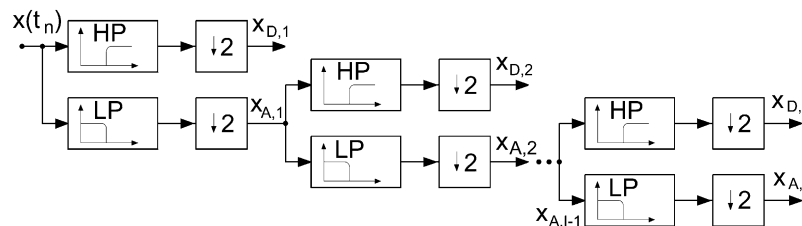

Fig. 2. Algorithm of discrete signal  $x(t_n)$  decomposition by discrete wavelet transform.

The necessary calculations for decomposition of the analyzed signal were performed using function *wavedec* that was included in *Matlab Wavelet* toolbox [9]. The orthogonal function  $\Psi(t)$ , called Daubechies of the fifth order was applied. The main property of the chosen orthogonal  $\Psi(t)$  is that energy of the analyzed signal  $x(t_n)$  is equal to the sum of energies of all components obtained by wavelet transform.

### 3. Experimental

The corrosion processes in 0H18N9 steel were monitored by electrochemical noise measurements. The electrodes were immersed in 0.5 or 1 M solution of  $\text{FeCl}_3$  at room temperature. The surfaces of the working electrodes were mechanically polished with sandpaper to grade 1000 and degreased with acetone just before the measurements.

Described conditions assured the onset of pitting corrosion within minutes after electrode immersion in the electrolyte. The current and voltage fluctuations at a sampling frequency  $f_s = 9$  Hz were recorded starting 30 min after the electrodes were dipped in the electrolyte solution. The time of data collection was the same for all the data records and amounted 18 h.

The loss of mass of working electrodes was measured just after finishing the noise measurements and drying of the electrodes. The surfaces of the working electrodes had visible pits. A dozen of identically prepared electrode sets was used.

### 4. Results and discussion

The characteristic transients for pitting corrosion were observed in current fluctuations (Fig. 3). The shapes of the recorded transients can be characterized by a rapid increase in the instantaneous value and exponential decay to the previous state. If exponential decay ( $\sim e^{-t/\tau}$ ) is assumed for the transients, the characteristic roll-off around frequency  $f_c = 1/(2\pi\tau)$  in the shape of electrochemical noise power spectral density should be observed. Fig. 4 presents current noise power spectral density of a few noise records with a visible roll-



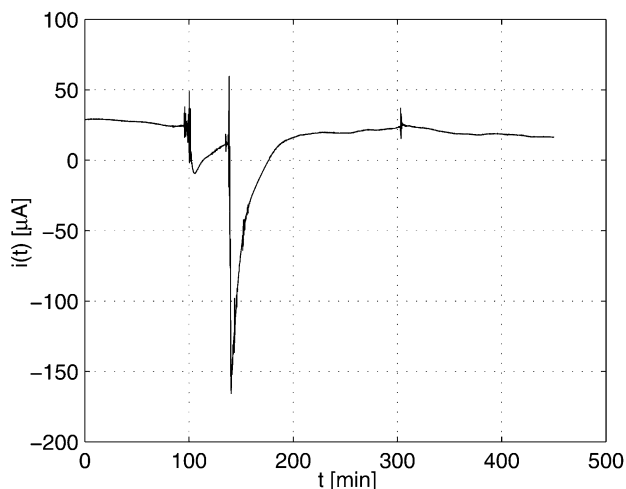

Fig. 3. Time record of current noise  $i(t)$  with characteristic for pitting corrosion transients.

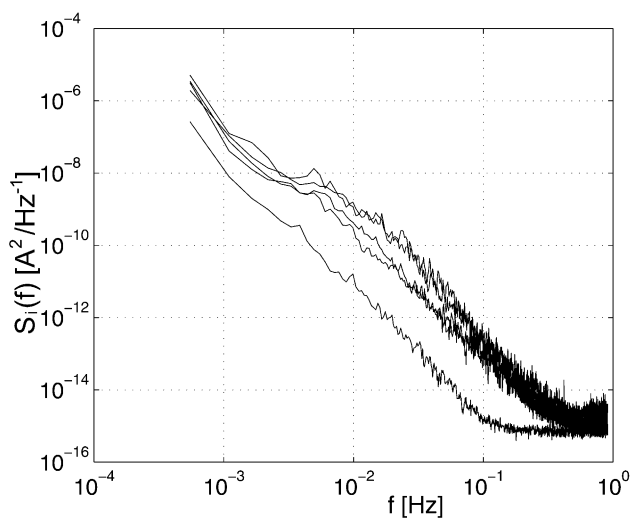

Fig. 4. Power spectral densities  $S_i(f)$  of current noise versus frequency  $f$ .

off around frequency  $f \approx 10^{-2}$  Hz that can be explained by the observed transients in data.

When pitting corrosion prevails, the measured loss of electrode mass  $\Delta m$  within time interval  $T$  can be treated as a parameter that represents intensity of pit generation process. According to the mentioned remark, dependence between  $\Delta m$  and parameters, that represent noise intensity, can be expected. The obtained results of electrochemical noise measurements confirm that there are some frequency components around  $f = 10^{-2}$  Hz characteristic for pitting corrosion. It can be expected that standard deviation of details limited to the frequency band around  $10^{-2}$  Hz are more strictly correlated with intensity of pitting corrosion than the standard deviations of the remaining details and approximations.

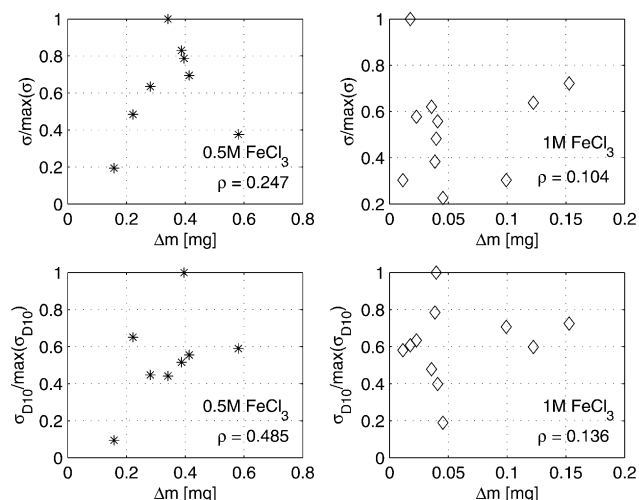

Fig. 5. Relationship between mass loss of working electrodes  $\Delta m$  and noise parameters at different  $\text{FeCl}_3$  concentrations and the time of experiment equal to  $T = 18$  h:  $\sigma$  is standard deviation of current noise,  $\sigma_{D,10}$  is standard deviation of the 10th detail of current noise decomposed by applying Daubechies mother wavelet of the fifth order.

A linear correlation between values of  $\Delta m$ , measured after the same for each electrode set time interval  $T = 18$  h, and the standard deviation  $\sigma_{D,i}$  ( $i = 1, 2, \dots, I$ ) of different details of the decomposed current and voltage noise was investigated. The most significant value of correlation coefficient  $\rho$  was obtained for  $\Delta m$  and the standard deviation  $\sigma_{D,10}$  of the 10th component of current noise (Fig. 5) [10]. The mentioned 10th component represents mainly intensity of the observed transients around frequency  $f = f_s/2/2^{10} \approx 0.4 \times 10^{-2}$  Hz. Lower correlation was observed between  $\Delta m$  and standard deviation  $\sigma$  of the recorded current noise.

Greater values of  $\rho$  were observed for a 0.5 M solution of  $\text{FeCl}_3$  than for the higher concentration of  $\text{FeCl}_3$ . The recognized fact can be explained by increase in Faradaic current at higher concentration of  $\text{FeCl}_3$  that is also partially responsible for metal dissolution into electrolyte.

## 5. Conclusions

The results of electrochemical noise analysis enabled us to propose a new parameter  $\sigma_{D,i}$  for characterization of pitting corrosion intensity. The parameter is obtained by decomposition of the observed current fluctuations into  $I$  details using wavelet transform. The number  $i$  of the detail corresponds to the characteristic for the observed transients frequency  $f_c = 1/(2\pi\tau)$ .

The strongest correlation between  $\Delta m$  and  $\sigma_{D,i}$  can be rationally best explained by the fact that  $\sigma_{D,i}$  represents the intensity of transients related to pitting corrosion processes and excludes other noise components. Such

conclusion does not assume any conditions on the process of characteristic transient generation. It can be also suspected that similar correlation can be found when pitting corrosion occurs in other metals. It is worth adding that  $\sigma_{D,i}$  can be calculated automatically by finding the roll-off frequency of the current noise power spectral density  $S_i(f)$ .

### Acknowledgements

This work was financed by KBN grant number 8T10C05215.

### References

- [1] J. Smulko, K. Darowicki, P. Wysocki, Pol. J. Chem. 72 (1998) 177.
- [2] R.G. Kelly, M.E. Inman, J.L. Hudson, in: J.R. Kerans, J.R. Scully, P.R. Roberge, D.L. Reichert, J.L. Dawson (Eds.), Electrochemical Noise Measurement for Corrosion Applications, ASTM, Philadelphia, PA, 1996.
- [3] C.C. Lee, F. Mansfeld, Corros. Sci. 40 (1998) 959.
- [4] J.L. Dawson, in: J.R. Kerans, J.R. Scully, P.R. Roberge, D.L. Reichert, J.L. Dawson (Eds.), Electrochemical Noise Measurement for Corrosion Applications, ASTM, Philadelphia, PA, 1996.
- [5] F. Mansfeld, H. Xiao, in: J.R. Kerans, J.R. Scully, P.R. Roberge, D.L. Reichert, J.L. Dawson (Eds.), Electrochemical Noise Measurement for Corrosion Applications, ASTM, Philadelphia, PA, 1996.
- [6] A. Aballe, A.M. Bethencourt, F.J. Botana, M. Marcos, Electrochim. Acta 44 (1999) 4805.
- [7] S. Mallat, Trans. Am. Math. Soc. 315 (1989) 69.
- [8] S. Quian, D. Chen, Joint Time-Frequency Analysis, Methods and Applications, Prentice-Hall, Englewood Cliffs, NJ, 1996.
- [9] M. Mitsi, Y. Mitsi, G. Oppenheim, J.M. Poggi, Wavelet Toolbox for Use with Matlab. Users Guide, Math Works Inc, 1996.
- [10] J.S. Bendat, A.G. Piersol, Random Data Analysis and Measurement Procedures, Wiley, New York, 2001.

