

Power electronic systems as a crucial part of Smart Grid infrastructure – a survey

G. BENYSEK¹, M.P. KAZMIERKOWSKI², J. POPCZYK³, and R. STRZELECKI^{4,5*}

¹ Institute of Electrical Engineering, University of Zielona Góra, 50 Podgórna St., 65-246 Zielona Góra, Poland

² Institute of Control and Industrial Electronics, Warsaw University of Technology, 75 Koszykowa St., 00-662 Warsaw, Poland

³ Institute of Power Systems and Control, The Silesian University of Technology, 2 Krzywoustego St., 44-100 Gliwice, Poland

⁴ Electrotechnical Institute, 28 Pożaryskiego St., 04-703 Warsaw, Poland

⁵ Gdynia Maritime University, 81-87 Morska St. 81-225 Gdynia, Poland

Abstract. This article gives a tutorial overview of the most important issues related to the use of power electronic systems in power engineering, with respect to the urgent need for modernization of existing grids in the direction of intelligent networks. The main problems and conditions bound up with the construction of Smart Grids and the location, as well as functioning in them of the most important power electronic systems are presented here. Special attention is directed therein to the potential possibilities of so-called ‘smart’ transformers and V2G and V2H technologies.

Key words: power electronics, Smart Grid, converter, power control, power conditioning.

1. Introduction

Currently, at the beginning of the new decade, in the field of power generation there are taking place such changes which in other areas of the economy were experienced in the world within the years 1970s and 1980s. In the meantime a fundamental transition has taken place from an industrial to a post-industrial epoch – the source of national income of developed countries has changed, namely it has been transferred from the production sector to the services sector. Such a transition is also currently occurring in power engineering, where the main focus is also being transferred from the area of power generation to the area of its distribution and management.

There are many factors, apart from EU regulations, which accelerate the aforementioned changes in power engineering. They are, in particular, the global growth of investments in Renewable Energy Resources (RES) and other Distributed Energy Systems (DES), surpassing even 40% annually [1], serving which is the Smart Grid infrastructure itself. In Poland additional factors are also the inefficiency of large scale energy investment, the explosive growth in production and deployment of DES and industry connected with Information and Communication Technology (ICT), as well as the change from a client economics base to a consumer one (prosumer). The increasing grid failures is also a decisive factor, which stimulate prosumers, boroughs, and cities into action on building their own projects for the security of energy networks.

The aim of this article is to discuss and review the potential which the Smart Grid infrastructure brings, with particular reference to the place, role and possibilities for the application of power electronic systems. An additional aim is to present selected novel solutions for devices and systems: power electronic ‘smart’ transformers and V2G and V2H technologies intended for Smart Grids.

2. Problems, conditions and tasks of Smart Grids

2.1. Smart Grids for social know-how or for power corporations? In the context of a knowledge society Smart Grid this means above all: micro-grids of intelligent prosumers (including intelligent meters), mini-grids of boroughs, city grids, grids for realizing new avenues of value – including electric cars. Such a conception implies a reversal of the method of building a Smart Grid in relation to that which national power engineering corporations are planning. Namely, the current national conceptions (those which the Energy Regulatory Office and the PSE-Operator are intensely engaged in) depend on building a ‘total’ (top-down) AMI (Advanced Metering Infrastructure) system of measuring, in practice only electricity, embracing all end-users (more than 16 M in Poland). Of course, one can bet that there are interested parties in such a system: a) powerful interest groups concentrated in the industry of calibration devices and data communication, b) transmission operators and also distribution operators in the electrical energy market. On the other hand, such a system, very expensive, but also without any precisely defined functionality, not only gives no benefits to consumers but has a huge potential for being transformed into a consumer ‘pressure’ system by the operators (into a system characterised by ‘directives’ – a so-called Big Brother syndrome). The risk which is here referred to is confirmed by the Italian experience. Namely, Italy realised an AMI system encompassing more than 30 M electrical energy consumers. A study which was carried out with the aim of defining the benefits of building the system show that no more than 4% of consumers are aware of the potential possibilities of the system (that does not mean that they have any kind of benefits from it). For this reason the Polish strategy should rest

*e-mail: rstrzele@am.gdynia.pl

on the building of a Smart Grid infrastructure for the needs of prosumers, that is, for the needs of managing distributed generation resources (moreover, polygenerational ones), and to a lesser degree for the needs of traditional consumers. Consequently, Poland should create a broad environment in the area of development of precisely such an infrastructure, in particular with institutions which have already published a program assisting the development of a Smart Grid (to such institutions belong, e.g., The National Fund for Environmental Protection and Water Management, which in the coming years will spend 500 M zloty on this purpose).

2.2. The need to rationalise the place and role of the Smart Grid. Table 1 shows the designated areas and spheres of interest for the desired place and role of the Smart Grid infrastructure. From this understanding results a need for changes in the power system. Under no circumstances can a Smart Grid infrastructure serve to reinforce the character of corporate power engineering, i.e., in particular, the role of the transmission system operator must be restricted. The Smart Grid infrastructure should serve the market and democracy, i.e., it should help diverse remote development.

2.3. Smart Grid and the intensification of exploitation of grid resources (intensification of utilization of existing electrical power system). In the coming years, in Poland, there should be one of the most important areas of exploitation of the Smart Grid infrastructure. There are two causes justifying such a thesis. Firstly, there are various 'deficits' linked with the limitation of investments in the power system segment (limitation of capital, location and others); these deficits will prevent the continuation of the hitherto model of development in the electrical power system. Secondly, there are possibilities resulting from the technological delaying of the electrical power system; as a consequence it is possible to use many technologies/concepts for the object of intensive utilization of these grids. The most important significance comes from the point of view of utilization the dynamic capacity of the overhead lines, for which purpose the basis is the identification of the prevailing weather conditions (wind, insulation, temperature), decisive for the thermal loading of the overhead cables. In this area the role and significance of power electronic devices as controllers/conditioners of electric energy are unquestionable.

2.4. Smart Grid and intelligent zero-energy house. Such a house is a technology, which in conformity with the directive 2010/31/WE, concerning certification of buildings, will be in use after 2018 in respect to new buildings for public use, and after 2020, in respect to all buildings. To promote this technology we should already be directed to the ICT industry, which in Poland is the fastest developing industry in Europe and has a chance to further develop its competitiveness. Of course, in this case it is not only restricted to measuring-charging systems in the electric energy market. The criteria for development in this industry must encompass such areas as: the business of device suppliers, the reliability/quality of the electric energy supply to traditional consumers, the value which represents itself more than the cost of infrastructure for prosumers, in which also counts the creation of a new life style for them. Equally in this case it is difficult to talk about an intelligent house without electric energy controllers, which are power electronic devices.

2.5. Smart Grid, transport and storage technologies (electric cars). In Sec. 6 there is presented a detailed concept and the possibilities which are gained by including electric cars in the electric energy economy (with the help of the Smart Grid infrastructure). Here only a short account of the characteristics of the concept in two particular cases is discussed. Firstly, a storage segment is created by electric cars, with a battery capacity unit of about 40–60 kWh, working in charging and driving modes. This is a segment which is developed under the influence of the directive 2009/28/WE. If we optimistically assume that in Poland in 2020 there will be 1 M electric cars, the storage potential of the segment (cautiously estimated) comes to about 80 MWh/day (at an annual car use of 20 000 km). This potential can be developed progressively beginning as soon as in 2012. Secondly, the storage segment created by electric cars, in the first case, but working in the charging mode, can drive and power the grids/consumers. Such a solution has a DSR (Demand Side Response) potential many times bigger. There is a powerful potential in this depending on the speed of car charging. Therefore also, as soon as in future, it depends on fast charging stations and on exchangeable battery panels. It is estimated that in this case the potential DSR for Poland in 2020 comes to as much as ± 400 GWh/day (on the assumption that batteries can be recharged once a day). The power electronics is of course also essential in the exploitation of this potential.

Table 1
Place and role of Smart Grid

Designated area	Sphere of interest			
	prosumer	Local Government	electric power network RES/DES	prosumer
DSM	individual security, comfort, consumer economics	critical infrastructure, balanced growth	production of devices, design, installation, franchising network	system services market at the level of DSO
DG				
DER				
Grid resources	–	–	–	intensification of use (basic DSO business)

Legend: DSM - Demand Side Management, DG - Distributed Generation, DSR - Demand Side Response, DSO - Distributing System Operator.

3. Smart electrical energy networks – technical concept

Over last years, Electrical Energy (EE) consumption has continually grown, on the other hand, at the same time, investment in the TD (Transmission and Distribution) infrastructure has increasingly declined. Traditional solutions for upgrading the electrical system infrastructure have been primarily in the form of new power plants, new transmission lines, substations, and associated equipment. However, as experience has proven, the process of authorizing, locating, and constructing new transmission lines has become extremely difficult, expensive and time-consuming. As a result the power grid is under stress, resulting in compromised reliability and higher energy costs [2]. Despite the aforementioned problems, the system reliability is untouchable and cannot be compromised. To overcome this problem, grid operators move away from radial systems towards networked ones, however this degrades controllability of the network, because current flows along particular lines cannot be easily controlled. The situation is even worse, if a incident such as loss of a line results in overload, increasing the possibility of a blackout. Additional-

ly, rapid load growth leads to jamming on key lines which, in consequence, leads to an inefficient operation of energy markets.

The answer seems to lie in transforming the current Energy Power System (EPS) into smart Electrical Energy Network (EEN), also called Smart Grid. Future smart EENs will be strong, more flexible, reliable, self-healing, fully controllable with an asset of efficient use and will be a platform enabling the coexistence of smart-self-controlling grids with great amounts of Distributed Generations (DG) and large-scale centralized power plants [3, 4]. The need for modifications, demands to remove the barriers to the large-scale exploitation and integration of DGs and other actors, will necessitate the research, development of new innovative technologies from generation, transmission and distribution to communication tools, with far more sensors than presently [5]. Thus, this is envisaged that Flexible AC or DC Transmission/Distribution System, Custom Power Systems (CUPS), Energy Storage Systems (ESS) and DG, smart end-user appliances together with communications will be at the heart of the future Smart Grids, see Fig. 1.

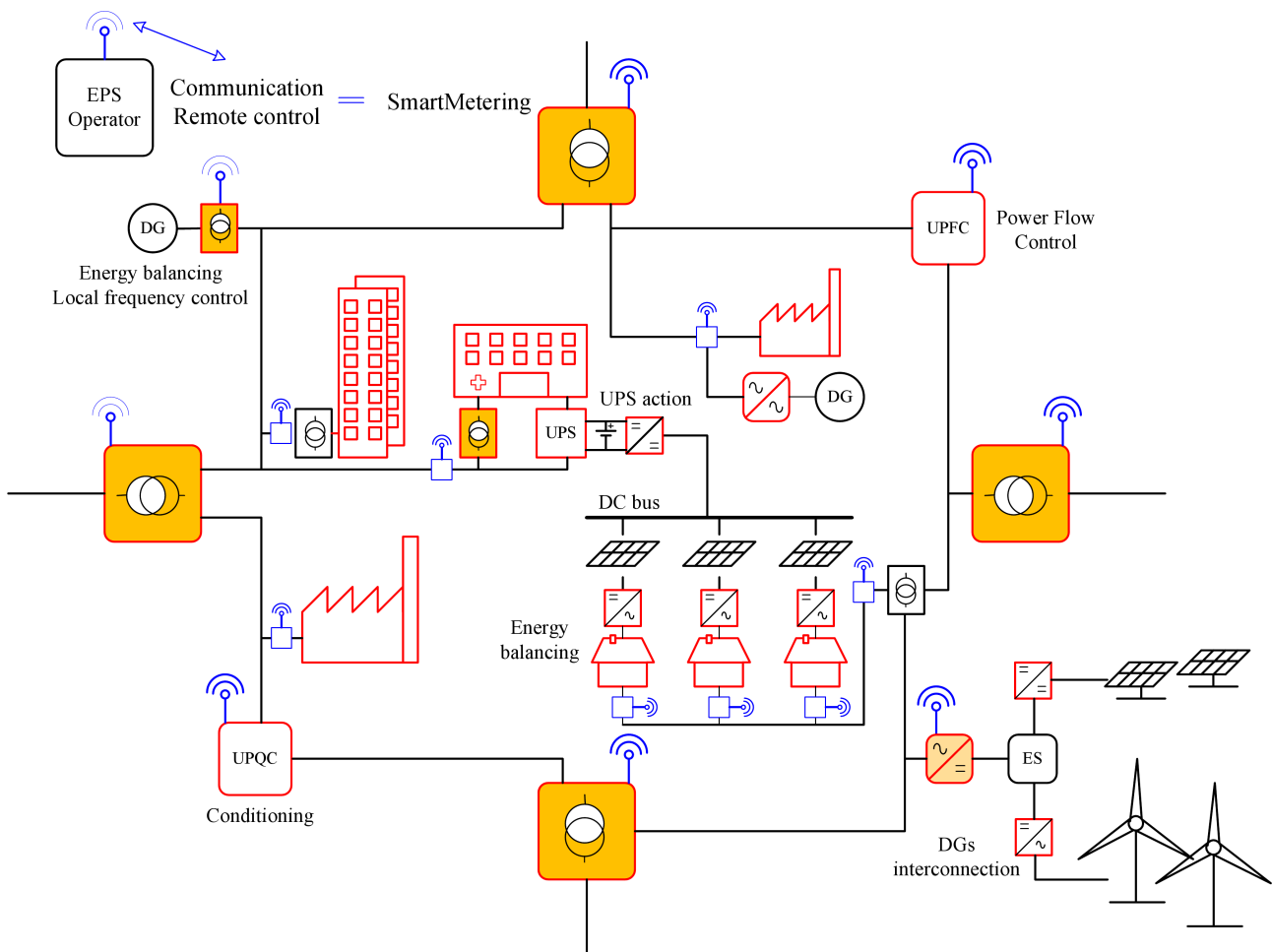

Fig. 1. SmartGrid with SmartMetering & SmartBuilding technology

Smart Grid allows the customer to take an active role in the supply of electricity, which can help the electricity system respond to equipment failures, weather-related emergencies, and other conditions. At present, a system operator must maintain enough excess generating capacity online or quickly available to continue supplying system load if a large generating unit or transmission line fails. In the Smart Grids, much of that reserve could be provided by EPS or small DG, ESS units located near end-user sites. Summarizing, a modernized smart grid would create EPS that:

- reduces peak loads and generate reserve margins;
- deletes capital costs of new T&D infrastructure as well as generating plants;
- lowers T&D line losses together with operation and maintenance costs;
- redirects power flows, changes load patterns, improves voltage profiles and stability;
- enables loads ESS and DG to participate in system operations;
- through extensive monitoring, quick communications, and feedback control of operations, it has much more information about system rising problems before they affect service;
- provides system utilities with advanced visualization tools to enhance their ability to oversee the system.

4. Modern power electronics arrangements in EEN

4.1. Application area. The use of Power Electronics (PE) arrangements in EENs can be generally divided into: a) electrical energy transmission system, b) electrical energy distribution system. The transmission system is composed basically of two complementary technologies for controlling the transmission of energy [3, 6, 7]: a) with conversion to DC current – HVDC devices; b) directly – FACTS devices. A general comparison of these devices is illustrated in Figs. 2 and 3.

An advantage of HVDC devices is the capability to transmit energy between systems of various frequencies. However, in the case of conventional HVDC, i.e., with the use of SCR thyristors, it is necessary to use large filters and there is no possibility of supplying power to end-users on the side from which the source is disconnected. This drawback does not occur when using modern devices, such as GTO thyristors or IGBT transistors. Here, one should note that with HVDC devices the entire energy from one system flows into the other through converters. As a result of this the cost is high, even in single-station installations. While in FACTS devices, such as:

- SVC (Static Var Compensator) and STATCOM (Static Synchronous Compensator),
- TCSC (Thyristor Controlled Series Compensator), TSSC (Thyristor Switched Series Compensator) and SSSC (Static Synchronous Series Compensator),
- SPS (Static Phase Shifter),
- UPFC (Unified Power Flow Controller),

only part of the power flows through the power converter.

Such devices can be applied, however, to the control of EE flow only in AC systems with a single frequency.

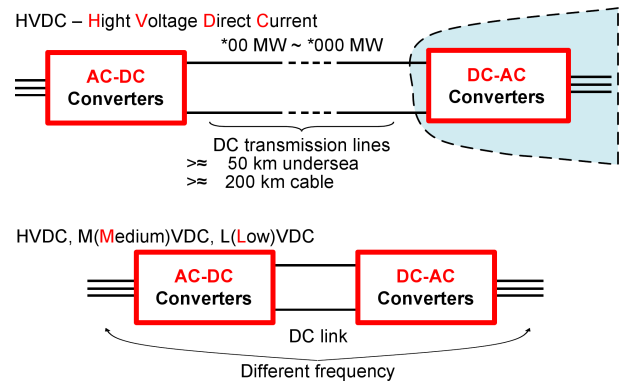

Fig. 2. PE arrangements in DC transmission systems

FACTS – Flexible Alternating Current Transmission System

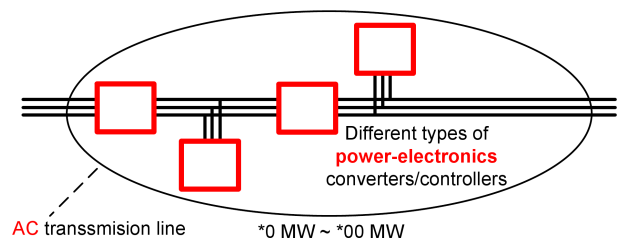

Fig. 3. PE arrangements in AC transmission systems

A decidedly greater variety of PE arrangements occurs in distribution systems. In these systems PE converters/controllers are applied in general to:

- matching parameters and coupling of distributed sources with power lines or local end-users, and controlling consumption of EE with these sources (Fig. 4),
- matching parameters and coupling of energy storage with power lines, and controlling the exchange of energy between storage systems and power lines (Fig. 5),
- improving the quality of the power supply, among other things: compensation of sags and swells, asymmetry and distortions of supply voltage, as well as compensation for distortion, asymmetry and phase shift in load current (Fig. 5).

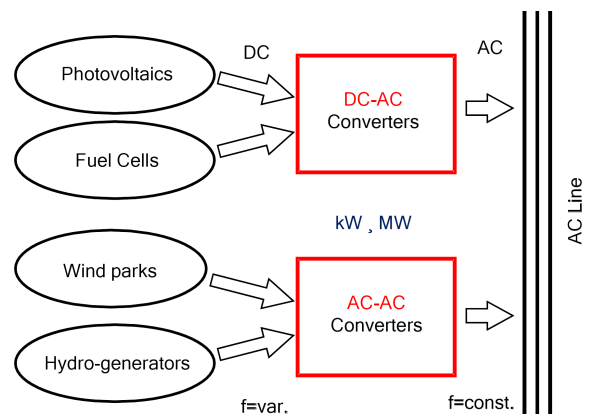

Fig. 4. PE arrangements in alternative generation systems

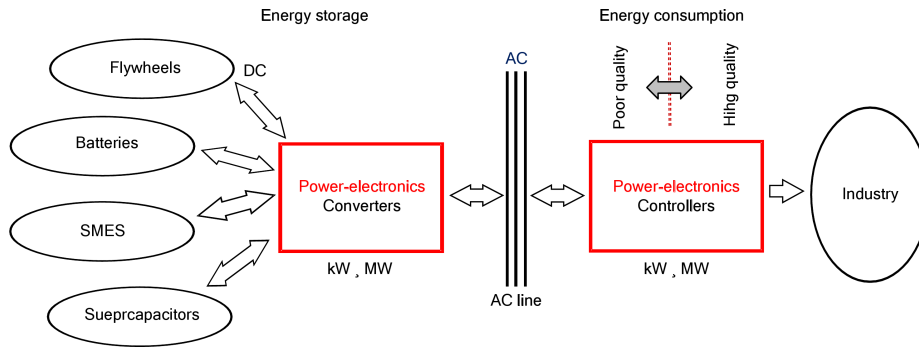

Fig. 5. PE arrangements in storage systems

4.2. Examples of application. Figure 6 illustrates the most important areas of use of PE arrangements in EEN, at various levels of power. A further discussion of these areas, with reference to objects of this paper and common characteristics of applied solutions, are limited to:

- wind installations,
- energy storage and of low-voltage sources,
- network couplers and installations improving energy quality.

4.3. Wind installations. The most frequent application of PE arrangements in wind installations is in generators (Fig. 7) [8, 9]. In the beginning the most commonly applied device

was the squirrel cage induction machine (IM) connected directly to an EEN, and PE arrangements used solely in a simple connection-starting device. As a result, in such installations there occurs a transfer of the pulsation of the wind power to the power network and, moreover, there is no means of direct control of the active and passive power. The significance of such a control, desirable for the control of voltage and frequency in an EEN, increases along with the rise in power [10]. As a result of this, generators with squirrel cage induction machines connected directly to an EEN are sporadically applied to new installations of large power. On account of power losses and limited means of regulation, generators with Wound Rotor Induction Machines (WRIM) and PE adjustable resistance in the rotor circuit are also rarely installed [11].

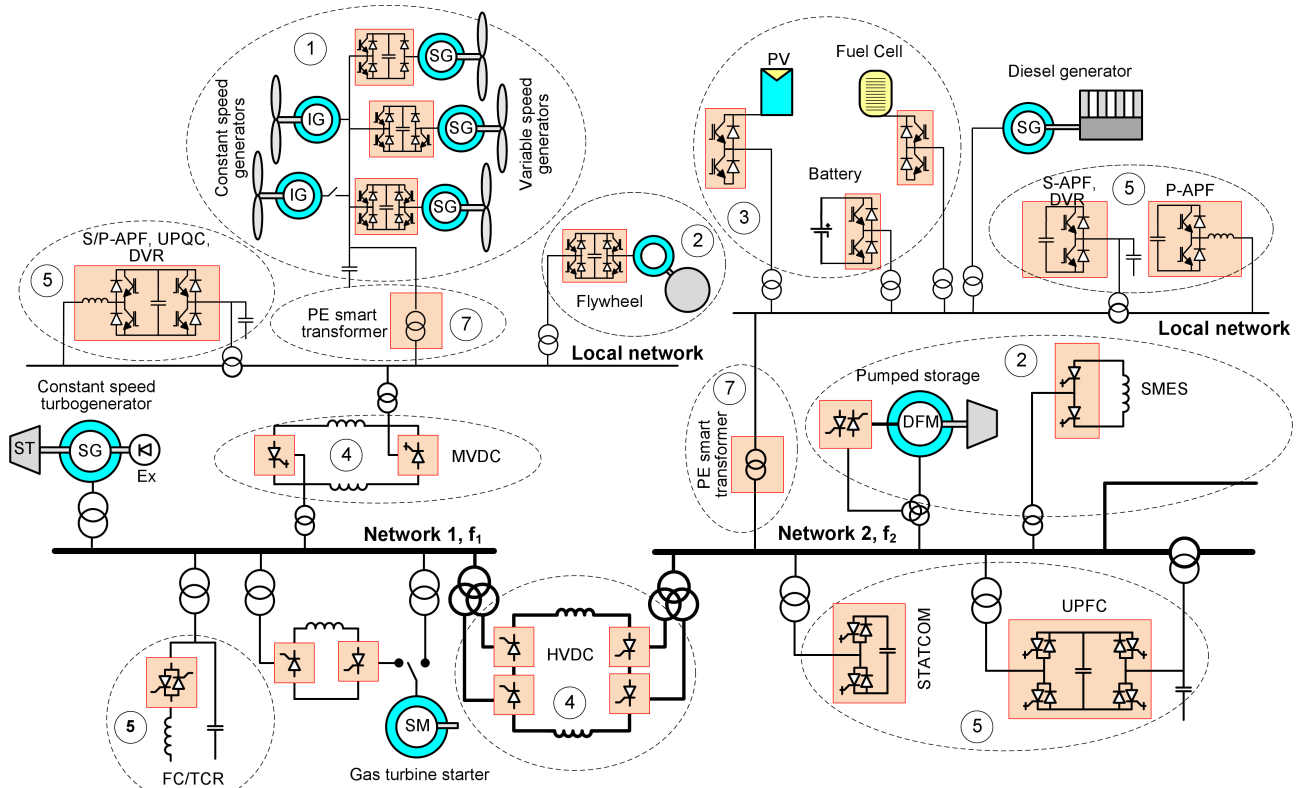

Fig. 6. Area of application of PE arrangements in EEN: 1) wind generators, 2) energy storage, 3) power supply systems from low-voltage sources, 4) network couplers, 5) devices for improvement of energy quality, 6) devices for control of energy delivery

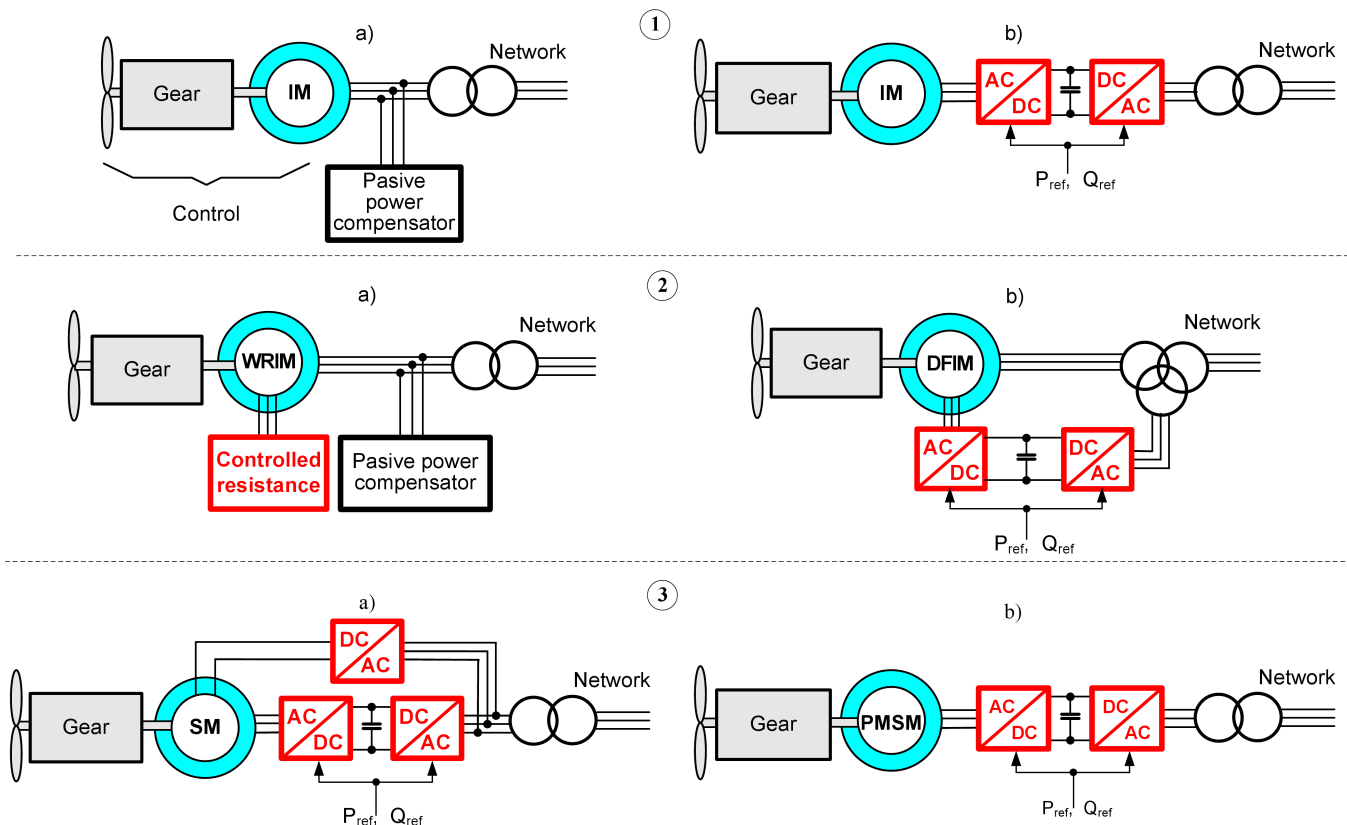

Fig. 7. Basic types of wind turbine generators: 1) with squirrel cage induction machines (a – fixed speed, b – variable speed), 2) with wounded rotor induction machines (a – fixed speed, b – variable speed), 3) with synchronous machines (a – external magnetized, b – permanent magnets)

Currently in the world, mostly are used:

- Double Feed wound rotor Induction Machines (DFIM) with an AC-DC/DC-AC converter in the rotor circuit (Fig. 7.2b),
- Synchronous Machines (SM) with an AC-DC/DC-AC converter in the main line and an AC-DC/DC-AC converter in the exciter circuit (Fig. 7.3a),
- Permanent Magnet Synchronous Machine (PMSM) and AC-DC/DC-AC converter in main line (Fig. 7.3b).

There are also generators with squirrel cage induction machines (IM) but with self-excitation and an AC-DC/DC-AC converter in the main line, designed for full power (Fig. 7.1b) [11–15]. All these solutions, although more costly than the ones applied at the beginning of the development of wind power in Poland, are characterized by much better regulatory qualities, among which are: the capability of adjusting active and passive power; the capability of operating at varying shaft rotation speeds, rapid reaction to change of wind conditions (0.5–1 ms); avoiding influence and resistance to deteriorating quality of EE in an EEN; and the capability to work in islanding mode [10]. These aspects support the implementation of the vector control method applied originally to the motor drives [16–19], as well as the Maximum Power Point Tracking (MPPT) algorithms enabling the full use of the available wind

energy [9, 12]. Multipolar SM and PMSM permit through this the elimination of a mechanical transmission system, which raises the reliability of the turbine.

Heavy duty PE converters are equally employed in wind farms, taking care of at least a few connected turbines situated close by. The configuration of farms is equally dependent on the kind of generator as well as the type of converter used and the topology of the EEN [8–10]. A typical example is the connection of turbines with generators, shown in Fig. 8.

On a farm as shown in Fig. 8.1, having groups of turbines with squirrel cage induction machines, the D-STATCOM (or SVC) supplies passive power to the machine and assists in maintaining the voltage profile in the network. Unfortunately this farm does not lend itself to individual control of the turbine power or control of the circulating power between turbines. It is equally impossible to eliminate the phenomenon of wind power pulses from the network. The latter drawback is, however, removed from the farm presented in Fig. 8.2, since the DC link (AC-DC/DC-AC converter) allows the control of not only passive power and network voltage profile, but also the direct control of active power supplied to the network. This solution creates also the interesting option of connecting a farm located at a distance from the existing EPN with the DC line.

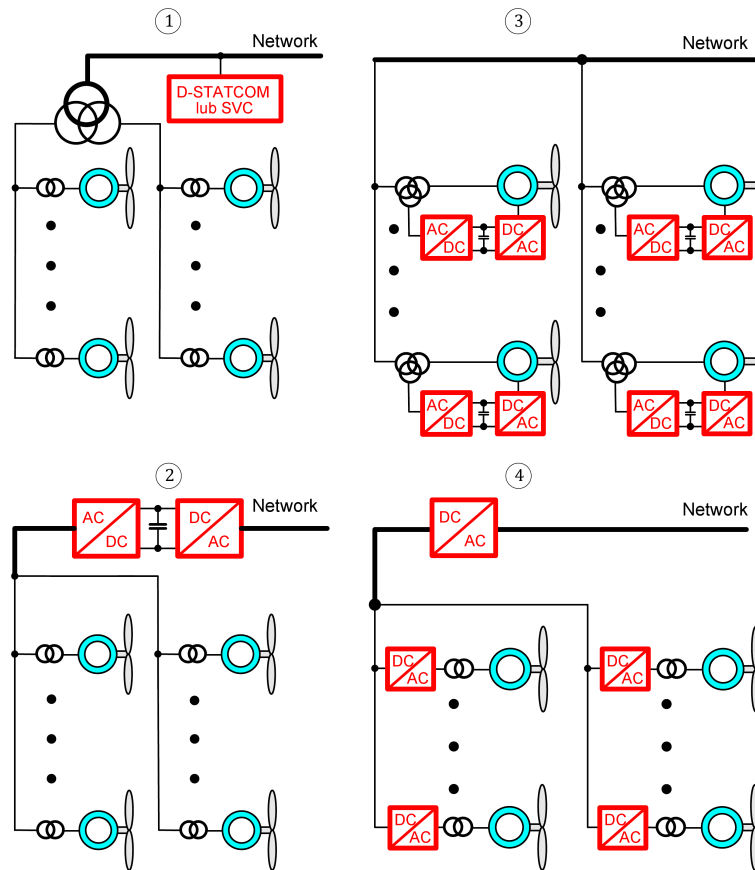

Fig. 8. Typical connection of turbines with induction machines used in wind farms: 1) with passive power compensator (D-STATCOM or SVC), 2) with common DC link to the power network, 3) with internal DC network and individual control of power, 4) with individual control of power

An extended concept for use of DC couplers in wind farms is illustrated in the configuration presented in Fig. 8.3. The rectifier part of the heavy duty AC-DC/DC-AC converter, Fig. 8.2, is divided into particular turbines, forming in this way an internal DC network, as well as enabling individual control of turbine power. In this respect it is noteworthy that matching turbines to a DC network is significantly easier than to an AC network, because the DC network requires only one control parameter (amplitude), while the AC network requires as many as three (amplitude, frequency and phase). Moreover, dividing a DC network simplifies the connection of energy storage devices. For this reason AC-DC/DC-AC converters are used on farms, in general, only in such cases where they have already been integrated into the turbine by the manufacturer. Most often this concerns turbines in which there are generators with DFIM machines, Fig. 8.4, or PMSM. AC-DC/DC-AC converters for individual turbines can be equally justified in cases of a very high power.

4.4. Energy storage and low-voltage source systems.

Energy storage, in the form of batteries, are widely used in back-up power supplies. In such devices flywheels exploit greater power [3, 20], amassing kinetic energy. An example of a kinetic resource, constructed in the form of a container, is shown in Fig. 9. Quite small fast-rotating kinetic storage resources are connected to an internal DC bus through an AC-DC con-

verter, and only then through a DC-AC converter to an AC line. It should be emphasized that the greatest difficulty in constructing a modern kinetic storage is tied not to power-electronics, but to high-speed flywheel rotation technology (60000–90000 RPM).

Batteries, flywheels and other storage, such as: water containers, hydrogen systems, heat energy storage, supercapacitors, superconductive storage or compressed air tanks are also used in distributed sources [3, 21]. The goal is to improve the availability of these sources, i.e., the amelioration, or even elimination of the influence of external conditions (weather) on the power temporarily supplied to the EPN. For the connection of such resources to the network various PE arrangements are employed.

Figure 10 illustrates an example of the exploitation of an energy storage unit for the compensation of active power pulsations caused by the fluctuations of the wind energy. The degree of compensation depends on the size and dynamic qualities of the energy storage as well as the control algorithm used [22]. This in turn has an influence on the power of the converter, the type which is chosen with respect to bidirectional energy flow and the kind of energy storage. For example, for batteries it will be an AC-DC converter, and for a flywheel with an AC motor, an AC-AC converter. The power of the converter depends, too, on its additional functions, e.g., its passive power compensation efficiency.

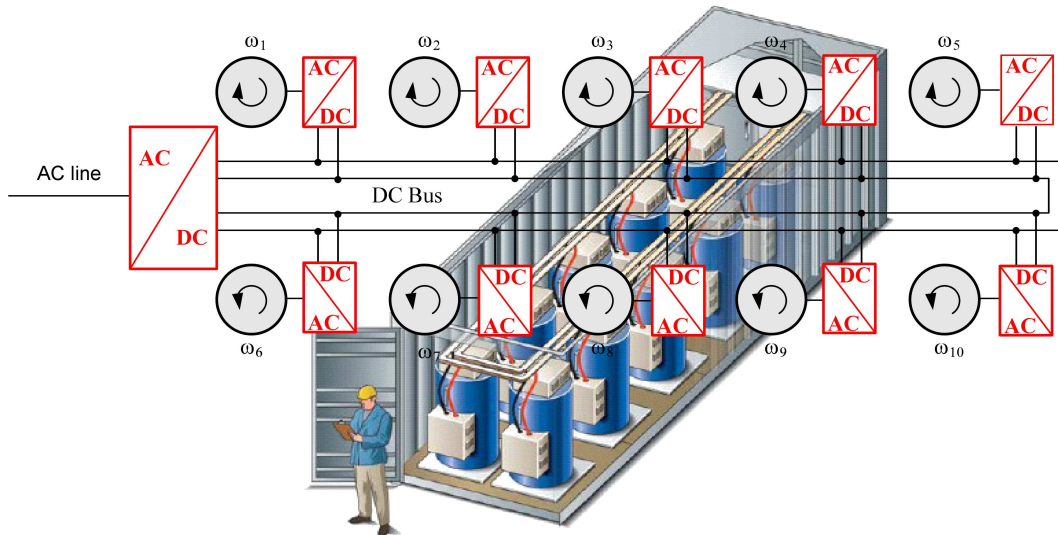

Fig. 9. Example of a kinetic storage container

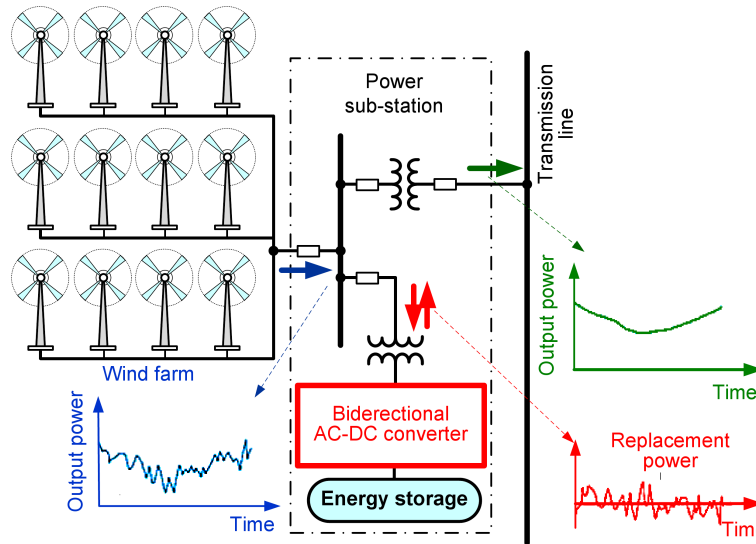

Fig. 10. Implementation of energy storage for the compensation of active power pulsations on output of wind farms

In the case of the exploitation of energy storage and low-voltage sources, the configuration of the source and the means of matching the voltage levels has a decisive influence on the qualities of the chosen solution [23]. Typical examples here would be a power supply with a photovoltaic cell (PV) and a fuel cell (FC) [24–26], in spite of the fact that FC, in contrast to energy storage, do not have the capability for bidirectional energy flow.

PV systems are differentiated by three basic connection configurations, illustrated in Fig. 11. The most universal, though at the same time the most demanding in respect to the PE arrangement, is a configuration with a modestly sized DC-AC converter integrated into the PV module. The converter should be characterized by: very high efficiency and minimal size, increased voltage cell and sinusoidal output voltage as well as the ability to work with parallel connections. These requirements enable the connection to modern PE converters

[27–31] realized on the basis of currently available PE components [32–34]. In conventionally configured PV systems, generally of greater power, an internal DC bus is frequently used (Fig. 12). Its purpose is similar to that of the case of the wind farm illustrated in Fig. 8.3. A DC bus also permits easier galvanic isolation of the PV cell with the help of high frequency transformers Fig. 12.1, and in addition, may be an integrated part of the internal DC micro-network [35–36].

In a similar way to the PV system, with the use of a genuine PI and DC bus, systems with FC elements are likewise configured [26, 37]. In this case, taking into consideration the soft output characteristics and low voltage of individual cells, the connection of fuel cells in the stack is of decisive significance to the required output voltage and load capabilities. Figure 13 illustrates example configurations of fuel cell connections in series and parallel stacks as well as current-voltage characteristics of these stacks.

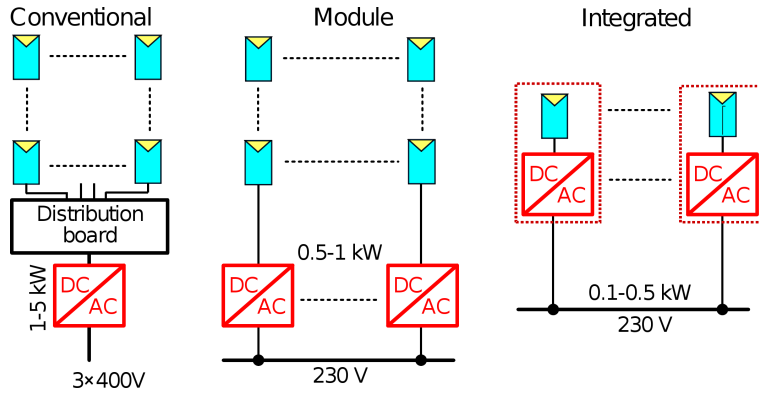

Fig. 11. Typical configurations of power supply systems with PV cells

	Primary side AC-DC Converter	DC bus	Secondary side DC-AC Converter
Reactive Power	$Q_1 = \frac{V_{F1} \cdot V_{S1}}{X_1} \cdot \cos \delta_1 - \frac{V_{F1}^2}{X_1}$	0	$Q_2 = \frac{V_{F2} \cdot V_{S2}}{X_2} \cdot \cos \delta_2 - \frac{V_{F2}^2}{X_2}$
Active Power	$P_1 = V_{F1} \cdot V_{S1} \cdot \sin \delta_1 / X_1$	$P_1 = P_{DC} = V_{DC1} \cdot I_{DC} = V_{DC2} \cdot I_{DC} = -P_2$	$P_2 = V_{F2} \cdot V_{S2} \cdot \sin \delta_2 / X_2$

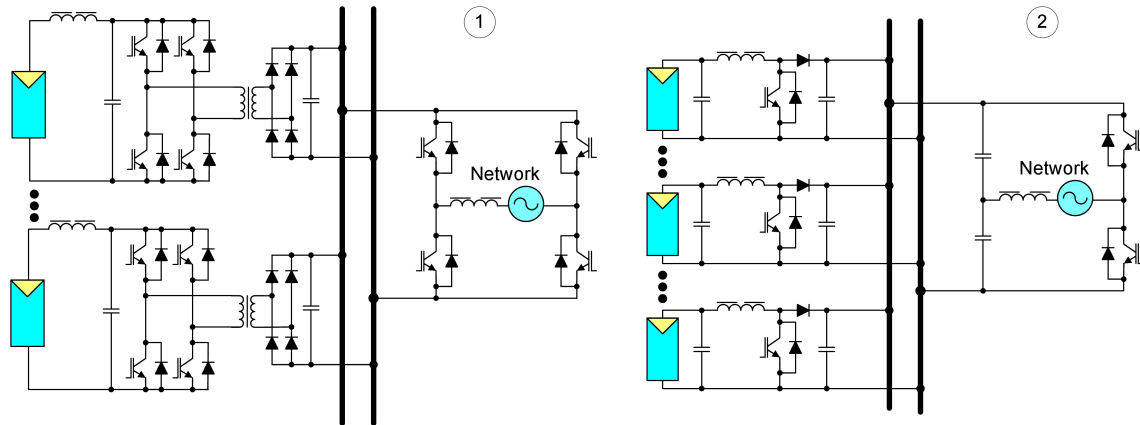

Fig. 12. Examples of functional connections of PV cells to distribution networks: 1) with HF galvanic isolation transformers, 2) without galvanic isolation

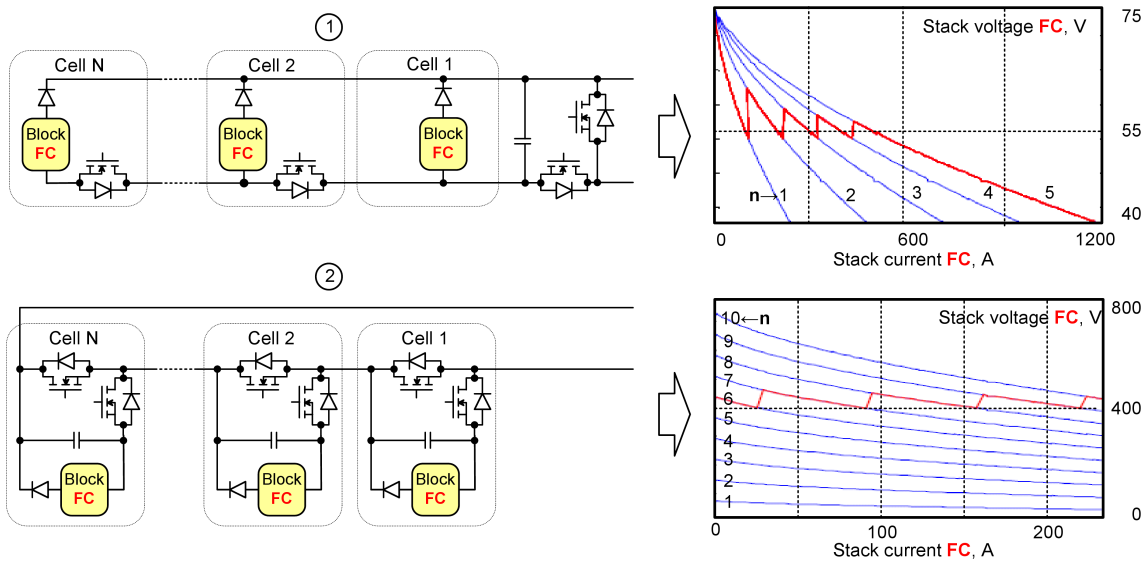

Fig. 13. Connection of FC in stacks and their characteristics: 1) parallel, 2) series

4.5. Network couplers and power quality improvement devices. PE network couplers and energy quality improvement devices have many common features with energy delivery control devices. A basic difference is in the function and location of these devices in the EEN [3–7, 38–39]. The most universal couplers are “back-to-back” type devices, composed of two fully controlled AC-DC and DC-AC converters (voltage or current), connected by a DC bus [40]. While one converter works as an inverter the second acts as a rectifier. The change in the working mode of the converter causes a change in the direction of the power flow. In so doing, always only active power flows through the DC bus, which acts as a device insensitive to frequency and phase differences in a coupled network. Furthermore, in respect of the DC bus each converter may equally independently fulfill additional functions as an EE quality improvement device, and, in the case of connecting energy storage, as a source of “interventional” power [2, 38, 39]. The basic function of a “back-to-back” coupler, where voltage converters are used, is clarified by the explanatory phasor diagrams shown in Fig. 14 and the dependencies, are shown below.

In practice “back-to-back” couplers are connected to networks by transformers [41–44]. Such connections serve, above all, matching the voltage in the AC-DC/DC-AC converters and in the network couplers. Employing transformers is also recommended in voltage matched “back-to-back” devices, e.g., when using multi-level converters [45, 46]. In this case, thanks to galvanic separation, the operational safety is increased and malfunctions are ameliorated. Moreover, transformers in parallel “back-to-back” devices enable improvement of the voltage form at the coupler’s terminals [44, 47].

Modern PE arrangements serving to couple AC and/or DC networks as well as to match distributed sources and energy storage already today enable the building of local micro-networks as a part of an smart EEN [3, 35, 36, 48]. For example if we consider the micro-network structure shown in Fig. 15, we gain a highly flexible integration of distributed sources and the capability of “plug-and-play” type functions at every level, without the necessity of implementing non-standard solutions. Here it is understood that the most effective working conditions of the power network (with a micro-network in it) occur in the case of steady loads with a power coefficient of $\lambda \approx 1$.

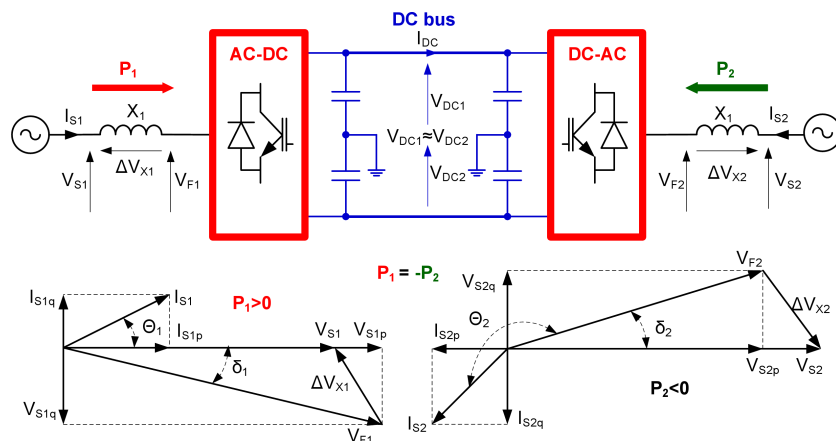

Fig. 14. Structure and working principle of “back-to-back” network coupler with intermediate direct current bus

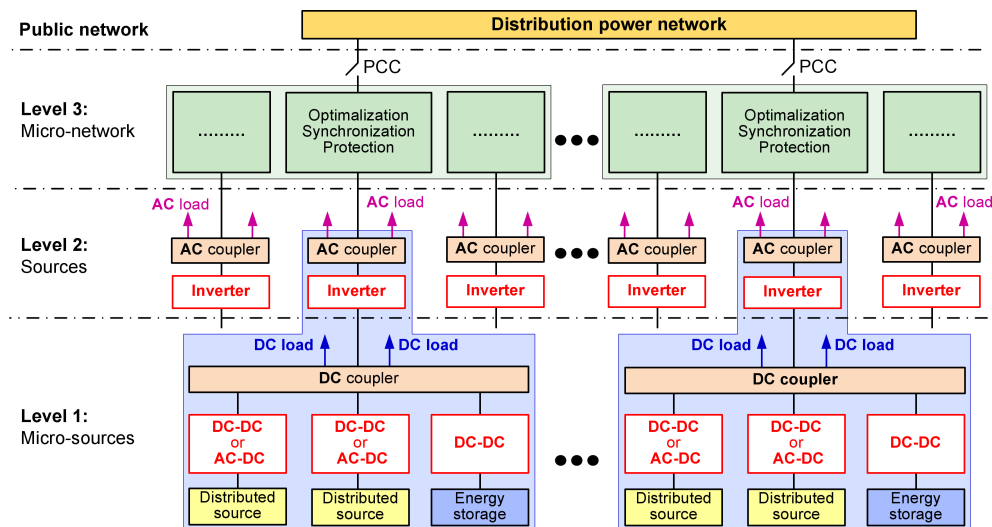

Fig. 15. Hierarchical structure of hybrid micro-networks with DC and AC couplers

With the aim of improving the coefficient $\lambda < 1$, on the output or directly on the input (load), various compensatory-filter devices are installed. Among the implemented solutions [3, 39], the most universal are active power filters (APF) [20, 49]. APF devices, depending on the control algorithm, enable a connection or selective compensation of all undesirable current components and/or voltage.

Figure 16 illustrates two basic APF devices: parallel (P-APF/Parallel-APF) and series (S-APF/ Series-APF). The P-APF device, Fig. 16.1 is primarily intended for current compensation, and the S-APF device, Fig. 16.2, for voltage compensation. Sometimes the S-AFP device is also used to force

a desired current, and the P-APF device to force a desired voltage. The choice of APF device and its use depends on the character of the load and the network, as well as on the demands concerning EE quality. In some cases, in order to achieve the required quality of EE, it is necessary to use series-parallel APF devices (Fig. 17). These devices, also called UPQC (Unified Power Quality Conditioner) [49–51], are in general constructed as integrated P-APF and S-APF connections with a common DC bus. The device in Fig. 17.3 does not have a common DC bus [52], which enables the application of multi-level DC-AC and AC-DC cascade converters [45, 46].

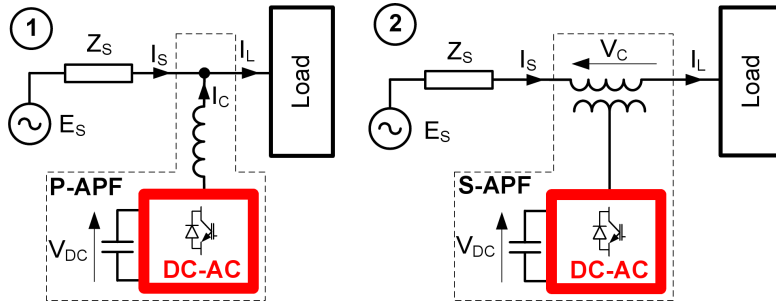

Fig. 16. Basic APF schemes: 1) parallel, 2) series

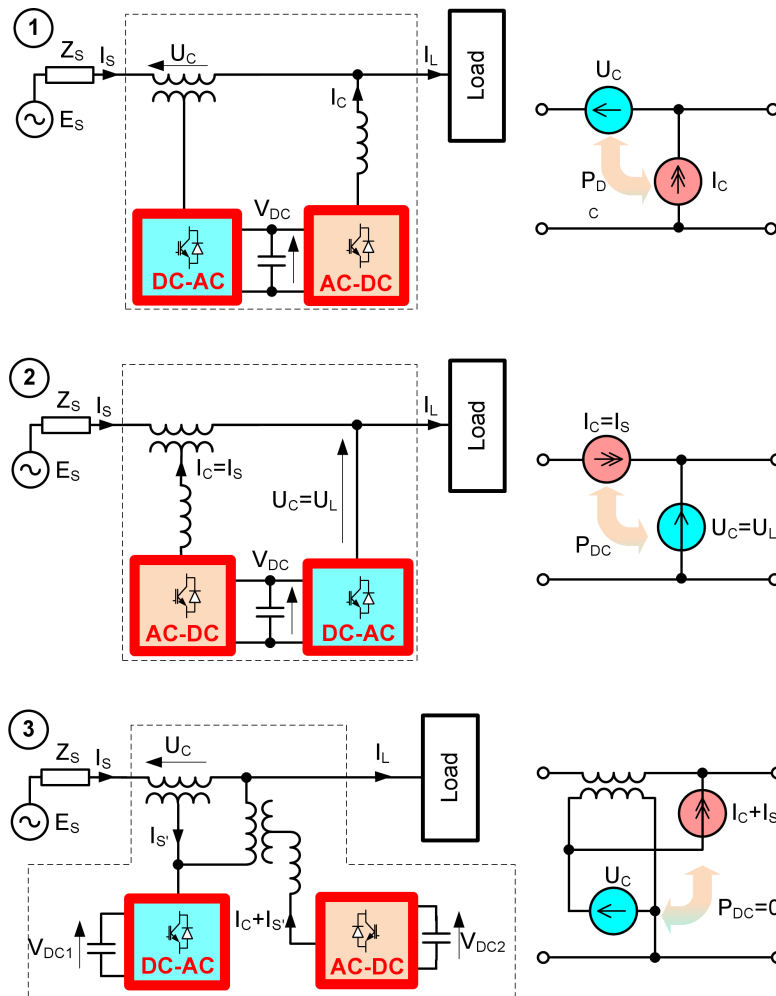

Fig. 17. Series-parallel APF devices: 1) compensatory, 2) forced, 3) without common DC bus

Dynamic voltage restoration devices (DVR – Dynamic Voltage Restorer) are a certain kind of active filter, somewhere between S-APF and UPQC [38, 39, 53–54]. Figure 18 illustrates their general construction and location in the distribution system. When there is a voltage disturbance in the power supply, the DVR device immediately restores the correct voltage, ensuring the proper power supply to sensitive loads, with the exception of situations where there is an interruption in the power supply or frequency deviation. Specifically, DVR enables compensation for voltage sags.

Due to the demands of generating or receiving active power over a relatively long period of time (even a few seconds), the DVR device (in contrast with an S-APF) is equipped with additional energy storage connected to the DC bus. Sometimes, with the aim of reducing energy storage or in situations where prolonged disturbances occur, parallel AC-AC converters are used, in a similar manner to a UPQC. There is a difference in the type of converter, which for a DVR can be a diode rectifier. Naturally it is the case here that the UP-

QC device may also function as a DVR, but such a solution is unnecessary and uneconomical. A smaller energy storage is likewise necessary in inter-line DVR devices, Fig. 18.2, which results from the possibility of exchanging active power between power lines.

Due to the demands of generating or receiving active power over a relatively long period of time (even a few seconds), the DVR device (in contrast with an S-APF) is equipped with additional energy storage connected to the DC bus. Sometimes, with the aim of reducing energy storage or in situations where prolonged disturbances occur, parallel AC-AC converters are used, in a similar manner to a UPQC. There is a difference in the type of converter, which for a DVR can be a diode rectifier. Naturally it is the case here that the UPQC device may also function as a DVR, but such a solution is unnecessary and uneconomical. A smaller energy storage is likewise necessary in inter-line DVR devices Fig. 18.2, which results from the possibility of exchanging active power between power lines.

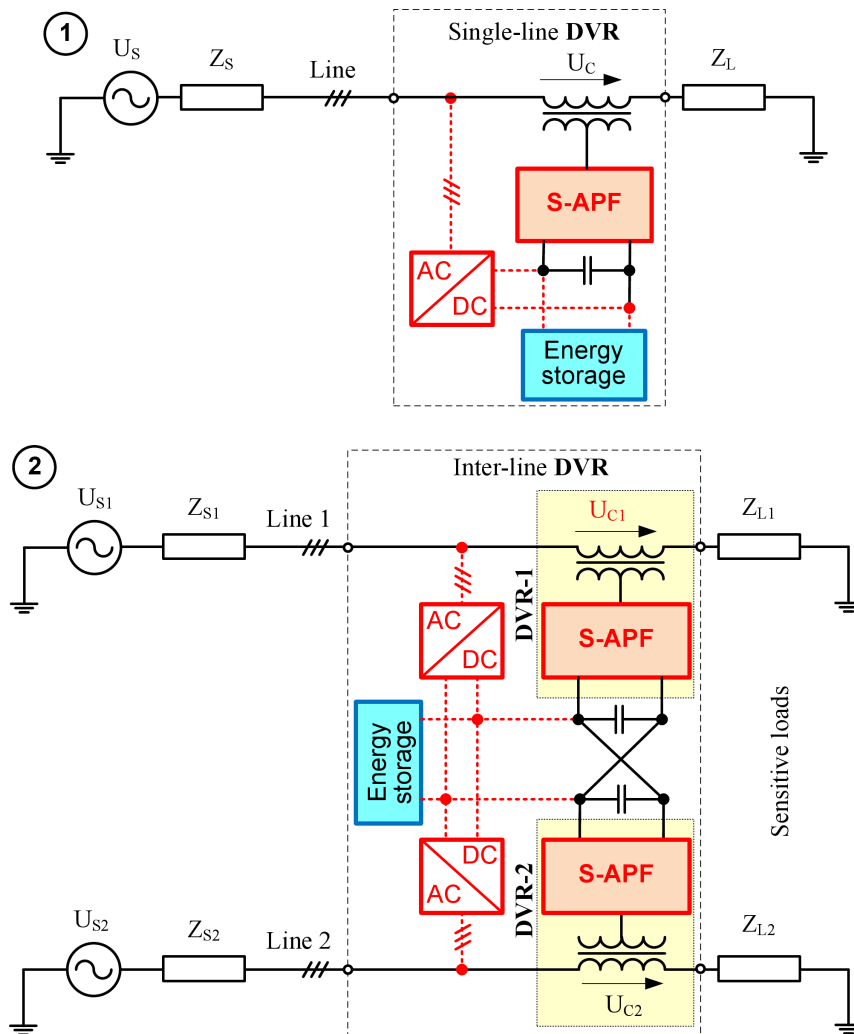

Fig. 18. Example DVR devices: 1) single-line, 2) inter-line

5. Power-electronics smart transformer

It is well known that traditional networks transformers are difficult to control as well as they increase in a significant way the size of coupling AC installations. Moreover, in no-load running they generate relatively high reactive power and may cause voltage distortion. These factors and other observed trends associated with change toward application of Smart Grids raised interest in promoting EEN Electronics Power Interconnection (EPI) for AC systems [55–57].

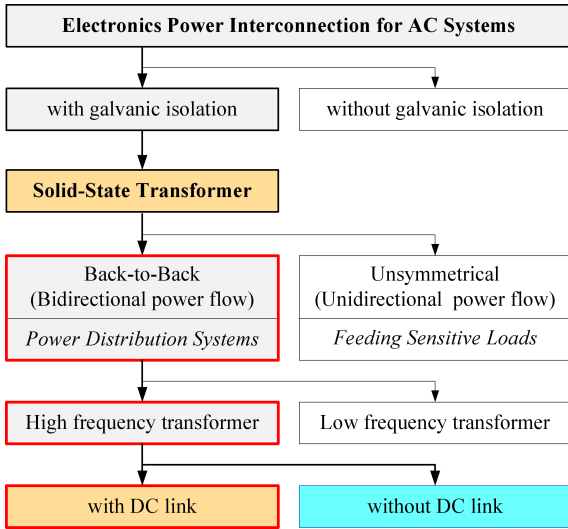

Fig. 19. Grouping of the Electronics Power Interconnection for AC Systems

Figure 19 illustrates simplified diversification of EPI for AC systems. Fit between PE arrangements and EPI first of all is based on their application. Thus any AC/AC converters (direct and indirect), as well as presented above “back-to-back”

couplers (see Fig. 14), can be applied as EPI. However, in practice, not all of the proposed solutions are efficient and acceptable. In particular, many solutions related to connecting systems LV and MW might be debated. In this case, due to differences in voltage, one must apply solutions including EPI with galvanic isolation. Such EPI, regardless of its realization, is termed Solid State Transformer (SST).

Figure 20 demonstrates different approaches to realization of a SST [56], where each SST consists of the following converters: 1) MV AC-DC + MV/LV DC-DC + LV DC-AC; 2) MV/LV AC-DC + LV DC-AC; 3) MV AC-DC + MV/LV DC/AC; 4) MV/LV AC-AC. Realization of 2 is advantageous when unidirectional power flow is sufficient and requirements are not very high, and when only lower power is concerned. In other cases, in particular if required bidirectional power flow, realization 1 is favorable. This realization of SST is the most flexible and can fulfill additional functions such as improvement of input or output power quality or attachment of storage and renewable source in LV DC-bus. At the same time, realization 4 with current power electronics technology (for example [57]) is not efficient and nothing seems to indicate changes in the near future [58]. It appears that after application of HF-transformer this realization would be concurrent to realization 1 with transformer HF (Fig. 21). However, even disregarding characteristics of PE switching, SST without DC-link cannot smooth pulsation without instantaneous active power. In consequence, SST without DC-link can improve power quality only within the range of compensation of instantaneous reactive power. Moreover, realization of 4 SST requires application of significantly larger input and output filters than in the case of realization 1. Taking into consideration flexibility and multi-functionality, the name PE Smart Transformer (PE-ST) should be used only for SST with configuration illustrated in Fig. 21.2 [59, 60].

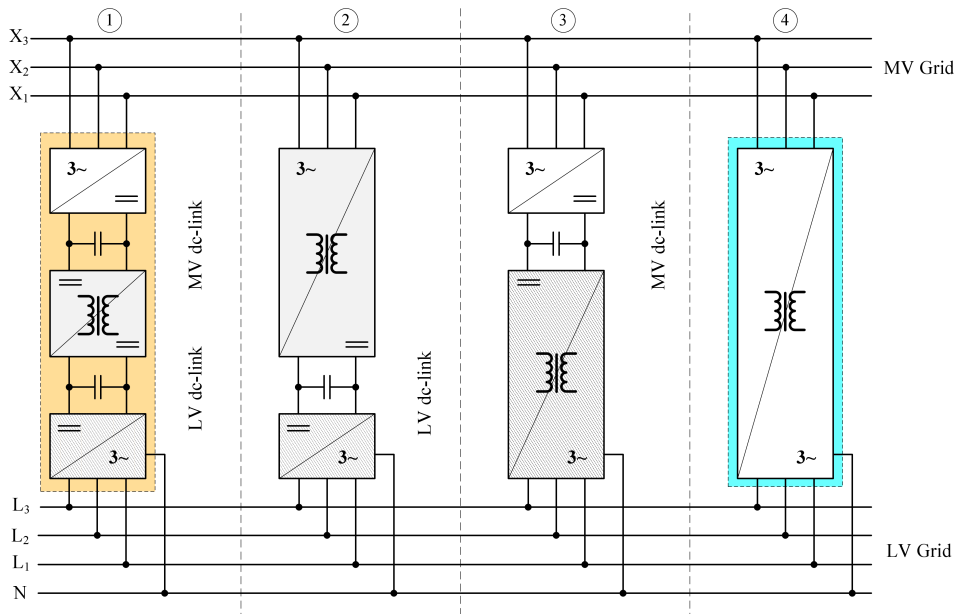

Fig. 20. Different approaches to realize a SST: 1) three stage power conversion with MV and LV DC-link; 2) two stage power conversion with LV DC-link only; 3) two stage power conversion with MV DC-link only; 4) direct AC-AC converter without any DC-link

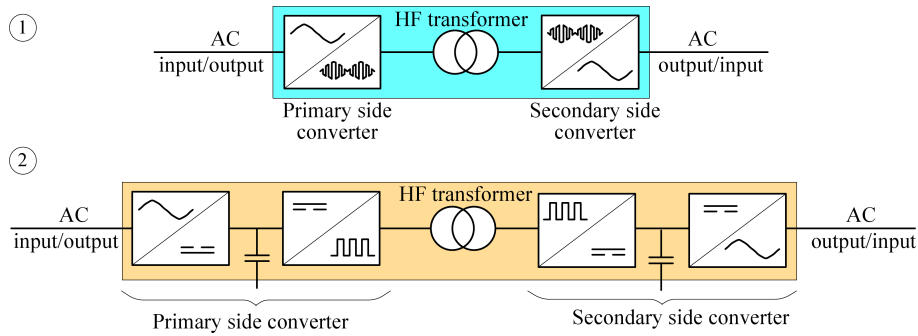

Fig. 21. Two basic configuration of the bidirectional SST with HF transformer: 1) without DC-link, 2) with DC-link

Figures 22 and 23 illustrate the idea of PE-ST arrangements. In the presented PE-ST in Fig. 22 [61], each phase consists of M identical AC-DC-AC-Tr-AC-DC-AC converter cells, series connected on the side of the higher voltage, and in parallel, on the side of the lower. There are also possible other cell connections, by which it is always necessary to ensure equal loading and equal voltages. However, the advanced typology of the PE-ST construction results in higher

pulsations of instantaneous power in DC-buses of the primary and secondary side converters. This requires application of capacitors with greatest capacitance in DC-links. This disadvantage is not present in PE-ST depicted in Fig. 23. In the PE-ST 3-phase modules are connected, which in case of supply symmetry and reception prevents unnecessary pulsations of instantaneous power in DC-buses.

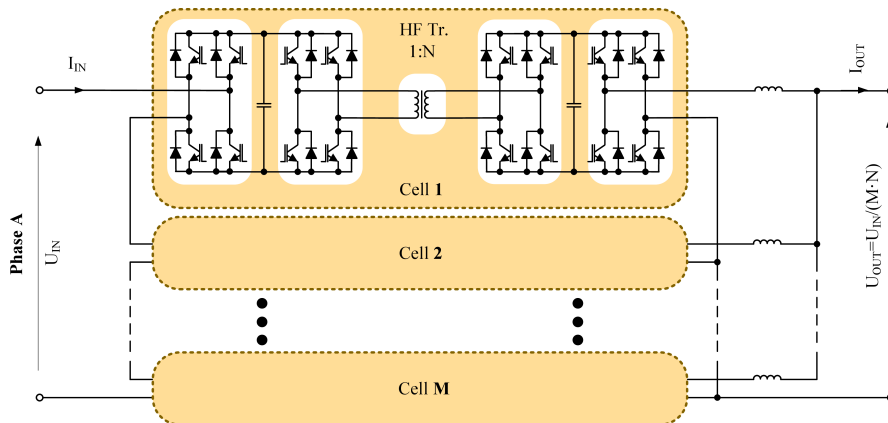

Fig. 22. Example scheme of one phase in the MV/LV PE-ST system with separated phases

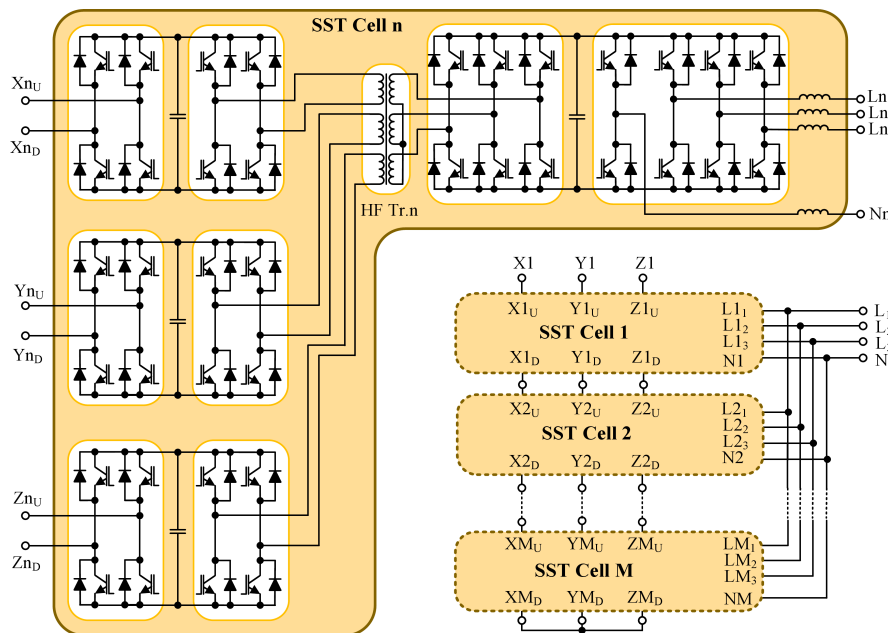

Fig. 23. Example scheme of a modular three-phase MV/LV PE-ST

It is estimated that high power and medium voltage PE-ST, ensuring the same functional capabilities as typical “back-to-back” couplers, will be about one third the size of conventional transformers (Fig. 24) [61].

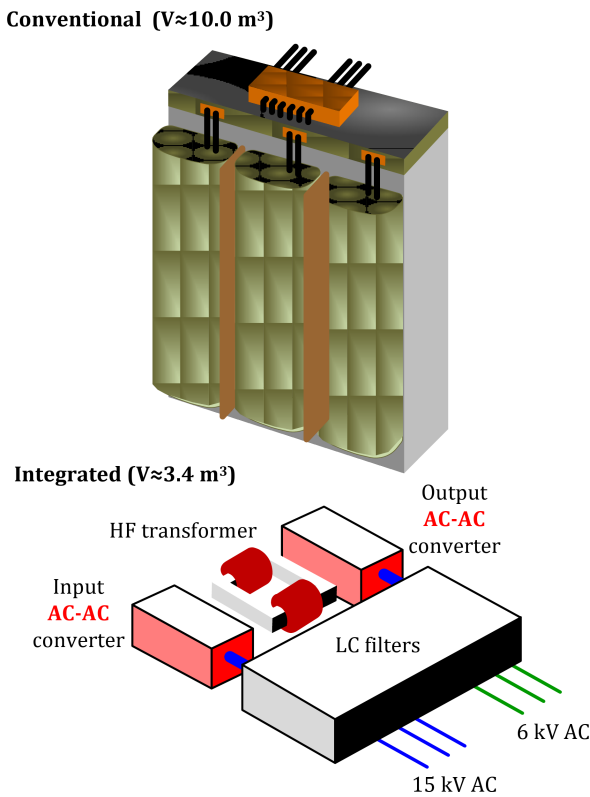

Fig. 24. Construction and comparison of conventional transformer and PE-ST arrangement body dimensions

6. Vehicle to grid (V2G) and vehicle to home (V2H) technology – the first cell in the smart electrical power system (EPS)

6.1. The need, objectives and benefits. The process of greenhouse gas emission reduction and price vacillation of fossil fuels caused by the exhaustion of easily accessible resources initiated the development of the idea of constructing Electric Vehicles (EV) [62]. Although the situation of manufacturers of cars with combustion engines continues to look unthreatened, many of them have begun work or have already put on sale cars fitted with electric motors. A very important point in the case of such vehicles is the range, which at the present moment is estimated to be about 100-150 km. The range is limited by the size and construction of the batteries powering the motor, but to a significant degree also the lack of infrastructure for their fast charging.

At the present moment there are projects being realised connected with the development of a system of charging terminals for electric vehicles, in which respect one is forced to ask whether the distribution system of electrical energy is prepared for the scenario of a boom in electrical transport,

since at this moment there has been a lack of reserve power [63, 64].

Figure 25 presents the daily demands on the EPS in respect of the additional load from charging terminals for electric vehicles. The majority of currently produced EVs are equipped with a storage system of about 20 kWh, which on the assumption of a 10-hour charging cycle means loading the EPS with a power of about 2 kW over a 10-hour period. With a number of 1000 electrical cars this means an extra 2 MW load and this is insignificant for an electrical power system. Let us imagine, however, a scenario of rapid entry to electrical transport, that is, e.g., a growth in number of EVs to 1 M units. In such a case the EPS would be loaded by an additional 2 GW of power. We may, however, reverse the situation and ask whether the infrastructure for charging EVs could be used to improve the stability of the power grid.

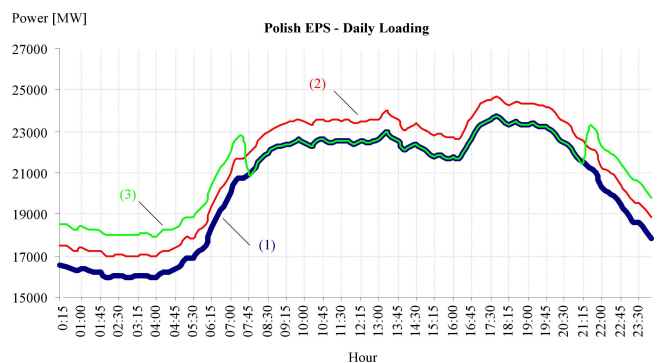

Fig. 25. Daily loading of electrical power system in the winter period taking into account terminals for charging of electric vehicles

Curves of the daily loading on the Polish EPS: ignoring the additional power for charging EVs, curve (1), are visible in Fig. 25; taking into account this power throughout the day with a coincidence factor of 0.5, curve (2); and with charging power restricted by time through an EPS operator within the hours, e.g., 21:30 to 7:30 it shows that by introducing certain procedures by EPS operator, in grids with V2G or V2H technology it would allow a balancing of the daily load curve [65–71]. Additionally, a systematic solution in the form of differential tariff calculations for consumed or uploaded energy in relation to the time of day might lead to both V2G and V2H technologies becoming additional instruments in the hands of the EPS operator, instruments leading to an increase in the reliability of the power system, mainly at the level of low voltage grids. In principle it seems equally effective for the purpose of exploiting the infrastructure for charging EVs as elements of local market balancing energy generated in small local renewable energy sources with energy from the grid (Fig. 26). This would allow the transfer of a large part of the investment in the extension of the EPS and the related development of electrical transport to the level of low voltage and it would give time for the setting up of new power generation units.

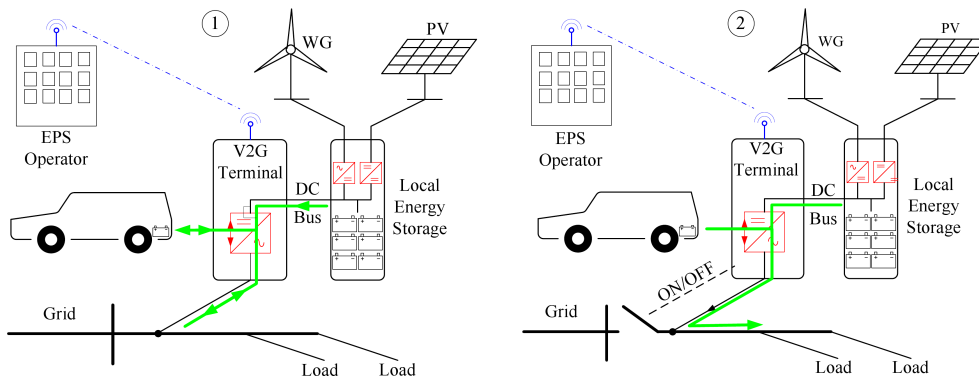

Fig. 26. Exploitation of V2G technology in low-volt grids: 1) reactive and distortion power compensation, 2) back-up power

Both technologies, equally V2G and V2H are based on bidirectional flows of energy, which is possible to achieve only with the use of bidirectional power electronics converter. The first of these is directed above all to the Ancillary Services related to improvement of the power profile of the grid at the point of connection effected through a change in the flow of current components. For the proper operation of the converters fulfilling these functions there is required, however, a continuity of voltage at the network connections. V2H technology is free of this limitation and has the possibility to enter voltage mode of operation as well as fulfilling back-up power function. However, on account of safety factors the technology is “held back” in the network hierarchy to the depth of electrical installation of end-users and requires appropriate separation of the installation (Fig. 27).

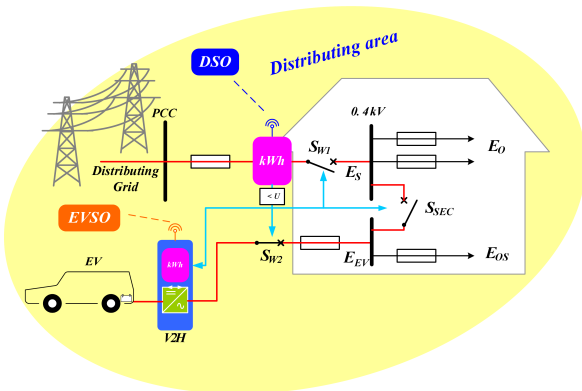

Fig. 27. EV charging terminal in V2H technology, (DSO – Distributing System Operator)

For change of mode of operation of the converter (from current to voltage) the loss of grid voltage is used as a signal, indication of which is derived, e.g., from an intelligent measuring system. V2G technology (Fig. 28) does not require invasion of the end-user’s electrical installation, while proper functioning does require information on the state of the grid at the place of connection, e.g., with external metering of the grid parameters – GPM (Grid Parameters Metering). Thanks to the use of an intelligent subscriber measuring system in V2H terminal it is possible to see evidence of services similar to V2G within the range of reactive and distortion power compensation, though they are limited to the client’s inter-

nal installation. In this device the information concerning the services provided need not be sent to EVSO (Electric Vehicle System Operator), since the services are a matter for the end-user and are shown in the end-user’s measuring device.

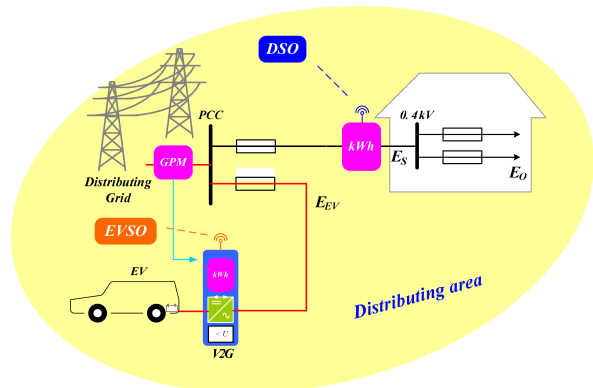

Fig. 28. EV charging terminal in V2G technology, (DSO – Distributing System Operator)

For change of mode of operation of the converter (from current to voltage) the loss of grid voltage is used as a signal, indication of which is derived, e.g., from an intelligent measuring system. V2G technology (Fig. 28) does not require invasion of the end-user’s electrical installation, while proper functioning does require information on the state of the grid at the place of connection, e.g., with external metering of the grid parameters – GPM (Grid Parameters Metering). Thanks to the use of an intelligent subscriber measuring system in V2H terminal it is possible to see evidence of services similar to V2G in the range of reactive and distortion power compensation, though they are limited to the client’s internal installation. In this device the information concerning the services provided need not be sent to EVSO (Electric Vehicle System Operator), since the services are a matter for the end-user and are shown in the end-user’s measuring device.

From the point of view, however, of the possible excise duty on active energy used or given back for the needs of charging electric vehicles it is not possible to resign in V2H terminals from a separate measuring device, although it is possible to limit its functionality to the measurement and transmission of data on the topic of active energy.

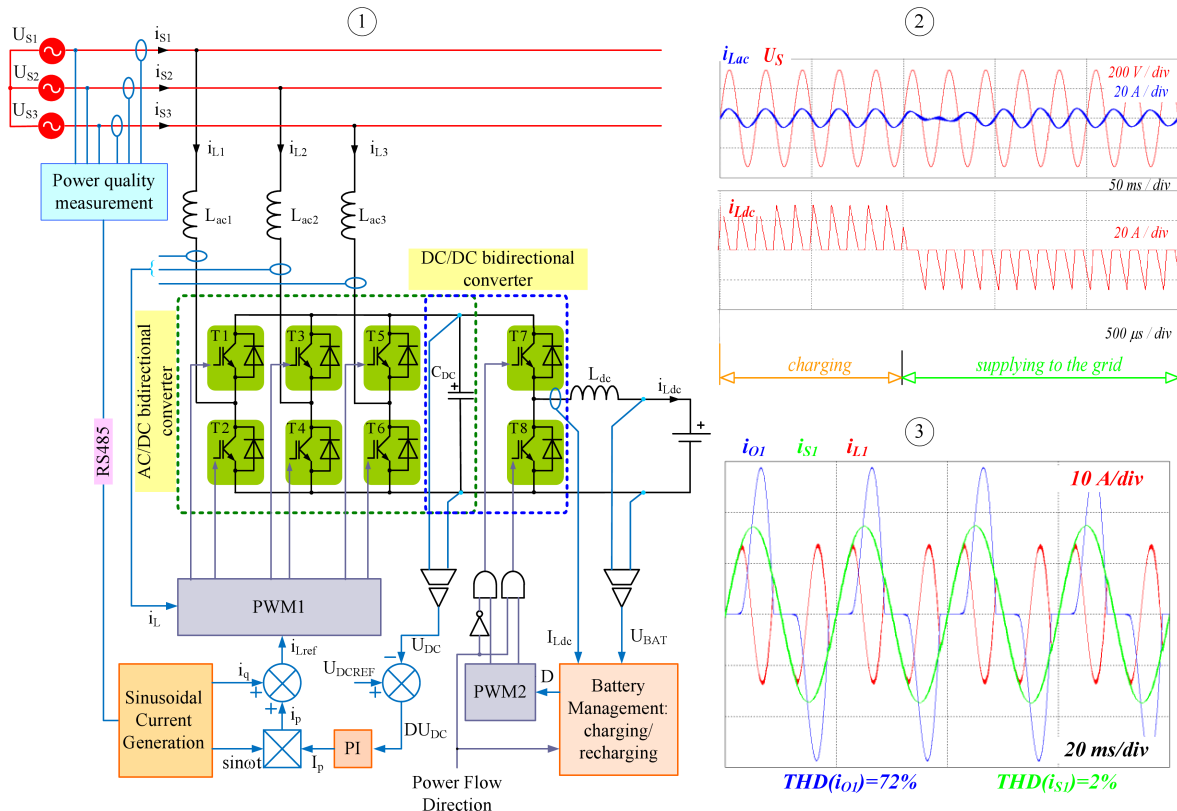

Fig. 29. Converter with bidirectional energy flow for cooperation with electric vehicles in fast charging mode: 1) device diagram; 2) time flow during change of direction of energy transmission; 3) in Ancillary Service mode of operation (distortion power compensation)

6.2. PE arrangements used in EV charging terminals. Terminals converter built according to the universal structure in Fig. 29.1 may be equally realized with basic functions connected with energy transmission from the distribution system to electric vehicle energy resources, sent in the opposite direction or with additional functions related to Ancillary Services [69]. A change of direction in the energy flow is forced by entry of a bidirectional DC/DC converter into the reverse mode of operation. In this mode there occurs a permanent switching off of transistor T7 and beginning of work in the boost mode with the help of transistor T8. A change in the quantity of energy returned to the public grid is obtained by a change in the duty cycle D coefficient of the PWM2 modulator output signal controlling the work of the transistor.

In both modes of operation the AC/DC bidirectional converter fulfils the role of a dependent device which forces the drawing or returning of energy from or to the grid. This takes place through forming phase currents $i_{L1}-i_{L3}$ in such a way that these currents are in phase or out of phase with the phase voltage of the supply network Fig. 29.2.

For the purpose of delivering Ancillary Services for the EPS, such as reactive power compensation, compensation of current distortions Fig. 29.3, the control device must possess essential information in respect to energy quality parameters at the location of the connection. Such information can derive from, e.g., GPM or power quality analyzers. An additional

component of the current converter i_q , calculated on the basis of energy parameters received, is then added to the reference signal of the PWM1 current modulator.

Work in Ancillary Service mode (e.g., reactive power compensation, distortion power compensation) does not always require the presence of energy resources, therefore, not all services require authorization from the side of the user of the terminal, and may be switched on remotely by the EV System Operator.

The development of fast charging technology may also lead to the development of V2G and V2H technologies exploiting electric vehicles as mobile energy resources. Although in the near future there is little hope of connecting these technologies in the field of global stabilization of Electrical Power Systems, the elements of these technologies may give local benefits, especially for informed end-users investing in fast charging terminals. Equipping them with additional functions, allowing for measurable benefits resulting from the regulation of one's own consumption profile, especially in multi-sector systems, may lead to rapid return of investment costs, and in so doing lead to greater popularity of such systems.

7. Conclusions

Power-electronic technology as part of a Smart Grid infrastructure enables a fuller exploitation of existing distrib-

utional resources in the EEN, maintaining and even improving the hitherto state of the power supply security and quality of EE. Of vital significance in this is the effectiveness and response speed of modern PE arrangements, permitting smooth and dynamic regulation of lagging parameters due to load changes and power network configurations. Equally important is the fact that such PE converters can usually fulfill many different functions connected with conditioning of the EE. This all means that power-electronic technology, oriented towards EEN, leads significantly over traditional technologies. Only PE technologies create the right foundation for the development of power regulating units, securing the efficient realization and the use of Smart Grids potential [40].

The material presented does not exhaust the very extensive application possibilities for PE in Smart Grids. Because of the limited length, the theoretical discussion has been completely omitted, in particular the part concerning the control of PE arrangement, as well as considerations with respect to many important solutions and conceptions of devices and systems. For the majority of such discussions familiarity with the cited literature will suffice. Nevertheless, the authors hope that this article will inspire the search for new effective solutions within the area discussed, original in their conception and economically far-reaching. This has particular significance in relation to European Union directives in the matter of efficient use of energy. In this context it can be expected that along with development of small local power industries and the fulfillment of distributed power supply concepts, power-electronic devices fulfilling various functions will constitute standard equipment in modern Electrical Energy Network.

REFERENCES

- [1] B. Sørensen, *Renewable Energy. Volume I: Renewable Energy Origins and Flows. Volume II: Renewable Energy Technologies I, Volume III: Renewable Energy Technologies II, Volume IV: Renewable Energy in Society*, Earthscan, Cambridge, 2011.
- [2] G. Benysek, *Improvement in the Quality of Delivery of Electrical Energy Using Power Electronics Systems*, Springer-Verlag, London, 2007.
- [3] R. Strzelecki and G. Benysek, *Power Electronics in Smart Electrical Energy Networks*, Springer-Verlag, London, 2008.
- [4] C. Gellings, "Smart power delivery: a vision for the future", *EPRI J.* 1, CD-ROM (2003).
- [5] J. Wang, A.Q. Huang, W. Sung, Y. Liu, and B.J. Baliga, "Smart grid technologies", *IEEE Indust. Electronics Magazine* 3 (2), 16–23 (2009).
- [6] J. Machowski, "Flexible transmission systems – FACTS", *Electrotechnical Review* 78 (7), 189–196 (2002), (in Polish).
- [7] V.K. Sood, *HVDC and FACTS Controllers: Applications of Static Converters in Power Systems*, Springer-Verlag, London, 2004.
- [8] F. Blaabjerg and Z. Chen, *Power Electronics for Modern Wind Turbines*, Morgan & Claypool, San Rafael, 2006.
- [9] L. Wang, Ch. Singh, and A. Kusiak, *Wind Power Systems. Applications of Computational Intelligence*, Springer-Verlag, London, 2010.
- [10] S. Heier and R. Waddington, *Grid Integration of Wind Energy Conversion Systems*, Wiley, Blackwell, 2006.
- [11] M.G. Simões, *Renewable Energy Systems. Design and Analysis with Induction Generators*, CRC Press, London, 2004.
- [12] I. Boldea, *Variable Speed Generators*, Taylor & Francis Group, London, 2006.
- [13] A. Sikorski and A. Kuźma, "Cooperation of induction squirrel-cage generator with grid connected AC/DC/AC converter", *Bull. Pol. Ac.: Tech.* 57 (4), 317–322 (2009).
- [14] D. Schulz, "Improved grid integration of wind energy systems", *Bull. Pol. Ac.: Tech.* 57 (4), 311–315 (2009).
- [15] I. Wasiak and Z. Hanzelka, "Integration of distributed energy sources with electrical power grid", *Bull. Pol. Ac.: Tech.* 57 (4), 297–309 (2009).
- [16] M.P. Kazmierkowski, R. Krishnan, and F. Blaabjerg, *Control in Power Electronics*, Academic Press, London, 2002.
- [17] M. Bobrowska-Rafał, K. Rafał, G. Abad, and M. Jasiński, "Control of PWM rectifier under grid voltage dips", *Bull. Pol. Ac.: Tech.* 57 (4), 337–343 (2009).
- [18] B.K. Bose, *Power Electronics and Motor Drives: Advances and Trends*, Academic Press, London, 2006.
- [19] N.P. Quang, *Vector Control of Three-Phase AC Machines: System Development in the Practice*, Springer-Verlag, London, 2008.
- [20] A. Emadi, A. Nasiri, and S.B. Bekiarov, *Uninterruptible Power Supplies and Active Filters*, CRC Press, London, 2005.
- [21] I. Hadjipaschalis, A. Poullikkas, and V. Efthimiou, "Overview of current and future energy storage technologies for electric power applications", *Renewable and Sustainable Energy Reviews* 13 (6–7), 1513–1522 (2009).
- [22] C. Sourkounis, B. Ni, and F. Richter, "Comparison of energy storage management methods to smooth power fluctuations of wind parks", *Electrotechnical Review* 85 (10), 196–200 (2009), (in Polish).
- [23] F. Blaabjerg, Z. Chen, and S.B. Kjaer, "Power electronics as efficiency interface in dispersed power generation systems", *IEEE Trans. on Power Electronics* 19 (5), 1184–1194 (2004).
- [24] Y. Jiang and J. Pan "Single phase full bridge inverter with coupled filter inductors and voltage doubler for PV module integrated converter system", *Bull. Pol. Ac.: Tech.* 57 (4), 355–361 (2009).
- [25] J.P. Dunlop, *Photovoltaic Systems*, American Technical Publication, New York, 2009.
- [26] P. Enjeti, L. Palma, and M.H. Todorovic, *Power Conditioning Systems for Fuel Cell Applications*, John Wiley & Sons, London, 2009.
- [27] J. Lai, "Power conditioning circuit topologies", *IEEE Ind. Electronics Magazine* 3 (2), 24–34 (2009).
- [28] F.L. Luo, *Essential DC/DC Converters*, CRC Press, London, 2006.
- [29] S. Jalbrzykowski and T. Citko, "A bidirectional DC-DC converter for renewable energy systems", *Bull. Pol. Ac.: Tech.* 57 (4), 363–368 (2009).
- [30] M. Calais, J. Myrzik, T. Spooner, and V.G. Agelidis, "Inverters for single-phase grid connected photovoltaic systems – an overview", *Conf. Proc. PESC* 4, 23–27 (2000).
- [31] Y. Huang, M. Shen, F.Z. Peng, and J. Wang, "Z-Source inverter for residential photovoltaic systems", *IEEE Trans. on Power Electronics* 21 (6), 176–182 (2006).
- [32] M.K. Kazimierczuk, *High Frequency Magnetics Components*, John Wiley & Sons, London, 2009.
- [33] A. Emadi, *Integrated Power Electronic Converters and Digital Control*, CRC Press, London, 2009.

- [34] W. Liu, J. Dirker, and J.D. van Wyk, "Power density improvement in integrated electromagnetic passive modules with embedded heat extractors", *IEEE Trans. on Power Electronics* 23 (6), 3142–3150 (2008).
- [35] R. Lasseter and P. Paigi, "Microgrid: a conceptual solution", *Conf. Proc. PESC* 6, 4285–4290 (2004).
- [36] T. Ise, "Advantages and circuit configuration of a DC microgrid", *Proc. Symposium on Microgrids* 1, CD-ROM (2006).
- [37] A. Kawamura, M. Pavlovsky, and Y. Tsuruta, "State-of-the-art. High power density and high efficiency DC-DC chopper circuits for HEV and FCEV applications", *Electrotechnical Review* 84 (9), 1–13 (2008).
- [38] A. Ghosh and G. Ledwich, *Power Quality Enhancement Using Custom Power Devices*, Kluwer Academic Pub., New York, 2002.
- [39] G. Benysek, "Improvement in the efficiency of the distributed power systems", *Bull. Pol. Ac.: Tech.* 57 (4), 369–374 (2009).
- [40] A. Carlsson, *The Back to Back Converter – Control and Design*, Lund Institute of Technology, Lund, 1998.
- [41] B.M. Han, S.T. Baek, B.Y. Bae, and J.Y. Choi, "Back to back HVDC system using a 36-step voltage source converter", *IEEE Proc. Generation, Transmission and Distribution* 153 (6), 677–683 (2006).
- [42] N. Flourentzou, V.G. Agelidis, and G.D. Demetriades, "VSC based HVDC power transmission systems: an overview", *IEEE Trans. on Power Electronics* 24 (3), 592–602 (2009).
- [43] G. Błajszczak, M. Wasiluk-Hassa, M. Malinowski, M.P. Kaźmierkowski, and M. Jasiński, "The state of the art of HVDC transmission systems", *Electrical Power Engineering* 7 (1), CD-ROM (2011).
- [44] M. Hagiwara, H. Fujita, and H. Akagi, "Performance of a self-commutated BTB HVDC link system under a single-line to ground fault condition", *IEEE Trans. on Power Electronics* 18 (1), 278–285 (2003).
- [45] J. Rodriguez, J.S. Lai, and F.Z. Peng, "Multilevel inverters: a survey of topologies, controls, and applications", *IEEE Trans. on Electronics* 49 (4), 724–738 (2002).
- [46] B. Wu, *High-Power Converters and AC Drives*, John Wiley & Sons, London, 2006.
- [47] M. Hagiwara, K. Wada, H. Fujita, and H. Akagi, "Dynamic behavior of a 21 level BTB based power flow controller under single-line-to-ground fault conditions", *IEEE Trans. on Indust. Applications* 43 (5), 1379–1387 (2007).
- [48] Z. Jiang and H. Yu, "Hybrid DC and AC linked microgrids: towards integration of distributed energy resources", *IEEE Energy 2030 Conf.* 1, 1–8 (2008).
- [49] H. Akagi, E.H. Watanabe, and M. Aredes, *Instantaneous Power Theory and Applications to Power Conditioning*, John Wiley & Sons, London, 2007.
- [50] H. Fujita and H. Akagi, "Unified power quality conditioner: the integration of series and shunt active filter", *IEEE Trans. on Power Electronics* 13 (2), 315–322 (1998).
- [51] M. Aredes, K. Heumann, and E. Watanabe, "An universal active power line conditioner", *IEEE Trans. on Power Delivery* 13 (2), 1453–1460 (1998).
- [52] J. Wang and F.Z. Peng, "Unified power flow controller using the cascade multilevel inverter", *IEEE Trans. on Power Electronics* 19 (4), 1077–1084 (2004).
- [53] T. Jauch, A. Kara, M. Rahmani, and D. Westermann, *Power Quality Ensured by Dynamic Voltage Correction*, ABB Rev., New York, 1998.
- [54] C.J. Huang, S.J. Huang, and F.S. Pai, "Design of dynamic voltage restorer with disturbance-filtering enhancement", *IEEE Trans. Power Electronics* 18 (5), 1202–1210 (2003).
- [55] E.R. Ronan, S.D. Sudhoff, S.F. Glover, and D.L. Galloway, "A power electronic-based distribution transformer", *IEEE Trans. on Power Delivery* 17 (2), 537–543 (2002).
- [56] L. Heinemann and G. Mauthe, "The universal power electronics based distribution transformer, an unified approach", *Power Electronics Specialists Conf. – PESC* 2, 504–509 (2001).
- [57] D.D. Chen, "Novel current-mode AC/AC converters with high-frequency AC link", *IEEE Trans. on Indust. Electronics* 55 (1), 30–37 (2008).
- [58] T. Friedli and J.W. Kolar, "Comprehensive comparison of three-phase AC-AC matrix converter and voltage DC-Link back-to-back converter systems", *Proc. IEEE/IEEJ Int. Power Electronics Conf.* 1, 1–10 (2010).
- [59] S. Inoue and H. Akagi, "A bi-directional isolated DC-DC converter as a core circuit of the next-generation medium-voltage power conversion system", *Power Electronics Specialists Conf. PESC* 48, 314–320 (2006).
- [60] V. Staudt, A. Steimel, and H. Wrede, "Konzept eines mobilen elektronischen 110-kV/mittelspannungs-leistungs-transformators", *Technische Innovationen in Verteilungsnetzen: Vorträge der ETG-Fachtagung* 1–2, 59–66 (2005).
- [61] J.J. Wang, A.Q. Huang, S. Woongje, Y. Liu, and B.J. Baliga, "Smart grid technologies. development of 15-kV SiC IGBTs and their impact on utility applications", *IEEE Indust. Electronics Magazine* 1, 6 (2009).
- [62] Directorate-General for Energy and Transport, *Eur. Energy and Transport Trends to 2030*, European Commission, Brussels, 2007.
- [63] K. Clement-Nyns, E. Haesen and J. Driesen, "The impact of vehicle-to-grid on the distribution grid", *Electric Power Systems Research* 81 (1), 185–192 (2011).
- [64] H. Lund and W. Kempton, "Integration of renewable energy into the transport and electricity sectors through V2G", *Energy Policy* 36 (9), 3578–3587 (2008).
- [65] W. Kempton and J. Tomić, "Vehicle-to-grid power fundamentals: calculating capacity and net revenue", *J. Power Sources* 144 (1), 268–279 (2005).
- [66] Ch. Guille and G. Gross, "A conceptual framework for the vehicle-to-grid (V2G) implementation", *Energy Policy* 37 (11), 4379–4390 (2009).
- [67] G. Mulder, F. De Ridder, and D. Six, "Electricity storage for grid-connected household dwellings with PV panels", *Solar Energy* 84 (7), 1284–1293 (2010).
- [68] D. Paramashivan Kaundinya, P. Balachandra, and N.H. Ravindranath, "Grid-connected versus stand-alone energy systems for decentralized power – a review of literature", *Renewable and Sustainable Energy Reviews* 13 (8), 2041–2050 (2009).
- [69] R. Miśkiewicz, A. Moradewicz, and M.P. Kaźmierkowski, "Contactless power supply system with bidirectional energy transfer for electric vehicle", *Electrotechnical Review*, 8, 212–218 (2011), (in Polish).
- [70] Y. Hanh, M. Khan, L. Xu, G. Yao, L. Zhou, and C. Chen, "A new scheme for power factor correction and active filtering for six-pulse converters loads", *Bull. Pol. Ac.: Tech.* 57 (2), 157–169 (2009).
- [71] W. Jing-Xin and J. Jian-Guo, "Combining the principles of variable structure, direct torque control, and space vector modulation for induction motor fed by matrix converter", *Bull. Pol. Ac.: Tech.* 58 (4), 657–663 (2010).