

PROPULSION AND MANEUVERING SYSTEMS' CHARACTERISTICS OF THE U.S. FLAGGED GREAT LAKES SELF-UNLOADING BULK CARRIERS

Mariusz Przybylski

Gdansk University of Technology
ul. Narutowicza 11/12, 80-950 Gdansk, Poland
email: mariusz.przybylski@pg.edu.pl

Abstract

Paper contains an overview of the propulsion and maneuvering systems' characteristics of United States flagged Great Lakes self - unloading bulk carriers. A contrast between the importance of the transport task carried by those vessels to their low number and considerable age suggests the need to review and understand their complexity as well as complexity of their operations in order to provide suitable energy- and operational efficiency upgrades. Such review can prove to be challenging due to limited information available in the literature. Environment in which those vessels operate and their operational profile have been also reviewed due to the fact that they gave rise to the unique hull - form that subsequently influenced the propulsion and maneuvering system design in a significant manner. The environment and operational profile were also found to influence propulsion and maneuvering systems' form more directly: through the requirements posed on vessels maneuvering capabilities and propulsive power requirements.

Keywords: vessel propulsion, vessel maneuvering, bulk carrier, Great Lakes bulk carrier, self-unloader

1. Introduction

Great Lakes - St. Lawrence Seaway System plays a vital role as a major transportation corridor within the area of Great Lakes and St. Lawrence River basins. Three primary cargoes transported by ships on Great Lakes are iron ore, limestone and coal [2], [3]. According to [1] every year more than 160 million metric tons of cargo are moved on the Great Lakes - St. Lawrence Seaway System. More recent study results, described in [3], show that in 2017 the cargo moved on the Great Lakes-St. Lawrence Seaway System totaled to about 143.5 million metric tons. Such volume is deemed impossible to be transferred to the land-based transportation system without severe economic implications for the industries served, [2]. Above mentioned transportation task is carried by Canadian and U.S. flagged vessels. However, Section 27 of the Merchant Marine Act, known as the Jones Act, allows only U.S. flagged vessels to be employed in cabotage, [3]. That being the case all transport between U.S. ports (e.g. supply of raw materials to steel mills or coal to power plants) has to be carried by U.S. flagged vessels.

The importance of this means of transport to the regional economics is in vast contrast to the fleet that carries the task. According to [4] in 2011 there were 56 U.S. flagged vessels (self-propelled and tug/barge assemblies) of 1000 Gross Tons (GT) and more operating on Great Lakes. Those vessels are also known and referred to as lakers or lake freighters. If to compare the number of lakers to the total number of vessels employed in U.S. coastwise trade one will notice that lakers amount to approximately 0.15% of the total. Furthermore majority of those vessels were built before 1987, what means that they are currently over 30 years old, [4]. Lack of new U.S. flagged vessels on the Great Lakes can likely be, at least partially, attributed again to the Jones Act which requires all waterborne transportation between two ports in the United States to be taken aboard a vessel that is U.S. built, U.S. owned, U.S. flagged, and U.S. crewed, [3]. As such the Jones Act prohibits ordering and building lakers in low-cost far-east shipyards. That, combined with relatively low rates, [5], results in lack of U.S. flagged new-builds. Such situation puts an emphasis on improving energy-

and operational efficiency of existing vessels. In this spirit, in order to decrease the cargo unloading times, currently operating vessels employed in bulk cargo transport are equipped with self-unloading gear in form of belt conveyors. Such U.S. flagged vessels are object of interest within this work and will be later referred to as self-unloaders.

2. Operational Environment

Great Lakes self-unloaders operate on North American Great Lakes - a part of Great Lakes - St. Lawrence Seaway System (which includes the five Great Lakes: Lake Superior, Lake Michigan, Lake Huron, Lake Erie and Lake Ontario, their connecting rivers, and the St. Lawrence Seaway (ending in Montreal), [6]).

There, in general, is a west - east water flow direction in which Lake Superior (at 183.4m above sea level, [2]) drains into Lake Huron via the St. Mary's River, Lake Huron drains into Lake Erie via the St. Clair and Detroit River and Lake Erie drains into Lake Ontario via the Niagara River. The entire system flows to the Atlantic Ocean via the St. Lawrence River, [7].

Due to a smaller water depth and fetch length maximum sea states observed on the Great Lakes are generally less than the ones observed on the open ocean, [8].

Considering that the usual sailing speed of a large twin-screw lake bulk-carrier sailing in loaded condition (8.6m draught) through the lake would be approximately equal to 12.4kn, [9], one can calculate water-depth-based Froude number for each of Table 1 entries as:

$$Fn_h = \frac{v}{\sqrt{gh}}, \quad (1)$$

where:

v [ms^{-1}] – vessel speed,

g [ms^{-2}] – module of standard acceleration due to gravity,

h [m] – water depth.

Table 1 Average depth of five Great Lakes [2]

Lake [-]	Erie	Huron	Michigan	Ontario	Superior
Average Depth [m]	19	59	85	86	147
Water depth/Vessel draught [-]	2.21	6.86	9.88	10.00	17.09
Fn_h [-]	0.47	0.27	0.22	0.22	0.17

Inspecting the data in Table 1 and comparing the Fn_h values with criterion proposed in [10], one can judge that only in case of Lake Erie the shallow-water effects on vessels resistance, while in lake transit, can be noticeable. That would mean that the lake transit in majority of cases reassembles deep water/open sea conditions, with a difference with regards to wave climate.

However, as mentioned before, Great Lakes are connected with each other by rivers that carry the chain of drainage from Lake Superior all the way to the Atlantic Ocean. This drainage occurs due to elevation difference. Because of extensive elevation difference between certain lakes dangerous rapids have been present, what combined with falls, restricted water depths and river widths made large scale commercial navigation challenging. That was the reason why a series of U.S. and Canadian lock systems and channels were built.

Major such objects are:

- Soo Locks: consisting of four parallel locks and located in Sault Ste. Marie on St. Mary's River (that connects Lake Superior and Lake Huron). Currently only two largest locks serve commercial navigation, [2], [7], and are used by vessels transiting between Lake Superior, Huron and Michigan, [8]:
 - Poe Lock that is 365.76m long, 33.53m wide, 9.75m deep and can accommodate vessels up to 309.07m in length and 32.00m in beam (that is including the largest vessels on the Great Lakes, the "1000-footers"),
 - MacArthur Lock that is 243.84m long, 24.38m wide, 8.99m deep and can accommodate vessels of the "Seaway Max" (Seaway Max class means the maximum vessel size allowed in the St Lawrence Seaway, [11]) which are which 225.55m long and have a beam of 23.77m.

The draught restriction on the locks is 8.382m (27.5ft), [5]. On top of those restrictions, the connecting channels in the St. Mary's River have a navigable draught of 8.08m at mean low water datum, [8].

- The Welland Canal: a part of St. Lawrence Seaway, enables safe navigation between Lake Erie and Lake Ontario by bypassing Niagara Falls (elevation difference of 99.3m). It incorporates eight locks, each 233.5m long, 24.4m wide and 9.1m deep able to accommodate the Seaway Max size vessels [2], [7].
- St. Lawrence Seaway – Montreal/Lake Ontario Section: features seven locks and connects Lake Ontario and Montreal. This locks lift or lower the ships by 74.1m and are able to accommodate vessels up to Seaway Max size, [7].

Due to exclusively fresh water operation Great Lakes vessels are far less affected by the corrosion than their ocean-going counterparts. As a consequence the life-span of those vessels is very long and there are examples of vessels operated for 100 years or even longer (e.g. E. M. Ford built in 1898 and operated for 100 years [8], or cement carrier St. Mary's Challenger launched in 1906 and still in operation [12]).

3. Hull Form

Due to generally shorter distances between ports than in case of ocean shipping vessel's cargo-carrying capacity and unloading rate was found to be more important than the vessel's speed. That, along with operation in locks, resulted in very full forms (forms with high block coefficient values), [8], [5].

In [13] authors present data from selected 50 model tank tests of Great Lakes bulk carriers built over 30-year period prior to 1972, deemed to form a representative sample.

Figure 1 presents the block coefficient (C_B) distribution in the selected population. Analysis of the plot confirms the above statement with regards to high block coefficient values as the majority of hulls were clustered in the range between 0.84 - 0.90.

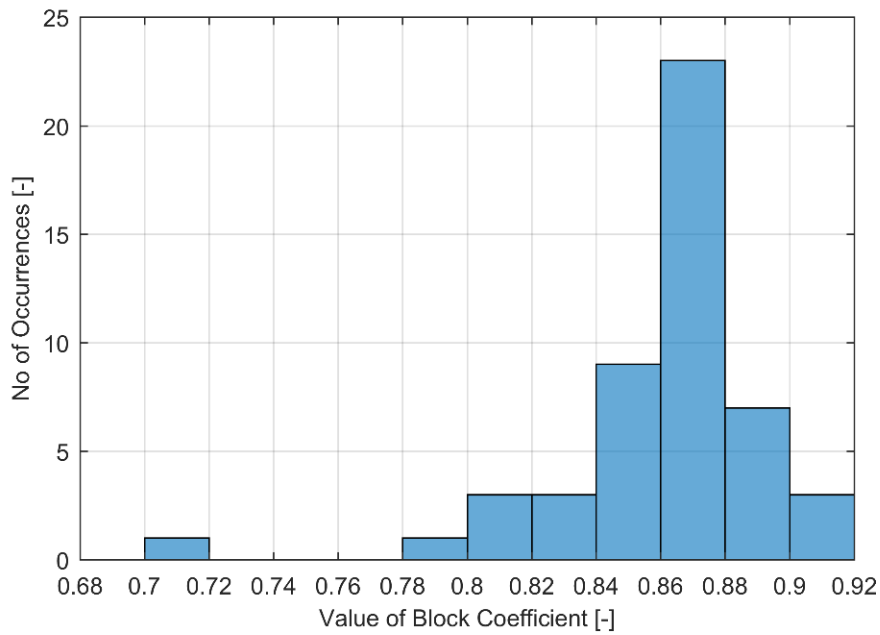

Figure 1 Distribution of block coefficient in Great Lakes bulk carriers. Based on data in [13]

Figure 2 presents the distribution of length to beam ratio (L/B). It is apparent that the hulls are characterized by very large L/B ratio with majority of them in the range between 9 - 10.

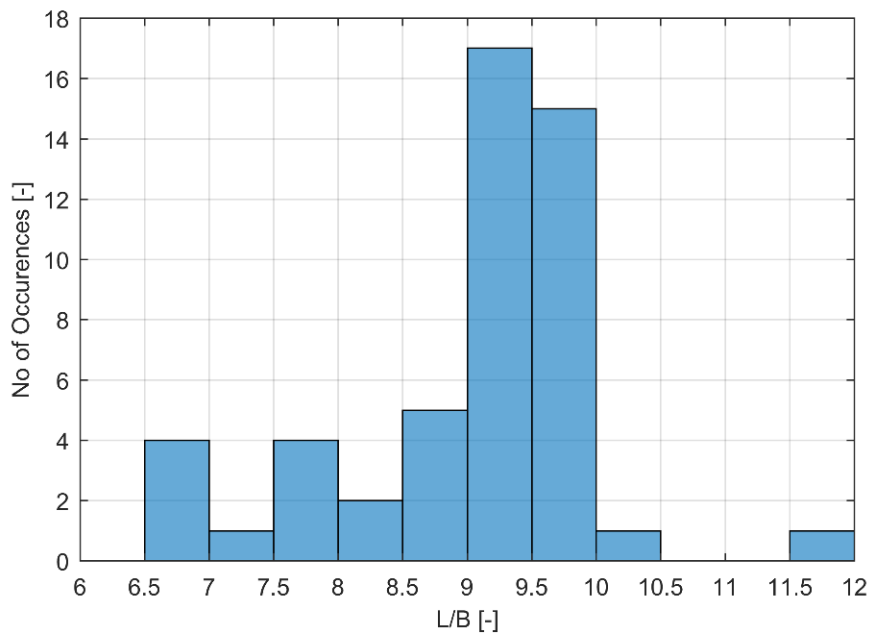

Figure 2 Distribution of L/B in Great Lakes bulk carriers. Based on data in [13]

Lastly, Figure 3 presents the distribution of beam to draught (B/T). It can be noticed that the Great Lakes bulk carriers are characterized by relatively large B/T ratio, likely resulting from the draught limitations being more stringent than beam limitations in channels and rivers.

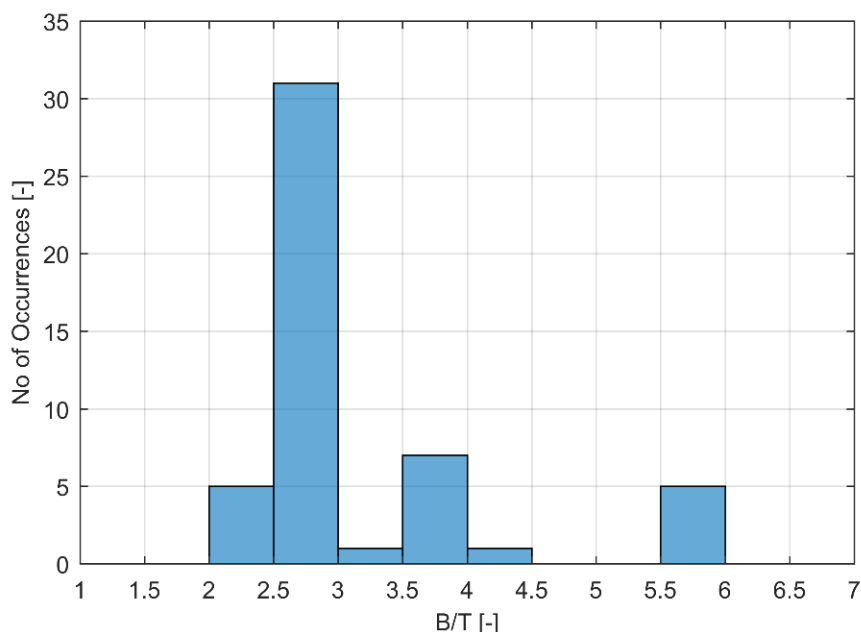

Figure 3 Distribution of B/T in Great Lakes bulk carriers. Based on data in [13]

Considering a semi-empirical straight line stability criterion presented in [14] one will notice that such hull shape can lead to vessels being straight-line unstable. That, in turn, leading to increased steering losses, especially important due to a large block coefficient.

Table 2 contains the extension of data discussed above to the hulls built after the 1972. Basic analysis of the data reveals the strong correlation of block coefficient and length, Figure 4, which, given no change in vessels' speed, can be seen as confirmation of the previous statement with regards to cargo carrying capacity being more important than vessel's speed. Same figure also suggests that there are two length-groups of vessels. First group clustered in the vicinity of 300m (around 1000ft) and the second 200m (around 700ft). Considering the discussion on the operational environment those are easily identified as Poe Lock max and MacArthur Lock max vessels.

Further exploration of Table 2 reveals that there is a relation between the vessel size and number of propellers with the Poe Lock max vessels having two propellers and MacArthur Lock max vessels having one.



Table 2 Representative Great Lake Bulk Carriers built after 1972. Based on [8], [15], and [16]

Parameter	Name	Stewart J. Cort	John J. Boland	Calumet	Sam Laud	St. Clair	Mesabi Miner	Indiana Harbor	Paul R. Tregurtha
Built	-	1972	1973	1973	1975	1976	1977	1979	1981
Length, Overall	m	304.800	207.264	192.024	193.548	234.696	304,8	304,8	308,915
Beam, Mld.	m	31.882	23.774	20.726	20.726	28.042	32.004	32.004	32.004
Draft, Design, Mld.	m	7.849	8.077	7.721	8.516	8.382	8.534	8.382	8.534
Displacement, Mld.	t	69426	34810	25922	29973	49281	77546	76508	78669
Block Coefficient	-	0.924	0.893	0.872	0.903	0.906	0.942	0.946	0.942
Brake Power	kW	11036	5369	4176	5369	8054	11931	10738	11931
Shaft rpm	rpm	121	120	110	120		120	120	120
Number of Screw propellers	-	2	1	1	1	1	2	2	2
Propeller Diameter	m	5.486	5.334	4.877	5.334	5.639	5.334	5.334	5.334
Speed	kn	13.89	13.00	13.37	?	?	13.68	?	?

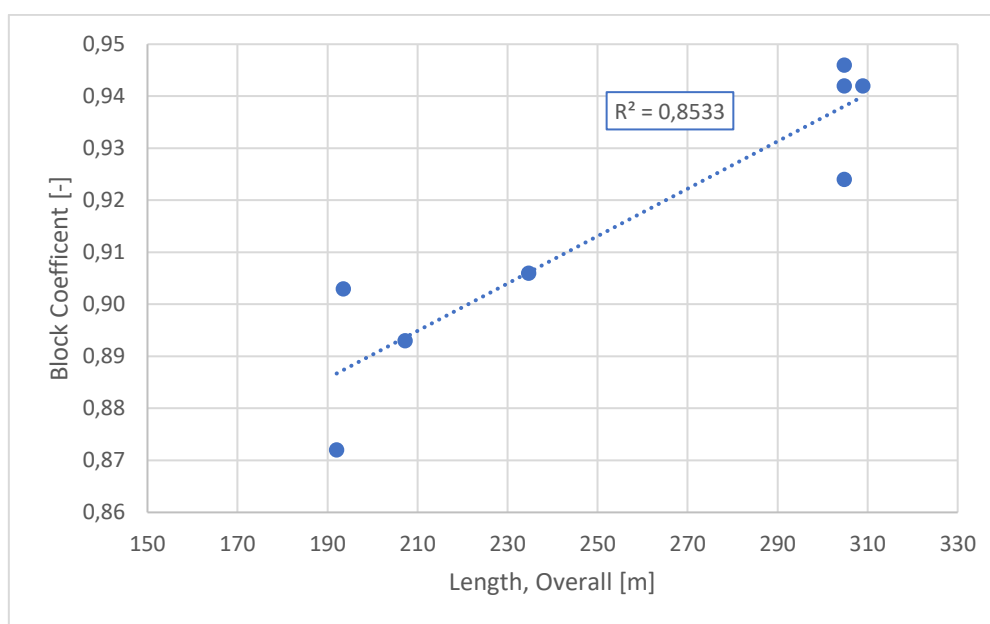

Figure 4 Correlation between block coefficient and the overall length for selected vessels built after 1972

4. Operational profile

Due to waterway freezing, the operations are limited to approximately 270 days per year, [5]. According to [8] a typical Great Lakes self-unloading bulk carrier spends approximately 33% of its operating time at reduced power and in port.

In [17] an example of a typical Great Lakes voyage is presented as a round trip carrying taconite from Duluth to Gary through Lake Superior, Soo Locks, St. Mary's River, Lake Huron and lake Michigan. Approximately 76% of voyage duration is spent in open lake transit condition, during which the propulsion power is utilized on the level of 85%. Docking/undocking, loading and unloading combined take approximately 13% of time. During this time the usage of propulsion power is marginal. Maneuvering and reduced speed operation takes approximately 10% of the total voyage time. During this condition the utilization of propulsion power is on the moderate (30-50%) level.

5. Propulsion system

Most important factors driving the need for propulsive power are vessel's speed, size and hull shape. As it mentioned in point 3 the operating environment of self-unloaders dictates full, large block coefficient shapes, while allowing for comparatively low vessel speeds. This is a compromise as propulsive power requirements increase both: with increase in block coefficient as well as with the increase in speed.

Dominating type of main engine used currently onboard Great Lakes self-unloaders is non-reversing, 4-stroke, diesel engine. Most engines would operate in ranges between 450-550 and 800-900rpm depending on the type of fuel used (the former would use Intermediate Fuel Oil and the later Marine Diesel Oil), [8].

Review of the Table 3, containing American Steamship Company's (major self-unloader owner and operator) fleet listing, indicates that two dominating propulsion system solutions are twin-screw, four-engine and single-screw, twin-engine combinations. Twin-screw solution for larger vessels being an obvious reason of stringent draught limitations.

Table 3 Overview of propulsion power on American Steamship Company's Bulker Fleet [15]

Parameter	Length, Overall	Number of Propelle	Number of Main Engines	Total Propulsi on Power
Vessel	[m]	[-]	[-]	[kW]
American Spirit	306.019	2	2	11931
Burns Harbor	304.800	2	4	10440
Indiana Harbor	304.800	2	4	10440
Walter J. McCarthy Jr.	304.800	2	4	10440
American Century	304.800	2	4	10440
American Integrity	304.800	2	4	10440
St. Clair	234.696	1	3	7830
American Mariner	222.504	1	2	5220
H. Lee White	214.579	1	2	5220
John J. Boland	207.264	1	2	5220
Sam Laud	193.497	1	2	5220
American Courage	193.497	1	2	5220

A non-reversing engine would, through a gear system, be connected to a controllable-pitch propeller (CPP). That allows, through the change in propeller pitch, for developing forward and backward thrust without the need to change the shaft revolution direction. CPP plants on Great Lakes self-unloaders operate in a combinator mode what means that, in general, both the shaftline revolutions and pitch would be subject to change. This would be done in order to operate with maximum, practically obtainable, efficiency throughout the available engine power range or to enable utilization of the full main engine power regardless of the operating condition. Propulsion power control on the bridge would be equipped with one control handle programmed in such a way that for each position of the handle an optimal (in light of energy efficiency) combination of pitch ratio and engine speed is used, [18].

Based on the above observations a typical Poe Lock max, twin-screw, self-unloader's propulsion system layout is drawn and presented on Figure 5.

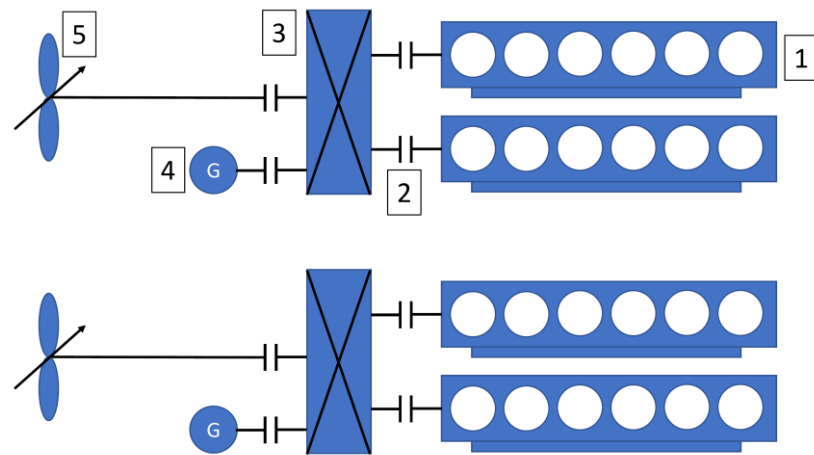

Figure 5 Typical Great Lakes 1000ft self-unloader's propulsion system layout (description in text)

This system would be composed of four 4-stroke diesel engines (1) connected through clutches (2) in pairs to reduction gears (3) each of which connected to a single controllable pitch propeller (5) and attached generator (4). Propeller shafts are exposed and supported by the use of brackets.

Following, a propulsion system of a typical MacArthur Lock max, single-screw, self-unloader is presented on Figure 6.

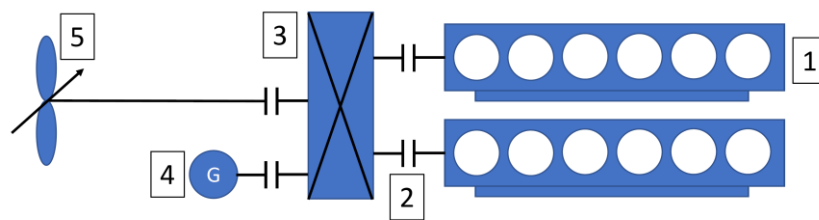

Figure 6 Typical Great Lakes 700ft self-unloader's propulsion system layout (description in text)

This system would be composed of two 4-stroke diesel engines (1) connected through clutches (2) to a reduction gear (3) driving a single controllable pitch propeller (5) and attached generator (4). Propeller shaft exits the hull through center-line skeg.

6. Maneuvering system

As it was already discussed the Great Lakes - St. Lawrence Seaway System in a considerable part consists of confined waters. Due to this fact the navigation can be more demanding than in case of open seas. Considering, in addition, that Great Lakes bulk carriers are characterized by relatively high (when put in comparison with similar-size ocean-going vessels) autonomy of operations as well as large block coefficient and L/B values, the need for good maneuvering characteristics becomes obvious.

Maneuvering system of a vessel could be understood as responsible for keeping the vessel on a desired path. As such, for a vessel autonomous in operation (i.e. not considering tugs etc.), it would consist of active and passive shipboard control devices. With regards to the Great Lakes self-unloaders those would be rudders and transverse tunnel thrusters respectively.

Maneuvering system of a typical Poe Lock max, twin-screw, self-unloader would consist of two rudders and a bow and stern transverse tunnel thrusters, [15] and [17]. A transverse offset between the rudder center-plane and the propeller axis is normally applied, [17]. Such arrangement is usually made for vessels that are deemed to require frequent shaftline repairs and/or in order to avoid the impact from propeller-generated vortex systems. Given the specifics of the vessels under investigation both aspects could be important. Rudders are usually full-spade (all-movable) rudders installed in hull without the headboxes, [17].

Maneuvering system of a typical MacArthur Lock max, single-screw, self-unloader would consist of a rudder and a bow and stern transverse tunnel thrusters, [15] and [17]. Rudder would be placed after the propeller without the transversal offset observed in case of twin-screw vessels, [17].

Inspection of data in Table 4 reveals that entire self-unloader fleet of American Steamship Company is equipped with transverse tunnel thrusters. With an exception of American Spirit both bow and stern thrusters are installed regardless of the size of the vessel.

Table 4 Overview of transverse tunnel thruster power on American Steamship Company's Bulker Fleet [15]

Parameter	Length, Overall	Bow Thruster Power	Stern Thruster Power
Vessel	[m]	[kW]	[kW]
American Spirit	306.019	746	-
Burns Harbor	304.800	1119	1119
Indiana Harbor	304.800	1119	1119
Walter J. McCarthy Jr.	304.800	1119	1119
American Century	304.800	1119	1119
American Integrity	304.800	1119	1119
St. Clair	234.696	746	746
American Mariner	222.504	746	746
H. Lee White	214.579	746	746
John J. Boland	207.264	746	746
Sam Laud	193.497	746	447
American Courage	193.497	746	447

Generally observed, and well known, tendency is such that the effectiveness (understood as crossforce and steering moment) of active control devices decreases with ship speed while the opposite is generally true for passive control devices. Such situation arises due to the fact that the passive control devices, in general, utilize the ship movement to perform their task while active devices work in arrangements that can compromise their performance when ship is sailing ahead at considerable speed. It is then worth noting that the deterioration of thruster performance occurs

approximately in the same vessel speed range where the rudder performance is also poor. This speed range is typical for considerable range of maneuvers such as: transfer through a channel or lock, maneuvering in limited visibility conditions, approaching a pier or another vessel or operation in harbor.

Closely linked to the maneuvering capabilities is also usage of CPPs. Those, besides the capability to improve the propulsive efficiency of vessels with diverse operational modes also considerably increase their maneuverability. They enable slow-speed operation without the limitations imposed on minimum engine rpm, as is the case for fixed pitch propeller plants. They also are able to provide high thrust values at slow vessel speeds thus considerably improving vessel acceleration. CPPs also provide better vessel's stopping abilities due to ability to produce high reverse thrust by simply changing the blade pitch, an operation taking usually between 6-30s which is considerably less than the fixed pitch propeller counterpart in which the engine needs to be stopped and reversed, [18].

7. Conclusions

Paper contains an overview of the propulsion and maneuvering systems' characteristics of U.S. flagged Great Lakes self-unloading bulk carriers. The topic was found important because of the importance of the Great Lakes bulker fleet to the regional economy which remains in contrast to the state of the fleet. A situation that requires and economically justifies the energy- and operational-efficiency related upgrades.

Two size - groups of vessels were identified. First group concentrated in the vicinity of 300m (1000ft) and the second 200m (700ft). Considering the discussion on the operational environment those were identified as Poe Lock max and MacArthur Lock max vessels. Poe Lock max vessels being mainly four - engine, twin - screw and MacArthur Lock max being twin - engine, single - screw vessels.

Due to generally shorter distances between ports than in case of ocean shipping, vessel's cargo-carrying capacity and unloading rate was found to be more important than the vessel's speed. That, along with operation in locks, resulted in very full forms (forms with high value of block coefficient).

It was also found that the Great Lakes self - unloaders are characterized by relatively large B/T ratio, likely resulting from the draught limitations being more stringent than beam limitations in channels and rivers.

Such environmental and operational conditions (and resulting hull form) were found to have a significant impact on propulsion system design and performance. Firstly, they have resulted in a comparatively low installed propulsion power (low required operational speed). Secondly, in relation to limitations in draught, required installation of two propellers on larger vessels.

Similar situation appears to be the case for maneuvering system. Firstly, such hull shapes can lead to vessels being straight - line unstable, what, in turn, leads to increased steering - related energy losses, especially important due to a high value of block coefficient. Secondly, it was noticed that the speed range in which the deteriorated performance of the active and passive control devices happens can overlap with the speed range in which considerable range of maneuvers of self-unloaders are carried: transfer through a channels or locks, maneuvering in limited visibility conditions, approaching a pier or another vessels or operation in harbor.

References

- [1] Martin Associates, "The Economic Impacts Of The Great Lakes - St. Lawrence Seaway System," Martin Associates, Lancaster, 2011.
- [2] Transport Canada, U.S. Department of Transportation, "Great Lakes St. Lawrence Seaway Study," Transport Canada, U.S. Department of Transportation, 2007.



- [3] American Shipping Company, "U.S. Jones Act background," [Online]. Available: <http://www.americanshippingco.com/s.cfm/2-18/US-Jones-Act>. [Accessed 15 10 2018].
- [4] U.S. Department of Transportation, "U.S. Water Transportation Statistical Snapshot," U.S. Department of Transportation, 2013.
- [5] J. Marshall, Interviewee, *Senior Business Development Manager, Wartsila North America*. [Interview]. 15 10 2018.
- [6] Martin Associates, "Economic Impacts Of Maritime Shipping In The Great Lakes - St. Lawrence Region," Martin Associates, Lancaster, 2018.
- [7] American Great Lakes Ports Association, "The Great Lakes Seaway Navigation System," [Online]. Available: <http://www.greatlakesports.org/industry-overview/the-great-lakes-seaway-navigation-system/>. [Accessed 28 06 2018].
- [8] T. Lamb (ed.), *Ship Design and Construction. Volume II, The Society of Naval Architects and Marine Engineers*, 2004.
- [9] Marine Traffic, "Burns Harbor," [Online]. Available: <https://www.marinetraffic.com/en/ais/details/ships/shipid:428970/mmsi:366901880/vessel:BURNS%20HARBOR>. [Accessed 28 06 2018].
- [10] J. Dudziak, *Ship Theory* (in Polish), Fundacja Promocji Przemysłu Okrętowego i Gospodarki Morskiej, 2008.
- [11] D. Taylor, K. Hall and N. MacDonald, "Investigations into Ship Induced Hydrodynamics and Scour in Confined Shipping Channels," *Journal of Coastal Research*, 12 2007.
- [12] Lake Carriers Association, "An Overview of Our Industry," [Online]. Available: <http://www.lcaships.com/industry/>. [Accessed 26 06 2018].
- [13] P. Swift, H. Nowacki and J. Fischer, "Estimation of Great Lakes Bulk Carrier Resistance Based on Model Test Data Regression," University of Michigan. Department of Naval Architecture and Marine Engineering, 1972.
- [14] T. I. Fossen, *Guidance and Control of Ocean Vehicles*, John Wiley and Sons, 1994.
- [15] American Steamship Company, "ASC's Fleet," [Online]. Available: <http://www.americansteamship.com>. [Accessed 28 06 2018].
- [16] Interlake Steamship Corporation, "Our Fleet," [Online]. Available: <http://www.interlake-steamship.com/our-fleet>. [Accessed 01 07 2018].
- [17] M. Parsons, D. Singer and S. Denomy, "Integrated Electric Plants in Future Great Lakes Self-Unloaders," *Journal of Ship Production and Design*, vol. 27, no. 4, pp. 169-185, 2011.
- [18] C. Dymarski, *Controllable Pitch Propellers. Design and control* (in Polish), Wydawnictwo Politechniki Gdanskiej, 2011.

