

RETROFIT ANALYSIS OF FLORIDA BEAM-AND-POST REINFORCED CONCRETE BRIDGE BARRIERS

J. W. Wekezer¹, I. Kreja², M. Issa³

¹**FAMU-FSU College of Engineering,**
2525 Pottsdamer Street,
Tallahassee, FL 32310-6046, USA

²**Gdańsk Technical University,**
ul. G. Narutowicza 11/12,
80-952, Gdańsk

³**Florida DOT,**
605 Suwannee Street, MS 33,
Tallahassee, Florida 32399-0450, USA

The major objective of the study was to evaluate crashworthiness of the existing Florida Beam-and-Post reinforced concrete bridge barriers. These barriers were first installed thirty years ago, they are still popular, and represent a significant investment in transportation infrastructure of the State. The major emphasis of the paper is focused on utilization of computational mechanics to improve safety of the existing reinforced concrete bridge rails. It presents results of analytical efforts to simulate crash impacts between a pickup truck and the Florida Beam-and-Post barrier. Computer calculations were performed using LS-DYNA, explicit, dynamic, 3-D finite element code. Finite element models of a 2000P Chevrolet pickup truck and the model of the bridge barrier were used to simulate test 3-11 per NCHRP Report 350. Computer simulations revealed severe snagging problems and provided input for a better understanding of the barrier response. Specific recommendations for a retrofit of the existing Florida Beam-and-Post barriers were provided. These recommendations include guidelines for new, proposed, safe reinforced concrete bridge barriers for consideration by transportation engineers.

1. INTRODUCTION

Significant improvements in highway and bridge safety have been achieved through a multitude of actions over the past three decades, but one area where serious problems still exists is the highway roadside. Highway and bridge designers have developed several generations of barriers to address the safety problems.

These comprehensive efforts also address safety improvements of older bridge barriers, since their replacement is not as easy as compared with less expensive roadside traffic guardrails. Although only 1.3% of the total fatalities result from impacts with bridge barriers, their upgrading has one of the highest cost – benefit ratio [19].

The Federal Highway Administration (FHWA) initiated efforts to utilize modern computing technology in the early 1990's. Computational mechanics has been aimed at providing an improved insight and understanding of crash-worthiness response of roadside safety structures. Finite element technology provides better and more reliable analytical tools to study all critical components of both: a vehicle and a barrier during the crash. Stop-action capabilities allow millisecond-by-millisecond crash analysis, and once the model is created, it can be used to conduct unlimited crash simulations. Computer simulations provides insight into damage mechanism and explanation of full-scale crash results, if they exist. Crash simulations facilitate parametric studies, which are generally impossible with traditional crash testing. They also allow for evaluation of impact scenarios that are otherwise un-testable.

Dynamics and safety of roadside and bridge barriers have been successfully studied over the past thirty years using BARRIER VII program, [23]. This non-linear, dynamic code allowed for simple geometric definition of guardrails and vehicles, and is still used by some roadside designers. However, rapid development of new computing software [9, 18] has allowed for higher level of analysis to include snagging between protruding vehicle parts against barrier beams, posts, curbs, effects of the post setback distance, component failure, and many others.

LS-DYNA was selected for impact simulation of a 1994 Chevrolet C-1500 pickup truck with the Florida Beam-and-Post bridge barrier. The program is a version of DYNA3D [37], its predecessor, developed earlier and distributed as a public domain code by Lawrence Livermore National Laboratory (LLNL). Both programs are three-dimensional, nonlinear, dynamic explicit codes suitable for studying impacts and collisions. The development of several finite element models of motor vehicles was sponsored by the FHWA to be used as realistic models of impactors with roadside safety structures. The first model of this type, 1991 GM Saturn, was developed by Wekezer *et al.*, [36]. Library of the FE models of motor vehicles includes: 1981 Honda Civic [6], 1990 Ford Festiva [25, 26, 36], 1991 Ford Taurus [31], 1994 Chevrolet C-1500 pickup truck [38, 39, 40, 41], and many others. Finite element models of standard class of motor vehicles are constantly developed to cover a broader spectrum of test levels per NCHRP Report 350 [30].

Existing models of the vehicles are used in ongoing efforts to improve roadside safety structures. Several interesting crash studies of vehicles impacting safety structures were conducted. They include: MELT guardrail terminal [25],



transformer base luminaire support [20], modified three-beam guardrail [21, 22], Nebraska turned-down terminal, dual support breakaway terminal, Buffalo rail, a United States Postal Service mailbox [27, 28, 29], slip-base luminaire support [2], G2 guardrail [10, 11, 12], BCT terminals [33], and many others.

The present paper outlines the research efforts of using this technology to evaluate crashworthiness of an existing Florida Beam-and-Post reinforced concrete bridge barrier. Crash simulations indicated severe snagging characteristics of the barrier, which confirmed earlier Florida Department of Transportation (FDOT) concerns from accident reports and analyses. Over thirty computer simulations were performed. The simulations conducted for the original barrier helped to quantify sources, amount and nature of snagging by correlating acceleration peaks with major snagging events. As a result of the research, several specific recommendations (including full-scale crash tests) were made to the FDOT regarding feasible structural retrofits of the bridge barrier.

2. FLORIDA BEAM-AND-POST BARRIER

The Florida Beam-and-Post bridge barrier was used on majority of bridges in the state of Florida in the early 1970's. At that time the design specification called for the application of a 44.4 kN (10-kip) static load at key locations on the railing as well as for some dimensional requirements for the openings between rail elements and other cross section geometry [1]. Full-scale crash tests of the railings were not required at that time, and they were never performed. The post cross section is 10" x 12" (254 x 305 mm) reinforced with three # 7 (22.2 mm) bars in the traffic side face and three # 5 (15.9 mm) bars in the other side. All the bars are spaced at 3 in. (76.2 mm) with 1.5 in. (38.1 mm) concrete cover. The posts are spaced at 1.80 m center-to-center with nominal height of 0.90 m. The post could be connected at the bottom to another longitudinal beam or to an end bent wing with the required reinforcement. The top beam connects all the posts together to form the railing. A typical top beam cross section is 8" x 13.5" (203 x 343 mm) reinforced with 3 # 7 (22.2 mm) bars spaced equally on both side of the beam and confined with # 3 (9.5 mm) stirrups. The open space between the rail elements is about 0.3 m high by 1.5 m wide. A 3/4" (19 mm) diameter is used at all edges of beams and posts. The number of continuous panels (beams and posts) depends on the length of the structure. For long structures 19 ft expansion joints were provided. The 28 days concrete strength was required to be 3,750 psi (25.875 MPa) and the reinforcing steel was specified as grade 60 minimum grade 40 (414 and 276 MPa respectively). A typical example of the Florida Beam-and-Post bridge barrier is shown in Fig. 1.

Full-scale crash tests for different concrete bridge rails were successfully conducted in several states. They included Tennessee [4], Nebraska [7, 15], Iowa [32],



FIG. 1. An example of the Florida Beam-and-Post reinforced concrete bridge barrier (see text for description and dimensions).

and Texas [13, 14]. Although they may look somewhat similar, differences between them necessitated conducting individual and independent full-scale crash tests. Florida Beam-and-Post bridge rail is an earlier and different design as compared with those in other states. This bridge rail was never tested. However, analytical studies were conducted, and they are reported in this paper. Unfortunately, acceleration histories and other generated data cannot be compared with those from “similar” barriers. These results can only be verified by new, full-scale crash tests conducted for the Florida Beam-and-Post bridge rail.

3. FINITE ELEMENT MODELS

Two finite element models of a 1994 Chevrolet C-1500 pickup truck were developed by the National Crash Analysis Center in Washington D.C., [38] – [41]. One of them (called: detailed model) includes almost 50,000 finite elements, while its smaller counterpart (reduced model) consists of almost 10,000 finite elements.



The reduced model was used for all impact cases presented in this study. The model represents the 2000P class of vehicles (see Fig. 2), as referenced in NCHRP Report 350 [30].

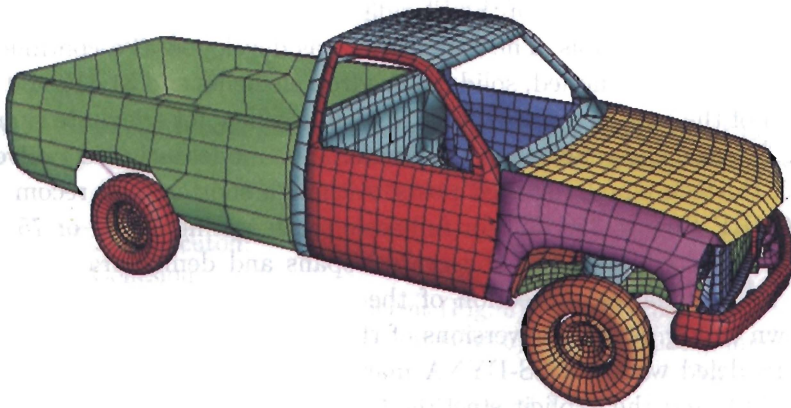

FIG. 2. 1994 Chevrolet C-1500 pickup truck. Top: a general view of the truck. Bottom: a reduced finite element model of the truck [38] – [41].

The reduced model was developed specifically to address vehicle safety issues roadside hardware design. The vehicle is a regular-cab, fleetside long-box 1500 with a total length of 5.4 meters and a wheel base of 3.34 meters with mass of 2000 kg. The reduced model consists of 10,723 nodes, 8,721 shell elements, 34 beam elements, 337 hexahedron elements and 37 different material

models. Three LS-DYNA material models were used in the reduced truck model: Elastic (No. 1) with 9 data components, Rigid (No. 20) with 4 components, and Piecewise Linear Isotropic Plastic (No. 24) with 24 components.

The 2000P pickup truck model has been recognized as a reasonably accurate finite element model of a vehicle, which can be used for simulations on single processor workstation computers. Fidelity of the model was examined in [24], while detailed results of validation studies were provided in [38] through [41].

Test levels specified in NCHRP Report 350 require crash tests with both the 820C and the 2000P vehicles. Although the original model developed by the NCAC was based on the $1/2$ ton vehicle (i.e. Chevrolet C-1500), the reduced model was modified to reflect the characteristics of a $3/3$ ton pickup (i.e. Chevrolet C-2500) to address requirements of the NCHRP Report 350. The mass of the vehicle was also increased from 1800 kg to 2000 kg by adding 200 kg at the location of the center of gravity.

The recommended test matrix for longitudinal barriers, contained in NCHRP Report 350 [30], includes two tests: one with a small passenger car and one with a pickup truck. The 2000P vehicle is the larger of the two vehicles, with more severe snagging effects expected, and successful simulations between it and the barrier would provide an evidence of a good barrier design relative to strength requirements. The pickup truck model was therefore selected for this study.

Two finite element models of the Florida Beam-and-Post were initially developed for LS-DYNA analysis. The first model was developed as a continuous rail comprising 23,170 eight-noded, solid hexahedron elements and 31,419 nodes. The total length of the section modeled was 18.59 m to allow for adequate simulation of contact between the vehicle and the barrier. The model included twelve beam spans with thirteen equally spaced posts. Although shorter than recommended by the NCHRP Report 350 [30] for full-scale crash testing (23 m or 75 ft), the model was impacted at one of the central spans and demonstrated negligible effects at its boundaries. A section of the finite element model of the bridge rail is shown in Fig. 3. Earlier versions of the model consisted of two materials: concrete, modeled with the LS-DYNA material No. 16 (pseudo-tensor geological model, [9]), and the explicit steel reinforcement modeled as beam elements. More reliable results were obtained when smeared, hexahedron finite elements were used due to relative coarseness of the models.

The second barrier model included expansion joints. This model was constructed of 23,656 eight-noded hexahedron smeared elements (Note: the concept of the smeared elements is explained in the section: Material Properties and Modeling of the paper), and 33,068 nodes for a total length of 18.916 m of the modeled bridge barrier section. Since this model consisted of two 9.144m bridge rail sections, with one expansion joint in the middle, modeling of other sections of the barrier would have been obviously redundant.



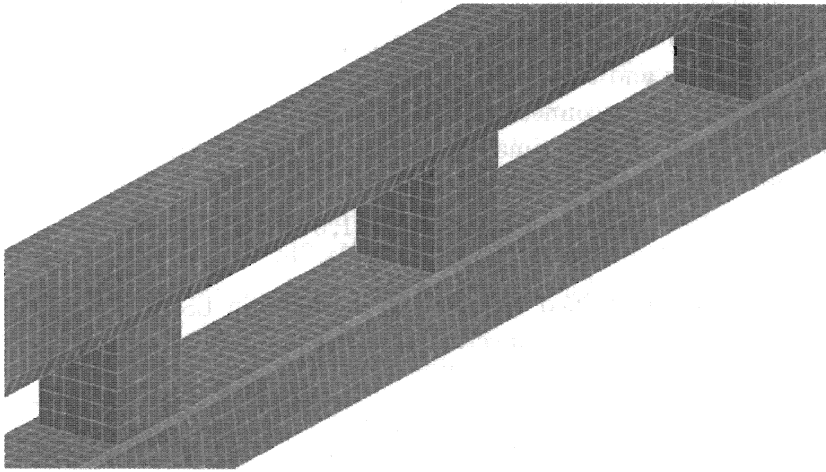

FIG. 3. Florida Beam-and-Post bridge barrier. A typical section of the finite element model developed for LS-DYNA analysis.

Material properties for concrete and steel as specified in Table 1 were used for all simulations. As a result of subsequent modification efforts, two additional models of the Florida Beam-and-Post barriers with retrofitted W-beam rubrail were also constructed.

Table 1. Material model parameters used for Bate's experiment [3]. (Note: parameters of reinforcement for smeared reinforcement option were taken as for steel re-bars, see: "Steel").

Concrete, material model No. 16	Tensile cutoff: Cohesion: Pressure hardening coefficient (Fig. 5): Pressure hardening coefficient (Fig. 5): Cohesion for failed material: Pressure hardening coefficient for failed material: Damage scaling factor: Damage curve: Equation of state: Percent reinforcement:	$\sigma_f = 3.13 \text{ MPa}$ $a_0 = 7.826 \text{ MPa}$ $a_1 = 0.3333$ $a_2 = 0.01065 \text{ mm}^2/\text{N}$ $a_{0f} = 3.13 \text{ MPa}$ $a_{1f} = 1.5$ $b_1 = 1.25$ defined in Fig. 6 defined in Fig. 7 $p_r = 1.23 \%$
Steel	Young modulus: Poisson's ratio: Yield stress: Hardening modulus: Mass density:	$E = 206,800 \text{ MPa}$ $\nu = 0.3$ $\sigma_Y = 303.4 \text{ MPa}$ $E_T = 758.4 \text{ MPa}$ $\rho = 7.823 \cdot 10^{-9} \text{ N} \cdot \text{s}^2/\text{mm}^4$

Initial simulations were performed with the W-beam connected to the concrete post with the 8-mm diameter steel bolts. These connections were later found unsatisfactory and they were replaced by 16-mm bolts. The limiting normal force, S_n , for such a connection was taken as 20,000 N, [11]. Consequently, the limit shear force, S_s , is estimated according to the relation:

$$(3.1) \quad S_s = \frac{S_n}{\sqrt{3}} = \frac{20,000}{\sqrt{3}} = 11,547\text{N}.$$

The models of constrained connections available in LS-DYNA contain the “constrained-spotweld” type connection that can be used with a brittle failure criterion:

$$(3.2) \quad \left(\frac{|f_n|}{S_n}\right)^2 + \left(\frac{|f_s|}{S_s}\right)^2 \geq 1$$

where f_n and f_s are the normal and shear interface forces, respectively.

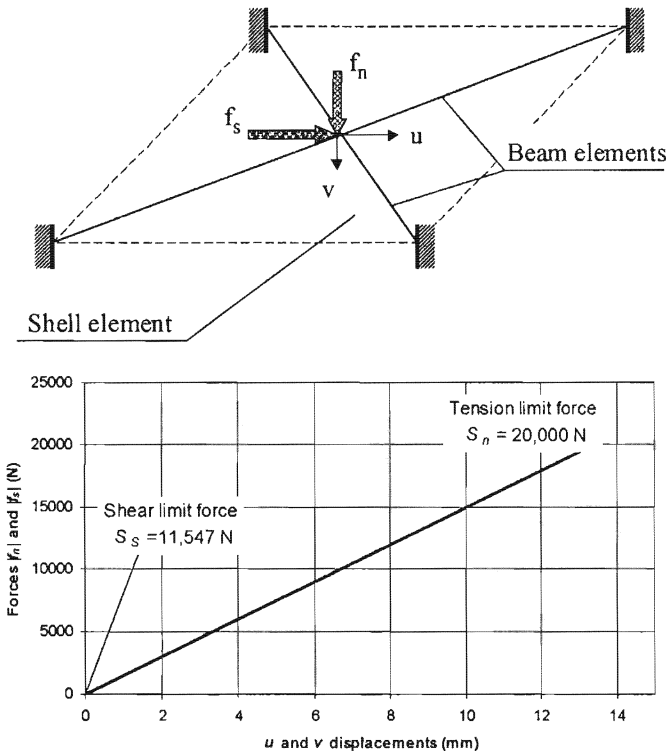

FIG. 4. Model of the bolted connection. Top: a grid of four beam elements connecting a spotweld on the post with four nodes in the W beam. Bottom: shear and tension force–displacement characteristics assumed for FE models of bolts.

Bolted connections were earlier examined in [11]. The study confirmed an intuitive observation, that ductile mode rather than brittle prevails in bolt failures. A simple bolt model was developed as shown in Fig. 4 (top) in order to capture an initial elastic behavior and ultimate ductile failure of the bolt. The model includes four beam elements, which link a spotweld on a shell element of the post with four adjacent nodes on a W beam. The assumed linear force – displacement diagrams for tension and shear, and their limiting values at failure (20.0 kN for tension and 11.547 kN for shear) are shown at the bottom of Fig. 4, which illustrates the assumed bolt characteristics and failure criteria. Failure of the 8-mm bolt is clearly visible in Fig. 15, test 6-4, discussed later in the paper. Final computer runs with 16-mm bolts indicated that the redesigned connections were satisfactory.

4. MATERIAL PROPERTIES AND MODELING

A validation process is routinely conducted whenever data from other sources is available. The process allows establishing a level of confidence with which finite element models of the vehicle and the barrier were built. It requires using at least one of several available validation procedures to statistically compare the acceleration histories obtained from full-scale crash tests (if available) and from computer analysis. The Florida Beam-and-Post barrier is an older bridge barrier, for which the full-scale test results were not available. Had they been available, the vehicle characteristics would have been entirely different than those specified in the more recent NCHRP Report 350. Due to the lack of experimental data, a comparison study was conducted to determine reliability of the finite element models. The major objective of this part of the study was to establish the most appropriate material properties and the best material model from all the currently available LS-DYNA models.

Very few experimental results for dynamic testing of reinforced concrete components were found in the literature. The present study was finally based on an experimental drop test for a simply supported reinforced concrete beam performed by Bate [3]. The reported results consisted of the maximum dynamic deflection obtained for the increased height of the drop of a 90.5-kg hammer. The experimental setup is depicted in Fig. 5.

Bate provided an incomplete description of the material properties he used, therefore most of the parameters required by LS-DYNA could only be estimated. According to basic characteristics of concrete obtained from Bate, the compressive strength of concrete was between 31.3 and 31.8 MPa. The two 1.27-mm diameter reinforcement bars were described as mild steel characterized by yield stress equal to 299.6 – 310.2 MPa, and tensile strength of 442.6 – 469.9 MPa. Averaged values were assumed for all computer runs.

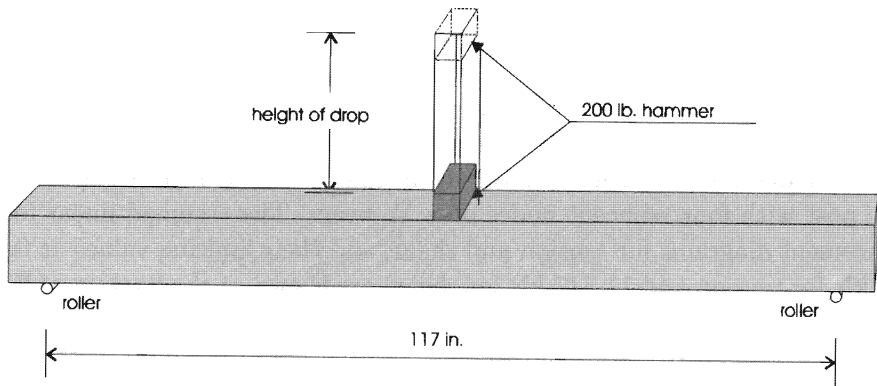

FIG. 5. Bate's experiment [3]: a drop test for a simply supported beam (Note: mass of a hammer = 90.50 kg, span of the beam = 2.972 m.).

The mass density for the concrete was assumed to be $\rho = 2.405 \cdot 10^9 \text{ N} \cdot \text{s}^2 / \text{mm}^4$. The Young modulus was estimated based on the compressive strength of concrete, f_c' , taken as 31.3 MPa:

$$(4.1) \quad E = 4,733 \cdot \sqrt{f_c'} = 4,733 \cdot \sqrt{31.3 \text{ MPa}} \approx 28,480 \text{ MPa}.$$

The value of Poisson's ratio ν was taken as 0.18. The following LS-DYNA material models were considered for modeling concrete (Hallquist, 1994):

No. 3 - elastic-plastic with von Mises yield criterion and kinematic-isotropic strain hardening,

No. 13 - simplified non-iterative elastic-plastic material model, von Mises yield criterion, isotropic strain hardening with failure option,

No. 16 - Concrete/geological material model with two yield stress-pressure functions and smeared reinforcement, and

No. 78 - Soil/concrete material model with deviatoric, perfectly plastic, pressure-dependent yield function in tabulated form.

The material parameters finally adopted in the numerical analysis for concrete (material model No. 16) and steel are summarized in Table 1. Input data for material model No. 16 were prepared according to guidelines provided in Whirley and Engelmann, 1993.

A finite element model of Bate's simply supported reinforced concrete beam was built as shown in Fig. 8. Double symmetry of the beam was taken into account and one quarter of the beam was modeled with the proper boundary conditions at the planes of symmetry. Re-bars were modeled explicitly with 78 truss elements for the quarter of the beam. The location of the re-bar is indicated by a dot in the first cross-section in Fig. 9 which is described as Mat. 16 at the top.

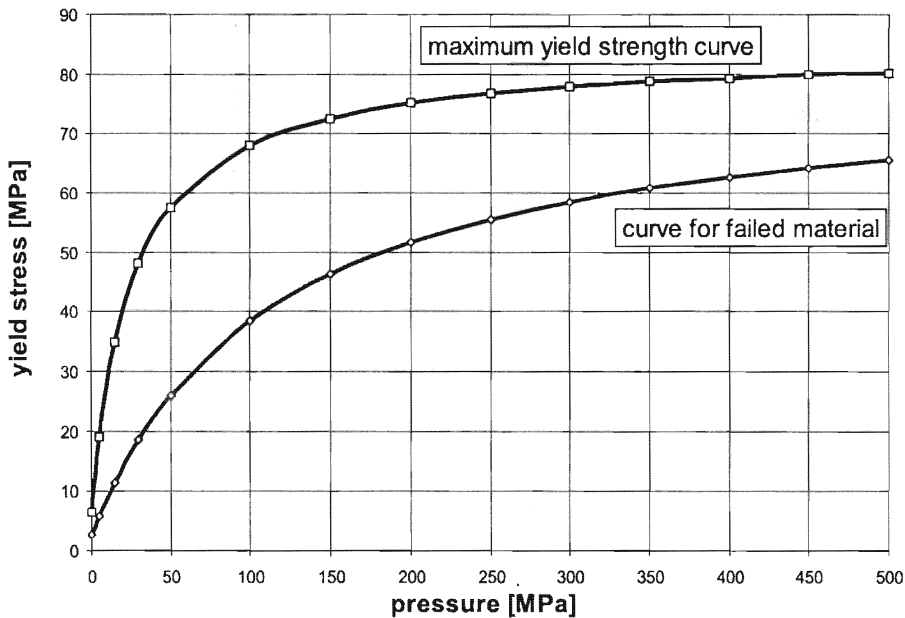

FIG. 6. Assumed pressure-hardening curves for material no. 16, Whirley *et al.*, 1993.

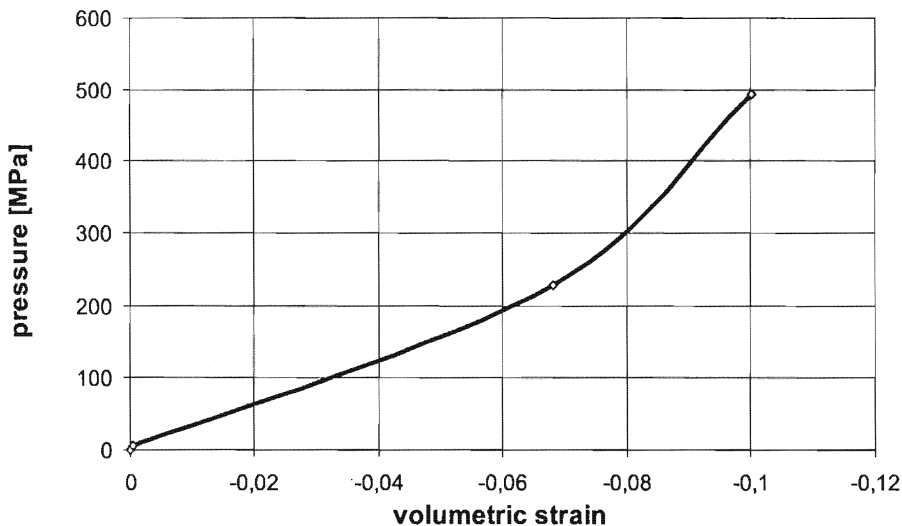

FIG. 7. Assumed equation of state for material no. 16, Whirley *et al.*, 1993.



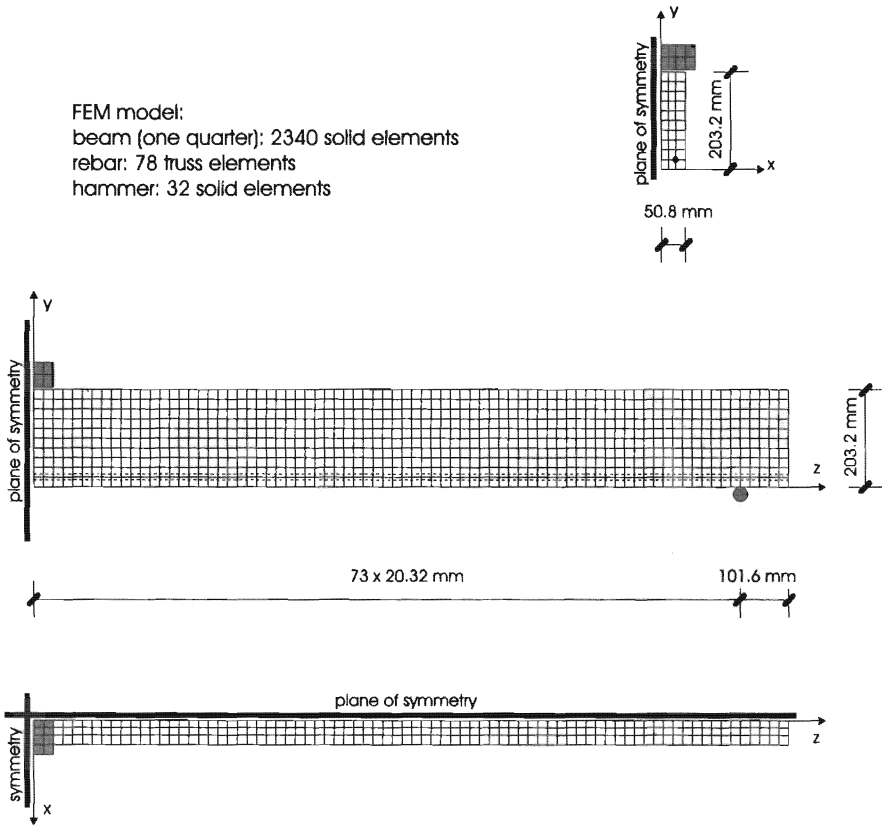

FIG. 8. Finite element model of a symmetric quarter of a simply supported reinforced concrete beam (Bate, 1961).

Smearred elements are commonly used in finite element analyses and they were also considered in this study. A smeared element can be thought of as a solid element with combination of steel and concrete material properties (Table 1), and they often yield reliable solution (Hallquist, 1994). The smeared properties could be assigned either to all elements in the cross section or to the area immediately surrounding the location of the re-bar. In the second model depicted in Fig. 9 as Mat. 16s, the steel properties were equally distributed over the whole cross section with reinforcement ratio of $p_r = 1.23\%$. A more adequate representation of the reinforcement has been adopted in the third model shown in Fig. 9 (Mat. 16ns), where smeared properties were only assumed in the two bottom layers of the final elements with $p_r = 6.15\%$ and with no smeared reinforcement included in the rest of the beam.

Further improvements in the accuracy of the numerical model used in the analyzed impact example can be achieved when strain-rate effects are considered.

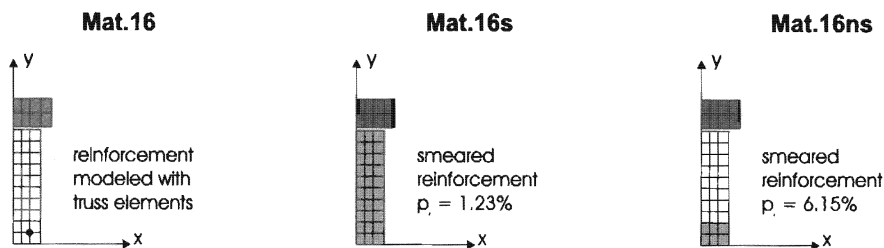

FIG. 9. Three options considered for modeling re-bars in the reinforced concrete beam.

Experiments show that strength of materials subjected to high loading rates may be higher than in a case of a static load. The increase of yield strength of steel at high straining rates is described by the empirical Cowper-Symonds equation (4.2), Jones, 1989:

$$(4.2) \quad \frac{\sigma_y^D}{\sigma_y} = 1 + \left(\frac{\dot{\epsilon}}{D} \right)^{\frac{1}{p}}$$

where σ_y is material yield strength, σ_y^D stands for dynamic yield strength, $\dot{\epsilon}$ represents the strain rate, and D and p are two material parameters, which vary with specific steel type. Jones (1989) recommends to use the values of $D = 40.4$ and $p = 5$ for structural steel. The Cowper-Symonds equation (4.2) is widely accepted by steel researchers and its influence on beam deflection is depicted in Fig. 10.

In contrast, a simple, commonly used strength enhancement factor for concrete under impact loading does not exist. Several different predictions of the strain-rate effect on concrete behavior are provided by various authors. Some of these predictions are presented in Fig. 10 and are shown together with an average formula adopted by the authors in this paper. The Bate's drop experiment has been replicated, where the input parameters for concrete material model No. 16 were modified to include the strain-rate effect. Both versions of material del No. 16, i.e., the one with smeared reinforcement and that with explicit bars, were considered in computer calculations. Mechanical properties of steel, listed in Table 1, were assigned for all re-bars.

Explicit re-bars required careful modeling and the inclusion of the strain rate effect in material model No. 3 used for steel.

The inclusion of the strain-rate effect, as one can see from Fig. 11, had a strong influence on the maximum mid deflection of the Bate's beam.

The final numerical prediction of the maximum midpoint deflection of the beam exceeded the experimental value for model Mat. 16 by about 35%, as compared with 14% for material model Mat. 16ns.



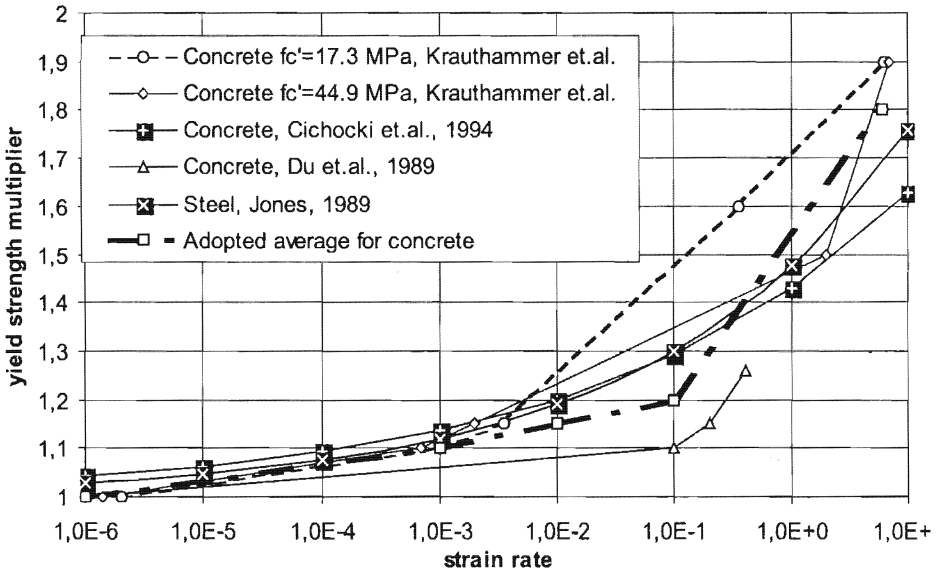

FIG. 10. Yield stress enhancement due to strain-rate effect.

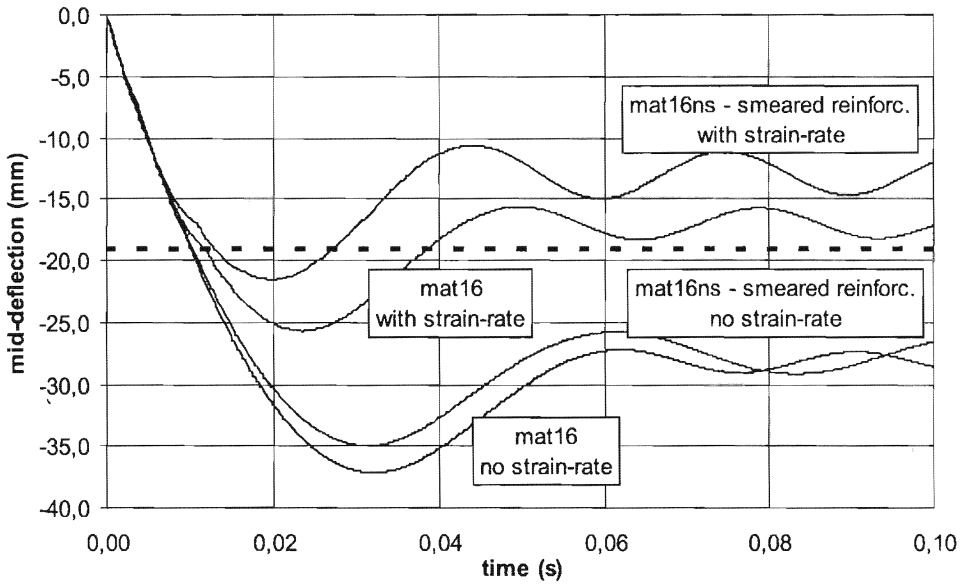

FIG. 11. The strain-rate effect for Bate's beam, $h = 609.6$ mm, material model No. 16. Dashed line represents the total, maximum dynamic deflection of the beam = -19.05 mm, as estimated from Bate's experiment.



Results of numerical simulations indicated that of all LS-DYNA material models examined and available at the time of this study, Mat. 16 model appeared to be the most appropriate for concrete modeling in impact analysis (Wekezer *et al.*, 1997 and Gilbert, 1997). This material model was adopted in final crash simulations of the Florida Beam-and-Post bridge barrier.

5. ANALYSIS

Two finite element models of the Florida Beam and Post barrier were originally developed. The first model (as shown earlier in Fig. 3) represented a continuous barrier with posts spaced at 1.524 m, and with no expansion joints. The second was modified to include expansion joints at 9.144 m with increased post spacing to 1.828 m. The material models and input parameters were selected as listed in Table 1. Crash scenarios included a 2000P pickup truck impacting both barrier models at 100 km/hr and 25 degree angle. All other impact parameters for computer analyses performed are included in Table 2:

Table 2. Summary of computer simulations matrix with FDOT and Modified FDOT Beam-and-Post bridge rail.

Simulation No.	Barrier model	Post spacing	Point of impact
6-1	Without expansion joints	1.524 m	Center of post
6-2	Modified, without expansion joints	1.524 m	Center of post
6-3	With expansion joints	1.828 m	152 mm from post
6-4	Modified, with expansion joints	1.828 m	152 mm from post

Time duration for all simulations was determined at 225 milliseconds, which corresponded to initial phases of re-bouncing the vehicle from the barrier. Coefficients of friction were assumed as follows:

between vehicle and barrier: $\mu_{static} = 0.35$ $\mu_{dynamic} = 0.3$,
 between vehicle and ground: $\mu_{static} = 0.60$ $\mu_{dynamic} = 0.5$.

An orthogonal friction model was used between the tires and ground. The efficient of friction between the vehicle and the ground was applied in transverse direction only. The friction coefficients for the longitudinal direction were assumed as zero to represent free rolling wheels with no braking action.

Initial computer runs confirmed earlier concerns regarding severe snagging, indicated by accident reports. However, strength of the barrier, displacements and all other barrier structural characteristics were found to be satisfactory.

Reducing the existing snagging effect in the original barrier was the main objective of a follow-up retrofit design of the Modified FDOT Beam-and-Post



rail. A W-beam rubrail (as shown in Fig. 12) was recommended over the front of the posts to promote smooth interaction between the post and the vehicle. A cross-section of the resulting combination barrier can be seen in Fig. 13. The standard W-beam is used in several different barriers and can vary slightly in dimensions. Two additional finite element models were created (both with W-beam rubrails, Table 2), with and without expansion joints. The material properties for concrete were used as specified previously in Table 1.

Acceleration histories for the original and the modified Florida Beam-and-Post barriers are shown in Fig. 14. It should be noted that all data presented in Fig. 14 and 16 were averaged over 10 millisecond intervals. While severe snagging effects are indicated in Fig. 14 by the maximum acceleration of -45 g for the original barrier, the simulation for the modified barrier under the same crash scenario demonstrated reduction of accelerations to about -22 g. The acceleration data serves as computational evidence, that the proposed bridge rail (retrofitted with a W-beam rubrail) is characterized by ride down accelerations, which are reduced by approximately 50%. It clearly provides much safer environment during a crash impact.

The results should be interpreted very carefully. Although extensive efforts were made to identify proper material models and material properties in this research, the full-scale crash test data were not available to the authors. Therefore, finite element models of all bridge barriers developed were not considered by the authors to be fully validated, and quantitative benefits from using the modified barriers cannot be uniquely estimated. The authors feel however that the presented analysis can be considered at least as qualitative. The conducted study clearly shows the improvement of the proposed modified Florida Beam-and-Post barrier retrofitted with a W-Beam. The results can be validated through recommended, follow up full-scale crash tests.

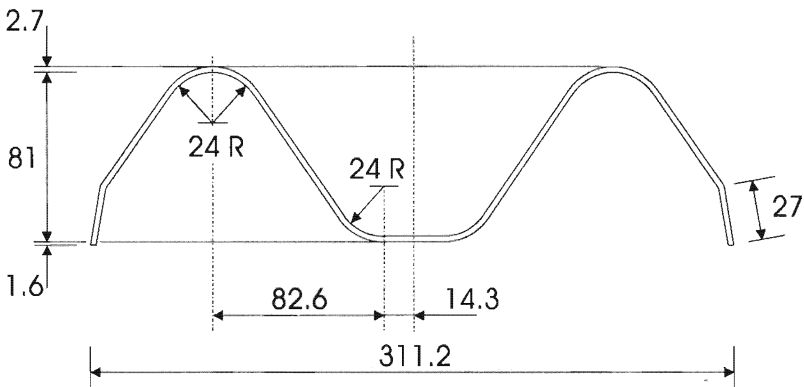

FIG. 12. Cross-section detail of the W-beam.



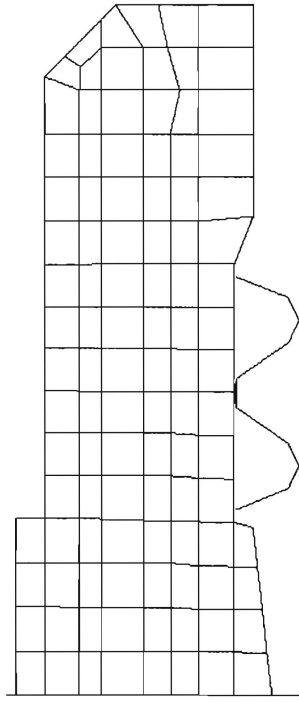

FIG. 13. 2-D cross-sectional view of FE model of Modified FDOT Beam-and-Post rail.

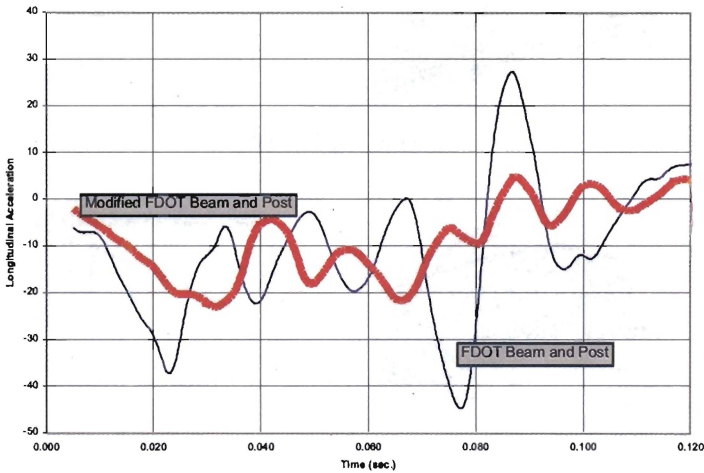

FIG. 14. Acceleration histories for the original and the modified Florida Beam-and-Post ridge barrier, simulations 6-3 and 6-4. Note: longitudinal accelerations (vertical axis) are provided in terms of earth acceleration g . Data averaged over 10 milliseconds.



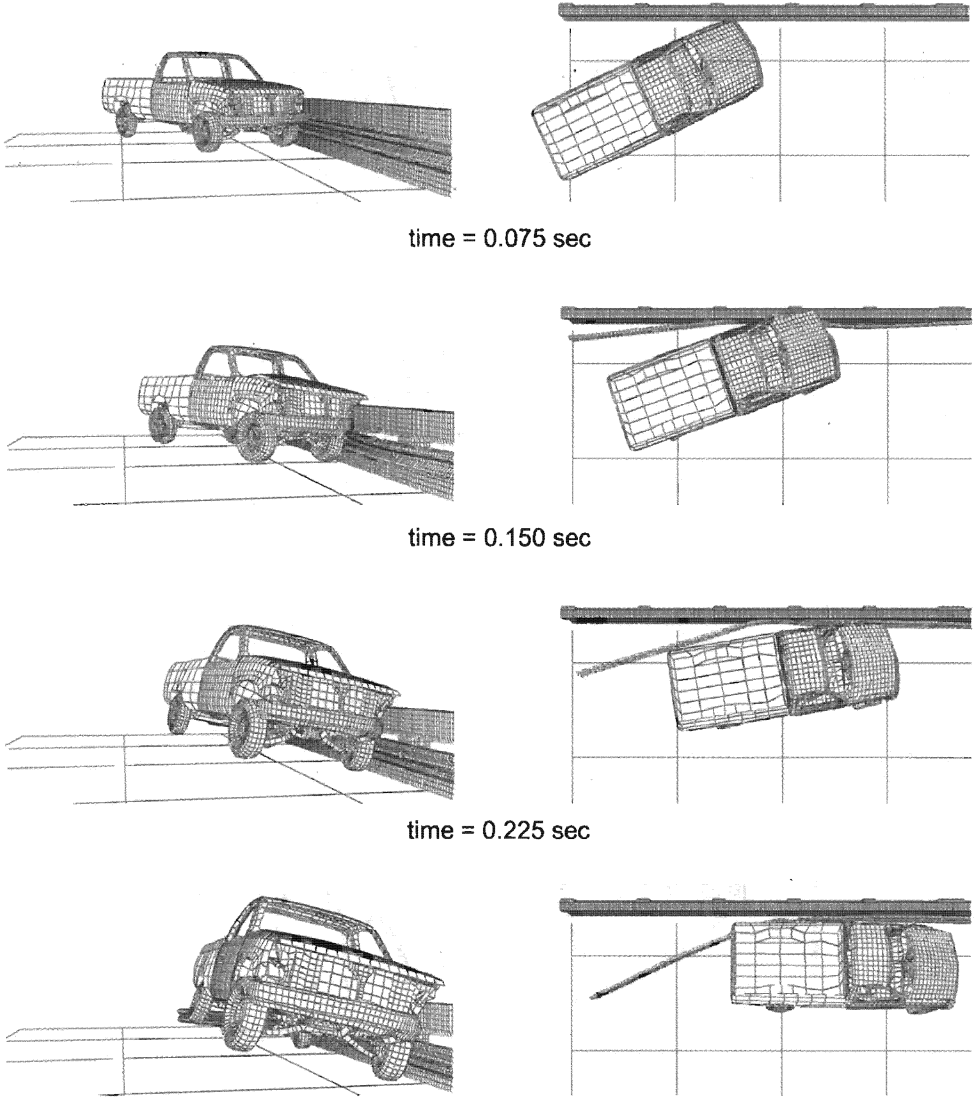
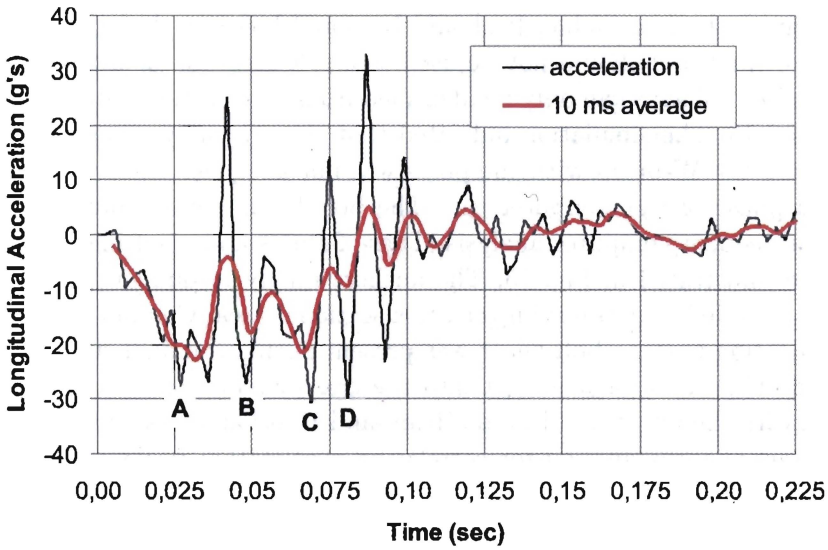
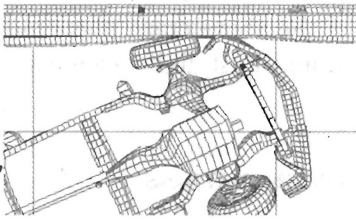

FIG. 15. Four time-frames of a crash simulation, test 6-4.



Point A - time $t = 0.027$ s



Point B - time $t = 0.048$ s

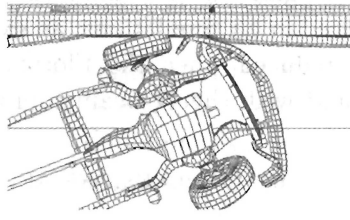

Point C - time $t = 0.069$ s

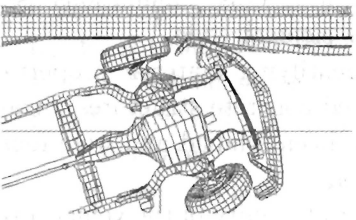

Point D - time $t = 0.081$ s

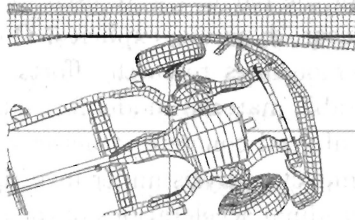

FIG. 16. Correlation of acceleration peaks A, B, C, and D (top) with crash events (bottom) at different time-frames for simulation 6-4.



Visual inspection of crash events for simulation 6-4 is offered in Fig. 15, which shows four time-frames: 0 ms, 75 ms, 150 ms, and 225 ms. Kinematics of the vehicle appears to be reasonable. It should be noted however that the sequential graphics cannot and should not be used as a sole identification of snagging problems. These problems can only be identified from acceleration data provided in Figs. 14 and 16. The simulation indicated that the originally assumed 8 mm bolt connecting the W-beam with the posts was not adequate and was sheared in the initial phase of the computer run. The bolt failures were correctly captured by a subsequent computer analysis. These failures and resulting guardrail separation are illustrated in Fig. 15. The authors finally recommended 16 mm bolts, which provided four times bigger cross sectional area. Computer run was repeated indicating that no bolt shear was present during the final simulation.

Figure 16 offers additional insight into the crash simulation of a Chevrolet pickup truck with the retrofitted Florida Beam-and-Post barrier (simulation 6-4). Frame-by-frame analysis allowed for correlating acceleration peaks (A through D, top of Fig. 16) with particular crash events as follows (note that the hood, the cabin and the box were “removed” from the bottom figures for clarity):

- Peak A: initial impact of the bumper against the W-beam,
- Peak B: pickup bumper impacting the W-beam backed by the post,
- Peak C: the wheel snags on the W-beam at the location of the post,
- Peak D: snagging between the pickup wheel and its frame.

As evidenced in all simulations, an extent of the above crash phenomena was substantially reduced when the Florida Beam-and-Post finite element models were augmented with the W-beam rubrail.

6. CONCLUSIONS AND RECOMMENDATIONS

The process of developing comprehensive finite element models of reinforced concrete Florida Beam-and-Post bridge barriers has been described in this paper. The models of the barriers were used for computer crash simulations using LS-DYNA nonlinear, dynamic, explicit 3-D finite element code.

The paper outlines research efforts in identifying material properties and the most suitable material model for reinforced concrete structures. Strain-rate effects for reinforced concrete structures have been studied and were found significant for impact analysis under investigation.

The longitudinal accelerations of the center of gravity of the vehicle exceeded the requirements of NCHRP Report 350 for all impact simulations. However, it should be noted that although NCHRP Report 350 requirements were closely followed, the results presented in this paper represent extreme conditions of a 2000 kg vehicle traveling at 100 km/hr and impacting a virtually rigid barrier at 25 degree angle.



The location of the initial point of impact is an area of special concern. NCHRP Report 350 provides specific guidelines for the determination of the "critical impact point." The vehicle can impact the barrier at any location yielding different results. Simulations not presented in this paper illustrated that the selection of the initial point of impact plays a very important role on the overall results obtained. It was found that the impact at the beam midpoint, between the posts often did not yield the most severe consequences.

In the late 1970's and early 1980's, full-scale crash tests were performed on several commonly used railings that had been designed under the static loading procedures. Several railings dramatically failed these tests, which clearly showed that the static design loading was not sufficient to ensure adequate railing performance. As a result of these tests, FHWA issued a policy (in 1986), which required full-scale crash tests for bridge barriers on federal aid projects. These barriers had to meet NCHRP Report 230 criteria or equivalent acceptance procedures. The report was superseded subsequently by NCHRP Report 350 in 1993.

Although the original, older barrier did not meet the requirements of the NCHRP Report 350, the barrier showed reliable structural response. All simulations with pickup truck indicated that the old barrier is strong and there is no need to replace it. However, a valuable retrofit design was proposed and evaluated for the existing FDOT Beam-and-Post reinforced concrete bridge railing. This proposed modification resulted in reduction of acceleration peaks by up to 50%.

Computer simulations indicated that an addition of the W-beam rubrail to the front of the posts facilitated a much smoother containment and redirection of the vehicle. The W steel beam should be installed between the top and bottom concrete beams, and should be bolted to the posts with two 5/8 in. (16 mm) diameter bolts. Another alternative to consider is the installation of a rectangular steel structural tubing ST 8 x 2 x 3/8" (ST 203 x 51 x 10 mm) between the top and bottom concrete beams and bolted to the posts with four 5/8 in. (16 mm) diameter bolts. The bolts should be embedded in the concrete post and one side of the structural tubing should be cut at the bolt locations to accommodate the bolts and to reduce snagging. It is expected that the performance level of the second retrofit idea will primarily depend on the section properties of the steel and the bolt diameter.

The numerous computer crash studies led to the development of some general guidelines to consider for the design and development of a modified reinforced concrete bridge barrier. While the Beam-and-Post concept is appealing for aesthetic purposes, problems arise in dealing with the contact between the vehicle and the post. Figure 17 illustrates the concept of what appears to be the most efficient use of this type of barrier. Efforts should be made to place the posts at the back of the barrier to avoid contact with oncoming vehicles. As shown

in Fig. 17, this concept is not new. It has been successfully implemented in guardrails, where longitudinal W-beam was the part designed to be in contact with an oncoming vehicle, while the post was moved back to reduce the risk of snagging. Practitioners generally agree that with the current reinforced concrete technology such a concept is feasible.

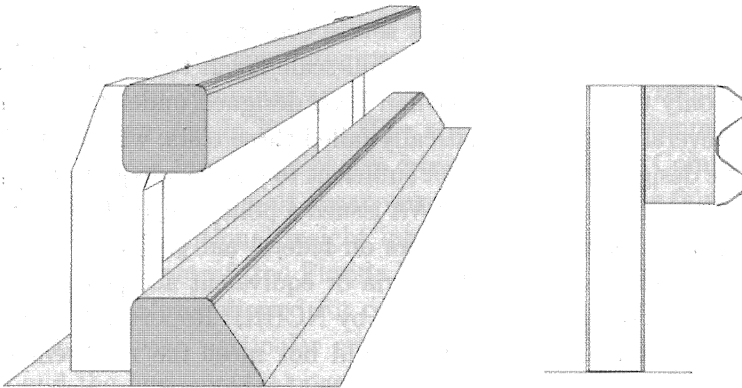

FIG. 17. A recommended concept of a new reinforced concrete bridge barrier. Left: a general, isometric view. Right: the concept of moving vertical posts away from oncoming vehicles has been successfully implemented in longitudinal guardrails.

The nature of the Finite Element Method is based on an approximation of the continuum with the discrete set of finite elements. The quality of results obtained generally improves with the increased density of the finite element mesh. Development of computer hardware in recent years offers hope that more detailed FEM models of the vehicles and the barriers will soon allow for improved, more detailed and more sophisticated finite element analyses.

Finite Element Method computer programs offer an attractive tool in the design and development of roadside safety features as well as in the evaluation of existing structures. This type of analysis can help to identify and correct the problems before they appear in practical applications.

ACKNOWLEDGEMENT

The research presented in this paper was supported by the Florida Department of Transportation through a research grant No. WPI-5010750. The opinions, findings and conclusions expressed in this paper are those of the authors and not necessarily those of the sponsor.

Computer time was provided in part by The Florida State University Super-computer Computational Research Institute on parallel processor equipment for



some computer runs. The authors also wish to thank Mr. Chris Gilbert for his assistance with modeling and computer runs.

Extensive research on full-scale crash tests of the existing concrete bridge barriers was made possible thanks to final reports provided by Mr. Roger Bligh (Texas Transportation Institute), and Drs. Ronald Faller and Dean Sicking from Midwest Roadside Safety Facility. Their comments and support are appreciated.

REFERENCES

1. American Association of State Highway and Transportation Officials (AASHTO), *Standard specification for highway bridges: interim specification - bridges*, 14th Edition, Washington, D.C., 1991.
2. A.Y. ABU-ODEH, R.P. BLIGH, H.E. ROSS, *Finite element analysis of a slip base luminaire support*, Conference Proceedings, Publication No. FHWA-RD-96-212, April, 113 - 128, 1997.
3. S.C.C. BATE, *The effect of impact loading on prestressed and ordinary reinforced concrete beams*, National Building Studies, Research Paper 35, Her Majesty's Stationery Office, London, 1961.
4. R.P. BLIGH, K.K. MAK, T.J. HIRSH, *Evaluation of tennessee bridge rail designs*, Texas Transportation Institute, Final Report No. TNRES1015, May, 140, 1994.
5. K. CICHOCKI, G. MAIER, U. PEREGO, *Analysis of damages due to underwater explosions on a hybrid structure*, International Journal for Engineering Analysis and Design, **1**, 341-361, 1994.
6. EAS Engineering, *Finite element model of 1982 Honda Civic*, A User Manual, August, 1993.
7. R.K. FALLER, J.C. HOLLOWAY, B.G. PFEIFER, B.T. ROSSON, *Performance level 1 tests on the Nebraska open concrete bridge rail*, Midwest Roadside Safety Facility, February, 105, 1992.
8. C.J. GILBERT, *Vehicle impact simulation utilizing computational finite element methods*, M.S. Thesis, Florida State University, Spring, 291, 1997.
9. J.O. HALLQUIST, *LS-DYNA3D theoretical manual*, LSTC Report 1018, Revision 3, April, 1994.
10. B.F. HENDRICKS, S.O. MARTIN, J.W. WEKEZER, *Impact simulation of the 820C vehicle with the G2 guardrail*, Conference Proceedings, Publication No. FHWA-RD-96-212, April, 129 - 147, 1997.
11. B.F. HENDRICKS, *Finite element modeling of the G2 guardrail*, Master of Science Thesis, Florida State University, Spring, 1996.
12. B.F. HENDRICKS, J.W. WEKEZER, *Finite element modeling of G2 guardrail*, Transportation Research Record 1528, Transportation Research Board, Washington, D.C., 1996.
13. T.J. HIRSCH, P. ROMERE, *Crash test of modified Texas C202 bridge rail*, Texas Transportation Institute, Report No. FHWA/TX-88/1179-1, June, 58, 1988.



14. T.J. HIRSCH, C.E. BUTH, W.L. CAMPISE, D. KADERKA, *Crash test of Texas T202 bridge rail*, Texas Transportation Institute, Report No. FHWA/TX-88/89/1179-2F, May, 48, 1989.
15. J.C. HOLLOWAY, R.K. FALLER, D.F. WOLFORD, D.L. DYE, D.L. SICKING, *Performance level 2 tests on a 29-in. Open concrete bridge rail*, Midwest Roadside Safety Facility, Final Report No. TRP-03-51-95, 87, June, 1996.
16. N. JONES, *Structural impact*, Cambridge University Press, 1989.
17. T. KRAUTHAMMER, A. ASSADI-LAMOUCI H. M. SHANAA, *Analysis of impulsively loaded reinforced concrete structural elements - II. Implementation*, Computers & Structures, 48, 5, 861-871, 1993.
18. LS-DYNA3D User's Manual, *Nonlinear dynamic analysis of structures in three dimensions*, Livermore Software Technology Corporation, August 1, Version 936, 1995.
19. J.D. MICHIE, *Roadside safety: areas of future focus*, TRB Workshop on Important Issues for Improving Roadside Safety, Conference Proceedings, Irvine, California, July 31 - August 2, 1995.
20. T. MUNZ, K. WILLAM, *Finite element modeling of vehicular collision with transformer base luminaire support*, Conference Proceedings, Publication No. FHWA-RD-96-212, 55 - 77, April, 1997.
21. C.A. PLAXICO, R.M. HACKETT, W. UDDIN, *Finite element simulation of vehicle impact against a modified three-beam guardrail*, Conference Proceedings, Publication No. FHWA-RD-96-212, 79 - 94, April, 1997.
22. C.A. PLAXICO, R.M. HACKETT, W. UDDIN, *Simulation of a vehicle impacting a modified three-beam guardrail*, Transportation Research Board, 76th Annual Meeting, Washington D.C., January 12-16, 1997.
23. G.H. POWELL, *Computer evaluation of automobile barrier systems*, Federal Highway Administration, Report No. FHWA-RD-73-73, August, 234, 1970.
24. M.H. RAY, K. HIRANMAYEE, *Quantitative evaluation of the fidelity of public-domain vehicle models*, International Journal of Crashworthiness, Woodhead Publishing Limited, Cambridge, 1999.
25. M.H. RAY, G.S. PATZNER, *A finite element model of the modified eccentric loader breakaway cable terminal (MELT)*, Conference Proceedings, Publication No. FHWA-RD-96-212, 33 - 53, April, 1997.
26. M.H. RAY, *The use of finite element analysis in roadside hardware design*, FHWA Workshop on Important Issues for Improving Roadside Safety, Irvine, CA, 1-13, July 31 - August 2, 1995.
27. J.D. REID, G.W. PAULSEN, *Design and simulation of large breakaway signs*, ASCE Journal of Transportation Engineering, 124, 1, Jan/Feb, 59 - 64, 1998.
28. J.D. REID, D.L. SICKING, R. BLIGH, *Critical impact point for longitudinal barriers*, ASCE Journal of Transportation Engineering, 124, 1, Jan/Feb, 65 - 72, 1998.
29. J.D. REID, *Simulation of four roadside safety applications*, Conference Proceedings, Publication No. FHWA-RD-96-212, 95 - 111, April, 1997.



30. H.E. ROSS, D.L. SICKING, R.A. ZIMMER, J.D. MICHIE, *Recommended procedures for the safety performance evaluation of highway features*, National Cooperative Highway Research Program Report 350, Transportation Research Board, Washington D.C., 1993.
31. D. SCHAUER, F. TOKARZ, G. KAY, A. LEE, R. LOGAN, E. COFFIE, M. RAY, *Preliminary vehicle impact simulation technology advancement (Pre-VISTA)*, Publication No. FHWA-RD-96-059, February, 135, 1997.
32. D. STOUT, J. HINCH, *Test and evaluation of traffic barriers: final report - technical*, ENSCO, Inc, Report No. FHWA-RD-89-119, April, 184, 1989.
33. J.W. WEKEZER, R. WUTTRICH, M. RAMALEY, *Performance problems and structural retrofit analysis of existing BCT terminals*, ASCE Journal of Performance of Constructed Facilities, August, 14, 3, 118-125, 2000.
34. J.W. WEKEZER, I. KREJA, C. GILBERT, *Conceptual analysis of an aesthetic bridge barrier*, Florida Department of Transportation, Final Report. Project No. WPI-5010750, July 30, 1997.
35. J.W. WEKEZER, *Finite element modelling of motor vehicles. Protocol for developing IN-GRID data input decks for DYNA3D computer code*, Technical Report No. FHWA-RD-94-153, U.S. Department of Transportation, FHWA, Washington, D.C., 1994.
36. J.W. WEKEZER, M.S. OSKARD, R.W. LOGAN, E. ZYWICZ, *Vehicle impact simulation*, Journal of Transportation Engineering, ASCE, 119, 4, July/August, 1993.
37. R.G. WHIRLEY, B.E. ENGELMANN, *DYNA3D, a nonlinear, explicit, threedimensional finite element code for solid and structural mechanics - user manual*, Lawrence Livermore National Laboratory, UCRLMA107254, November 1993.
38. A.K. ZAOUK, N.E. BEDEWI, C.D. KAN, D. MARZOUGUI, *Development and evaluation of a C-1500 pickup truck model for roadside hardware impact simulation*, Conference Proceedings, Publication No. FHWA-RD-96-212, 1 - 31, April, 1997.
39. A.K. ZAOUK, E. NABIH N.E. BEDEWI, C.D. KAN, H. SCHINKE, *Evaluation of a multi-purpose pick-up truck model using full scale crash data with application to highway barrier impacts*, 29th International Symposium on Automotive Technology and Automation, Florence, Italy, June, 1996.
40. A. ZAOUK, N.E. BEDEWI, C.D. KAN, D. MARZOUGUI, *Development and evaluation of a C-1500 pick-up truck model for roadside hardware impact*, presented in the FHWA Simulation Conference, Langley, VA, FHWA and GWU, July, 1996.
41. A. ZAOUK, N.E. BEDEWI, C.D. KAN, D. MARZOUGUI, *Validation of a non-linear finite element vehicle model using multiple impact data*, presented and published in the proceedings of the International ASME Winter Annual Congress and Exposition, Atlanta GA, November 17-22, ASME, 1996.

Received November 10, 2000; revised version June 9, 2001.

