

© 2019 IEEE. Personal use of this material is permitted. Permission from IEEE must be obtained for all other uses, in any current or future media, including reprinting/republishing this material for advertising or promotional purposes, creating new collective works, for resale or redistribution to servers or lists, or reuse of any copyrighted component of this work in other works.

RSS-based DoA Estimation for ESPAR Antennas Using Support Vector Machine

M. Tarkowski and L. Kulas, *Senior Member, IEEE*

Abstract—In this letter, it is shown how direction-of-arrival (DoA) estimation for electronically steerable parasitic array radiator (ESPAR) antennas, which are designed to be integrated within wireless sensor network (WSN) nodes, can be improved by applying support vector classification approach to received signal strength (RSS) values recorded at antenna's output port. The proposed method relies on ESPAR antenna's radiation patterns measured during the initial calibration phase of the DoA estimation process. These patterns are then used in support vector machine (SVM) training process adapted to handle ESPAR antenna-based DoA estimation. Measurements using a fabricated ESPAR antenna indicate that the proposed SVM approach provides more accurate results than available RSS-based estimation algorithms relying on power pattern cross-correlation (PPCC) method.

Index Terms—Switched-beam antenna, electronically steerable parasitic array radiator (ESPAR) antenna, direction-of-arrival (DoA), received signal strength (RSS), support vector machine (SVM), wireless sensor network (WSN).

I. INTRODUCTION

Electronically steerable parasitic array radiator (ESPAR) antennas [1]-[4], which are single output structures having only one active element surrounded by a number of passive elements connected to variable reactances, can successfully be used to estimate direction-of-arrival (DoA) of signals impinging the antenna from unknown directions in cost- and energy-efficient ways [5]-[10]. In contrast to the most popular approach involving antenna arrays with a number of digital signal processing (DSP) units, DoA estimation relying on ESPAR antennas require only one DSP-based radio-frequency (RF) receiver [5]-[8] or even a single inexpensive RF transceiver used in wireless sensor network (WSN) nodes [9], [10] connected to the antenna output port.

All methods proposed in the literature for DoA estimation in RF systems involving an ESPAR antenna use its capability of forming a directional radiation pattern by setting variable reactances to specific values. By changing these values electronically during continuous reception of a signal at the antenna output port, one will obtain signal samples recorded for different directions of the main beam, which can be then processed by one of the available DoA estimation algorithms, namely multiple signal classification (MUSIC) [5], [6],

estimation of signal parameters via rotational invariance techniques (ESPRIT) [7], and power pattern cross-correlation (PPCC) [8]-[10]. However, it has to be noted that MUSIC and ESPRIT algorithms require a DSP unit that gathers a considerable number of signal samples for every main beam direction [6], [7] and suffer from high computational cost [7], while PPCC method can provide more accurate results using a limited number of recorded received signal strength (RSS) values and a simple cross-correlation estimator [8]. In consequence, in measurements involving an ESPAR antenna having six parasitic elements connected to varactor diodes as variable reactances, it was possible to estimate DoA of a signal impinging the antenna with precision, which after [8] is the maximum absolute estimation error, equal to 2°, 3° and 7° using PPCC, MUSIC and ESPRIT methods respectively [5], [7], [8].

Because RSS-based DoA estimation together with beamforming capabilities can improve connectivity, coverage and energy efficiency in WSN applications [11], initially proposed ESPAR antenna [8], that requires applying correct bias voltages to varactor diodes using a DSP unit having six digital to analog converters (DAC), has been further adapted to work with WSN nodes based on simple and inexpensive transceivers able to measure RSS of incoming packets. To this end, an ESPAR antenna with twelve parasitic elements and simplified beam steering circuit, which relies on RF switches providing required load to the parasitic elements (close to open or short circuit), has been introduced [9]. However, such simplification have led to 4° maximum absolute estimation error when PPCC algorithm was used [10] in the similar conditions as those in [8].

In this letter, we propose to estimate DoA of a signal impinging the ESPAR antenna with twelve parasitic elements and simplified beam steering circuit by using support vector machine (SVM) technique, which so far has been used in DoA estimation involving linear [12] and planar [13] antenna arrays. This technique, which relies on well-established learning-by-examples paradigm (LBE), is backed up by solid mathematical foundation in statistical learning theory and can provide a good balance between accuracy and fast computations [14]-[17]. The proposed SVM-based DoA algorithm for ESPAR antennas relies on a LBE process involving radiation patterns of the antenna measured in an anechoic chamber and can easily be

This work was supported by SCOTT (www.scott-project.eu) project that has received funding from the Electronic Component Systems for European Leadership Joint Undertaking under grant agreement No 737422. This Joint Undertaking receives support from the European Union's Horizon 2020 research and innovation programme and Austria, Spain, Finland, Ireland, Swe-

den, Germany, Poland, Portugal, Netherlands, Belgium, Norway.

The authors are with the Department of Microwave and Antenna Engineering, Faculty of Electronics, Telecommunications and Informatics, Gdansk University of Technology, Narutowicza 11/12, 80-233 Gdansk, Poland (corresponding author: lukasz.kulas@pg.edu.pl).

integrated within inexpensive radio transceivers of WSN nodes equipped with ESPAR antennas. Measurement results indicate that the proposed approach increases the overall accuracy of RSS-based DoA estimation for ESPAR antennas.

II. RSS-BASED DOA ESTIMATION USING ESPAR ANTENNAS

The most effective and accurate way to estimate DoA of a signal impinging an ESPAR antenna, what can be concluded after a detailed analysis of the experiments available in [5], [7] and [8], is PPCC method originally proposed in [8]. This method relies on recorded RSS values at the antenna output port for different directions of the directional radiation pattern. Moreover, it can easily be implemented within a WSN node that is integrated with an ESPAR antenna [9], [10].

One of ESPAR antenna designs, which is presented in Fig. 1, has recently been proposed in [9] and [10] to provide beam steering and DoA estimation capability to a simple WSN node. The antenna has been optimized to work at 2.484 GHz and then fabricated using inexpensive FR4 laminate, in which top layer metallization is the antenna's ground plane. Because the digital single-pole, double-throw (SPDT) switches in Fig. 1 are connected to both parasitic elements' ends at the bottom layer of the structure and WSN node's microcontroller digital input output (DIO) ports, the antenna's radiation pattern can be shaped by setting a corresponding steering vector $V = [v_1, v_2, \dots, v_{12}]$ within the microcontroller as for $v_n = 0$ n -th parasitic element is connected to the ground and opened for $v_n = 1$. In consequence, using $V_{max}^1 = [1, 1, 1, 1, 1, 0, 0, 0, 0, 0, 0, 0]$ a directional main beam having 73.2° 3 dB beamwidth with the maximum at $\varphi_{max}^1 = 90^\circ$ (aligned with y axis) will be created [10] and, by applying a circular shift to V_{max}^1 , twelve different horizontal directions of the main beam, each shifted by 30°, can be produced [9], [10].

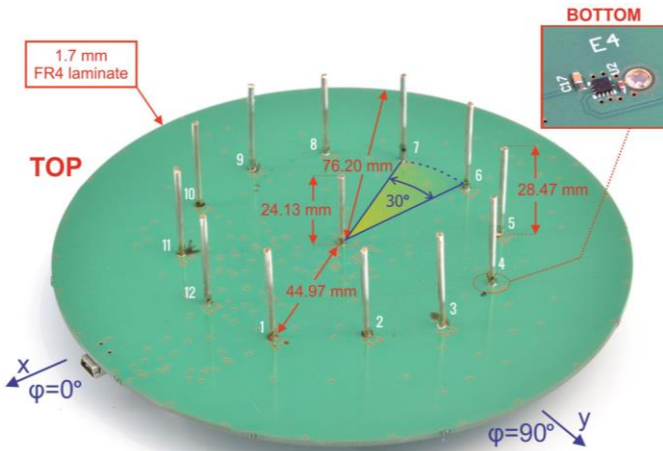

Fig. 1. An ESPAR antenna with simplified beam steering proposed in [10] for WSN nodes. The central element, fed by an SMA connector that can be connected to RF transceiver's output, is surrounded by parasitic elements, which ends are connected to SPDT switches (at the bottom layer of the structure) that can shorten individual elements to the ground or leave them open. Parasitic elements {6, 12} and {3, 9} are aligned with x and y axes respectively.

In order to perform DoA estimation based on recorded RSS values associated with received packets using PPCC method, one has to calculate cross-correlation coefficient $\Gamma(\varphi)$, originally proposed in [8], which, for the considered ESPAR antenna, can be written as [9]:

$$\Gamma(\varphi) = \frac{\sum_{n=1}^{12} (P(V_{max}^n, \varphi) Y(V_{max}^n))}{\sqrt{\sum_{n=1}^{12} P(V_{max}^n, \varphi)^2} \sqrt{\sum_{n=1}^{12} Y(V_{max}^n)^2}} \quad (1)$$

where $\{P(V_{max}^1, \varphi), P(V_{max}^2, \varphi), \dots, P(V_{max}^{12}, \varphi)\}$ are twelve ESPAR antenna's radiation patterns measured in the horizontal plane (i.e. $\theta = 90^\circ$) in an anechoic chamber for all corresponding steering vectors $\{V_{max}^1, V_{max}^2, \dots, V_{max}^{12}\}$ during a calibration phase, while $\{Y(V_{max}^1), Y(V_{max}^2), \dots, Y(V_{max}^{12})\}$ are RSS values recorded at the antenna output for the corresponding steering vectors during the actual DoA estimation process. It has been shown in [8], that the estimated DoA angle of a signal impinging the antenna $\hat{\varphi}$ is an angle φ associated with highest value of $\Gamma(\varphi)$.

III. PROPOSED DOA ESTIMATION USING SUPPORT VECTOR CLASSIFICATION

It has been introduced recently in [10], that because radiation patterns $P(V_{max}^n, \varphi)$ in (1) are measured in an anechoic chamber with certain angular step precision $\Delta\varphi$ before the DoA estimation, they can be represented as vectors $\mathbf{p}^n = [p_1^n, p_2^n, \dots, p_I^n]^T$, which values correspond to discretized angles φ that can be written as $\boldsymbol{\varphi} = [\varphi_1, \varphi_2, \dots, \varphi_I]^T$. In consequence, to implement (1) one can re-write it as:

$$\mathbf{g} = \frac{\sum_{n=1}^{12} (\mathbf{p}^n Y(V_{max}^n))}{\sqrt{\sum_{n=1}^{12} (\mathbf{p}^n \circ \mathbf{p}^n)} \sqrt{\sum_{n=1}^{12} Y(V_{max}^n)^2}} \quad (2)$$

where the symbol ' \circ ' stands for the Hadamard product, which is element-wise product of vectors, while $\mathbf{g} = [\Gamma(\varphi_1), \Gamma(\varphi_2), \dots, \Gamma(\varphi_I)]^T$ is a vector of length I containing discretized values of the correlation coefficient $\Gamma(\varphi)$ associated with the discretized values of φ in the vector $\boldsymbol{\varphi}$. As a result, by finding the highest value of \mathbf{g} and the corresponding value in the vector $\boldsymbol{\varphi}$ one will simultaneously determine the estimated DoA angle $\hat{\varphi}$.

As $\boldsymbol{\varphi}$ is a set of discretized angle values and $\hat{\varphi}$ belongs to the same set of values, the task described above in (2) can be seen as a classification problem with I classes. Power levels measured at every angle from within $\boldsymbol{\varphi}$ for all considered steering vectors $\{V_{max}^1, V_{max}^2, \dots, V_{max}^{12}\}$ can serve as a vector of $N = 12$ features for classification. Thus, the training data set to be used for classification [18] can be defined as $D = \{(\mathbf{p}_0, \varphi_0), (\mathbf{p}_1, \varphi_1), \dots, (\mathbf{p}_I, \varphi_I)\}$, in which 12 element vector $\mathbf{p}_i = [P(V_{max}^1, \varphi_i), P(V_{max}^2, \varphi_i), \dots, P(V_{max}^{12}, \varphi_i)]$ contains a set of all measured radiation pattern values at a particular angle φ_i .

Among many classification algorithms, Support Vector Machine (SVM) is one of the most popular and gained its popularity by large successes in image recognition and analysis with both accuracy and fast performance [16]. This approach derives from a maximal margin classifier and originally realizes linear, binary classification [19]. The main idea behind it is to



compute a hyperplane in N -dimensional space, where N equals to number of features, as a decision boundary, which leads to the following binary prediction [20]:

$$\hat{y} = \begin{cases} 0, & \text{when } \mathbf{w}^T \cdot \mathbf{x} + b < 0 \\ 1, & \text{when } \mathbf{w}^T \cdot \mathbf{x} + b \geq 0 \end{cases} \quad (3)$$

where \mathbf{w} is weight vector of length N produced as output in a SVM training process defining the hyperplane, b is a constant coefficient obtained in the same process and \mathbf{x} represents a vector of features. It is worth mentioning, that the decision boundary, defined by \mathbf{w} and b , is computed using soft-margin approach [20]. In consequence, the following constrained optimization problem has to be solved:

$$\underset{\mathbf{w}, b, \zeta}{\text{minimize}} \quad \frac{1}{2} \mathbf{w}^T \cdot \mathbf{w} + C \sum_{k=1}^K \zeta^{(k)} \quad (4)$$

subject to: $t^{(k)}(\mathbf{w}^T \cdot \mathbf{x}^{(k)} + b) \geq 1 - \zeta^{(k)}$ and $\zeta^{(k)} \geq 0$

where $\zeta^{(k)}$ is a slack variable measuring margin violation, C is a hyperparameter associated with soft-margin width, $t^{(k)} \in \{-1, 1\}$ defines classification instance and $k = 1, 2, \dots, K$ is a training sample number.

The considered DoA classification problem cannot be solved by the original SVM technique [19], [20], which deals with binary (i.e. two-class only) classification and relies on linear boundaries (3). In order to extend the number of classes to the required I , one has to use multiple binary SVMs with a specific scheme determining mutual decision boundaries. The “one-versus-rest” method allows to train I SVM classifiers, with I being the number of necessary classes, and treats each class as opposition to the rest. It means, that a recorded data sample belongs to the class, which scores the highest decision function [17]. Additionally, *kernel trick* technique [20], which allows for computationally effective transformation of vectors by using a special function called *kernel* [20], can be employed in order to use SVM in nonlinear DoA classification problems.

IV. MEASUREMENTS

In order to verify the overall accuracy of the SVM-based DoA estimation, we have performed measurements of the ESPAR antenna, shown in Fig. 1, in our $11.9 \times 5.6 \times 6.0$ m anechoic chamber in a setup presented in Fig. 2. As a first step, all twelve ESPAR antenna radiation patterns associated with twelve main beam directions were measured at 2.484 GHz with 1° angular step precision. These patterns have been then used as a training set in the learning process described in the previous section to obtain SVM-based DoA classification.

For SVM algorithm implementation, a library for support vector machines (LIBSVM) [21] and Scikit-Learn packet [22] were used. During the training process, which took only 1.78 s on Intel Core i7 2.6 GHz laptop, hyperparameter $C=1$ and Gaussian Radial Based function as the *kernel* function have been applied in order to achieve higher generalization in the DoA classification problem. Additionally, the “one-versus-rest” approach have been used to solve multiclass problem with the decision function of this scheme, which has been produced in the training process, shown in Fig. 3.

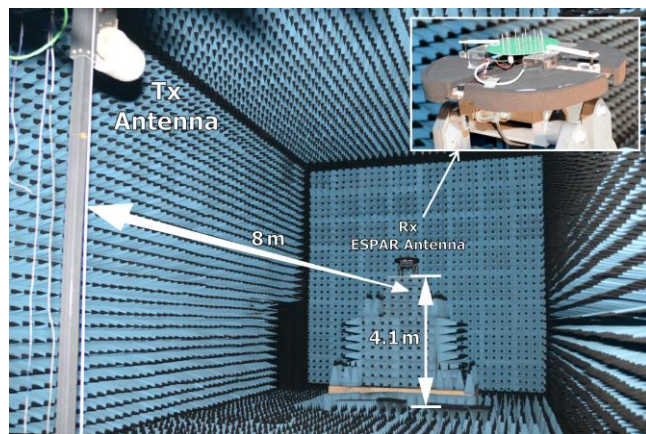

Fig. 2. The anechoic chamber, in which ESPAR antenna radiation patterns have been measured, together with a turntable with the installed antenna prototype.

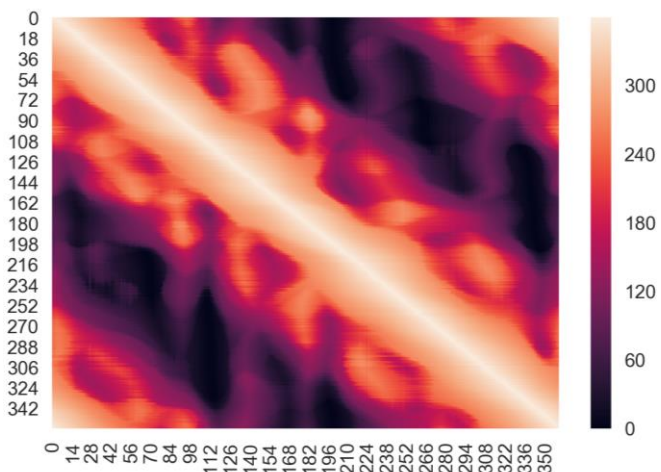

Fig. 3. The decision function in a matrix form of “one-versus-rest” multiclass SVM produced using measured ESPAR antenna radiation patterns for the proposed DoA estimation approach. The higher the value, the more probable match between classes, which in case of the proposed RSS-based approach corresponds to the angle of an unknown signal impinging the ESPAR antenna (see text for explanations).

During DoA estimation phase we have set up a test system presented in Fig. 4. To this end, a signal generator within NI PXIe-5840 Vector Signal Transceiver (VST) has been connected to a transmitting antenna placed in the anechoic chamber on a pole stand at $H = 4.1$ m to generate 10 dBm 2.484 GHz BPSK test signal, while the ESPAR antenna has been mounted on a turntable at the same height and 8.0 m from the transmitting antenna. The signal impinging the ESPAR antenna has been received by the same NI PXIe-5840 VST connected to ESPAR antenna’s output. Moreover, additive white Gaussian noise has been added to the received signal to generate a specific signal-to-noise ratio (SNR), so the results are more realistic and can easily be compared to those already available in the literature.

Directions of the signal impinging the ESPAR antenna were set by rotating the turntable in the horizontal plane with 5° angular step, hence providing 72 test directions. For every impinging signal’s direction, 10 snapshots were generated for each of the radiation patterns and, in consequence, twelve RSS output power values $\{Y(V_{max}^1), Y(V_{max}^2), \dots, Y(V_{max}^{12})\}$, which correspond to steering vectors $\{V_{max}^1, V_{max}^2, \dots, V_{max}^{12}\}$, has been recorded. The whole testing procedure took 33 min and 9.94 s.

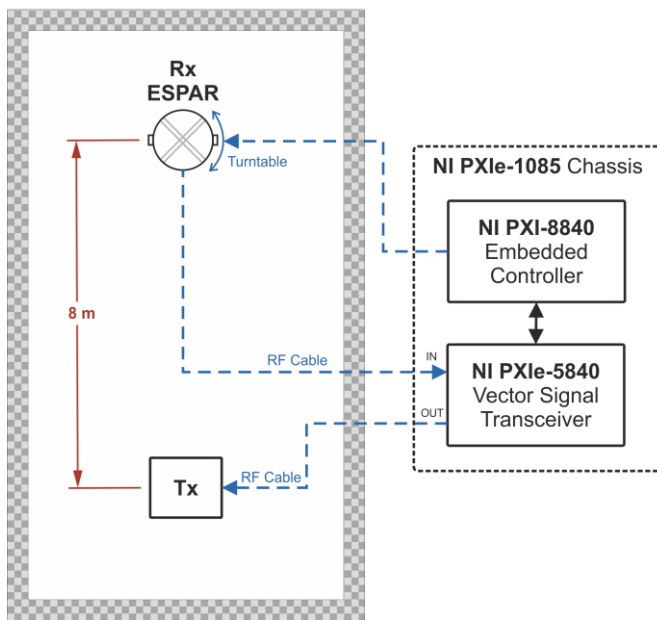

Fig. 4. Anechoic chamber test system used to determine DoA estimation errors (see text for explanations).

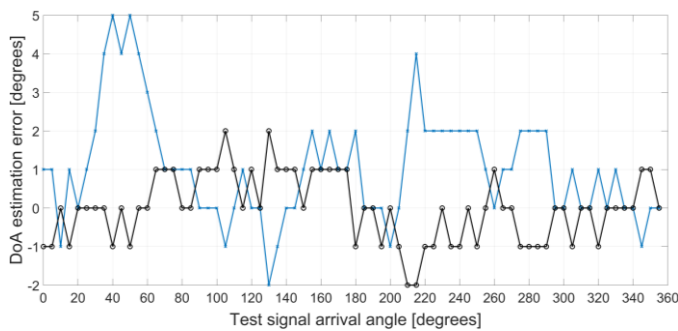

Fig. 5. DoA estimation errors obtained using PPCC algorithm (the thin blue line) and SVM technique (the thick black line with circle markers) from measurements at SNR = 20 dB.

TABLE I
COMPARISON OF DOA ESTIMATION ERRORS OBTAINED USING PPCC ALGORITHM AND SVM TECHNIQUE (SEE TEXT FOR EXPLANATIONS).

		SNR = 30 dB	SNR = 20 dB	SNR = 10 dB	SNR = 0 dB
PPCC	mean	1.11°	1.24°	1.42°	2.08°
	std	1.09°	1.24°	1.14°	1.55°
	rms	1.55°	1.74°	1.81°	2.59°
	precision	5°	5°	6°	7°
SVM	mean	0.54°	0.64°	0.65°	1.46°
	std	0.73°	0.87°	0.93°	1.86°
	rms	0.74°	0.87°	0.94°	1.87°
	precision	1°	2°	2°	6°

DoA estimation errors calculated using both PPCC algorithm and SVM technique are shown in Fig. 5. Additionally, to better compare the results, the estimation error mean, standard deviation, root-mean-square (RMS) error and precision, which after [8] is the maximum absolute estimation error, have been calculated from these 72 values and gathered in table I together with results obtained for three other SNR levels. It is clearly visible that the proposed SVM-based approach give much better DoA estimation results. In fact, for the ESPAR antenna

with simplified beam steering, it was possible to reach 0.67° estimation error mean and 2° precision level previously reported in [8] for the ESPAR antenna with beam steering relying on varactor diodes and DACs within a DSP unit. Because for SNR equal to 30, 20 and 10 dB the proposed method provide RMS levels that are halved when compared to PPCC algorithm and below 1°, the SVM-based DoA estimation can successfully be applied within WSN nodes equipped with ESPAR antennas not only to provide DoA estimation functionality to each node, but also to enable self-localization capability within a wireless sensor network operating in realistic scenarios [11].

One additional factor that should be considered is time required by both algorithms. Initial anechoic chamber calibration takes 33 min and 14.32 s. When PPCC algorithm is used this calibration time can easily be halved by using simple linear approximation of coarsely measured radiation patterns [10]. In case of SVM algorithm, in which the training requires only 1.78 s on Intel Core i7 2.6 GHz laptop but uses training sets being radiation patterns measured during the calibration procedure with fine 1° angular step precision, such time reduction cannot easily be implemented. As a consequence, to obtain good SVM-based classification, one has to provide accurate ESPAR radiation pattern measurements.

V. CONCLUSIONS

In this letter, it has been shown, how the overall accuracy of RSS-based DoA estimation using ESPAR antennas can be improved when support vector classification is applied. In the proposed approach, ESPAR antenna radiation patterns are measured in an anechoic chamber and then used as a training set in the learning process to obtain SVM algorithm for RSS-based DoA classification. Measurements indicate that the proposed method is much more accurate than PPCC-based DoA estimation algorithm and, for ESPAR antennas with simplified beam steering that can easily be integrated with inexpensive radio transceivers of WSN nodes, it allows to reach error levels reported previously only for the sophisticated beam steering solutions relying on varactor diodes controlled by DACs within a DSP unit. In consequence, the proposed SVM-based approach can successfully be used in WSN in order to provide not only DoA estimation functionality, but also self-localization capability within WSNs operating in noisy environments.

REFERENCES

- [1] R. Harrington, "Reactively controlled directive arrays," *IEEE Trans. Antennas Propag.*, vol. AP-26, no. 3, pp. 390-395, May 1978.
- [2] K. Gyoda and T. Ohira, "Design of electronically steerable passive array radiator (ESPAR) antennas," in *Proc. IEEE Antennas and Propagation Symp.*, vol. 2, Salt Lake City, UT, Jul. 2000, pp. 922-925.
- [3] R. Schlub and D. V. Thiel, "Switched parasitic antenna on a finite ground plane with conductive sleeve," *IEEE Trans. Antennas Propag.*, vol. 52, no. 5, pp. 1343-1347, May 2004.
- [4] M. Rzymowski, P. Woznica, and L. Kulas, "Single-Anchor Indoor Localization Using ESPAR Antenna," *IEEE Antennas Wireless Propag. Lett.*, vol. 15, pp. 1183-1186, 2016.
- [5] E. Taillefer, C. Plapous, J. Cheng, K. Iigusa, and T. Ohira, "Reactance-domain MUSIC for ESPAR antennas (experiment)," in *Proc. IEEE*



- Wireless Communications and Networking Conf.*, vol. 1, New Orleans, LA, Mar. 2003, pp. 98–102.
- [6] C. Plapous, Jun Cheng, E. Taillefer, A. Hirata and T. Ohira, "Reactance domain MUSIC algorithm for electronically steerable parasitic array radiator," in *IEEE Trans. Antennas Propag.*, vol. 52, no. 12, pp. 3257–3264, Dec. 2004.
- [7] E. Taillefer, A. Hirata and T. Ohira, "Reactance-domain ESPRIT algorithm for a hexagonally shaped seven-element ESPAR antenna," in *IEEE Trans. Antennas Propag.*, vol. 53, no. 11, pp. 3486–3495, Nov. 2005.
- [8] E. Taillefer, A. Hirata, and T. Ohira, "Direction-of-arrival estimation using radiation power pattern with an ESPAR antenna," *IEEE Trans. Antennas Propag.*, vol. 53, no. 2, pp. 678–684, Feb. 2005.
- [9] L. Kulas, "Direction-of-Arrival Estimation Using an ESPAR Antenna with Simplified Beam Steering", in *Proc. 47th Euro. Microw. Conf.*, Nuremberg, Germany, Oct. 2017, pp. 296–299.
- [10] L. Kulas, "RSS-based DoA Estimation Using ESPAR Antennas and Interpolated Radiation Patterns," *IEEE Antennas Wireless Propag. Lett.*, vol. 17, pp.25-28, 2018.
- [11] F. Viani, L. Lizzi, M. Donelli, D. Pregnotato, G. Oliveri, and A. Massa, "Exploitation of parasitic smart antennas in wireless sensor networks," *Journal of Electromagnetic Waves and Applications*, vol. 24, no. 7, pp. 993-1003, Jan. 2010.
- [12] M. Pastorino and A. Randazzo, "The SVM-based smart antenna for estimation of the directions of arrival of electromagnetic waves," *IEEE Trans. Instrum. Meas.*, vol. 55, pp. 1918–1925, Dec. 2006.
- [13] M. Donelli, F. Viani, P. Rocca, and A. Massa, "An innovative multiresolution approach for DOA estimation based on a support vector classification," *IEEE Trans. Antennas Propag.*, vol. 57, no. 8, pp. 2279–2292, Aug. 2009.
- [14] V. Vapnik, *Statistical Learning Theory*. New York: Wiley, 1998.
- [15] M. Martinez-Ramon and C. G. Christodoulou, *Support Vector Machines for Antenna Array Processing and Electromagnetics Synthesis Lectures on Computational Electromagnetics Lecture # 5*. San Rafael, CA: Morgan & Claypool, 2006.
- [16] F. Melgani and L. Bruzzone, "Classification of hyperspectral remote sensing images with support vector machines," in *IEEE Trans. Geosci. Remote Sens.*, vol. 42, no. 8, pp. 1778–1790, Aug. 2004.
- [17] C.-W. Hsu and C.-J. Lin, "A comparison of methods for multiclass support vector machines," in *IEEE Trans. on Neural Networks*, vol. 13, no. 2, pp. 415–425, March 2002.
- [18] K. Huang, H. Jiang and X. Zhang, "Field Support Vector Machines," in *IEEE Trans. Emerg. Topics Comput. Intell.*, vol. 1, no. 6, pp. 454–463, Dec. 2017.
- [19] B. E. Boser, I. M. Guyon, V. N. Vapnik, "A training algorithm for optimal margin classifiers", *Proc. 5th Annu. Workshop Comput. Learn. Theory*, pp. 144–152, 1992.
- [20] Aurelien Geron, *Hands-On Machine Learning with Scikit-Learn & TensorFlow*. Sebastopol, CA: O'Reilly Media, Inc., 2017, pp. 156–165
- [21] C. Chang and C. Lin, LIBSVM: a library for support vector machines, 2001.
- [22] F. Pedregosa et al., *Scikit-learn: Machine Learning in Python*, JMLR 12, pp. 2825–2830, 2011.

