

## SLIDING BURNISHING TECHNOLOGY OF HOLES IN HARDENED STEEL

Włodzimierz Przybylski

### Summary

New technology with sliding burnishing of holes with cylindrical surface, made of hardened steel (60 HRC), is presented in the paper. Burnishing process was applied with specially designed tools. These tools can be used in CNC lathes and machining centres. After burnishing operation on hole  $\varnothing$  30 mm in satellite gear wheel the surface roughness parameter  $R_a = 0,02-0,04 \mu\text{m}$  was obtained. The method and results of research as well as technological conclusions are presented.

**Keywords:** finishing process of holes, burnishing process, burnishing tools

### Technologia ślizgowego nagniatania otworów elementów maszyn ze stali hartowanej

#### Streszczenie

W artykule przedstawiono nową technologię otworów o gładkiej powierzchni, wykonanych w elementach maszyn ze stali hartowanej o twardości 60 HRC z zastosowaniem nagniatania ślizgowego. Obróbka wykończeniowa otworów odbywa się z użyciem specjalnych narzędzi nagniatających stosowanych na tokarkach CNC i centrach obróbkowych. Po nagniataniu otworu  $\varnothing$  30 mm w kole zębatym przekładni satelitarnej uzyskano powierzchnię o parametrze  $R_a = 0,02-0,04 \mu\text{m}$ . Podano przebieg i wyniki badań doświadczalnych oraz wnioski i zalecenia technologiczne.

**Słowa kluczowe:** obróbka wykończeniowa otworów, nagniatanie, narzędzia nagniatające

## 1. Introduction

Burnishing is a surface plastic forming method (Fig. 1) that can be done on turning machines as finishing method instead of traditional abrasive machining such as grinding or superfinish [1-3]. During burnishing (Fig. 1) chips, sparks [1-3] and dusts are not produced; also cooling agents are not needed opposite to abrasive machining. Therefore, burnishing is an ecological machining method and creates new possibility development as a method for forming specific and positive for operating parameters of surface layer of machine parts which are machined also after hardening [1, 4].

Using of burnishing tools on precision turning machines CNC and machining centres enable to concentrate forming and finishing operations on one machining

---

Address: Prof. Włodzimierz PRZYBYLSKI, Gdansk University of Technology, Faculty of Mechanical Engineering, Narutowicza st.11/12, 80-233 Gdansk, Poland, e-mail: wprzybyl@pg.gda.pl

station. In this case grinding is useless or can be done at another station, this help to reduce production costs [5-7].

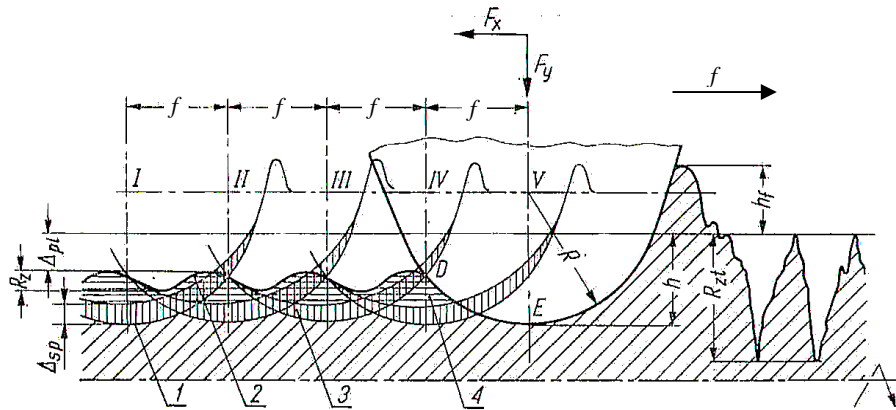

Fig. 1. Scheme of surface irregularities deformation by sliding burnishing: 1 – workpiece, 2 – part of burnishing diamond element:  $F$  – force,  $f$  – feed,  $\Delta pl$  – plastic deformation,  $\Delta sp$  – elastic deformation



Fig. 2. Sliding burnishing tools for lathes were designed and made by Gdansk University of Technology

More original researches and designing works for development of burnishing technology and its influence on operating parameters of machine parts have been made by Department of Manufacturing Engineering and Automation for many years. Researches concentrate on different types of burnishing [4, 8, 9]:

- rolling burnishing; rolling with disc, rolling with roller, balling,
- sliding burnishing of hardened parts [2] (elements with spherical cap) (Fig. 2),

- dynamic burnishing by balls (ball heads and balls' stream),
- oscillatory burnishing (rolling and sliding),
- simultaneous burnishing and turning (inside and outside surfaces),
- electromechanical burnishing.

There are also researches conducted for suitability and usability of different materials for burnishing tools. The following materials for tools were investigated:

- alloy steel after hardening (ex. ŁH 15),
- sintered carbides (rollers),
- technical ceramics (balls),
- natural and artificial diamonds (sliding elements),
- composites (ex. carbonado).

## 2. Burnishing of holes of toothed gear – satellites

Satellites of toothed gear are geared flywheel that unboundly rotates on cylinder surface of its pin. The inside surface of satellites' holes do not have splinways or grooves for internal retainer rings. Nowadays processing technology for holes is implemented:

- forming of material in the soft state (forging),
- heat treatment or thermochemical treatment (up to 60 HRC),
- after-machining grinding of hardened material.

Cylinder surface of satellites' hole enable to replace traditional after-machining grinding process with after-machining turning and sliding burnishing of hardened material. Both of these treatments/cuts can be fully operated and automated on one machine, for example CNC lathe.

The finishing turning of high hardened steel is nowadays possible because of new lucking types of cutting tools on the market.

Original sliding diamond tool [8] was designed and made by Department of Manufacturing Technology and Automation, Gdańsk University of Technology. This tool enables to start researches of burnishing process of cylindrical surfaces of holes. These researches were held for high hardened steel which was previously done with finishing method. The outside surface of tooth of satellite is the base for the finishing process of the hole in this technology like it's also for the grinding of the hole.

This new technology for satellites, made of steel 14 NiCrMo13-DIN, requires that the hole has to be done with one of these methods:

- drilling of material in soft state,
- heat treatment or thermo chemical treatment
- after-machining grinding of hardened material,
- sliding burnishing.

The cylindrical surface of the hole which is processed in this new technology, is processed at one machining station in just one fully automated operation that

contains two treatments. This way of processing gives cylindrical surfaces of holes with very low roughness of surface for which  $Ra < 0.2 \mu\text{m}$  and diameters in tolerance range (IT6÷IT7) can be obtained.

The researches were taken on the cylindrical surface of holes of satellites of toothed gears of motor vehicle (Fig. 3).

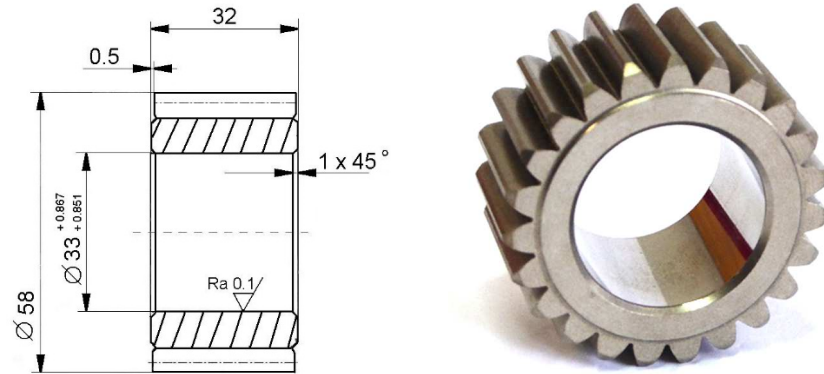

Fig. 3. Scheme of construction and view of satellite of planet gear

As a burnishing tool was used sliding tool with diamond element [7] which construction is showed on Fig. 4.

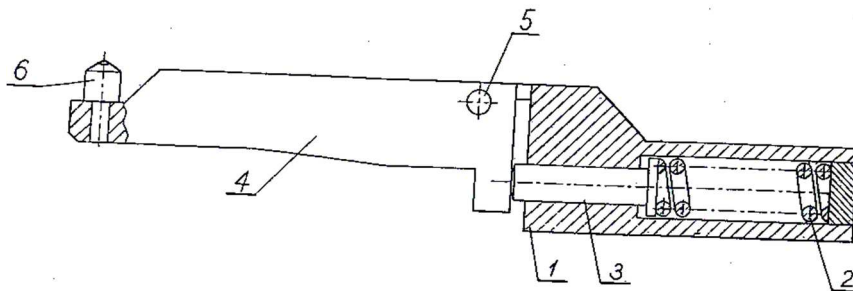

Fig. 4. Scheme of burnishing tool (Ntd 32) and its basic elements: 1- handle of tool with rolled cross section, 2 – coil spring, 3 – tapped, 4 – lever, 5 – axle, 6 – changeable diamond ball element with  $R = 1 \text{ mm}$

The burnishing tool was equipped with the exchangeable carbonado element [6] about the ray of the  $R = 1$  bowl mm (Fig. 5). The extended shape of the lever enables with processing of holes diameter greater than 30 mm and the maximum length of 130 mm. The tool is equipped with the tang part of  $\varnothing 32 \text{ mm}$  that is

enabling simple fastening in the standardized tool handle of the shield of the tool head of the CNC lathe.

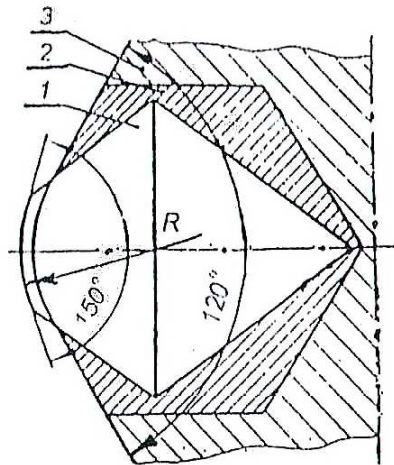

Fig. 5. Construction of changeable diamond ball element used in experiment:  
1 – ball-shaped “Carbonado”, 2 – silver solder, 3 – holder

### 3. Results of researches and their evaluation

Burnishing process was carried out on the CNC-N lathe TUR 50 provides with Sinumerik 810T controller (Fig. 7). The cooling and lubricating medium was supplied as a 4% aqueous solution of synthetic emulsifying oil for the turning and as a machine oils no 46 for the burnishing. Establishing and fastening the wheel of the satellite was being carried out in the self-centering three jaws handle, supplied into appropriately rolled soft jaws, through the indirect grip. This handle fixed satellites being based on surfaces of teeth. Satellites were made of the alloy steel being subject to processing thermo chemical treatment (for carbonizing and hardening).

Table 1. Hardness and roughness  $R_a$  of surface of satellite's hole after turning

| No | Medium value of hardness of surface [HRc] | Roughness $R_a$ after turning [ $\mu\text{m}$ ] |
|----|---|---|
| 1  | 60.7                                      | 0.15  |
| 2  | 61.2                                      | 0.18  |
| 3  | 60.5                                      | 0.19  |
| 4  | 60.8                                      | 0.22  |
| 5  | 62.3                                      | 0.21  |

Holes were being machined with the boring cutter with the fastened PcBN insert (cubic boron) nitride of the WIPER type made by SANDVIK, with signature WNGA 08 04 08 T01020AWH. Examining after machining of the surface of holes was carried out applying the following parameters of processing:

- cutting speed  $v_c = 120$  of m/min,
- feed  $f = 0,1$  the mm/turnover,
- depth of cutting  $a_p = 0,1$  mm.

Results of gated values of the parameter  $Ra$  are introduced in Table 1. The computer printout of the profile of the surface after boring is presented on Fig. 6.

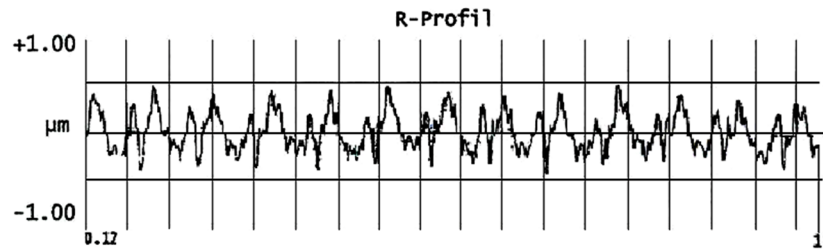

Fig. 6. Profilogram of surface of satellite hole after boring:  $v_c = 120$  m/min,  $f = 0.1$  mm/turn

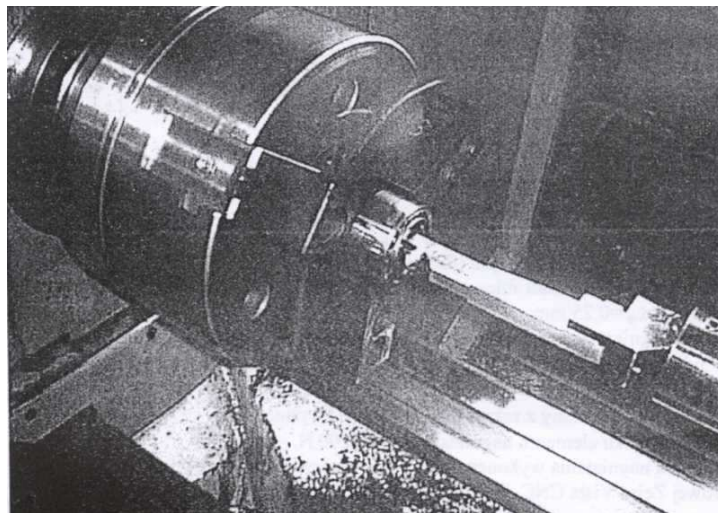

Fig. 7. Burnishing of satellite with burnishing tool Ntd 32

Examinations of burnishing the hole (Fig. 7) were carried out applying the following parameters:

- radius of the outline element  $R = 1\text{ mm}$  (Fig. 5),
- burnishing speed  $60\text{ m/min}$ ,
- feed changed in the range from  $0,02$  to  $0.06\text{ mm/turn}$ ,
- force of pressure of the burnishing element  $F = 200\text{ N}$ .

After burnishing measurements of holes' diameter were done with usage of coordinate measuring machine Zeiss Vista CNC. Results of holes diameter change after burnishing, arithmetic mean for 10 holes are included in Tab. 2.

Table 2. Measurement results for bored and burnished satellite's holes (mean of 10 tests)

| Diameter after boring<br>$d_t$ [mm] | Diameter after burnishing<br>$d_b$ [mm] | Diameter changes caused<br>by burnishing<br>$\Delta d$ [ $\mu\text{m}$ ] |
|-------------------------------------|---|--|
| 33.860                              | 33.866                                  | 6  |

Taken out scores were located within the tolerance of the hole which took out  $16\text{ }\mu\text{m}$ . Results of measurements of the roughness of the surface after burnishing were presented in Table 3.

Table 3. Technological parameters and burnishing results of satellite's hole ( $F = 200\text{ N}$ )

| No | $v_c$<br>[m/min] | $f$<br>[mm/turn] | $R_{at}$ after turning<br>[ $\mu\text{m}$ ] | $R_{an}$ after burnishing<br>[ $\mu\text{m}$ ] | $K_{Ra} =$<br>$= R_{an}/R_{at}$ |
|----|------------------|------------------|---|--|---------------------------------|
| 1  | 60               | 0.06             | 0.15  | 0.04   | 3.75                            |
| 2  | 60               | 0.05             | 0.17  | 0.04   | 4.25                            |
| 3  | 60               | 0.04             | 0.16  | 0.03   | 5.33                            |
| 4  | 60               | 0.03             | 0.17  | 0.02   | 8.5                             |
| 5  | 60               | 0.02             | 0.14  | 0.02   | 7                               |

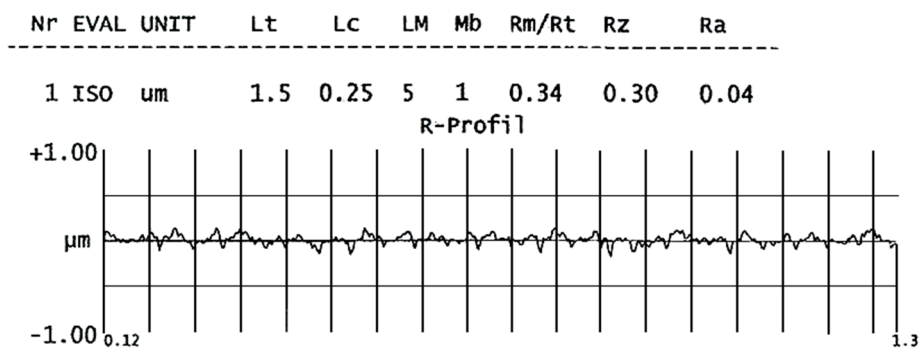

Fig. 8. Profilogram of surface of satellite's hole after burnishing:  $v_c = 60\text{ m/min}$ ,  $f = 0,06\text{ mm/turn}$ ,  $F = 200\text{ N}$

Getting out the value of the roughness parameter  $Ra$  of the surface after processing below  $0.1 \mu\text{m}$  was condition of the positive progress report for burnishing of the surface of holes as well as the presented new technology.

The computer exemplary printout of the profile of the surface after burnishing was printed on of Fig. 8.

#### 4. Conclusions

1. There is a possibility of making the cylindrical surface of holes in parts of hardened steel (60 HRC) by finishing method together with sliding burnishing. This enables to get holes in 6 ISO class of the accuracy and the roughness of the surface  $Ra \leq 0,1 \mu\text{m}$ .

2. The burnishing tool Ndt 32 enables to press the cylindrical surface of holes which diameter is greater than 30 mm. Indicator of reducing roughness of the surface of holes ( $K_{Ra}$ ) that has been previously machined is taking out from 3.75 to 7.00 for satellites of toothed gear transmissions with the hardened surface (60 HRC).

3. There is a possibility of connecting treatments i.e. of boring and burnishing into one operation carried out on the CNC lathe.

4. Applying sliding burnishing of holes in satellites it is possible to reduce the operating time with respect to the traditional grinding. Apart from that, practicing burnishing (that is chipless forming) is more ecological in the comparison to the grinding and it should a little more often be applied in the technology of elements of power unit.

#### References

- [1] W. GRZESIK, K. ZAK: Modification of surface finish produced by hard turning using superfinishing and burnishing operations. *Journal of Materials Processing Technology*, **26** (2012)1.
- [2] M. KORZYŃSKI: Nagniatanie ślizgowe. WNT, Warszawa 2007.
- [3] M. KORZYŃSKI, J. LUBAS, S. SWIRAD, K. DUDEK: Surface laser characteristics due to slide diamond burnishing with a cylindrical-ended tool. *Journal of Materials Processing Technology*, **211**(2011)1.
- [4] W. PRZYBYLSKI: Development and importance of burnishing technology in computer integrated manufacturing. Developments in Mechanical Engineering. Gdansk University of Technology Publishers. Gdańsk 2005.
- [5] J. KACZMAREK, W. PRZYBYLSKI: The surface contact characteristics after sliding and rolling burnishing. *Advances in Manufacturing Science and Technology*. **26**(2002)1.
- [6] W. PRZYBYLSKI: New ceramic and composite tools for smoothing burnishing process. *Fertigungstechnologien für die Automobilindustrie*. Polisch – Deutesch Seminar, IWF TU Berlin, Berlin 2005.





- [7] W. PRZYBYLSKI, M. SIEMIĄTKOWSKI: Creating manufacturing alternatives of axially symmetric parts incorporating burnishing technologies. Proc. of the 16<sup>th</sup> ICPR-16. Prague 2001.
- [8] W. PRZYBYLSKI, J. ZIELIŃSKI: Narzędzie do nagniatania ślizgowego wewnętrznych powierzchni walcowych. Wzór użytkowy W-112379, Warszawa 2003.
- [9] W. PSZIBYLSKI: Technologija powierhnostnoj plasticzeskoj obrabotki, Izdatielstwo Mietallurgija, Moskwa 1991 (in rus.).

*Received in August 2016*