

Received October 23, 2020, accepted December 6, 2020. Date of publication xxxx 00, 0000, date of current version xxxx 00, 0000.

Digital Object Identifier 10.1109/ACCESS.2020.3045633

Stress Monitoring System for Individuals With Autism Spectrum Disorders

MICHAŁ T. TOMCZAK¹, MAREK WÓJCIKOWSKI², BOGDAN PANKIEWICZ²,
JACEK ŁUBIŃSKI³, JAKUB MAJCHROWICZ⁴, DARIA MAJCHROWICZ⁵,
ANNA WALASIEWICZ⁶, TOMASZ KILIŃSKI⁷, AND MAŁGORZATA SZCZERSKA⁵

¹Department of Entrepreneurship, Faculty of Management and Economics, Gdańsk University of Technology, 80-233 Gdańsk, Poland

²Department of Microelectronic Systems, Faculty of Electronics, Telecommunications and Informatics, Gdańsk University of Technology, 80-233 Gdańsk, Poland

³Department of Machine Design and Vehicles, Faculty of Mechanical Engineering, Gdańsk University of Technology, 80-233 Gdańsk, Poland

⁴Epam Systems, Olivia Business Centre, 80-309 Gdańsk, Poland

⁵Department of Metrology and Optoelectronics, Faculty of Electronics, Telecommunications and Informatics, Gdańsk University of Technology, 80-233 Gdańsk, Poland

⁶Jan Twardowski School Complex No. 5 in Rypin, 87-500 Rypin, Poland

⁷District Sanitary and Epidemiological Station in Gdynia, 81-356 Gdynia, Poland

Corresponding authors: Michał T. Tomczak (michal.tomczak@pg.edu.pl) and Małgorzata Szczerska (malszcze@pg.edu.pl)

This work was supported in part by the National Centre for Research and Development, Poland (NCBiR), under Project 17/02/2018/UD, in part by the Gdańsk University of Technology, and in part by the DS Programs of Faculty of Electronics, Telecommunications and Informatics, Faculty of Mechanical Engineering, and Faculty of Management and Economics. The work of Michał T. Tomczak was supported by the National Science Centre, Poland (NCN), under Project 2019/03/X/HS4/00304.

ABSTRACT In this article, a stress monitoring system tailored for individuals with Autism Spectrum Disorders (ASD) and developed for the educational institution is presented. People with ASD face problems with effective stress management due to their high self-perceived levels of stress, poor ability to cope with it, and difficulties with the accurate detection of the source of stress. Consistently, being able to measure stress appears to be highly vital for this specific group. The design and construction of the measuring system are introduced. The stress monitoring system including autonomic wearable device (wristband), both the electronics and mechanical part, as well as the software application for data analysis are shown. The wearable device includes sensors for measuring heart rate, skin resistance, temperature and movement. A dedicated software application allows for generating reports to evaluate therapeutic effects. The complex stress monitoring system has been tested in an educational institution. It can provide significant support in the stress management of people with ASD and become a meaningful assistance in the therapy of neurodiverse individuals.

INDEX TERMS Assistive technology, autism spectrum disorders, electronic sensors, neurodiversity, stress management, stress monitoring.

I. INTRODUCTION

Stress is a significant factor affecting mental and physical health. It may lead not only to fatigue but also weaken our immune system [1]. Permanent stress can harm daily performance and entail health problems like depression, burnout or back pain [2]. It can be caused by various life events and stimuli as many possible stressors occur in daily activities. Some of them have a social background and relate to a variety of social interactions, e.g. communicating with other people, dealing with complicated tasks, group cooperation,

The associate editor coordinating the review of this manuscript and approving it for publication was Vishal Srivastava.

functioning under time pressure. Other stressors are associated with environmental influences such as temperature, humidity, sunlight exposure or noise [2]. According to the American Psychological Association [3], stress can be classified into acute stress, episodic acute stress, and chronic stress. Acute stress is short-term stress associated with daily demands, recent, past or near-future events. Episodic acute stress occurs when individuals suffer from repetitive stressful challenges and anticipate near danger. Chronic stress involves ongoing long-term worries that seem to occur permanently and is the most critical and harmful form of this phenomenon [1], [4]. Stress manifests itself in various physical, emotional and interpersonal symptoms [5]. There is no

doubt that early and accurate stress detection is an important issue in the context of its control, and a necessary condition for effective stress management interventions.

Stress management includes such activities as identification of stress and the use of prevention techniques for individuals to overcome stressors [6]. It can be defined as a psychoeducational program to cope with stress. Participants are trained to appraise the stressful events, develop effective skills and methods to deal with stressful situations, and learn how to use these skills in practice [7] (e.g. development of self-management skills, relaxation training, biofeedback, modification of behavior, cognitive behavioral therapy, social support, emotional expression, various forms of exercises and physical activity) [8]. As a response to an increase in stress level, these specific methods, procedures or activities are introduced to alleviate or eliminate the harmful effects of stress stimuli.

There is a group of neurodiverse people, namely individuals with Autism Spectrum Disorders (ASD), for whom the recognition and assessment of stressful situations can be a problem. It is for these individuals that the oppressive effect of stress is highly amplified. ASD are neurodevelopmental disorders comprising of numerous difficulties with social communication, social interaction, including social-emotional reciprocity, repetitive patterns of behavior, interests or activities and hyper- or hyporeactivity to sensory input [9], [10]. Individuals with ASD respond faster to fear [8], often experience high self-perceived stress levels [11], find it difficult to cope with stressful situations in everyday life [12], [13] and face difficulties with accurate stress detection [14]. As a result, for this stress-vulnerable group of individuals, stress monitoring and its effective management are even more important than for the general population [15].

The physiological measures of stress include skin conductivity, heart activity, brain activity and other primary physiological measures (such as blood pressure, blood volume pulse, electromyogram, skin temperature, and respiration) [16]. Many physiology-based stress detection systems use machine learning [17], [18], and are based on three main sensing types: wearable sensors, external sensors, and software sensing, where sensing data is obtained by software which does not necessarily require a dedicated hardware sensor [19].

The existing sensing technologies for screening and intervention tailored for individuals with ASD can be divided into electrodermal activity monitors, eye trackers, movement trackers, tactile sensors, vocal prosody and speech detectors, and sleep quality assessment devices [20]. In light of the existing empirical evidence, some studies have investigated the neural correlates of response and initiation, using an integrated EEG/eye-tracking system [21]. Studies further focused on an examination of the physiological response to and engagement during sociocognitive tasks conducted, using an electrocardiographic (ECG) signal-recording chest-belt [22], [23]. Further research

introduced a system of electronic sensors network measuring physiological parameters linked with emotional state changes to foster behavioral therapy [24]. There are also other solutions developed in order to improve therapeutic practices for individuals with ASD, based on Information Technology [25], [26]. Biofeedback devices for physiological parameters measurement developed for the general population are also available [27], e.g. commercially available “E4” wristband, including a photoplethysmograph for the heart rate, 3-axis accelerometer for movements, and optical infrared thermometer for detecting skin temperature [28]. However, they are not specifically tailored for the unique needs of people with ASD. As a result of sensory sensitiveness of individuals with ASD, the wearable device has to be “user friendly”, undisturbing when worn during daily activities and imperceptible in the sense of not triggering any discomfort to the user. To avoid the possibility of refusal or reluctance to use it, its design should be as ergonomic and discreet as possible [29].

In a situation, where individuals with ASD cannot cope with efficient stress management independently, the improvement can be achieved with the support of assistive technology [30], such as e.g. a holistic stress monitoring system. As mentioned above, although the existing literature focuses on the description of assistive technology for individuals with ASD [2], [20], [29], [31]–[35], there is still a lot to explore within this substantial field. In this article, a stress monitoring system for pupils in educational institutions was developed. The system was tailored for individuals with ASD.

II. MEASURING SYSTEM

The body’s response to psychological stress is the result of a number of neurohormonal changes. They depend on the activation of the hypothalamic-pituitary-adrenal axis, brainstem noradrenergic neurons, sympathetic adrenomedullary system, and parasympathetic system. The evolutionary goal of activating these systems is to adopt the body into a “fight or flight” situation. As a result, there are changes in several body functions, including among others:

- increased heart rate and cardiac output,
- increased blood pressure,
- skeletal muscle vasodilatation,
- cutaneous vasoconstriction,
- skin sweat glands and skin neuroendocrine system stimulation.

Some of the parameters mentioned above can be easily measured using available devices, e.g. heart rate or blood pressure. The measurement of others requires more unique devices that indirectly assess dermal vasoconstriction and secretion. Assuming that the cutaneous vasoconstriction should result in a decrease in the surface temperature of the skin, and changes in the secretory function of the skin should be reflected in its resistance, skin temperature and resistance sensors were used to evaluate these parameters. The starting point of these studies was to find the relationship between these parameters, which can be used as an

algorithm to identify the developing stress response of the body [36]–[39].

The stress monitoring system for individuals with developmental disorders consists of an autonomous wearable device and a software application that allows to manage data from sensors. The band includes sensors for measuring heart rate, skin resistance, temperature and movement. It detects stress situations using a specially designed algorithm for concurrent analysis and correlation of sensor data. The sensor bands are battery-powered, with a single charge running time of 20 hours. The wrist unit was designed from scratch to specifically suit the needs of children with developmental disorders. It is comprised of an electronic system with sensors, signal processing components and a battery power supply housed in a rigid protective case, equipped with an elastic wristband for comfortable and safe use. The system is dedicated to the observation and registration of the value of physiological parameters indicative of stress related reaction in individuals with developmental disorders.

A. AUTONOMIC WEARABLE DEVICE

1) ELECTRONICS PART

The prototype low power wearable device has been developed; equipped with plethysmographic (PPG) heart rate (HR) sensor BH1790GLC from ROHM Semiconductor, skin resistance sensor, accelerometer LSM6DSL from STMicroelectronics and a skin thermometer (infrared radiation sensor) MLX90615 from Melexis. The temperature sensor has 16-bit ADC accompanied with built-in DSP algorithms, that gives the resolution of 0.02°C , additionally the running-average has been used to provide better stability of readings.

The main part of the device is an embedded system build around a system-on-a-chip integrated circuit PSoC6 from Cypress, targeted to wearable devices containing dual-core CPU subsystem: 150 MHz Arm Cortex-M4F CPU with Floating-Point and Memory Protection Unit and a 100 MHz Cortex M0 + CPU. The digital part of the system also contains 1MB application Flash memory, 288KB of on-chip SRAM, I2C controller, UART, real-time clock, watchdog and timer. The PPG and temperature sensors have been connected using I2C bus, while the skin resistance sensor has been constructed using available on-chip analog and mixed-signal blocks: operational amplifier, transimpedance amplifier, analog multiplexers, A/D and D/A converters. The details regarding the auto-ranging skin resistance measurements have been published in our preliminary study [14], while the details regarding the heart rate measurement algorithm are presented in [40].

The system shown in Fig. 1 was physically realized on two separate PCBs, one of them including microcontroller, sensors, memory, and power supply control unit while second including inductive charger sub circuitry with connectors to a battery and mainboard. The mainboard is a 4-layer PCB with a total thickness of 0.41mm and a $20\text{mm} \times 30\text{mm}$ size. Two inner layers are used mainly as power supply, external layers are used for signals routing.

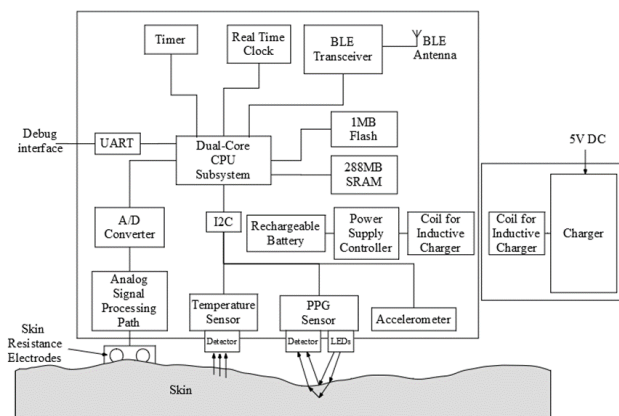

FIGURE 1. Block diagram of the sensor.

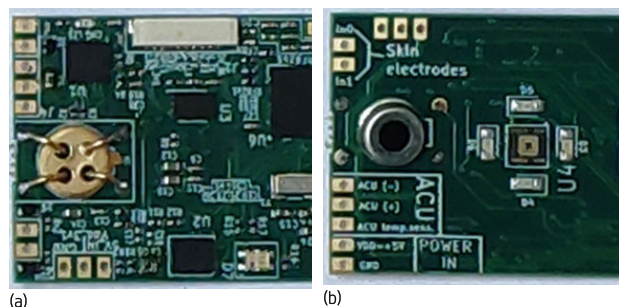

FIGURE 2. Photos of the fully assembled mainboard, (a) top side (b) bottom side.

The temperature sensor and PPG sensor are located at the bottom side of the PCB. This side is placed directly under the device's lid facing the skin of the person under examination. The inductive charger board is a 2-layer PCB of thickness 0.8mm and size $26\text{mm} \times 9.8\text{mm}$. As the power supply control unit, the STNS01 chip from STM was used. It includes both a low dropout linear voltage regulator for the system power supply as well as a single-cell charger unit with overcharge, over-discharge and over-current protection. The system is powered from a 65 mA Li-ion battery. The housing design can accept batteries of the capacity up to 110 mA. The main voltage was set to value equal to 3.1V which is 0.2V less than typical 3.3V. This reduces energy consumption (of about 12%) and enables the device to operate in a wider voltage range of the lithium-polymer battery. The battery is inductively charged. Fig. 2 shows photos of the fully assembled mainboard.

The measurements are stored in an on-chip flash-based database. The mainboard is equipped with a Bluetooth Low Energy (BLE) transmitter, which enables the transmission of measurements in real-time and export of the contents of the on-chip database to a Personal Computer (PC) system. The BLE transceiver built into the PSoC6 chip is used with the antenna made of copper layer on the PCB circuitry.

The main software, written in C programming language, is run on the Cortex M4 processor under a real-time operating system, while the second processor Cortex M0 + is mainly used to provide low power operation of the

BLE controller. Based on the short-term changes in the skin resistance, heart rate, and temperature, the software is responsible for reading all the sensors and estimating the excitation events of children. The device has sufficient processing power to locally analyze, filter and interpret live signals from the pulse detector and the accelerometer. Due to the local processing, which consumes less power than transmitting raw data, the device can operate in an autonomous mode. The device need not be on-line with base station all the time. It is sufficient to collect data for analysis, for example at the end of the day. Moreover, local processing gives the possibility to detect stress in real time, even at loss of when the radio link to base station is down.

2) MODEL FOR STRESS DETECTION

The algorithm of excitation calculation is based on a heuristic rule-based system with the following main assumptions, wherein case of stress:

1. a decrease in resistance is observed at Δt after a pulse increase,
2. temperature decrease is observed at Δt after a resistance decrease,
3. temperature reduction is observed at $2\Delta t$ after a pulse increase,

where Δt is an experimentally evaluated constant. The algorithm initialization is triggered by an accelerometric motion sensor at time t_i after the device is placed on the subject's hand. A system's start-up a procedure is run to obtain the reference levels P_{ref} , R_{ref} and T_{ref} for P (heart rate), R (skin resistance) and T (body temperature), respectively, which are calculated as the mean values over time t_a . Having calculated the initial reference levels, all the reference levels are continually updated when the measured value changes in a sustained manner for a longer period of time, according to the long-term change conditions presented in the middle column of Table 1.

Corrective factors a_P , a_R and the temperature difference threshold T_{th} are constant values determined experimentally.

The block diagram of an algorithm, common for the measured values of pulse, skin resistance and body temperature is shown in Fig. 3. The short-term and long-term conditions are specified in Table 1. Detection of the child's stress episode is based on the temporal differences between current measurements and the respective reference values. In case of stress situation, the algorithm from Fig. 3 generates events $E_P(t_{P0})$, $E_R(t_{R0})$, $E_T(t_{T0})$ for pulse, skin resistance and body temperature, respectively, and their respective start times t_{P0} , t_{R0} and t_{T0} . The start time of the event is defined as the time, when the beginning of the event occurred. An example of algorithm operation for pulse $P(t)$ is shown in Fig. 4, where at time $t = 160$ the event $E_P(t_{P0})$ is generated, which has been caused by two previous measurements that exceeded the allowed limits. Later, the calculation of a new reference level caused by multiple measurements exceeding the allowed limits, is started at $t = 210$.

Using the events $E_P(t_{P0})$, $E_R(t_{R0})$, $E_T(t_{T0})$ and their time differences, the stress level S can be calculated starting with

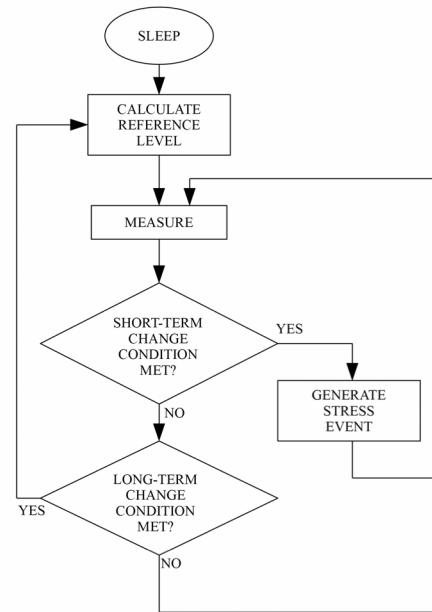

FIGURE 3. Diagram of the algorithm for generating events and initiating calculation of a new reference levels for the measured values: pulse, skin resistance and body temperature.

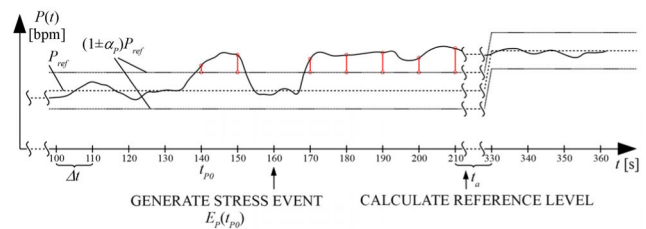

FIGURE 4. An example of algorithm operation for pulse measurement. The measurements are done every Δt . At time $t = 160$ the stress event $E_P(t_{P0})$ has been generated (short-term condition satisfied), where $t_{P0} = 140$. At $t = 210$ the procedure of calculating new reference level P_{ref} has been initiated (long-term condition satisfied).

the default value of $S = 0$ (no stress or baseline stress). When any of the conditions are met:

$$0 < t_{R0} - t_{P0} \leq \Delta t \text{ for event sequence } E_P(t_{P0}) \text{ and } E_R(t_{R0}) \tag{1}$$

$$0 < t_{T0} - t_{R0} \leq \Delta t \text{ for event sequence } E_R(t_{R0}) \text{ and } E_T(t_{T0}) \tag{2}$$

$$0 < t_{T0} - t_{P0} \leq 2\Delta t \text{ for event sequence } E_P(t_{P0}) \text{ and } E_T(t_{T0}) \tag{3}$$

then $S = S+1$ for each condition, so the value of $S = \{0, 1, 2, 3\}$. These calculations of S are made for overlapping events' times. The values of the parameters have been evaluated basing on the observations of the sensor readings on volunteers under various stress and no stress conditions. All the values are presented in Table 2 .

3) MECHANICAL PART

The device is comprised of a wristwatch-like protective case integrated into an elastic band (Fig. 5), maintaining the

TABLE 1. The Conditions for Long-Term and Short-Term Changes of the Measured Values Used in the Algorithm.

Measured value	Long-term condition (determining the execution of reference level re-calculation)	Short-term condition
Heart rate	$ P(t)-P_{ref} > a_p P_{ref}$ registered for a continuous period of time longer than t_p	$P(t)-P_{ref} > a_p P_{ref}$ registered exclusively for a continuous period of time t_p and not meeting this condition just before and shortly after this period
Skin resistance	$ R(t)-R_{ref} > a_R R_{ref}$ registered for a continuous period of time longer than t_R	$R_{ref}-R(t) > a_R R_{ref}$ registered exclusively for a continuous period of time t_R and not meeting this condition just before and shortly after this period
Body temperature	$ T(t)-T_{ref} > T_{th}$ registered for a continuous period of time longer than t_T	$T_{ref}-T(t) > T_{th}$ registered exclusively for a continuous period of time t_T and not meeting this condition just before and shortly after this period

TABLE 2. The Values of the Parameters Used in the Algorithm of Stress Level Calculation.

Parameter	Value	Unit
Δt	10	s
t_i	300	s
t_a	120	s
a_p	0.05	-
a_R	0.10	-
T_{th}	0.1	°C
t_p	30	s
t_R	60 s	s
t_T	60 s	s

contact of the sensors with the skin. A miniature, rigid housing has been manufactured for the electronic systems. Its shape was designed to fit into an opening in the elastic band to securely attach this module to the complete device. The electronic module contains an inductive (contactless) battery charging system, with the receiver coil located on the outer face of the module - farthest from the wrist.

B. APPLICATION FOR DATA ANALYSIS

The graphic module is the central part of the application that allows the presentation of the analyzed results. Data from the archiving module are displayed in a bar chart ('Add' and 'Remove selected' buttons in the 'Chart' section). Various time intervals can be set: a quarter of an hour, day, week,

**FIGURE 5. The wristband model containing electronic components and electrodes.**

month (dropdown under label 'Range'). The archiving module operations available to the user are divided into data management (buttons: 'Remove data' and 'Generate data'), downloading information about activation ('Connect band' button) and database management (buttons under 'Database' section). The information management module has 3 functions: entering information about a given child in the database ('Add' button), editing existing child data (corrections, data updates - 'Edit' button) and deleting child's data from the database ('Remove button'). The next functionality controls the download of data from the wearable device ('Connect band' button). The database management module allows to copy the entire database to any location, so the backup can easily be made or data can be forwarded to other users. It is also possible to import/load a previously saved database.

The data archiving module stores data used for presentation and analysis. All information is stored in a local database (H2 Database library standard). Thanks to this, quick browsing and selection of data can be performed with the use of standard programming tools. Furthermore, it is possible to develop the system towards an external database.

The key functionality of the application is the possibility of correlating the stress incident of two or more children in terms of simultaneous stimulation incidents. The tool's primary target use is to detect stress accidents which can be referred to external stressor sources in the environment around the monitored group of children. This, in turn, can help reduce the number of negative stimuli and improve the wellbeing of both the children and caretakers. The basis of the algorithm is the time window - the period of time - in which a joint response to some stimulus was determined. Another key element is the collection of notifications, ordered by chronology of their occurrence. The time window is passed over the set of notifications and checks if all the children are included in it. The time window probing scheme is shown in Fig. 6.

Technically, the time window is a queue. It is supplemented with notifications from the set according to chronology. Each time the size of the time window is tested. When the first and last notification times are too distant, the queue is reset to nil. Items are removed until the time window size does not exceed the limit. The next step is testing whether the time window contains notifications corresponding to all children.

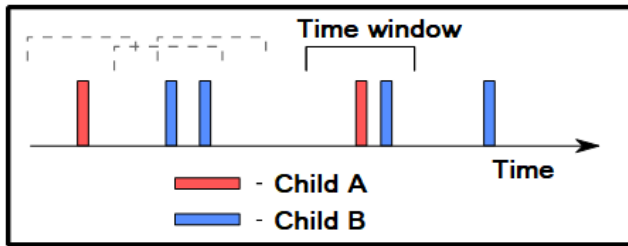

FIGURE 6. Time window probing scheme.

First, the number of notifications in the queue is checked, if it is smaller than the number of children involved, then the whole process is restarted. Another notification is added to the queue until the notification set is exhausted. However, if the number of notifications is the same or greater as the number of children, the content of the entire queue is checked. When there are notifications for all the children, a correlated notification is added, the queue is cleared and the process restarts again.

III. RESULTS

To verify the correct operation of the stress control system, field tests were performed on a group of 20 people diagnosed with Autism Spectrum Disorders (19 males and 1 female), within 4 groups of 5 individuals each. The study group included 12 children, 6 adolescents and 2 adults, and all were under the care of a special school. Table 3 contains basic data about study participants, the duration of wearing the wristband, and their reactions. All individuals who participated in the study have developmental disorders to varying degrees. Therapists explained to the students what a wristband was and what was the reason to put it on. However, not all participants understood the purpose of wearing the device, which was caused by their deficits and developmental disorders. The span of a single test was predefined as a 5-hour session of continued use (a typical school day). To conduct a comparison with system indications, each stress level increase detection was also confirmed by the therapist during the observation, who registered a stress situation whether it has occurred in the examined group. Each decision to classify a certain situation occurred as stressful was based on such symptoms as children’s behavior, gesture, interaction, voice, and facial features [16]. At the end of a test session, data from the 20 wristbands in testing were downloaded to a PC hub.

The observed simultaneous stress incident was linked to the events of the test period. The wearable devices have successfully passed operational tests. One case of breaking the wristband by a child was found at the time of very strong emotional arousal. The safety feature of the elastic band was thus confirmed, as one of the corrugated tape linkages snapped without any harm to the user, while the integrity of the electronic module and resistance sensor holder were preserved. The replacement of the elastic band is a relatively easy procedure, so the unit could be repaired overnight for continued use during the day. User tests confirmed the correct elasticity of the retaining bands, which needed to be

TABLE 3. Basic Data About Study Participants, the Time of Wearing the Wristband and Their Reactions.

No.	Gender	Age	Wearing time	Reactions to wear the wrist band
1	Male	5	5h	positive
2	Male	5	1 min	negative
3	Male	5	5h	positive
4	Male	6	5h	positive
5	Male	6	4.5h	positive
6	Male	6	4h	positive
7	Male	7	2 min	negative
8	Male	7	10 min	negative
9	Male	8	3h	positive
10	Male	8	5h	positive
11	Male	9	5h	positive
12	Male	10	5h	positive
13	Male	13	5h	positive
14	Female	13	5h	positive
15	Male	14	2h	positive
16	Male	15	5h	positive
17	Male	16	5h	positive
18	Male	17	5h	positive
19	Male	22	5h	positive
20	Male	24	5h	positive

balanced to fulfill two opposing criteria: ease of use (sliding on and off the wrist, comfort in prolonged wearing) and sufficient compressive pressure being applied to the skin resistance measurement electrodes.

Efforts of many research groups have focused on the elaboration system which can improve both the everyday life routine as well as the therapy of individuals with ASD. There are various systems supporting the therapy of individuals with ASD reported in the literature, including solutions applying robots [41], [35], the application of computer vision to monitor the behavior [42], or the use of computer technologies for automatic recognition of the therapy’s progress [43]. However, none of these systems is capable of relaying information about the real-time stress situation. Moreover, the usefulness of commercially available stress recognition systems by i.a. ThoughtStream, StressEraser, or mWave, is limited, because they are complex, not user friendly, and usually require the user to remain seated for a certain period of time, which is a serious impediment, and a barrier in usage with neurodiverse individuals.

A stress monitoring system presented allows to reliably record stress situation based on the readouts from several sensors, and make notification to the therapists easier, which ultimately improves the effectiveness of the therapy itself. Furthermore, the system also gives the possibility to analyze the stress incidents and to make comparisons between individuals and over period of time. The wearable device is flexible, comfortable, and easy to use every day. The system, according to the best knowledge of authors, is the first one that gives such a range of possibilities, so both, the therapy as well as the everyday life of individuals with ASD can be improved, which distinguishes the system from other known solutions.

MOST WIEDZY Downloaded from mostwiedzy.pl

IV. CONCLUSION

A complex stress monitoring system consisting of the autonomic wearable device and data analysis software environment allows not only to observe and record stress level increase incidents in children with Autism Spectrum Disorders but also to generate reports to help evaluate therapeutic effects based on quantifiable information. It enables (while maintaining proper metrological parameters) accurate measurement of the physiological parameters, such as heart rate, skin resistance and temperature, the values of which change when a stressful situation occurs. The system exhibited a satisfactory capability for self - calibration to the physiological bias of various individuals (different base heart rate, local temperature and electrical resistance of the skin). The use of current design and manufacturing technologies: 3D printing technology and vacuum forming from liquid phase polymers, allow for low-cost manufacturing of sensory units in scalable numbers, ranging from small series up to mass production. Thanks to the modular design the wristband can easily be modified to satisfy customized requirements such as external appearance, elasticity, color, size or a different method of attachment to the user's wrist. It is also possible to easily facilitate different functionality in the electronic module to expand or change the potential target user group.

The correct functioning of the system was verified and successful detection of stress in a group of individuals was confirmed. The operational tests of the wristband were performed on a group of users, as well as data transfer and analysis using the dedicated software application. A positive correlation was observed between stress incidents and the events within the test environment wherein the test group was interacting. According to the analysis of the teachers' observations and the readouts from the system, it reacted properly and registered the stress in children at precisely the moment when the actual stress event was observed and reported by the supervising staff.

Therefore, we believe that the system can provide significant support in the stress management of people with ASD and become a meaningful assistance in the therapy of these individuals conducted in educational institutions. The usefulness of the system was also evaluated and approved by professional caretaking personnel working on a daily basis with individuals with ASD.

REFERENCES

- [1] S. Elzeiny and M. Qaraqe, "Blueprint to workplace stress detection approaches," in *Proc. Int. Conf. Comput. Appl. (ICCA)*, Beirut, Lebanon, Aug. 2018, pp. 407–412.
- [2] M. Fellmann, F. Lambusch, and L. Pieper, "Towards combining automatic measurements with self-assessments for personal stress management," in *Proc. IEEE 21st Conf. Bus. Informat. (CBI)*, Moscow, Russia, vol. 1, Jul. 2019, pp. 604–611.
- [3] *American Psychological Association*. Accessed: Mar. 20, 2020. [Online]. Available: <https://www.apa.org/topics/stress>
- [4] *Australian Psychological Society*. Accessed: Mar. 20, 2020. [Online]. Available: <https://www.psychology.org.au/for-the-public/psychology-topics/stress>
- [5] J. Roszler and M. Brail, "Stress management," *AADE Pract.*, vol. 5, no. 3, pp. 34–37, 2017.
- [6] S. T. Surulivel, R. Alamelu, and S. Selvabaskar, "A study on workplace stress and its management—A structural equation model (SEM) approach," in *Proc. Int. Conf. Sci. Eng. Manage. Res. (ICSEMR)*, Chennai, India, 2014, pp. 1–5.
- [7] S. E. Taylor, *Health Psychology*. New York, NY, USA: McGraw-Hill, 2006.
- [8] P. M. Lehrer, R. L. Woolfolk, and W. E. Sime, Eds., *Principles and Practice of Stress Management*. New York, NY, USA: Guilford Press, 2007.
- [9] E. Nagy, S. C. Paton, F. E. A. Primrose, T. N. Farkas, and C. F. Pow, "Speeded recognition of fear and surprise in autism," *Perception*, vol. 47, no. 12, pp. 1117–1138, Dec. 2018.
- [10] *Diagnostic and Statistical Manual of Mental Disorders DSM-5*, 5th ed., Amer. Psychiatric Assoc., Amer. Psychiatric Publishing, Washington, DC, USA, 2013.
- [11] L. Bishop-Fitzpatrick, N. J. Minshew, C. A. Mazefsky, and S. M. Eack, "Perception of life as stressful, not biological response to stress, is associated with greater social disability in adults with autism spectrum disorder," *J. Autism Develop. Disorders*, vol. 47, no. 1, pp. 1–16, Jan. 2017.
- [12] T. Hirvikoski and M. Blomqvist, "High self-perceived stress and poor coping in intellectually able adults with autism spectrum disorder," *Autism*, vol. 19, no. 6, pp. 752–757, Aug. 2015.
- [13] M. G. Baron, J. Groden, L. P. Lipsitt, and G. Groden, Eds., *Stress and Coping in Autism*. Oxford, U.K.: Oxford Univ. Press, 2006.
- [14] M. T. Tomczak, M. Wójcikowski, P. Listewnik, B. Pankiewicz, D. Majchrowicz, and M. Jędrzejewska-Szczerska, "Support for employees with ASD in the workplace using a Bluetooth skin resistance sensor—A preliminary study," *Sensors*, vol. 18, no. 10, p. 3530, Oct. 2018.
- [15] C. Hufnagel, P. Chambres, P. R. Bertrand, and F. Duthiel, "The need for objective measures of stress in autism," *Frontiers Psychol.*, vol. 8, p. 64, Jan. 2017.
- [16] N. Sharma and T. Gedeon, "Objective measures, sensors and computational techniques for stress recognition and classification: A survey," *Comput. Methods Programs Biomed.*, vol. 108, no. 3, pp. 1287–1301, Dec. 2012.
- [17] S. S. Panicker and P. Gayathri, "A survey of machine learning techniques in physiology based mental stress detection systems," *Biocybernetics Biomed. Eng.*, vol. 39, no. 2, pp. 269–444, 2019.
- [18] A. R. Subhani, W. Mumtaz, M. N. B. M. Saad, N. Kamel, and A. S. Malik, "Machine learning framework for the detection of mental stress at multiple levels," *IEEE Access*, vol. 5, pp. 13545–13556, 2017.
- [19] E. Garcia-Ceja, M. Riegler, T. Nordgreen, P. Jakobsen, K. J. Oedegaard, and J. Tørresen, "Mental health monitoring with multimodal sensing and machine learning: A survey," *Pervas. Mobile Comput.*, vol. 51, pp. 1–26, Dec. 2018.
- [20] J.-J. Cabibihan, H. Javed, M. Aldosari, T. Frazier, and H. Elbashir, "Sensing technologies for autism spectrum disorder screening and intervention," *Sensors*, vol. 17, no. 12, p. 46, Dec. 2016.
- [21] L. Billeci, A. Narzisi, A. Tonacci, B. Sbriscia-Fioretti, L. Serasini, F. Fulceri, F. Apicella, F. Sicca, S. Calderoni, and F. Muratori, "An integrated EEG and eye-tracking approach for the study of responding and initiating joint attention in autism spectrum disorders," *Sci. Rep.*, vol. 7, no. 1, pp. 1–13, Dec. 2017.
- [22] S. Di Palma, A. Tonacci, A. Narzisi, C. Domenici, G. Pioggia, F. Muratori, and L. Billeci, "Monitoring of autonomic response to sociocognitive tasks during treatment in children with autism spectrum disorders by wearable technologies: A feasibility study," *Comput. Biol. Med.*, vol. 85, pp. 143–152, Jun. 2017.
- [23] L. Billeci, A. Tonacci, A. Narzisi, Z. Manigrasso, M. Varanini, F. Fulceri, C. Lattarulo, S. Calderoni, and F. Muratori, "Heart rate variability during a joint attention task in toddlers with autism spectrum disorders," *Frontiers Physiol.*, vol. 9, p. 467, May 2018.
- [24] M. Jędrzejewska-Szczerska, K. Karpieńko, and A. Landowska, "System supporting behavioral therapy for children with autism," *J. Innov. Opt. Health Sci.*, vol. 8, no. 3, 2015, Art. no. 1541008.
- [25] A. Kołakowska, A. Landowska, A. Anzulewicz, and K. Sobota, "Automatic recognition of therapy progress among children with autism," *Sci. Rep.*, vol. 7, no. 1, Dec. 2017, Art. no. 13863.
- [26] A. Kołakowska, A. Landowska, M. R. Wróbel, D. Zaremba, D. Czajak, and A. Anzulewicz, "Applications for investigating therapy progress of autistic children," *Ann. Comput. Sci. Inf. Syst.*, vol. 8, pp. 1693–1697, Sep. 2016.
- [27] U. Zalabarria, E. Irigoyen, R. Martinez, M. Larrea, and A. Salazar-Ramirez, "A low-cost, portable solution for stress and relaxation estimation based on a real-time fuzzy algorithm," *IEEE Access*, vol. 8, pp. 74118–74128, 2020.

- [28] C. McCarthy, N. Pradhan, C. Redpath, and A. Adler, "Validation of the empatica e4 wristband," in *Proc. IEEE EMBS Int. Student Conf. (ISC)*, Ottawa, ON, Canada, May 2016, pp. 1–4.
- [29] M. T. Tomczak, "Employees with autism spectrum disorders in the digitized work environment: Perspectives for the future," *J. Disab. Policy Stud.*, pp. 1–11, 2020, doi: 10.1177/1044207320919945.
- [30] L. J. Wali and F. Sanfilippo, "A review of the state-of-the-art of assistive technology for people with ASD in the workplace and in everyday life," in *Digital Transformation for a Sustainable Society in the 21st Century (Lecture Notes in Computer Science)*, vol. 11701, I. Pappas, P. Mikalef, Y. Dwivedi, L. Jaccheri, I. Krogstie, and M. Mäntymäki, Eds. Cham, Switzerland: Springer, 2019, pp. 520–532.
- [31] J. C. Epifanio and L. F. Da Silva, "Scrutinizing reviews on computer science technologies for autism: Issues and challenges," *IEEE Access*, vol. 8, pp. 32802–32815, 2020.
- [32] M. Jędrzejewska-Szczerska, K. Karpienko, and A. Landowska, "System supporting behavioral therapy for children with autism," *J. Innov. Opt. Health Sci.*, vol. 8, no. 3, pp. 1–8, 2015.
- [33] A. Kołakowska, A. Landowska, A. Anzulewicz, and K. Sobota, "Automatic recognition of therapy progress among children with autism," *Sci. Rep.*, vol. 7, no. 1, pp. 1–14, Dec. 2017.
- [34] F. Sanfilippo and K. Raja, "A multi-sensor system for enhancing situational awareness and stress management for people with ASD in the workplace and in everyday life," in *Proc. 52nd Hawaii Int. Conf. Syst. Sci.*, Maui, HI, USA, 2019, pp. 4079–4086.
- [35] S. Ali, F. Mehmood, D. Dancey, Y. Ayaz, M. J. Khan, N. Naseer, R. D. C. Amadeu, H. Sadia, and R. Nawaz, "An adaptive multi-robot therapy for improving joint attention and imitation of ASD children," *IEEE Access*, vol. 7, pp. 81808–81825, 2019.
- [36] A. Papadimitriou and K. N. Priftis, "Regulation of the hypothalamic-pituitary-adrenal axis," *Neuroimmunomodulation*, vol. 16, no. 5, pp. 265–271, 2009.
- [37] S. M. Smith and W. W. Vale, "The role of the hypothalamic-pituitary-adrenal axis in neuroendocrine responses to stress," *Dialogues Clin. Neurosci.*, vol. 8, no. 4, pp. 383–395, 2006.
- [38] T.-K. Lin, L. Zhong, and J. Santiago, "Association between stress and the HPA axis in the atopic dermatitis," *Int. J. Mol. Sci.*, vol. 18, no. 10, p. 2131, Oct. 2017.
- [39] A. T. Słominski, M. A. Żmijewski, C. Skobowiat, B. Zbytek, R. M. Słomiński, and J. D. Stekete, "Sensing the environment: Regulation of local and global homeostasis by the skin's neuroendocrine system," *Adv. Anatomy Embryol. Cell Biol.*, vol. 212, pp. XV, 115, and 1–98, 2012.
- [40] M. Wójcikowski and B. Pankiewicz, "Photoplethysmographic time-domain heart rate measurement algorithm for resource-constrained wearable devices and its implementation," *Sensors*, vol. 20, no. 6, p. 1783, Mar. 2020.
- [41] S. Ali, F. Mehmood, Y. Ayaz, M. J. Khan, H. Sadia, and R. Nawaz, "Comparing the effectiveness of different reinforcement stimuli in a robotic therapy for children with ASD," *IEEE Access*, vol. 8, pp. 13128–13137, 2020.
- [42] R. A. J. de Belen, T. Bednarz, A. Sowmya, and D. Del Favero, "Computer vision in autism spectrum disorder research: A systematic review of published studies from 2009 to 2019," *Transl. Psychiatry*, vol. 10, no. 1, pp. 1–20, Dec. 2020.
- [43] A. Kołakowska, A. Landowska, A. Anzulewicz, and K. Sobota, "Automatic recognition of therapy progress among children with autism," *Sci. Rep.*, vol. 7, no. 1, pp. 1–14, Dec. 2017.



MAREK WÓJCIKOWSKI received the M.Sc. degree in electrical engineering from the Gdańsk University of Technology, Poland, in 1993, and the Ph.D. degree in electrical engineering from the Gdańsk University of Technology, in 2002. Since 1994, he has been with the Department of Microelectronic Systems, Gdańsk University of Technology. His research interests include wireless sensor networks, programmable embedded systems, and low-power image processing.



BOGDAN PANKIEWICZ received the degree from the Department of Electronics, Gdańsk University of Technology, Poland, in 1993, and the Ph.D. degree in electronics from the Faculty of Electronics, Telecommunications and Informatics, Gdańsk University of Technology, in 2002. From the beginning of his career, he is associated with the Gdańsk University of Technology: first as an assistant from 1994 to 2002, has been an Assistant Professor since 2002, and has also been a Professor since 2017 with the Faculty of Electronics, Telecommunications and Informatics. He specializes in designing of analogue and digital integrated circuits, digital programmable circuits, and programmable system on chip. He is a co-designer of approximately ten application-specific integrated circuits (ASIC) in CMOS technologies from 2 μ m to 90nm and several systems made in FPGA technology. He has coauthored of the QoS coprocessor implemented at Intel Technology, Poland.



JACEK ŁUBIŃSKI received the M.Sc., Ph.D., and D.Sc. degrees from the Mechanical Engineering Faculty, Gdańsk University of Technology, Poland, in 1994, 2002, and 2018, respectively. He was a Mechanical Engineer and an Academic Teacher with the Mechanical Engineering Faculty, Gdańsk University of Technology. His current research interests include machine design, mechanical design, tribology and tribometry, tribometer development, mechanical engineering experiment design, forensic engineering, mechanical failure analysis, 3D printing, polymer technology, CAD, FEM, electronics in mechanical applications, and vice versa.



JAKUB MAJCHROWICZ received the M.Sc. degree from the Faculty of Electronics, Telecommunications and Informatics, Gdańsk University of Technology, Poland. His experience is about six years of Software Engineering mostly with Java Technology. During studies, he was an Intern with Intel Technology, Poland, and also a Software Developer with VoiceLab. Then, he was with Epam Systems.

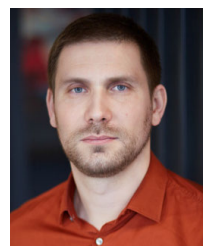

MICHAŁ T. TOMCZAK received the M.A. degree in sociology and the Ph.D. degree in social sciences from the University of Gdańsk, Poland, in 2004 and 2012, respectively. Since 2007, he has been with the Faculty of Management and Economics, Gdańsk University of Technology, Poland, where he is currently an Assistant Professor with the Department of Entrepreneurship. His research interests include assistive technology supporting individuals with autism spectrum disorders (ASD) and the improvement of human resources management processes for the needs of neurodiverse employees within a digital work environment.



DARIA MAJCHROWICZ received the B.Sc. degree in biomedical engineering and the M.Sc. degree in electronics from the Faculty of Electronics, Telecommunications and Informatics, Gdańsk University of Technology, Poland, and the Ph.D. degree (Hons.) in electronics from the Gdańsk University of Technology, in 2019. She worked in research projects financed by national Polish funds with the Department of Metrology and Optoelectronics, Gdańsk University of Technology. She

became the Head of the Preludium Project financed by the Polish National Science Centre. Her current research interest includes biophotonics. She focuses on low-coherence optical fiber sensors with nanodiamond structures and applications of optical measurements for measuring physical quantities.



ANNA WALASIEWICZ received the B.Ed. degree from the State University of Applied Sciences in Plock, Poland, in 2006, and the M.Ed. degree in early school education from the University of Warmia and Mazury in Olsztyn, Poland, in 2008. She is currently a Special Education Needs Teacher with the Jan Twardowski School Complex No. 5, Rypin, Poland, and deals with education and therapy of individuals with ASD.



TOMASZ KILIŃSKI received the M.D. degree from the Medical University of Gdańsk, Poland, in 1995, and the degree from in occupational medicine specialization from the Voivodeship Center Occupational Medicine, Gdańsk, in 2007. Since 2001, he has been with a District Sanitary and an Epidemiological Station in Gdynia. In 2007, he became a District Sanitary Inspector in Gdynia, Poland.



MAŁGORZATA SZCZERSKA received the Ph.D. and D.Sc. degrees in technical science, electronic engineering from the Gdańsk University of Technology, Gdańsk, Poland, in 2008 and 2016, respectively. She has supervised seven Ph.D. theses. She has published more than 60 research articles and review articles. She has authored or coauthored five patents. Her current research interests include the application of optical and electronic measurements in biomedicine.

...