

## STRUCTURE AND ALGORITHMS OF A DIAGNOSTIC DEVICE IN A WHEELED TRACTOR

Ryszard ARENDT, Ryszard MICHALSKI

Gdańsk University of Technology, University of Warmia and Mazury in Olsztyn  
ul. G. Narutowicza 11/12, 80-233 Gdańsk, fax: (+48) 58 347 24 87, email: [r.arendt@elvy.pg.gda.pl](mailto:r.arendt@elvy.pg.gda.pl)

### Summary

Diagnostic device monitors the tractor's technical condition and identifies the location of damaged components during operation. The diagnostic device detects and identifies the following types of defects: functional defects ( $u_f$ ) which affect performance, exhaust defects ( $u_e$ ) which increase toxic emissions and fuel consumption, defects that jeopardize driving safety ( $u_s$ ), defects that affect engine performance ( $u_d$ ). The key component of diagnostic device is on-board computer with touch screen, connected by USB/DeviceNet converter (master module) via the USB port. The CAN bus connects the interface module with three slave modules collecting data from sensors installed in various locations of wheeled tractor. Slave devices acted as data concentrator units. In the paper structure and basic algorithms are presented.

Keywords: wheeled tractor, algorithm, diagnostics device

### STRUKTURA I ALGORYTMY URZĄDZENIA DIAGNOSTYCZNEGO CIĄGNIKÓW KOŁOWYCH

#### Streszczenie

Urządzenie diagnostyczne jest ukierunkowane na monitorowanie i diagnozowanie, sprowadzone do kontroli stanu technicznego i lokalizacji elementów uszkodzonych ciągnika w trakcie eksploatacji. Założono możliwość wykrywania i lokalizowania uszkodzeń podzielonych na klasy związane z następującymi skutkami: funkcjonalnymi ( $u_f$ ) powodującymi ograniczenia efektywności pracy, emisyjnymi ( $u_e$ ) wywołującymi wzrost emisji związków toksycznych i zużycia paliwa, zagrażającymi bezpieczeństwu ruchu ( $u_s$ ) ciągnika, pogarszającymi dynamikę ( $u_d$ ). Podstawowym elementem diagnostycznym jest komputer pokładowy z ekranem dotykowym, połączony łączem USB z konwerterem protokołu USB na DeviceNet, pracującym jako „master”. Sieć CAN łączy konwerter z trzema urządzeniami akwizycji danych czujników zainstalowanych w wybranych punktach ciągnika kołowego. Artykuł prezentuje podstawowe algorytmy urządzenia.

Słowa kluczowe: ciągnik kołowy, algorytm, urządzenie diagnostyczne

## 1. INTRODUCTION

The proposed mechatronic system monitors and diagnoses the technical condition of a wheeled tractor and identifies damaged elements during the tractor's operation. The system detects and identifies defects that are classified into the following groups in view of the resulting consequences [1, 2, 7]:

- functional defects ( $u_f$ ) which inhibit performance (power, torque, towing force, working speed, fuel consumption),
- exhaust defects ( $u_e$ ) which increase toxic emissions and fuel consumption due to a malfunction of the fuel supply system, layout of the diesel engine and the power transmission system,
- defects that jeopardize driving safety ( $u_s$ ) affecting the following tractor systems: brake, suspension, steering and lights,
- defects that affect engine performance ( $u_d$ ) and driving parameters in a tractor, including

decreased acceleration, delayed response to changes in movement parameters, unequal power levels, significant loss of power and moment of force, etc.

A diagnostic device necessitates the development a system for the acquisition and processing of performance data in a wheeled tractor. Such a system consists of a large number of cable connections and an on-board computer.

The Controller Area Network is a vehicle bus standard [5, 9] which contains a detailed communication protocol and has the following features:

- it supports the development of dispersed systems operating in real time – power supply and communication subsystems are connected by network nodes;
- it is highly resistant to transmission errors;
- data transmission speed reaches 1Mb/s (CANopen) and 0.5Mb/s (DeviceNet);

- it has an open structure which supports the incorporation of new nodes;
- collective communication is based on master-slave tasking.

CANopen and DeviceNet are the most popular specialized networks based on the CAN protocol. CANopen is available as European standard EN50325-4. CANopen networks support the operation of machines and devices which are embedded systems. They are used in vehicles, in particular passenger cars, the railway industry, ships, aircraft, control systems for small objects, and they are increasingly often deployed in complex production lines. DeviceNet was developed by Honeywell in 1989 based on the CAN technology as a Smart Distributed System (SDS) standard. The DeviceNet protocol was engineered in 1994 by Allen-Bradley as a combination of the CAN protocol and the Common Industrial Protocol (CIP). SDS gained widespread popularity in the US, and it is used to automate production lines and control vehicle subassemblies.

A dispersed tractor diagnostic system was proposed due to the simplicity of cable connections and the ease of communication with the existing OBD systems. Up to 64 data acquisition nodes or two-state and analog control nodes can be used in the system. Dedicated slave nodes such as thermocouple modules and acceleration sensors can be additionally incorporated.

In networks with a DeviceNet protocol, data acquisition procedures involve two types of messages: information about input/output status (I/O messages) and general configuration data (explicit messages). There are three data exchange methods: Change of State (COS), Bit Strobe (BS) and Polling (PO). The COS mechanism uses the connection only when the status of the device has changed. A typical

COS transmission is a one-way and one-to-many transmission. Cyclic data exchange with a defined cycle repeat time is a variant of the COS mechanism. The BS master mechanism sends a strobe signal to the network. Transmitted data can be received by all network devices. Devices configured for processing BS messages send a data frame to the master device in a given sequence (based on the address). In the PO mechanism, the master device communicates cyclically with slave devices based on the indicated addresses. A slave device sends a data frame upon request from the master device.

In the CAN standard data frame with the DeviceNet protocol, 8 bytes of data are transmitted. Typical nodes support 4 sensors which process analog data into 2 bytes of data per sensor. Nodes are identified based on their Media Access Control (MAC) address. Larger data transmissions require messages from many frames or the use of other mechanisms.

This paper discusses the hardware structure, components, object data and software for the proposed diagnostic system of a wheeled tractor.

## 2. HARDWARE STRUCTURE OF A DIAGNOSTIC SYSTEM

The key component of the proposed diagnostic system (Fig. 1) is the Fujitsu FUTRO S100 on-board computer in shock and vibration-proof housing, with passive cooling and a 16 GB Compact Flash memory card. The computer was provided with a NVOX LCD 10" VGA/FVAT touch screen. The following software was used: Windows XP-2000, USB/DeviceNet interface module and a diagnostic program. The installed memory card supports the operation of the diagnostic device.

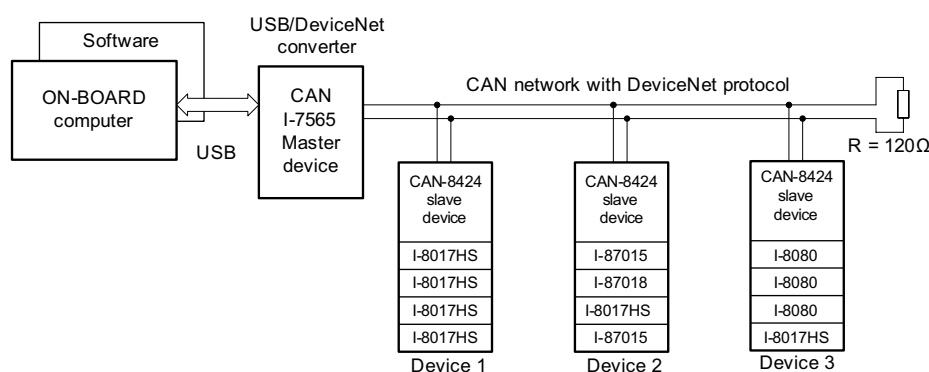

Fig. 1. Structure of a diagnostic device in a wheeled tractor

The computer was connected to the I-7565 USB/DeviceNet master device via the USB port. The CAN bus connects the interface module with three slave devices collecting data from sensors installed in various locations of a wheeled tractor. Slave devices act as data concentrator units. Every device has a unique ID and is equipped with 4 input

(output) cards which correspond to the range and type of the measured signals.

ICP DAS network devices and data acquisition modules with high resistance to shock and temperature change ( $-25^{\circ} \div +75^{\circ}\text{C}$ ) were used. The diagnostic device was designed for use with 4 types of data acquisition modules:

- I-8017HS – analog input module which supports the acquisition of data from 8 analog signals ( $\pm 10V$ ,  $\pm 5V$ ,  $\pm 2.5V$  and  $\pm 20mA$ ) or 16 analog signals excluding negative values;
- I-87015 – analog input module of RTD sensors which supports the acquisition of data from 7 analog signals in resistance sensors of various type and temperature range; Pt100 sensors with  $0^\circ \div +200^\circ C$  temperature range were used;
- I-87018 – analog input module which supports the acquisition of data from 8 analog signals with varied range, including the output voltage range of thermocouples; type K thermocouples with  $-270^\circ \div +1372^\circ C$  temperature range were used;
- I-8080 – pulse input module which supports the acquisition of data from 4 (8) two-state signals, up/down pulse counting and frequency measurement. The module was used to measure the rotational speed of shafts with the involvement of pick-up sensors.

The proposed diagnostic device is a research model whose data acquisition capability exceeds the needs of a standard diagnostic device in a wheeled tractor. The maximum quantity of available analog is limited to 144 sensors. Data transmission speed in the CAN network with the DeviceNet protocol reaches 500kb/s.

Many of the interesting features of the DeviceNet protocol described in the introduction have been lost due to high data concentration in three data acquisition devices. COS, BS and PO communication mechanisms for three devices are capable of sending 3 frames of 8 bytes each, i.e. data from only 12 sensors. For this reason, communication mechanisms based on explicit messages had to be used in the proposed diagnostic program.

### 3. STRUCTURE OF THE DIAGNOSTIC INTERFACE TOOL IN A WHEELED TRACTOR

The following diagnostic procedures were deployed at the current phase of development:

- on-line diagnostics – cyclic operation of the data acquisition program with data readout from sensors at intervals of  $T = 1s$  (default value), diagnosis, error code generation;
- vibration tests – acquisition of data files from acceleration sensors, the use of fast Fourier transform and dedicated diagnostic procedures;
- engine performance tests – acquisition of data files from shaft speed sensors, determination of speed and acceleration characteristics under given operating conditions based on the knowledge of engine performance diagnostics;

- steering system tests – controlling steering clearance.

The main window of the diagnostic program is presented in Fig. 2.

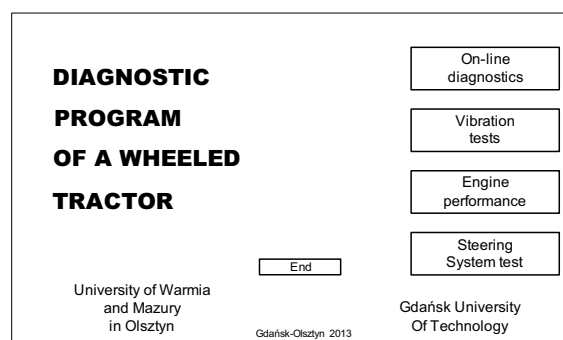

Fig. 2. Main window of the diagnostic program

The data acquisition system can be configured and diagnostic and testing procedures can be initiated in the respective diagnostic or test window.

#### 3.1. Configuration subprogram

In the first stage of configuring the data acquisition system based on CAN-8424 network devices, hardware parameters are defined and the transmitted measurement data is organized with the use of the SlaveUtility (ICP DAS) application. The user defines the types of modules installed in successive punch-down blocks of the CAN device, the functions of each input and, optionally, the sensitivity ranges of module inputs. Data inputs (connected sensors) and the readout sequence are defined in the Assembly Object layer of the CAN network. One data frame can contain up to 8 bytes, and up to 16 frames can be described. Data selected by the user is saved in an Electronic Data Sheet (EDS) file which is used to configure the CAN-8424 module. A text file is additionally generated for the user.

Read data contains measured parameters – 2 bytes per measurement. The configuration subprogram assigns the name of the measuring element to the measurement, it converts bytes to numeric values in MKS units and assigns the name of the measuring element to the calculated variable. An unnamed field implies that a given measurement was omitted.

The user enters the following data in the configuration subprogram (Fig. 3):

- MAC address of a data acquisition device,
- number of lines of transmitted measurement data,
- names of measuring devices.

The designed subsystem also features a data configuration option based on connected data frames of different device modules for 16 to 48 byte transmissions. The above option relies on the Application Object layer of the CAN network.



Subject to module type, successive inputs and the assigned bytes are displayed on the screen. When a name is assigned to an input, a given measurement is taken into account, and its physical value is computed. The above option was used to configure testing subprograms.

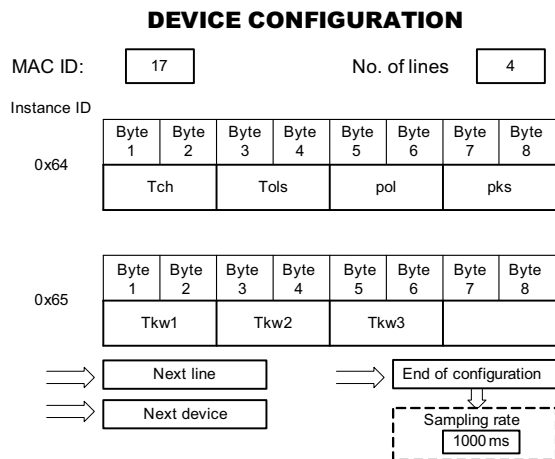

Fig. 3. Screenshot of the subprogram for configuring measuring data

### 3.2. Conversion of measurement data

Measurement modules have different data representations in bytes. The following information should be taken into account during conversion:

- number of data bytes – 2, 4 and 6 bytes are used,
- number of bits in two bytes of data – 14 and 16 bits are used,
- maximum range of data in 2 bytes, e.g. 7FFFh, 1FFFh,
- minimum range of data, e.g. 0000h, for a negative range – 2000h,
- maximum and minimum physical ranges of a sensor which correspond to data ranges in bytes,
- effective measuring range of  $4 \div 20\text{mA}$ , for the applied range of  $\pm 20\text{mA}$ ,
- conversion of physical units.

Eleven computing procedures have been developed for the conversion of measurement data. The procedure is selected based on the name of the measuring device.

The measured parameters of a wheeled tractor can be viewed during the online diagnostic process (Fig. 4).

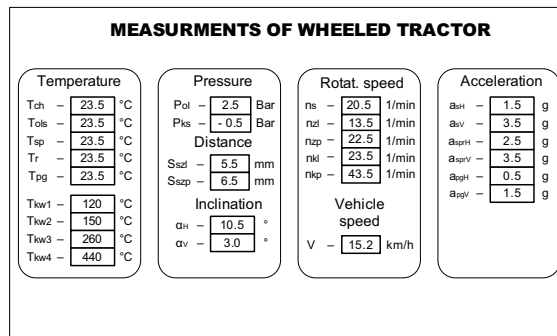

Fig. 4. Window displaying the measured parameters of a wheeled tractor

Computed parameter values which are not available during direct measurement (another window) can also be previewed.

## 4. SELECTED PROGRAM ALGORITHMS

A real-time clock controls data readout in the online diagnostic process. The data readout procedure is called at time intervals  $T$ . Bytes written in a table are converted into physical values that are assigned to variables named after the measuring sensor. Physical values of performance variables which are not available during direct measurements are computed based on registered data and the parameters stored in memory. Registered and computed values are used in the diagnostic process, and they may be displayed on the screen. Cause-and-effect relationships between a fault and its symptoms are identified as defects and are communicated by the respective error codes.

### 4.1. Real-time control

In the Windows environment, real-time control is problematic due to difficulties with stability and sampling frequency. The available tools in popular programming languages do not support stable and precise time control. The *WinApi* library offers the only solution to the problem.

A separate time control option with the highest priority (*tpHighest*) has been introduced to guarantee the accuracy of time intervals between successive measurements. The accuracy of intervals between measurement samples was maximized with the use of the *timeBeginPeriod* function which increases the precision and resolution of the Windows timer (this function is used in real-time applications and multimedia systems). The value of the expected stable timer resolution in milliseconds is the function parameter. The function is called directly before the use of other counting functions and measurements that require a stable real-time clock.

Accurate time measurements are performed with the involvement of the *QueryPerformanceCounter* function which returns the number of the clock cycle performed by the processor as a parameter and the



*QueryPerformanceFrequency* which indicates the frequency of clock cycles.

A waitable timer object for synchronizing timing tasks has been used to control the passage of time and the arrival of a specified due time. When the "time synchronization object" has been created, the user can control the expiry of successive time intervals. Time intervals can be set in accordance with Windows instructions with a minimum step of 100 ns.

#### 4.2. Data readout procedure

The MAC address of the device and the number of lines (successive Instance ID numbers, beginning from 0x64) are specified in the Assembly Object layer of the configuration subprogram in the data acquisition system. Data can be cyclically read from the loop with the use of explicit messages.

The data readout procedure is called cyclically at intervals  $T$  which are specified in the configuration subprogram. Two bytes of data are combined to form words, and they are entered into the table. Identical indicators are found in the table specifying the names of measurement sensors in the configuration subprogram.

#### 4.3. Data conversion procedure

The table specifying the names of measurement sensors is reviewed. Elements without names are omitted. The procedure assigned to a named element is called. The table index also indicates the source of measurement data which is sent to the procedure. The computed physical value of a parameter is assigned to the variable named after the sensor.

#### 4.4. Procedure of computing physical values which are not available during direct measurements

Not all physical parameters are measured directly, and they may have to be computed independently. The most important values are:  $N_e$  – effective engine power and  $M_e$  – effective torque. Parameters were computed mechanically based on formulas (1) ÷ (5):

$$V = \frac{\Pi n_k r_d}{30} \text{ [m/s]}, \quad (1)$$

$$a = \frac{\Delta V}{\Delta t} \text{ [m/s}^2\text{]}, \quad (2)$$

$$F = ma \text{ [N]}, \quad (3)$$

$$N_e = FV \text{ [kW]}, \quad (4)$$

$$M_e = \frac{F r_d}{i \eta_c} \text{ [Nm]}, \quad (5)$$

where:  $V$  – velocity read from a GPS receiver,  $n_k$  – average velocity of drive wheels,  $a$  – acceleration,  $F$  – inertial force,  $\eta_c$  – total efficiency of the power

transmission system,  $i = \frac{\Pi r_d n_s}{30V}$ ,  $m$  – tractor mass,

$r_d$  – rolling radius,  $n_s$  – rotational speed of engine shaft,  $i$  – overall gear ratio.

The percentage relative slip ratio of rear axis wheels  $S_{ot}$  is determined based on the following formula:

$$S_{ot} = \left( \frac{n_{kl} + n_{kp}}{n_{zl} + n_{zp}} - 1 \right) 100\% . \quad (6)$$

The below equation is used to calculate slip based on GPS data:

$$s = \frac{V - \omega R}{V} , \quad (7)$$

where:  $\omega = 2\Pi n_k / 60$  – angular velocity of drive wheels,  $\omega R$  – circumferential speed of the drive wheel tire.

#### 4.5. Diagnostic procedure

Parameter values are analyzed at various engine states. During effective tractor operation, the measured values should fall within the given intervals. A defect changes the value of measured parameters and produces a "diagnostic symptom" [3, 4].

In the proposed diagnostic system, a defect is defined as a destructive event which deteriorates tractor performance and effectiveness [6, 7]. A diagnostic system should effectively identify all defects. A tractor's fault  $S_N$  is caused by one of the four categories of defects  $\{u_f, u_e, u_s, u_d\}$ , and the above is expressed by formula (8):

$$S_N \Rightarrow \{u_f \cup u_e \cup u_s \cup u_d\} \neq 0 . \quad (8)$$

The diagnostic process verifies the relationship  $R$  between a defect (fault) and a diagnostic symptom. Specific defects (9) or a possible set of defects (10) (one-to-many relationship) can be identified for cause-and-effect relationships between a fault  $f_i \subset F$  and symptoms  $s_j$  which are represented by set  $S$  based on formula (9) or (10):

$$R : \{s_j\} \Rightarrow f_i , \quad (9)$$

$$R : \{s_j\} \Rightarrow \{f_i\}_{kj} , \quad (10)$$

Defect sets are represented by error codes displayed on the screen of a tractor's diagnostic device.

Diagnostic tests are presently being carried out, and cause-and-effect relationships between a defect (fault) and a symptom (values of a selected set of physical parameters) are identified in a wheeled tractor.

#### 5. CONCLUSIONS

The proposed diagnostic system for a wheeled tractor was developed with the involvement of the CAN system and the DeviceNet protocol engineered in 2008-2010. The construction of a diagnostic

device was fraught with problems due to incomplete ICP DAS documentation.

The developed device is currently being tested in a wheeled tractor to identify cause-and-effect relationships between damage symptoms and four groups of defects. Vibration tests will support the determination of the effective band of registered frequencies – testing time influences the evaluation of the lowest frequencies, whereas sampling rate affects the highest analyzed vibration frequencies.

**Acknowledgments:** This study was supported by research grant No. N N504 513740 from the Ministry of Science and Higher Education.

## REFERENCES

- [1] Arendt R., Michalski R.: *Struktura systemu diagnostycznego ciągnika kołowego*. Zeszyty Naukowe Instytutu Pojazdów, 2012, nr 3 (89).s.5-12,
- [2] Arendt R., Michalski R.: *Functional structure of diagnostics system for wheeled tractors*. *Pomiary Automatyka Robotyka*, 2012, nr 12, s. 117-120.
- [3] Kościelny J. M.: *Diagnostyka zautomatyzowanych procesów przemysłowych*. Wyd. Akademicka Oficyna Wydawnicza EXIT; Warszawa 2000.
- [4] Korbicz J., Kościelny J. M., Kowalczyk Z., Cholewa W.: *Diagnostyka procesów, modele, metody sztucznej inteligencji, zastosowania*. WNT, Warszawa 2002.
- [5] Merkiś J., Mazurek S.: *Pokładowe systemy diagnostyczne pojazdów samochodowych*. WKŁ, Warszawa 2000.
- [6] Michalski R.: *Diagnostyka maszyn roboczych*. Wyd. ITE Radom – Olsztyn, 2004.
- [7] Michalski R., Gonera J., Janulin M., Arendt R.: *Structural analysis of wheeled tractor oriented towards damage diagnostics*. Monografie, studia, rozprawy “Selected problems of mechanical engineering and maintenance” M29, Politechnika Świętokrzyska, Kielce 2012 s. 16-30.
- [8] Natke H. G., Cempel C. *Model-Aided Diagnosis of Mechanical Systems: Fundamentals, Detection, Localization, Assessment*. Berlin. Springer-Verlag 1997.
- [9] Niziński S., Wierzbicki S.: *Zintegrowany system informatyczny sterowania pojazdów*. *Diagnostyka*, nr 30 t.2/2004. s. 47-52.
- [10] Zimmermann W., Schmidgall R.: *Magistrala danych w pojazdach. Protokoły i standardy*, WKiŁ 2008.



**dr hab. inż. Ryszard Arendt** is a professor of the Faculty of Electrical and Control Engineering in Gdansk University of Technology, G. Narutowicza 11/12, 80-233 Gdansk, Poland. E-mail: r.arendt@ely.pg.gda.pl. His

current research interests are: an application of artificial intelligence in automation of ship systems design, mechatronic systems and diagnostic of control elements and systems.



**prof. dr hab. inż. Ryszard Michalski** is a professor of the Faculty of Technical Sciences in University of Warmia and Mazury in Olsztyn, Oczapowskiego 11, 10-736 Olsztyn, Poland. E-mail: ryszard.michalski@uwm.edu.pl. His current research interests are: technical diagnostic,

reliability, repair engineering and system analysis of vehicle and working machines exploitation.