

Post-print of: WILK, Barbara K.; URBAŃSKI, Aleksander. The impact of the shape of screen openings on groundwater flow to a deep drilled well. *Czasopismo Techniczne*, 2018, Volume 11, p. 149-162, lis. 2018. ISSN 2353-737X. Available at: <<http://www.ejournals.eu/Czasopismo-Techniczne/2018/Volume-11/art/12807/>>. Date accessed: 23 lis. 2018 doi:<http://dx.doi.org/10.4467/2353737XCT.18.169.9425>.

BARBARA K. WILK*, A. URBAŃSKI**

THE IMPACT OF THE SHAPE OF DEEP DRILLED WELL SCREEN OPENINGS ON THE FILTRATION PROCESS IN FULL SATURATION CONDITIONS

WPLYW KSZTAŁTU OTWORÓW FILTRU STUDNI GŁĘBINOWEJ NA PROCES FILTRACJI W WARUNKACH PEŁNEGO NASYCENIA

Abstract

The authors propose a supplementary method of modelling seepage flow around the deep drilled well screen. The study applies 3D numerical modelling (FEM) in order to provide an in-depth analysis of the seepage process. The analysis of filtration parameters (flow distribution $\mathbf{q}(\mathbf{x},t)$ and pressure distribution p) was conducted using the ZSoil.PC software system. The analysis indicates that the shape of perforation is of secondary importance during the deep bore well screen selection.

Keywords: deep drilled well screen, FEM, ZSoil, filtration.

Streszczenie

Autorzy proponują uzupełniającą metodę modelowania filtracji wokół filtru studni głębinowej. W pracy zastosowano modelowanie numeryczne 3D (MES) w celu dogłębnej analizy parametrów procesu filtracji. Analizę parametrów filtracji (rozkład prędkości filtracji $\mathbf{q}(\mathbf{x},t)$ oraz rozkład ciśnienia p) przeprowadzono za pomocą systemu MES ZSoil.PC. Analiza wykazała, że kształt perforacji ma drugorzędne znaczenie podczas selekcji filtru studni głębinowej.

Słowa kluczowe: filtr studni wierconej; MES; Zsoil; filtracja

* M. Sc. Eng. Barbara Krystyna Wilk, Department of Water and Wastewater Technology, Gdansk University of Technology, 11/12 Gabriela Narutowicza Street, 80-233 Gdansk, Poland, e-mail: Barbara.K.Wilk@gmail.com

** Associate Professor, D. Sc. Eng. Aleksander Urbański Institute of Geotechnics, Cracow University of Technology, 24 Warszawska Street, 31-155 Cracow, Poland.

1. Introduction

Groundwater, accessed through deep drilled wells, usually supplies water of a quality superior to surface waters [8]. The groundwater is a valuable natural resource, readily used in e.g. industrial, medical or municipal applications [2,27]. However, the groundwater resources are much more scarce than surface waters. Therefore, it is crucial to develop and broaden the knowledge on the quantity and quality of groundwater, and on the appropriate methods of its withdrawal [15].

The correct usage of groundwater resources requires an in-depth knowledge on construction and operation of deep drilled wells [1]. It should be pointed out that a screen is one of the key elements of the drilled well, as it helps to maintain the required well performance and deliver water free of a fine soil fraction [7]. Therefore, when designing a deep drilled well, its technical parameters must be carefully considered [21].

A thorough literature review on the design of deep drilled well screens failed to answer the question: Does the shape of a screen perforation have a significant impact on a screen performance? The review of the available literature has only managed to produce the conclusion that the key technical parameters of a deep drilled well screen include: the total area of screen openings, the size of an opening (depending on a size of the aquifer grain or a side fill adhering to the screen) and a surface area of a screen perforation. It should also be pointed out that thus far, the analysis of a seepage flow in the vicinity of a deep drilled well screen has been based mainly on empirical formulas. The design groundwater inflow rates, determined by individually laboratories, differed significantly from each other. Therefore, a detailed analysis of seepage related fields (flow distribution $\mathbf{q}(\mathbf{x},t)$, pressure distribution $p(\mathbf{x},t)$) was conducted using the ZSoil PC software, which employs the 3D numerical modelling methodology (FEM) and a homogenisation technique.

Groundwater filtration in full saturation conditions

Seepage, as the movement of groundwater, is influenced by a variety of factors, i.e. grading of soil, its structure, porosity and cracking [2]. The filtering properties are determined with the filtration coefficient k . Assuming a full saturation of the porous medium, the average flow q in an one dimensional situation, can be determined from the following formula, [8], commonly known as Darcy's law. These, assuming that the fluid's viscosity, temperature and density as constant [8], takes form:

$$q = -k \cdot J \quad (1)$$

In that model, the seepage flow (Darcy velocity) is directly proportional to the hydraulic gradient J , and k is the proportionality coefficient. The Darcy's law is applicable only to laminar flows and is invalid for rocks or soils with a very high permeability [8,25, 16, 15]. This limitations of the validity of Darcy law can be expressed by the notion of dimensionless Reynolds number Re :

$$Re = \frac{\rho \cdot q \cdot d}{\eta} \quad (2)$$

where: ρ -water density, η -dynamic viscosity of ground water ($=0.0013$ kg/m/s), d -diameter of flow channel. In ground water seepage problems, parameter d corresponds to an average diameter of a "channel" between solid soil particles. This characteristic dimension of a ground microstructure is related to soil porosity, grain sizes and its distribution curve. Different sources gives different limiting values of Re preserving laminar flow regime, ranging from $Re=1\div 10$ in Bear [3], to $Re=30$ in Houben [10].

Considering a general, three-dimensional case, with a constant filtration coefficient and an isotropic medium, the flow components can be calculated from the following formulas [14, 16]:

$$\mathbf{q} = -k \cdot \mathbf{grad}(p / \gamma_w + Y) \equiv q_i = -k(H + Y)_{,i} , \quad (3)$$

Where: γ_w - volumetric weight of the fluid, Y - the potential of the gravity field, which in the analysed flow homogenisation case (close to the screen) is negligible. However, it is important while analysing filtration in macroscopic systems (e.g. while looking at a free surface close to the screen or at a flow distribution along the screen height). The Darcy's law, as a constitutive equation for the seepage in a porous medium, must be supplemented by a balance equation, which in a full saturation conditions, takes the following form:

$$\mathit{div} \mathbf{q} = \frac{\partial q_x}{\partial x} + \frac{\partial q_y}{\partial y} + \frac{\partial q_z}{\partial z} = 0 \equiv q_{i,i} = 0 . \quad (4)$$

Expressing equation (4) through pressure p or hydraulic head H , the Laplace's equation is obtained:

$$\nabla^2 p = \frac{\partial^2 p}{\partial x^2} + \frac{\partial^2 p}{\partial y^2} + \frac{\partial^2 p}{\partial z^2} = 0 \equiv p_{,ii} = 0 \equiv H_{,ii} = 0 . \quad (5)$$

This equation serves as the basis for a numerical analysis conducted using the Finite Elements Method (FEM), which is discussed further in this paper. To solve the boundary problem the conditions applicable to each point of the boundary of the calculation domain has to be determined. Thus, for the problem presented in Fig. 2 the first-type (Dirichlet) boundary condition (equation 6) applies to pressure (where its value is known, i.e. within the opening $\bar{p} = 0$ and $\bar{p} = 1$ on the outer surface):

$$p = \bar{p} \quad (6)$$

The second-type (Neumann) boundary condition, for the flow perpendicular to the boundary (equation 7), applies to the remaining parts of the periodic cell boundary, where a lack of normal flow is caused by the presence of a filter pipe, or by a flow symmetry and periodicity.

$$\mathbf{n} \cdot \mathbf{q} \equiv n_i q_i = q_n = \bar{q}_n = 0 \quad (7)$$

Screen in a deep drilled well

The screen is an element of the filter column which also comprises: a subfilter pipe, which very often acts as a sedimentation basin and an upper pipe, which connects the screen with the ground surface [21,13]. Designing of deep drilled well screens focuses mainly on their following features: length, elevation, perforation, diameter and acceptable screen performance. The main objective of the screen is thus to let water pass from the aquifer into the well and prevent loose soil, sediment and rock from entering the well while minimizing hydraulic resistance. With regard to the above, in the past, well screens were selected with the largest possible opening area (lowest entrance velocity) [16]. Latest field experience and laboratory tests have shown that the average entrance velocity of water moving into the screen should not exceed 0.6-1.2 m/s (provided screens have open areas greater than 3 to 5%) [1,5,11-13]. On the other hand, Water Well Construction Standard ANSI/NGWA-01-14 does not specify maximum screen entrance velocity due to the fact that different variants of entrance velocity and screen open area can give similar values for the designed screen length [1,11-13]. The document indicates moreover that the perforation of well screen should be as large as possible, providing a laminar flow entrance velocity. The size of well screen perforation is also largely dependent on the type of aquifer and the use of a gravel pack [2]. Additionally, well screens should be characterised by correct slot design to minimize blockage, corrosion resistant material and a structure that hinders the formation of sediments of mechanical, chemical or biochemical origin [19, 20]. They should also be designed to prevent sanding the well during its normal operation. A proper screen ensures a long life and a trouble-free operation of the deep drilled well [15]. Hence, the following types of screens may be used: framed screens, mesh screens, gravel screens, and various types of special structures (e.g. made with porous concrete prefabricates). The framed screens with a proper perforation are the most frequently used type of screen [16, 22].

Framed screen perforation

Framed well screens are usually made as pipes with a series of openings (of a specific shape) to enable water to pass through. The openings can be round or rectangular (slots) [16]. The diameter or width of screen openings are selected according to the grain size of the aquifer. The Abramow's formulas can be applied to calculate the dimensions of the screen openings, based on the uniformity coefficient of grains of a filter layer, which is in a direct contact with the filter (η) [7,15,21]. It should be noted that the diameter of openings should not be smaller than 10 mm and not larger than 25 mm. The slot width should not exceed 10 mm. When designing a framed screen perforation, the screen flow rate coefficient must be calculated from the following formula [15]:

$$m_f = \frac{f}{F} \quad (8)$$

where f - total area of the openings (active surface); F - surface area with perforation, screen surface (working surface). For a round openings $m_f \leq 0.25$; for slots $m_f \leq 0.15$.



2. Materials & Methods

Modelling of a groundwater filtration with the ZSoil.PC FEM software was preceded by calculations of technical parameters of a deep drilled well. The calculations were carried out according to the groundwater intake design principles, formulated by Wiczysty and Gabryszewski for the given input data. This way a reliable and accurate data was obtained for further numerical calculations. Following the calculation of the screen length and diameter, the dimensions of three types of openings were determined. They were: round holes (chessboard) and slots (longitudinal and transversal). The openings were distributed on the screen surface and the total area of a screen perforation was maintained equal for each case. The appropriate side fill grain size was selected to ensure that the grains will not pass through the screen, i.e. to protect the well against sand accumulation. Table 1 presents the assumptions and results for further calculations in ZSoil. PC (FEM) (Table 1.).

Table 1. Input data and major results of deep drilled well screen calculations

Aquifer grain size	Screen openings	Water table	Calculated screen length, m	Calculated screen outer diameter, m	Calculated screen inner diameter, m	Calculated diameter of a side fill pipe ($d_{50} = 4.0$ mm), m
$d_{10} = 0.32$ mm $d_{50} = 0.35$ mm $d_{60} = 0.39$ mm	a) round hole perforation (chessboard) b) longitudinal slot perforation c) transversal slot perforation	Free water table 12 m BGL	2.80	0.195	0.175	0.395

Provided below are the dimensions of the deep drilled well screen, with the analysed options:

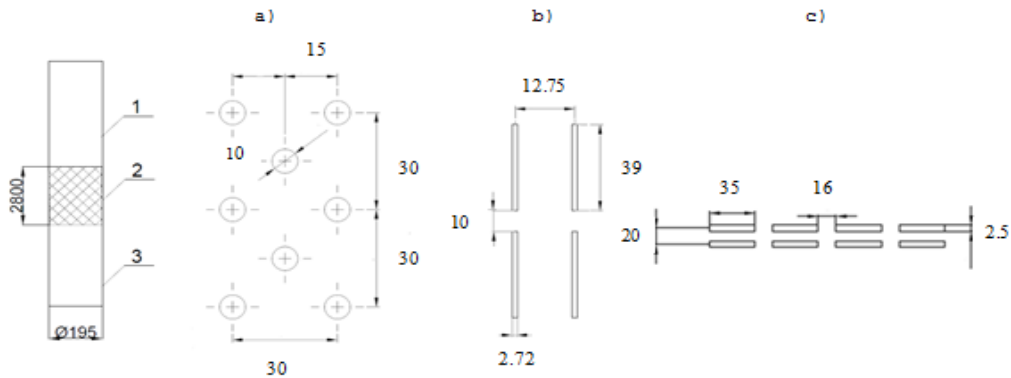

Figure 1. Deep drilled well screen (1 - upper pipe, 2 - filter, 3 - subfilter pipe) with $mf = 8.35\%$: a) round hole perforation (chessboard), b) longitudinal slot perforation, c) transversal slot perforation. All dimensions in [mm].

After determining the screen size for the given application, the groundwater filtration flow was determined for 3 deep drilled well screens, differing in screen opening shapes; flow rate coefficients for each option remained equal ($mf \approx 8.35\%$). The numerical analysis was based on a flow homogenisation, assuming its periodicity, both along and around the pipe. The periodic cell was created, defined as a section of a hollow cylinder with internal radius $R1=97.5$ mm and side fill dimensions $a = 100$ mm, identical for each type of perforation. The radius $R3 = 297.5$ mm, for the outer cell surface, was selected as those, where any visible fluctuations of the flow vector \mathbf{q} vanish.

Two filtration coefficients in a side fill and a surrounding aquifer zone have been considered:

- 1) with different values, i.e.: $k=1.0[\text{mm/s}] = 1.0e^{-3}[\text{m/s}]$ for a side fill, $k_1=0.01k=1.0e^{-5}[\text{m/s}]$ – for an aquifer strata; a medium sand was adopted in this study,
- 2) with a constant value of $k_1=k=1.0[\text{mm/s}] = 1.0e^{-3}[\text{m/s}]$, assumed in both zones.

It is worth to note, that these are just approximate, indicative values, roughly corresponding to the real numbers. Nevertheless, due to linearity of a boundary problem, the obtained results will illustrate correctly the nature of the phenomenon, and could be generalized to other data, of course only if conditions of Darcy law validity, described in p.1, holds.

The 3D FEM models of a periodic cell for 3 types of openings with the assumed boundary conditions (p – pressure [kN/m²], q_n –flow normal to the surface) are shown in Fig. 2.

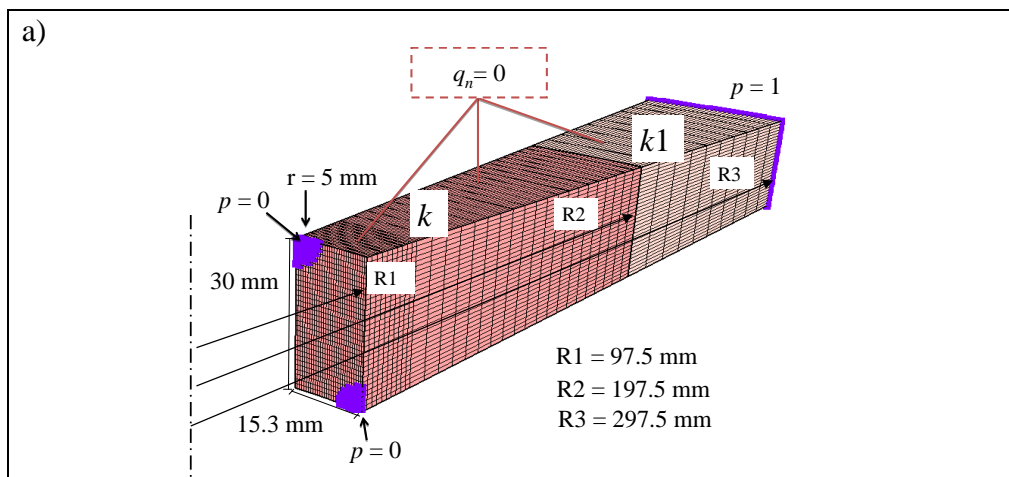

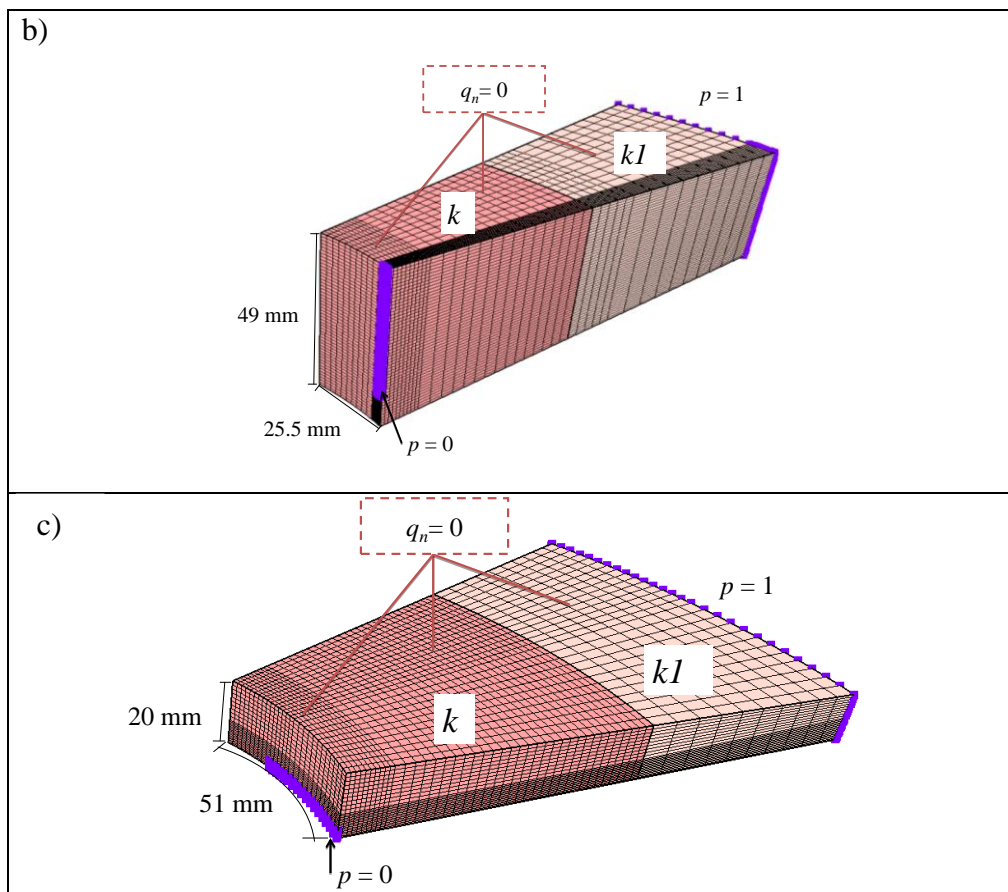

Figure 2. A periodic cell of a deep drilled well screen with perforation and a screen adjacent zone: a) circular hole perforation, b) longitudinal slot perforation, c) transversal slot perforation.

Moreover, it is assumed that the depth of screen tube wall is so small, that pressure distribution along a segment between outer and inner surface of a tube may be approximated by a sudden drop to $p=0$ value on the outer surface of a screen tube, being the inner surface of the periodic cell.

3. Results and discussion

The pressure field was determined for all $3 \times 2 = 6$ analysed cases. The pressure distribution for 3 perforation types is very similar, i.e. the closer to the centre of the opening, the lower the pressure; pressure increased with a distance from the perforation. In the case of filtration setups no.1a, 1b and 1c a significant disproportion (100 x) of a filtration coefficient between a highly permeable layer of a side fill and the aquifer close to

the pipe is observed. This disproportion causes a drop in the value of the pressure close to the pipe (Fig. 3.).

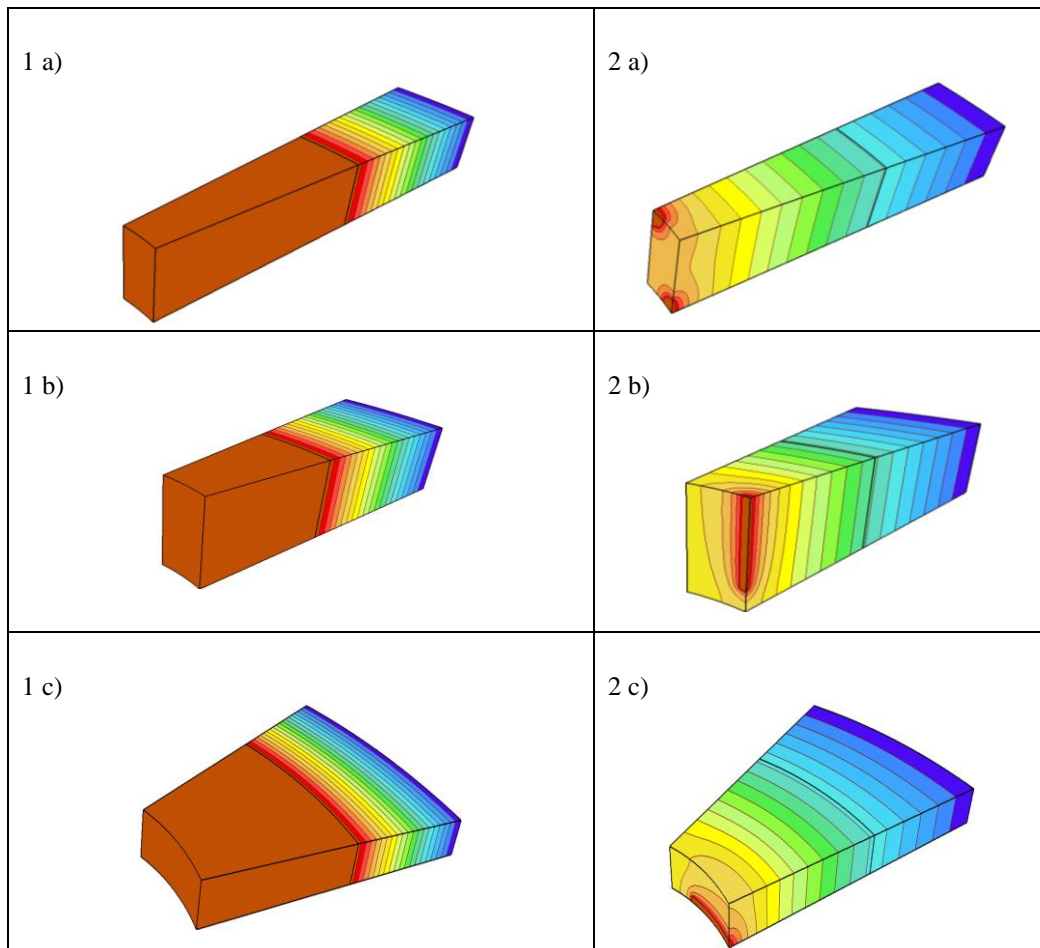

Figure 3. Pressure distribution in the periodic cell: a) round hole perforation, b) longitudinal slot perforation, c) transversal slot perforation for both filtration setups; the maximum pressure value $p=1$ kN/mm² (dark blue), the minimum pressure value $p=0$ kN/mm² (brown)

Numerical studies performed by a few authors [15, 22, 23, 25] describe drop of pressure in the near field of the well screen. Szanyia et al. (2018) describe i.a. pressure distribution near the well screen (crude oil inflow to a horizontal drilling well), whereas the exact pressure distribution for different screen perforation at micro-scale has not been calculated there, this is a novelty.

After specifying the boundary conditions, the results clearly indicated that the highest flow values were found at the well screen openings and in their immediate vicinity and they dropped with an increased distance from the screen openings. Also, the individual

flow vectors ($|\mathbf{q}|$) at the outer surface of the computational domain were read, for each case presented below.

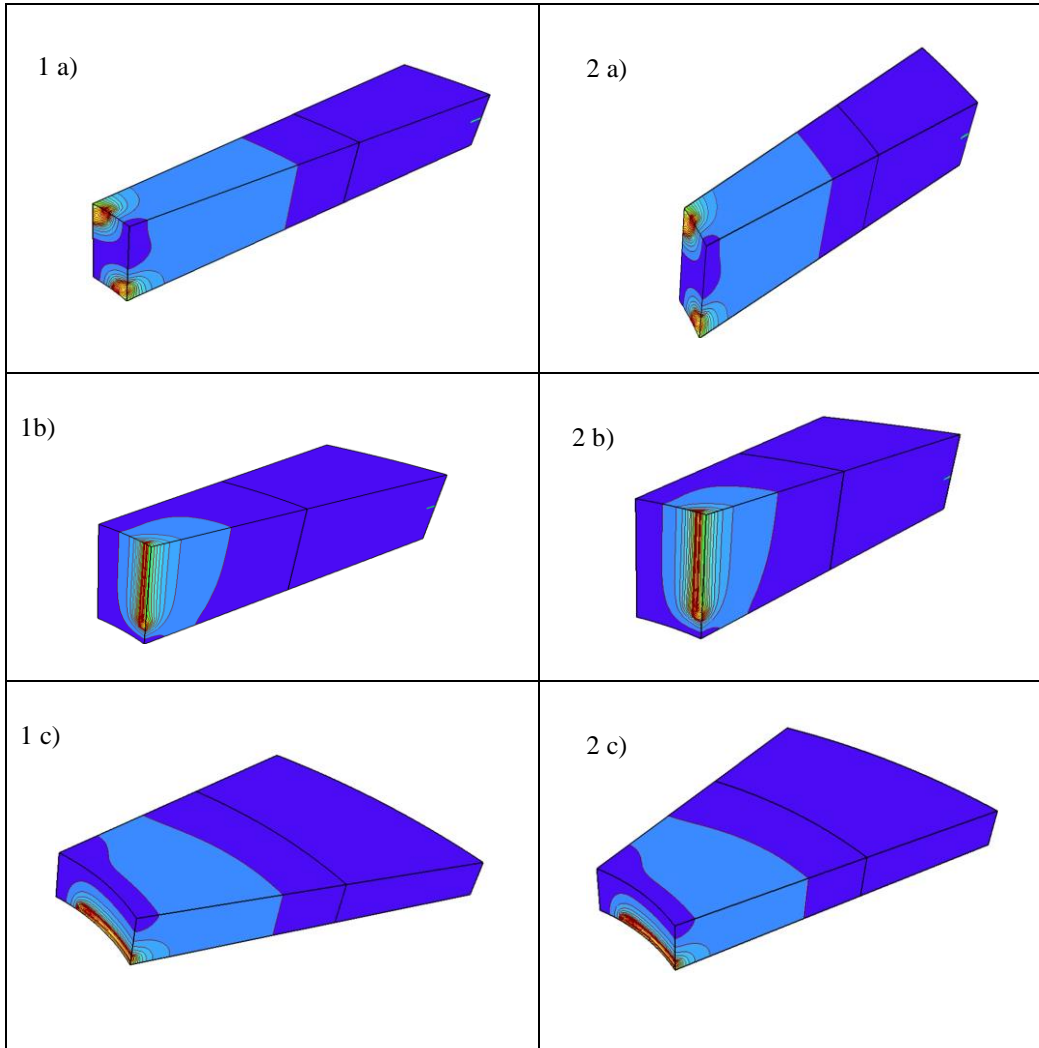

Figure 4. Maps of individual flow vectors $|\mathbf{q}|$ distribution for 3 options of the periodic cell: a) round hole perforation, b) longitudinal slot perforation, c) transversal slot perforation

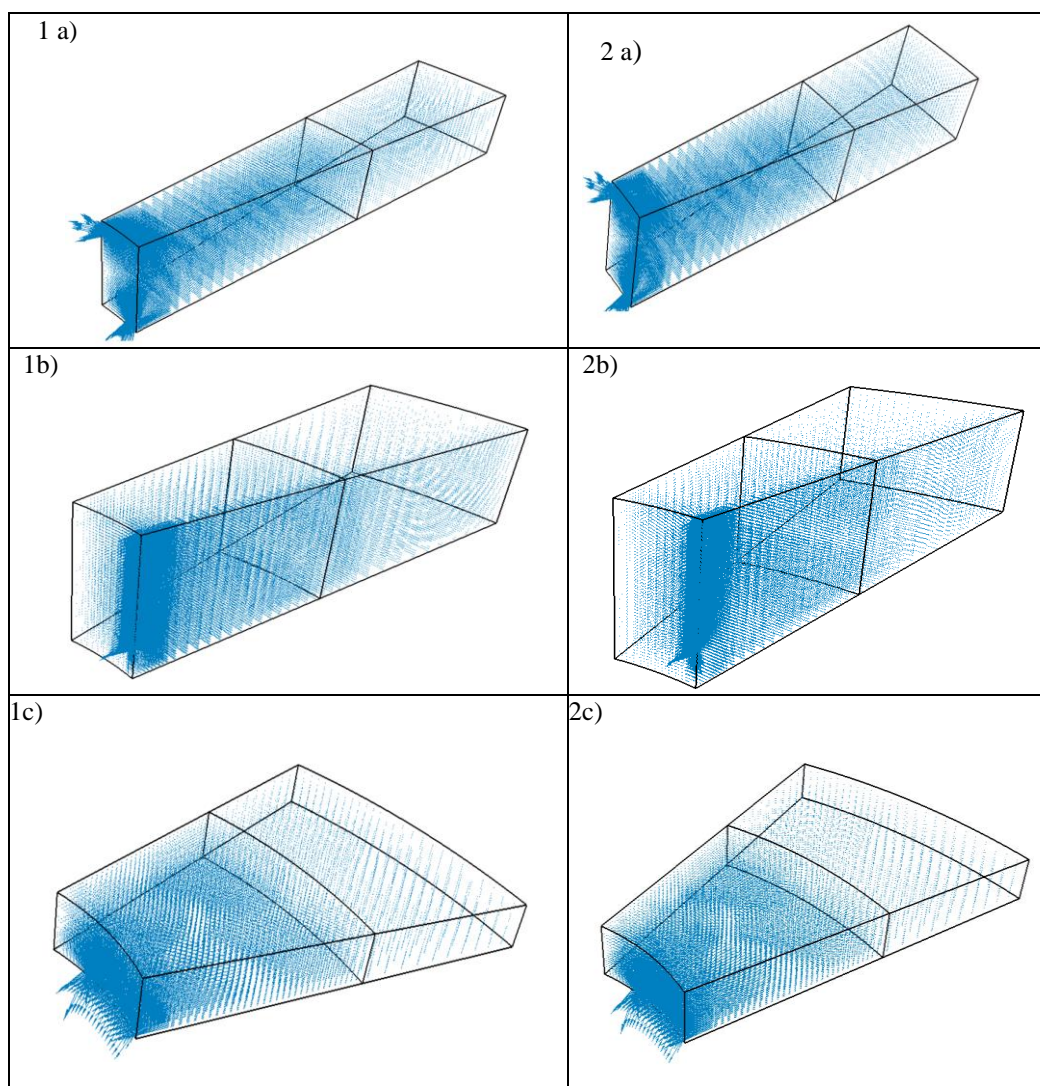

Figure 5. Flow vectors \mathbf{q} distribution for 3 options of the periodic cell: a) round hole perforation, b) longitudinal slot perforation, c) transversal slot perforation.

Table 2. Flow at the outer surface of the periodic cell (radius $R=297\text{mm}$)

perforation\set up of k type	1) $kI=0.01k=0.01\text{mm/s}$ $ \mathbf{q} \times 10^{10}[\text{mm/s}]$	2) $k=kI=1\text{mm/s}$ $ \mathbf{q} \times 10^{10}[\text{mm/s}]$
a) circular	0.08153	2.47384
b) vertical	0.08136	2.32901
c) transversal	0.08143	2.39139

Interestingly, the values of flow vectors $|\mathbf{q}|$ at the outer surface of the cell (Tab. 2), obtained for the same unit pressure value p , were very close to each other for all types of perforation, separately for each filtration setup.

Numerical modelling in the near field of the deep drilled well screen was discussed in several publications [15, 23, 25, 28]. However, the authors of the publications approach the subject differently due to complexity of the issue and diversity of situations that may occur in practice. Therefore, it is difficult to compare the results obtained in this publication with others. Most publications focus on determining the right water entrance velocity into the drilled well screen and there are many different opinions on this topic [14, 10, 12, 15, 23]. There are also many publications on new analytical and numerical models explaining and quantifying the flow behaviour in aquifer systems [28]. They often include comparisons with analytical methods.

The currently available publications certainly confirm the results obtained by the authors with regards to the occurrence of the largest values of groundwater velocity vectors near the well screen. They also confirm the pressure distribution obtained in this publication and the distribution of flow vectors although without taking into account the different types of perforation. The authors prove the above-mentioned dependencies using other tools (e.g. Fluent program) and do not analyse it at micro-scale, which is a novelty.

However, it should be noted that the approach to the issue proposed by the authors is simplified, as it is based on the Darcy's law (assumption of a laminar inflow into the well under full saturation conditions), but it can be a good, preliminary verification of empirical formulas on the basis of which the perforation of screen is selected. It should be noted, however, that in the near field of the screen, the groundwater flow may show some deviations from Darcy's law (Houben, 2015) and this will be taken into the next phase of authors research among other considerations.

Presented computational analysis of seepage fields in a close neighbourhood of the screen, where dimensions of finite elements have to be limited by slot width to 0.2 mm, and analysis is performed on a domain of periodic cell with height $\sim 10^{-2}$ m, can be seen as a micro-scale analysis, being the first step of a multi-scale analysis of the seepage problem. Obtained results can be easily used to identification of filtration properties of special finite elements by homogenization. These linear (1D) finite elements, described in ZSoil [29], can represent drilled wells in 3D FEM computational models of a macro-scale system reaching hundred of meters, see Urbański [25, 26].

4. Conclusions

The obtained results indicate that the m_f coefficient is the key parameter for selection of the opening of the deep drilled well screen. If the m_f value is maintained, shapes and a distribution of openings are of a secondary importance. The velocity and the pressure distributions are nearly identical for the studied cases. The highest flow values are observed at the centre of the screen openings and in its immediate vicinity; flow rate drops proportionally to the distance from the perforation.

The simulations with the three-dimensional FEM showed that the engineering formulas where flows to the screen depended only on the m_f coefficient had the most practical use [6, 9, 17].

REFERENCES

- [1] American Water Works Association (2014) AWWA Standard for Water Wells. ANSI/NGWA-01-14, AWWA, Denver.
- [2] Antoniou A., Smits F., Stuyfzand P., *Quality assessment of deep-well recharge applications in the Netherlands*, "Water Science and Technology: Water Supply", Vol. 17/(4)/2017, 128-132.
- [3] Bear J., *Hydraulics of Groundwater*, Mineola, Dover 2007.
- [4] Boyraz U., Kazezyilmaz-Alhan C.M., *Solutions for groundwater flow with sloping stream boundary: analytical, numerical and experimental models*, "Hydrology Research", Vol. 4(48)/2017, 258-267.
- [5] Byung-Woo K., *Effect of Filter Designs on Hydraulic Properties and Well Efficiency*, "Groundwater", Vol. S1-52 /2014, 175-185.
- [6] Castellazzi P., Martel R., Galloway D. L., Longuevergne L., Rivera A., *Assessing Groundwater Depletion and Dynamics Using GRACE and InSAR: Potential and Limitations*, "Groundwater", Vol. 54/2016, 768-780.
- [7] Delleur J.W., *Elementary Groundwater Flow and Transport Processes*, The Handbook of Groundwater Engineering, "Cushman, J. H. & Tartakovsky, D.M. (Eds.), CRC Press LLC, Florida 2016.
- [8] Gabryszewski T., Wieczysty A., *Groundwater Intakes*, Arkady, Warszawa 1985.
- [9] George R.M., *Bore Wells Vs. Open Wells: Water Crisis and Sustainable Alternatives in Kerala*, "Journal of Management and Public Policy", Vol. 7(2)/2016, 19-28.
- [10] Houben G.J., Hauschild S. I., *Numerical modelling of the near-field hydraulics of water wells*, "Hydrogeology Journal", Vol. 49/2011, 570 – 575.
- [11] Houben G.J., *Hydraulics of water wells—flow laws and influence of geometry*, "Hydrogeology Journal", Vol. 23/2015, 1633-1657.
- [12] Houben G.J., *Review: Hydraulics of water wells—head losses of individual components*, "Hydrogeology Journal", 23/2015, 1659-1675.
- [13] Mahasneh A.M., *Well Screens and Gravel Packs*, "Global Journal Of Science Frontier Research", Vol. 15-5-H/2015, 30-39.
- [14] Misstear B.D.R., Banks D., Clark L., *Water wells and boreholes*, Wiley, Chichester 2016.
- [15] Karatzas G.P., *Developments on Modeling of Groundwater Flow and Contaminant Transport*, "Water Resources Management", Vol. 31(10)/2017, 3235 -3245.
- [16] Knapik K., Bajer J., *Water Supply*, Politechnika Krakowska, Kraków 2011.
- [17] Lubowiecka T., *Mathematical model of deep drilled wells with confined aquifer and its empirical verification*, PhD dissertation, Cracow University of Technology, 1978, Cracow.



- [18] Manera D.B., Voltolini T.V., Menezes D.R., Leal de Araujo G.G., *Chemical Composition of Drilled Wells Water for Ruminants*, "Journal of Agricultural Science", Vol. 8(12)/2016, 127-132.
- [19] Mansuy N., *Water Well Rehabilitation: A Practical Guide to Understanding Well Problems and Solutions*, Layne Geosciences Inc., USA, 1999
- [20] Misstear B., Banks D., Clark L., *Water Wells and Boreholes*, John Wiley & Sons Ltd, West Sussex 2017.
- [21] Nanteza J., de Linage C. R., Thomas B. F., Famiglietti J. S., *Monitoring groundwater storage changes in complex basement aquifers: An evaluation of the GRACE satellites over East Africa*, "Water Resources Research", Vol. 52(1)/2016, 2, 42-58.
- [22] Satora S., *Konstrukcje Studni Wierconych Ujmujących Wody Podziemne z Warstw Fliszowych*, III Konferencja Naukowo – Techniczna „Błękitny San” Dubiecko, 21 – 22 kwietnia 2006.
- [23] Szanyi M.L., Hemmingsen.C.S., Yan.W., Walther, J.H., Glimberg, S.L., *Near-wellbore modeling of a horizontal well with Computational Fluid Dynamics*, "Journal of Petroleum Science and Engineering", Vol. 160/2018, 119-128, DOI: [10.1016/j.petrol.2017.10.011](https://doi.org/10.1016/j.petrol.2017.10.011).
- [24] Tkaczenko A., *Deep Drilled Wells. Part two*, Geological Publishing, Warszawa 1971.
- [25] Urbański, A., Podleś, K., *The 2D/3D method of filtration and stability analysis of a slope with dewatering wells*. Presentation on ZSoil Days 2017, https://www.zsoil.com/zsoil_day/2017/Urbanski-Podles_Wells_2D_3D.pdf.
- [26] Urbański A., *Multi-scale analysis of a flow to drainage tubes*. Presentation on ZSoil Days 2016, [http://www.zsoil.com/zsoil_day/2016/A_Urbanski_Multi scale_analysis.pdf](http://www.zsoil.com/zsoil_day/2016/A_Urbanski_Multi_scale_analysis.pdf) (access: 14.04.2018).
- [27] Wilk B. *Ultrafiltration membranes made of: polyaniline, ionic liquid and cellulose*, "Technical Transactions", Vol. 1-Ś (11)/2016, 171-187.
- [28] Yeh H.D., Chang Y.C., *Recent advances in modeling of well hydraulics*, "Advances in Water Resources", Vol. 51/2013, 27-51.
- [28] ZSoil.PC, User manual, ZACE Services Ltd., Lauzane 2017.

