

THE INFLUENCE OF MANUFACTURING OVERSIZING ON POST-WELDING DISTORTIONS OF THE FILLET WELDED JOINT

Janusz Kozak, Assoc. Prof.

Jakub Kowalski, Ms. C.

Gdańsk University of Technology, Poland

ABSTRACT

Welding process is basic joining technique in shipbuilding. Such method generated welding distortions which cause a lot of problems during the manufacturing process. In the literature it is proposed wide spectrum of suggestions for a correct estimation of welding deformation in particular angular deformation in the fillet welded T joint. In the work influence of oversizing of weld on angular distortions of joint is presented basing upon of the results of the laboratory measurements. Values determined on the basis of literature hypotheses are compared with the one obtained from the laboratory test.

Keywords: welding distortion; shipbuilding welding; welding angular distortion

INTRODUCTION

The welding process is nowadays a dominating method used to connect permanently steel structures. It consist in melting edges of the parent material of selected structure elements using a heat source, such as electric arc, plasma beam, laser, etc. Regardless of the applied method, a portion of thermal energy is introduced to the material during welding. This thermal energy initiates various processes of structure distortion, with the resultant changes in dimensions and shapes of the connected elements.

Welded T-joints compose a large portion of all joints in the metal watercraft hull structure. Their total length in a large watercraft unit can reach many kilometres. Fig. 1 shows sample joints of this type applied in the ship structure.



Fig. 1. Typical T-joints in ship structure

In the context of the above considerations, minimising post-welding distortions is of high importance and should be taken into account in both the design and production process. It can considerably simplify and accelerate the production process, as well as decrease the costs and time of possible repairs by reducing the scale of distortions. However, actions oriented on minimising post-welding distortions require information concerning mechanisms of their formation and possible scale of appearance.

A common practice among both designers of welded structures, and welders performing fillet joints in shipyards, is oversizing of welds. At the ship design stage, the weld dimension resulting from strength calculations is most frequently rounded up to an integer millimetre value. At the production stage, in turn, the design dimension is exceeded in fear that the undersized weld will not be accepted by inspection authorities. All this leads to the increase of joint distortion caused by larger amount of introduced heat, with simultaneous increase of total mass of the structure caused by excessive amounts of metal in the weld.

The paper discusses the effect of weld oversizing on the resultant angular post-welding distortions. Results of theoretical calculations making use of two analytical-empirical formulas which can be found in the literature are included, along with their confrontation with the experiment.

EXPERIMENTAL ASSESSMENT OF ANGULAR POST-WELDING DISTORTIONS OF THE HULL FILLET JOINT

To assess the effect of fillet weld oversizing in the welded T-joint on angular distortion of plating plates, a series of successively oversized joints were prepared as specimens for further tests during which process parameters and the formed distortions were recorded. The selected joint structure was a modification of a typical node of ship's structure, and the dimensions of the weld were assumed based on PRS Regulations, part II – Hull [1]. The experiment consisted in assessing the angular distortion of the joint during and after welding the bulb stiffener to the plate of normal strength ship steel, category A, for successively increasing weld dimensions “a” (Fig.1) against the nominal dimension of 4mm required by the Regulations [2].

The idea and dimensions of the examined model and the research rig are shown in Fig. 2, along with the illustration of the way in which the measurements were performed.

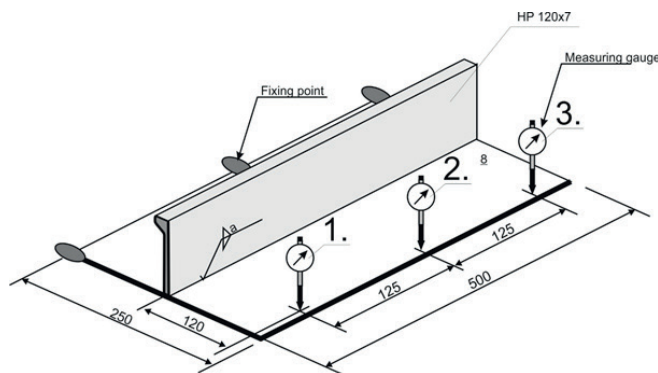

Fig.2. Scheme of the model and the research rig

During welding, the elements were immobilised using tack welds between the plating and the stiffener, while the specimen was fixed to the welding table (Fig.3). The welding process was executed following the welding procedure (WPS) for the welding method 136 – FCAW (Flux-Cored Arc Welding), approved by PRS. The welds were made by a shipbuilding welder with more than dozen-year experience and qualifications certified by the Polish Register of Shipping.

The joint preparation procedure, the weld geometry, the welding sequence, and the process parameters are given in Table I.

All basic process parameters were recorded during welding, including: arc voltage U – [V], welding current I – [A] and time of welding [min]. During laboratory tests the welding wire G464MG3Si was used as a replacement for the wire suggested in WPS: minimum yield strength 460 MPa, minimum elongation 20 %.

The angular distortion was measured using dial gauges, type M2 TOP (Fig.3).

Tab. 1. Welding Procedure Specification (WPS) [3]

Welding Procedure Specification for test joint								
Method of preparation		Oxy cutting & grinding		Material thickness		$t=7$ [mm]		
Joint preparation				Welding sequence				
Process	Run	Size of electrode [mm]	Current [A]	Voltage [V]	Current Polarity	Wire feed speed [m/min]	Weld speed [cm/min]	Heat input [kJ/cm]
PA,PB	1+	E1,2	190-240	23-27	DC(+)	6,5-10,0	16-23	9,1-19,5
Shielding gas			EN ISO 14175:M21		Gas flow rate		18-22 [l/min]	
Filler material			T464ZPMH5		Preheating temperature		Min. 10°C	



Fig.3. Model on the research rig [3]

After welding the size of the weld was measured, and these real dimensions of the weld were used for further analysis. The results of the performed tests are collated in Table 2.

Tab. 2. Results of performed tests [3]

Spec. No	weld run No 1				weld run No 1'			
	Current	Voltage	speed	gauge 2	Current	Voltage	speed	gauge 2
	I	U	v	δ_2	I	U	v	δ_2
	[A]	[V]	[m/min]	[mm]	[A]	[V]	[m/min]	[mm]
1-1	184	27,5	0,23	1,73	175	27,7	0,23	4,71
1-2	172	26,7	0,27	1,60	173	26,5	0,27	4,90
1-3	185	26,5	0,30	1,97	174	26,8	0,30	4,98
1-4	182	26,7	0,33	1,71	181	27,2	0,33	4,41
1-5	185	26,9	0,29					
2-1	190	27,4	0,22	2,72	187	27,4	0,22	5,60
2-2	189	27,4	0,25	2,68	183	27,4	0,25	5,85
2-3	188	25,7	0,19	2,35	179	26,1	0,19	5,38
2-4	180	25,3	0,20	2,50	165	25,5	0,20	5,41
2-5	165	25,8	0,20	2,31	158	26,0	0,20	4,81
3-1	174	27,5	0,21	2,15	170	27,5	0,21	5,57
3-2	185	29,5	0,25	2,32	190	29,5	0,25	5,51
3-3	188	29,4	0,25	1,89	180	29,2	0,25	5,04
3-4	187	29,2	0,26	1,90	184	29,4	0,26	5,21
3-5	188	28,9	0,26	1,62	183	29,0	0,26	4,71

where:

Spec. No – series and number of specimen in the series (1-4 – means: series one, specimen four). One series collected specimens with the same nominal dimension of the weld: 1 – 4,0 [mm], 2 – 4,5 [mm], 3 – 5,0 [mm],

Speed – v – weld speed [m/min], calculated from the measured time of welding

δ_2 – relocation of the welded plate, measured using the dial gauge at the measuring point 2 (Fig. 2) [mm],

weld run – number of weld, as indicated in WPS (Table 1)

Further analyses were performed using the results averaged over the entire series of specimens, which were recorded at the measuring points situated at the midpoint of the weld (points 2). These results were assumed not to be burdened with the joint edge effect – Table 3 – averaged values.

Tab. 3. Recalculated results of performed tests

Spec. No	weld run No 1			weld run No 1'			error $\pm\Delta\beta$ [°]
	weld size	heat input	angle	weld size	heat input	angle	
	a [mm]	qI [kJ/cm]	β [°]	a [mm]	qI [kJ/cm]	β [°]	
1-1	4,00	12,95	0,83	4,00	12,41	2,25	0,01
1-2	4,00	10,10	0,76	4,00	10,09	2,34	0,01
1-3	3,50	9,81	0,94	3,50	9,33	2,38	0,01
1-4	3,50	8,75	0,82	3,50	8,86	2,10	0,01
1-5							
2-1	5,50	13,95	1,30	5,50	13,73	2,67	0,01
2-2	4,00	12,53	1,28	4,00	12,14	2,79	0,01
2-3	4,00	14,88	1,12	4,00	14,39	2,57	0,01
2-4	3,50	13,75	1,19	3,50	12,71	2,58	0,01
2-5	4,00	12,85	1,10	4,00	12,40	2,30	0,01
3-1	5,50	13,68	1,03	5,50	13,37	2,66	0,01
3-2	5,50	13,10	1,11	5,50	13,45	2,63	0,01
3-3	4,50	13,27	0,90	4,50	12,61	2,41	0,01
3-4	5,00	12,45	0,91	5,00	12,33	2,49	0,01
3-5	5,00	12,49	0,77	5,00	12,20	2,25	0,01

where:

weld size – measured real dimension of the weld for the given run [mm],

heat input – calculated linear energy of welding for the recorded parameters U, I, and v, [kJ/cm]

β_2 – angular distortion calculated at the measuring point 2, [°],

error – accuracy of the distortion angle calculated using the total differential method for the following reading accuracies of the recorded parameters:

dial gauge accuracy: $\pm 0,01$ mm,

dial gauge reading accuracy: $\pm 0,005$ mm,

measuring accuracy of the dial position with respect to the specimen axis: $\pm 0,5$ mm,

The distortion angles at the specimen midpoint as a function of weld thickness are shown in Fig. 4, which additionally includes the regression line in the polynomial form.

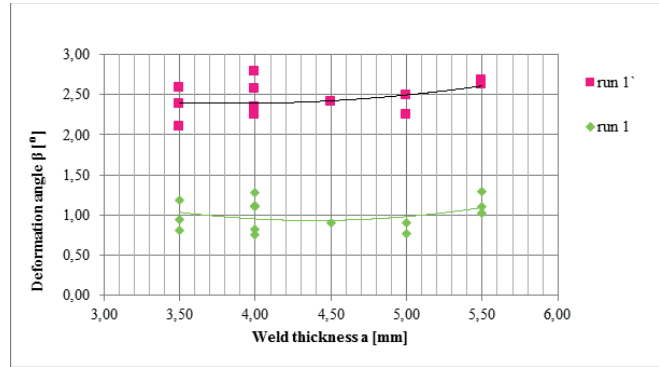

Fig. 4. Angular distortions β vs. weld thickness for both runs

THEORETICAL PREDICTION OF ANGULAR DISTORTION

Theoretical prediction of welding distortion can be performed based on analytical/empirical formulas, or can make use of the finite element method applied to thermal processes taking place during welding [4,5,6,7,8]. Modelling with the aid of the finite element method can be performed using general-purpose codes, such as FEMAP, ANSYS, SYSWELD, or dedicated programmes, such as Simufact. Welding, for instance [9]. The computer methods enable to simulate more precisely the welding process and, consequently, deliver results burdened with smaller errors. On the other hand, they are more difficult to perform than the analytical formulas and require much more detailed knowledge on the process to model it correctly and precisely.

The papers involved in seeking for analytical/empirical formulas to model welding distortions include: the works by Watanabe – Satoh [10], the Masubushi method [11], and the approach proposed by Blodgett [12]. In those methods the joint distortion angle is calculated using process parameters which are easy to obtain at the engineering calculation level. Some of those methods have been verified in relevant experiments [13].

The Watanabe – Satoh method [10] calculates the angular distortion of the fillet joint based on welding voltage and current, weld speed, electric arc efficiency, thickness of the sheet and electrode diameter. The following formula is applied:

$$\Phi = C_1 \left(\frac{I}{h\sqrt{vh}} \right)^{m+1} \cdot \exp \left(-C_2 \cdot \frac{I}{h\sqrt{vh}} \right) \quad (1)$$

$$C_1 \propto \left(\frac{\eta V}{D^{0,25}} \right)^{2,5} \quad (2)$$

$$C_2 \propto \frac{\eta V}{D^{2,25}} \quad (3)$$

where:

Φ -specimen distortion angle

I-electric current [A]

h-plate thickness [cm]

v-weld speed [cm/s]

η -heatign efficiency coefficient [-]

D-electrode diameter [cm]

V-voltage [V]

The coefficients m , $C1$ and $C2$ depend on the applied electrode. The heating efficiency coefficient for MIG method based welding ranges between 0,45 – 0,65.

The Blodgett method [12], in turn, takes into account the weld thickness a [mm], which is an important parameter from the point of view of the present analysis. Here, the angular distortion is calculated from the formula:

$$\beta_f = 0,053 \frac{b_f a^{1,3}}{t_f^2} [^\circ] \quad (4)$$

where:

b_f -plate width [mm]

a -weld thickness [mm]

t_f -thickness of the welded plate (face)[mm]

The method proposed in [14] assumes that when welding the T-joint, its angular distortion is a combined effect of plate deflection initiated by uneven transverse contraction along the plate thickness, and deflection caused by the contraction of the melted weld metal. The mechanism of angular distortion in the T-joint is shown in Fig.5.

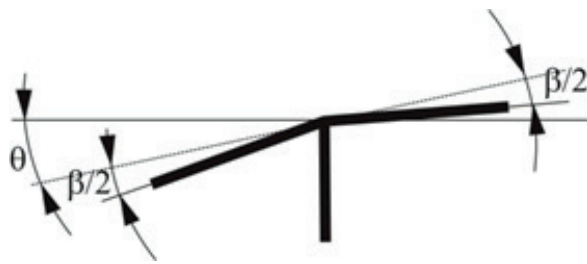

Fig.5. Mechanism of angular distortion in T-joint adopted in the method [14]

When laying the first weld, the face rotates by the angle Θ with respect to the initial position, as a result of weld metal contraction. Moreover, uneven transverse contraction along the face thickness leads to its bending by the angle β_1 with respect to the undeformed face plane. The angle Θ only slightly depends on welding parameters and its value can be assumed equal to $0,02 \div 0,024$ rad ($1,2 \div 1,5^\circ$). For the case of free deformation of the face the angle β_1 is determined, from the diagram in Fig.6, as a function of process energy per weld surface unit. In this case the calculated thickness g_0 is assumed equal to the face thickness g_p , and the calculated value of linear energy is obtained from the formula:

$$q_{l_0} = q_l \frac{2g_p}{2g_p + g_s} \quad (5)$$

where: g_p - thickness of the face in cm, g_s - thickness of the rib in cm.

The proposed approach [15] assumes that the size of angular distortions depends primarily on the ratio of thickness a of the fillet weld to the plate thickness g (Fig.7). In case of a thin plate, of $g = 6$ mm for instance, angular distortions are small because the temperature gradients across the plate thickness are small. The largest angular distortions are observed for plate thicknesses of $8 \div 10$ mm. For larger plate thickness

and small a/g ratio, angular distortions are small. The gap between the web and the plate leads to the increase of angular distortions.

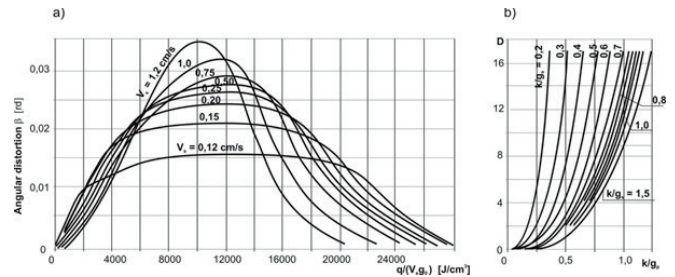

Fig.6. Nomograms: a) for assessing angular distortion β when welding butt welds and T-joints, as functions of welding conditions q , v_s , and calculated plating thickness q_0 , b) for assessing the coefficient D [14]

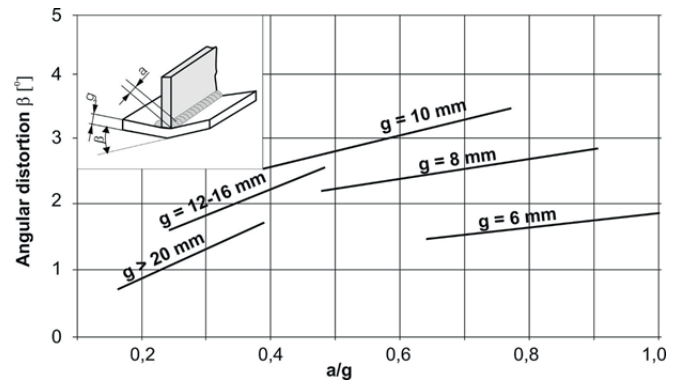

Fig.7. Angular distortions of plates caused by fillet welds [15]

The angular distortions calculated using the above method for the averaged data recorded in the experiments for weld dimensions $a=3,75$ [mm], $4,20$ [mm] and $5,10$ [mm] were equal to, respectively: $2,25^\circ$, $2,32^\circ$ and $2,47^\circ$.

Tab. 4. Compares experimental results with those calculated based on [15]

Lp.	a_b	β_{exp}	β_{obbl}
	[mm]	[$^\circ$]	[$^\circ$]
1	3,75	2,27	2,25
2	4,2	2,58	2,42
3	5,1	2,49	2,47

The data in Tab. 4 reveal that the nature of weld distortion angle changes calculated using the procedure given in the literature [15] differs from that recorded experimentally. While the theoretically calculated distortion angles are in linear relation with the weld size, the relation recorded experimentally is not linear.

CONCLUSIONS

Predicting welding distortions is an important part of structure design and building. When welding, arbitrary weld oversizing by as little as a few tenths of a millimetre may lead to distortion increase by over ten percent.

For real weld thicknesses $a = \{3,75 \text{ mm}; 4,20 \text{ mm}; 5,10 \text{ mm}\}$, the angular distortions which were experimentally recorded in successive tests of the examined joint were equal to $\beta \approx \{2,27^\circ; 2,58^\circ; 2,49^\circ\}$. These results reveal that weld oversizing leads to the increase of angular welding distortions. However, this relation is not linear. Correctness of formulas, in particular for larger weld thicknesses ($a \geq 5 \text{ mm}$), requires further experimental examination. For two-side multi-pass fillet welds, an additional factor which can affect angular distortions and which is not taken into account in the above quoted analytical formulas is the sequence of laying of successive weld metal layers (runs). Future numerical analyses, followed by their further experimental verification, would allow to model the effect of welding sequence and weld oversizing on the size of the resultant angular distortions.

Comparing angular distortions β recorded experimentally with those obtained from calculations reveals that the quoted engineering method slightly underestimates the angular welding distortion, and that the obtained theoretical relation is linear.

The experimental results were recorded on specimens welded in laboratory conditions. Consequently, the behaviour of the full-size structure and the effect of scale in selected calculation methods could not be taken into account and need further examination.

BIBLIOGRAPHY

1. PRS Regulations, Principles for Welding Procedure Qualification Tests, Publication no. 74/p, 2007 (in Polish).
2. PRS Regulations, pt II Hull, 2014 (in Polish).
3. Wierzbička : Overview and verification of formulas used to estimate angular distortions in a T-joint. Diploma thesis, Gdansk University of Technology, Faculty of Ocean Engineering and Ship Technology, 2014 (in Polish).
4. K. Ferenc, J. Ferenc: Welded structures – Joint design, Wydawnictwo Naukowo-Techniczne, Warsaw 2000 (in Polish).
5. Czajkowski H., Jakubiec M., Lesiński K., Technology of welded structures, Warsaw 1987 (in Polish).
6. Sędek P., Welding stresses and distortions, [in:] Engineer's guidebook, Welding, t. I, ed. J. Pilarczyk, Warsaw 2003, pp. 559 -597 (in Polish).
7. Gourd L.M., Principles of welding technologies, transl. by N. Gawroniak, Warsaw 1997 (in Polish).

8. Predictive formulae for weld distortion – a critical review, Abington Publishing, 1999, ISBN 185573 444 3.
9. http://www.simufact.de/en/solutions/sol_weld.html (05.04.2014).
10. G. Jung, Plasticity-Based Distortion Analysis For Fillet Welded Thin Plate T-Joints, Dissertation, The Ohio State University 2003.
11. Ye Zhou, Analysis of Welding Distortions using Qualitative and Semi-quantitative Techniques, The University of British Columbia, 1998.
12. R.W.O'Brien, Predicting weld distortion in the design of automotive components, Durham theses, Durham University (2007). Available at Durham E-Theses Online: <http://etheses.dur.ac.uk/2462/>.
13. Kozak, J.Kowalski, Problems of Determination of Welding Angular Distortions of T-fillet Joints in Ship Hull Structures, Polish Maritime Research, ISSN: 1233-2585, 2015, vol.22, No2(86), 79-85
14. Czajkowski H., Jakubiec M., Lesiński K., Technology of welded structures, Warsaw 1987 (in Polish).
15. Engineer's guidebook: welding. T. 1., Wydawnictwa Naukowo-Techniczne, Warsaw 2003 (in Polish).

CONTACT WITH AUTHOR

Janusz Kozak
Jakub Kowalski

Gdansk University of Technology
Faculty of Ocean Engineering and Ship Technology
Naurutowicza 11/12 St.
80-233 Gdansk,
Poland

phone: +48 58 3471735
e-mail: kozak@pg.gda.pl