

The noise macromodel of an optocoupler including $1/f^\alpha$ noise source

B. STAWARZ-GRACZYK*, J. CICHOSZ and A. KONCZAKOWSKA

Faculty of Electronics, Telecommunications and Informatics, Department of Optoelectronics and Electronic Systems, Gdańsk University of Technology, 11/12 G. Narutowicza St., 80-952 Gdańsk, Poland

Abstract. The course of design of an optocoupler's PSpice macromodel including noise sources is described. The PSpice macromodel is proposed for the low frequency range. The PSpice model of a MOSFET transistor was applied as the noise source type $1/f^\alpha$ in an optocoupler PSpice macromodel. In the enhanced macromodel the value of an exponent α can be changed in the range of 0.8–1.25.

Key words: optoelectronic devices, $1/f^\alpha$ noise, noise macromodel of optocouplers.

1. Introduction

Optocoupler devices are very often applied in electronic systems, e.g. in telecommunications systems. Their noise properties, especially in a low frequency range, can substantially affect operation of electronic systems. An optocoupler device is an infrared emitting diode which is optically coupled with a photodetector. The noise properties of optocoupler devices are discussed in literature, for example in [1–6]. The research carried out by authors on CNY 17 type optocoupler devices were focused on a determination of their noise properties. The device is a pair consisting of a gallium arsenide infrared emitting diode (LED) optically coupled with a silicon npn phototransistor. The results of noise measurements were presented in [6–11]. They allow to draw following conclusions:

1. The intensity of LED noise is negligibly low, it does not influence an output noise of optocoupler.
2. The noise of the optical channel does not influence an output noise of optocoupler.
3. The properties of noise of optocoupler device in a low frequency range depend on noise sources existing in the phototransistor.
4. The estimated spectra of inherent noise of the optocouplers have different slopes in the range of noise (the value of an exponent $1/f^\alpha$ is between 0.8 and 1.25).

To summarize, in a noise model of an optocoupler a noise source of $1/f^\alpha$ type (with the possibility of changing the value of an exponent α) should be included.

The noise properties of an optocoupler can be described by available in PSpice program model of an optocoupler [12, 13]. In this model a thermal, shot and $1/f^\alpha$ (with $\alpha = 1$) noise sources are contained.

The aim of the paper is to present an enhanced PSpice macromodel of an optocoupler with a $1/f^\alpha$ noise source, including possibility of changing the value of an exponent α , valid for a low frequency range. The design principles of this

macromodel were based on the PSpice macromodel of MOSFETs [12]. It means that in the enhanced PSpice macromodel of an optocoupler device the $1/f^\alpha$ noise source with possibility of changing the value of an exponent α has to be located in a phototransistor.

2. Noise sources in an optocoupler

The processes of modelling the noise of optocouplers and of transistors were presented in literature, for example in [12–17]. At the beginning of the course of a design of an enhanced optocoupler PSpice macromodel, the noise macromodels of an optocoupler (available in the PSpice program) and their properties will be presented.

The noise macromodels of an optocoupler are available for example in the Micro-Cap program (eight different macromodels) and in the ICAPS program (two different macromodels). In Fig. 1 an optocoupler macromodel – ON22, available in the Micro-Cap program, is shown [12]. In the macromodel the source H1 represents a linearly dependent voltage source controlled by diode's current, the source G1 represents a linearly dependent current source controlled by voltage.

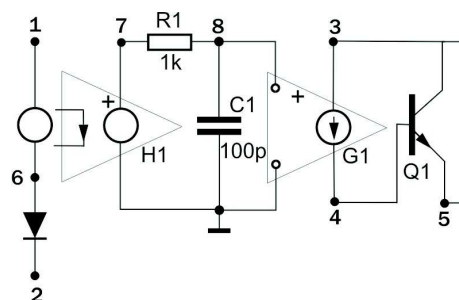

Fig. 1. The macromodel of an optocoupler available in the Micro-Cap program after Ref. 12

The model of LED is described as follows: MODEL LED D ($N = 2.50$, $RS = .0001$, $CJO = 40PF$, $IS = 306E-12$).

*e-mail: bstawarz@eti.pg.gda.pl

The relationships describing noise sources existing in this model are as follows:

- thermal noise of parasitic series resistance RS :

$$i_{n1}^2 = \frac{4 \cdot k \cdot T}{RS/area} \quad (1)$$

- shot noise and $1/f$ noise of the LED, produced by diode current i_d :

$$i_{n2}^2 = 2 \cdot q \cdot i_d + \frac{KF \cdot i_d^{AF}}{f}. \quad (2)$$

The model of a bipolar transistor is described as follows: MODEL QOPTO NPN ($IS = 7.0E-12$, $NF = 1.23$, $CJC = 4PF$, $CJE = 14PF$, $TF = 10NS$, $TR = 10NS$, $BF = 500$, $BR = 10$, $IKF = 750MA$, $VAF = 40$). The relationships describing noise sources existing in this model are as follows:

- thermal noise of parasitic collector resistance RC :

$$i_{nRC}^2 = \frac{4 \cdot k \cdot T}{RC/area} \quad (3)$$

- thermal noise of parasitic base resistance RB :

$$i_{nRB}^2 = \frac{4 \cdot k \cdot T}{RB} \quad (4)$$

- thermal noise of parasitic emitter resistance RE :

$$i_{nRE}^2 = \frac{4 \cdot k \cdot T}{RE/area} \quad (5)$$

- shot noise and $1/f$ noise of a bipolar transistor, produced by a base current i_b :

$$i_{nb}^2 = 2 \cdot q \cdot i_b + \frac{KF \cdot i_b^{AF}}{f} \quad (6)$$

- shot noise of a bipolar transistor produced by a collector current i_c :

$$i_{nc}^2 = 2 \cdot q \cdot i_c. \quad (7)$$

The list of symbols used in relations (1)–(7) is presented below:

$k = 1.38 \cdot 10^{-23}$ [$W \cdot s/K$] – Boltzmann's constant,

T [K] – ambient temperature,

$q = 1.6 \cdot 10^{-19}$ [C] – electron charge,

KF and AF – $1/f$ noise source parameters (KF – a coefficient and AF – an exponent related to current i_b).

In the library of the PSpice values of KF and AF for diodes and for bipolar transistors are usually equal to 0 and 1, respectively [13]. The exponent AF is applied for changing the base current i_b shape. That means that in this case the $1/f$ noise source is not taken into account in the optocoupler's model ($KF = 0$). The value of KF can be changed manually and in this case (if it is different from 0) the $1/f$ noise source can exist in the model.

In the presented above PSpice macromodel of an optocoupler device there is available the $1/f$ noise source, but not the $1/f^\alpha$ noise source with possibility of changing the value of an exponent α . The PSpice model of a MOSFET transistor contains the searched $1/f^\alpha$ noise source. We propose to apply this model as a $1/f^\alpha$ noise source in an enhanced PSpice macromodel of optocoupler devices.

The MOSFET transistor model – MTP15N06L (semi-empirical short-channel model) was chosen to develop a PSpice macromodel of optocoupler devices including the $1/f^\alpha$ noise source [12]. For the MOSFET transistor model the following parameters were selected: $LEVEL = 2$, $NLEV = 2$. The relationships describing noise sources existing in the PSpice model of a MOSFET transistor are as follows [12, 13]:

- thermal noise of parasitic drain resistance RD :

$$i_{nRD}^2 = \frac{4 \cdot k \cdot T}{RD} \quad (8)$$

- thermal noise of parasitic gate resistance RG :

$$i_{nRG}^2 = \frac{4 \cdot k \cdot T}{RG} \quad (9)$$

- thermal noise of parasitic source resistance RS :

$$i_{nRS}^2 = \frac{4 \cdot k \cdot T}{RS} \quad (10)$$

- intrinsic shot noise:

$$i_{ns}^2 = \frac{8 \cdot k \cdot T \cdot g_m}{3} \quad (11)$$

- $1/f^\alpha$ noise:

$$i_{nf}^2 = \frac{KF \cdot g_m^2}{C_{OX} \cdot W_{eff} \cdot L_{eff} \cdot f^{AF}} \quad (12)$$

where KF and AF are $1/f^\alpha$ noise source parameters (a coefficient KF and an exponent AF related with frequency f), g_m – transconductance [mS], C_{ox} – the gate oxide capacitance per unit area [nF/cm²], L_{eff} – effective channel length [m], W_{eff} – effective channel width [m].

It is worth to stress that the same symbols (KF and AF) are used as parameters for a $1/f$ noise source in the PSpice models. However, in the macromodel ON22 an AF is used as an exponent of a current, but in the model MTP15N061 an AF is used as an exponent of a frequency.

3. The noise macromodel of an optocoupler

The process of development of an optocoupler's macromodel in the PSpice including $1/f^\alpha$ noise source began from designing of a simple circuit shown in Fig. 2 [12, 13, 18].

In the presented circuit the optocoupler macromodel is contained within the dotted frame. In this circuit it is impossible to control the value of an exponent α , because it is equal to one. It is only possible to include the $1/f^\alpha$ noise ($\alpha = 1$) by setting – for a LED and a transistor – the value of KF other than 0.

In this model values of transresistance (r_{H1}) of source $H1$ as well as transconductance (g_{G1}) of source $G1$ were selected using the relation (12) and the current gain β for transistors and CTR (Current Transfer Ratio) for optocouplers as the results of measurements (13):

$$CTR = r_{H1} \cdot g_{G1} \cdot \beta \cdot 100[\%] \quad (13)$$

$$CTR = \frac{i_c}{i_d} \cdot 100[\%] \quad (14)$$

where: i_d – current of optocoupler LED diode, i_c – collector current of optocoupler transistor caused by i_d .

In the circuit presented in Fig. 2 a few specified simulations were carried out. The results are presented in Fig. 3 and in Fig. 4. The aim of simulations was to estimate the output noise in the optocoupler's macromodel for four cases:

1. $1/f^\alpha$ noise sources of a LED and of a transistor were not taken into account, ($KF = 0$); see result in Fig. 3,
2. $1/f^\alpha$ noise sources of a LED and of a transistor were taken into account, ($KF = 10^{-16}$, $AF = 1$, and AF is a current exponent); see results in Fig. 4,
3. $1/f^\alpha$ noise source of LED was taken into account, ($KF = 10^{-16}$, $AF = 1$, and AF is a current exponent) whereas $1/f^\alpha$ noise source of transistor was not; see result in Fig. 3,
4. $1/f^\alpha$ noise source of transistor was taken into account, ($KF = 10^{-16}$, $AF = 1$, and AF is a current exponent) whereas $1/f^\alpha$ noise source of diode was not; see result in Fig. 4.

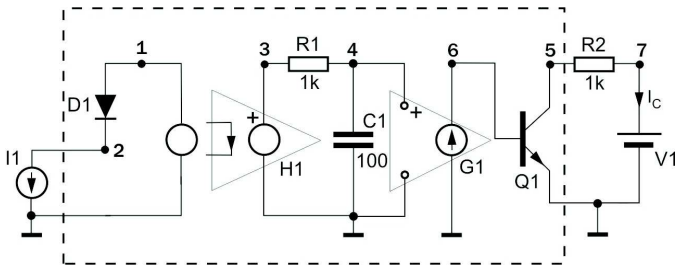

Fig. 2. The circuit with the noise macromodel of an optocoupler with the exponent α equal to one

The spectrum of an output noise of the optocoupler's macromodel presented in Fig. 3 has a flat characteristic in the frequency range from $1Hz$ to $10kHz$ (white noise). The bandwidth is limited by a lowpass filter $R_1 C_1$ (Fig. 2). This is valid for cases, when the $2/f^\alpha$ noise source of a transistor does not exist in the macromodel. If the $1/f^\alpha$ noise source is simulated in a transistor, the noise spectrum of the optocoupler's macromodel in the frequency range from $1Hz$ to $10kHz$ has exactly an $1/f$ slope (Fig. 4).

To estimate the influence of a level of diode's noise on optocoupler's noise the appropriate PSpice simulations were carried out and were referred to the cases when the diode generated small noise (KF equal to 10^{-16}) and large noise (KF equal to 10^{-2}) for typical operation of a transistor. The

resulting characteristics of an output noise of optocoupler are identical with the presented in Fig. 3.

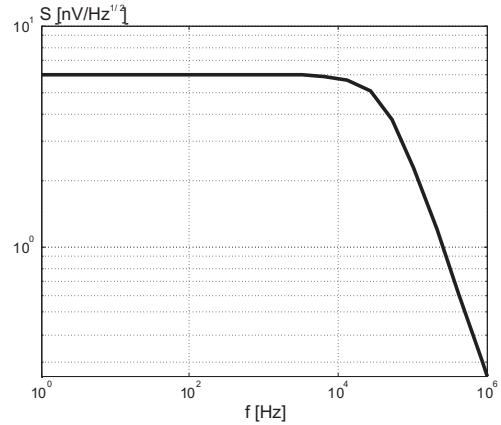

Fig. 3. The output noise of an optocoupler for cases:
– without $1/f^\alpha$ noise source in a LED and in a transistor,
– with $1/f^\alpha$ noise source existing only in a LED

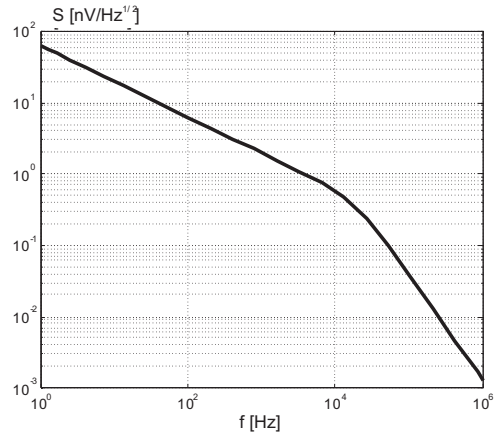

Fig. 4. The output noise of optocoupler for cases:
– with $1/f^\alpha$ noise sources of LED and of transistor existing in both devices,
– with $1/f^\alpha$ noise source existing only in a transistor

As we see from the results of the simulation the $1/f^\alpha$ type noise source included in a diode does not influence the output noise of an optocoupler. Only the $1/f^\alpha$ type noise source included in a transistor is visible in an output noise of an optocoupler. These facts confirm that the properties of this macromodel follow the results of noise measurements [6, 7].

4. The enhanced noise macromodel of an optocoupler

As it was mentioned above, we proposed to apply the PSpice model of MOSFET transistor (MTP15N06L) as the $1/f^\alpha$ noise source with possibility of changing the value of exponent α in the enhanced noise macromodel of optocoupler. In the PSpice macromodel ON22 an additional $1/f^\alpha$ noise source (macromodel MTP15N06L) is connected to the input (the base) of the transistor. The circuit with enhanced optocoupler's macromodel is presented in Fig. 5. The optocoupler's

macromodel with possibility of changing the value of an exponent α is contained within the dotted frame. The text file of optocoupler's enhanced macromodel in PSpice is presented in Appendix A1. In this enhanced macromodel the $1/f^\alpha$ noise sources (α equal to 1) existing in the LED and transistor are disconnected.

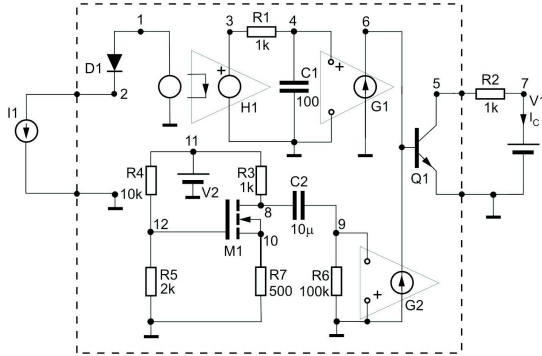

Fig. 5. The circuit with enhanced macromodel of an optocoupler with $1/f^\alpha$ noise source

For this enhanced macromodel three simulations, for values of exponent α equal to 0.8, 1.0 and 1.25, were carried out. The results of these calculations are shown in Fig. 6.

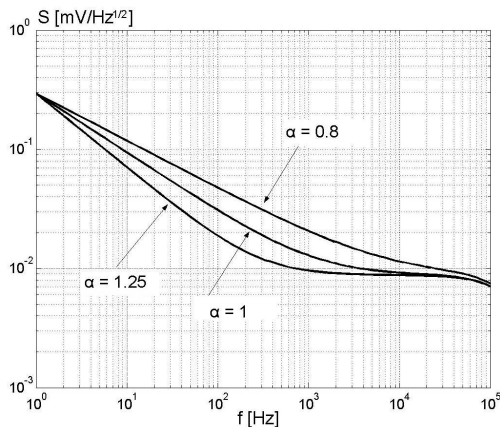

Fig. 6. The output noise of an optocoupler for different values of exponent α

It was proved that the noise macromodel works properly, the output noise of an optocoupler depends on the value of exponent α which can be changed within a wide range. In the paper the results of simulation carried out only for the values of exponent α within the range from 0.8 to 1.25 was presented.

5. Conclusions

In the paper the course of designing the noise PSpice macromodel of an optocoupler was presented. All simulations were carried out with the Micro-Cap 9.0. program. The noise characteristics presented in Fig. 6 confirm that the enhanced noise macromodel of an optocoupler works properly, and its results comply with the experimental ones. Presented macromodels will be further developed to receive the macromodel of an

optocoupler with the Random Telegraph Signal noise (RTS noise) source.

Appendix

A1. The text file of the program including the PSpice macromodel of an optocoupler

```

C1 4 0 100P
C2 9 8 10U
D1 1 2 1N3491
G1 0 6 4 0 0.02
G2 0 6 0 9 1
H1 3 0 VH1 {2}
I1 2 0 DC 1M AC 0 0 PULSE 0 0 0 0 0 0 0
M1 8 12 10 10 MTP15N06L
Q1 5 6 0 2N2222
R1 4 3 1K
R2 5 7 1K
R3 8 11 1K
R4 12 11 10K
R5 0 12 2K
R6 0 9 100K
R7 0 10 500
RG1 4 0 1G ;added by G1
RG2 9 0 1G ;added by G2
V1 7 0 12
V2 11 0 10V
VH1 0 1 0 ;added by H1
.MODEL 1N3491 D (BV=50 CJO=1.663921N
IS=13.460386F M=1.022738 N=978.086216
+ TT=6.035286U VJ=700M)
.MODEL 2N2218 NPN (BF=112.569971 BR=171.222M
CJC=36.643715P CJE=42.423882P
+ IKF=314.794955M IKR=476.23511 IS=10.016998F
ISC=2.934123P ISE=955.181897F
+ ITF=10.287061M MJC=558.065918M MJE=642.887486M
NE=1.612832 NF=979.989695M
+ RE=668.817453M TF=407.084476P TR=2.301168U
VAF=100 VJC=700M VJE=700.000001M
+ VTF=9.999998 XTF=500.021035M)
.MODEL MTP15N06L NMOS (LEVEL=3 AF=1.25
CBD=1.419727N CGDO=429.102189P
+ CGSO=2.398235N GAMMA=0 JS=10N
KF=0.000000000001 KP=20U L=2U
+ LAMBDA=109.675148F MJSW=330.00001M NLEV=2
NSUB=0 PBSW=800.00001M
+ PHI=600.00002M RDS=60MEG TOX=0 TPG=1 UO=600
VTO=1.338153 W=353.425914M);
parameter AF can be chosen arbitrarily
    
```

REFERENCES

- [1] M. Jevtic, "Low frequency noise as a tool to study optocouplers with phototransistors", *Microelectronic Reliability* 44, 1123–1129 (2004).
- [2] A. Bandyopadhyay and M. J. Deen, "Photodetectors for optical fiber communications", *Photodetector and Fiber Optics*, 307–368 (2001).

- [3] Z. Bielecki and A. Rogalski, *Detection of Optical Signals*, WNT, Warsaw, 2001 (in Polish).
- [4] N.B. Lukyanchikova, "General results of investigation of the excess noise in opto-electronic devices and their application for improving the device performance", *Proc. of EDMO'95*, 32–37 (1995).
- [5] J. Xu, D. Abbot, and Y. Dai, "1/f, g-r and burst noise used as a screening threshold for reliability estimation of optoelectronic coupled device", *Microelectronics Reliability* 40, 171–178 (2000).
- [6] A. Konczakowska, J. Cichosz, A. Szewczyk, and B. Stawarz, "Analysis of noise properties of the optocoupler device", *Opto-Electronic Review* 15 (3), 149–153 (2007).
- [7] A. Konczakowska, J. Cichosz, A. Szewczyk, and B. Stawarz, "Identification of optocoupler devices with RTS noise", *Fluctuation and Noise Letters* 6 (4), L395–L404 (2006).
- [8] A. Konczakowska, J. Cichosz, S. Galla, and B. Stawarz, "Noise of optoelectronic coupled devices", *Proc. SPIE. Noise and Information in Nanoelectronics, Sensors, and Standards II*, 5470, 566–572 (2004).
- [9] A. Konczakowska, J. Cichosz, and B. Stawarz, "Statistical properties of low frequency noise of optoelectronic coupled devices", *Proc. SPIE Noise and Information in Nanoelectronics, Sensors, and Standards II* 5470, 375–384 (2004).
- [10] A. Konczakowska, J. Cichosz, and B. Stawarz, "RTS noise in optoelectronic coupled devices", *Proc. 18th Inter. Conf. Noise and Fluctuations ICNF'2005*, 669–672 (2005).
- [11] A. Konczakowska, J. Cichosz, and A. Szewczyk, "A new method for identification of RTS noise", *Bull. Pol. Ac.: Tech.* 54 (4), 457–460, (2006).
- [12] *Micro-Cap 9, Electronic Circuit Analysis Program Reference Manual*, Spectrum Software, www.spectrum-soft.com (2007).
- [13] *Working with Model Libraries*, Intusoft, www.intusoft.com (2001).
- [14] W.N. Cheung, P.J. Edwards, and T. Zhang, "Modelling of sub-shot noise optocouplers using relative noise difference", *Signal, Systems, and Electronics, Proc. URSI International Symposium, ISSSE'95*, 517–520 (1995).
- [15] W.N. Cheung and P.J. Edwards, "Simulation of noise characteristics in optical devices using PSpice", *Int. J. Electronics* 76 (4), 627–632 (1994).
- [16] W.N. Cheung and P.J. Edwards, "Modelling and analysis of quantum noise suppressed optocoupler amplifiers", *10th Int. Conf. on Integrated Optics and Optical Fibre Communication* 26–30 (1995).
- [17] H. Shichman and A. Hodges, "Modelling and simulation of insulated-gate field-effect transistor switching circuits", *IEEE J. Solid-State Circuits* SC-3, 285–289 (1968).
- [18] B. Stawarz-Graczyk, J. Cichosz, and A. Konczakowska, "Noise macromodel of optocoupler including $1/f^\alpha$ noise sources", *Proc. 6th Polish Conference of Electronics, KKE' 2*, 461–466 (2007), (in Polish).