

The system for remote monitoring of a vertical axis wind farm

Grzegorz Kostro*, Filip Kutt†, Michał Michna‡, Roland Ryndzionek§ and Łukasz Sienkiewicz¶

Faculty of Electrical and Control Engineering

Gdansk University of Technology

Gdansk, Poland

Email: *grzegorz.kostro@pg.edu.pl, †filip.kutt@pg.edu.pl, ‡michal.michna@pg.edu.pl,
§roland.ryndzionek@pg.edu.pl, ¶lukasz.sienkiewicz@pg.edu.pl

Abstract—The article presents a system for remote monitoring of working parameters of a wind turbine with a vertical axis. The monitoring system was built using a Raspberry PI 3 micro-computer with the Raspbian operating system and a MicroDAQ E2000 measuring card. The developed system enables monitoring the power output of the generator, torque on the turbine shaft, turbine speed and wind speed. The values of the monitored parameters are saved in the internal memory of the measuring device. By using a microcomputer, it is possible to view and share measurement results remotely.

Index Terms—vertical axis wind turbine, permanent magnet synchronous generator, measurement working parameters, remote monitoring

I. INTRODUCTION

The dynamic development of prosumer energy market in recent years has influenced the development of new solutions within renewable energy systems. If prosumer micro installations are relying on solar systems, it is possible to use structures with limited diversity and relatively well-known technology. In case of solutions using wind turbines, it is possible to use structures with a relatively large diversity. In particular, this applies to micro installations with vertical axis wind turbines (VAWT) [1], [2].

Due to the variety of construction solutions of the VAWT power plant [3], it is necessary to verify the adopted assumptions in the design and construction of turbines [4], [5]. The verification can be carried out under controlled conditions in the wind tunnel. Such tests enable determination of the parameters of a given turbine in an unambiguous way. Unfortunately, due to the dimensions of some designs, it is necessary to carry out the verification using a portable measuring system. Such a system allows for measuring wind conditions and turbine performance parameters such as mechanical power on the shaft and electric power of the generator [6]–[10].

Research conducted directly at the wind farm site also allows assessment of wind conditions for a given location. Because prosumer microgeneration is considered, i.e. with a power not exceeding 50 kW, while the vast majority oscillates around 10 kW, the dimensions of such a turbine are not significant (Fig.1). In such case, we are dealing with installations that can be converted without significant costs.

Due to that fact, we want to install such a system in a place where the best wind conditions prevail. The access to the



Fig. 1. Vertical axis wind turbines.

turbine and measuring system, at the optimal location in terms of wind conditions, may be hindered. The lack of power from the power system is a common difficulty as well. This means that it is necessary to design and build a measurement system that can collect measurement data in a relatively long time and operate without access to power from the power system.

This research project has been conducted in the frame of development a low-speed permanent magnet synchronous generator prototype. The whole project realization (concept, design, engineering documentation, building, and testing) of the prototype has been described in details in [11]. The rated data of the designed generator are the following:

- Power - 15 kVA,
- Voltage - 400 V (Y),
- Rotational speed - 93.75 rpm.

II. ASSUMPTIONS OF THE PROJECT

The measuring system should meet a number of requirements. First, it is necessary to measure the power of the turbine shaft. The turbine in the analyzed case works for an island power system. This means that the wind farm's generator works on the local active load in the form of a three-phase, variable resistor.

The measuring system has been equipped with a torque converter and a speed measurement system (Fig. 2). Owing to the method of fastening the torque transducer, and in particular, due to the construction of the couplings, this measurement was subject to considerable interference. Thus, a different solution for measuring the mechanical power on the shaft has been developed [12]. This measurement is an indirect measurement and is based on the measurement of electrical power at the output of tested generator, a known map of generator efficiency for various rotational speeds and different values of current at a resistive load (Table I).

Since a significant part of the measuring transducers intended for measuring the power in an AC system is based on a small variation of the voltage frequency, it was necessary to use a system that could accurately measure power in a wide range of frequency variations.

The measurement of wind conditions was another issue. In the case of the developed system, the speed of the wind was the measured quantity. This was done based on the signal from the rotary-pulse transducer installed in the anemometer (one pulse per revolution, the 1 Hz frequency corresponds to a wind speed of 1 m/s).

Due to the requirement of power being fed to the measurement system from local energy reservoirs, it was necessary to develop a dedicated power supply and charging system. Two accumulators with a nominal voltage of 12 V and a capacity of 55 Ah were used as reservoirs. Such containers allowed powering the system for 36 hours. After this time, discharged batteries were delivered for charging and re-installed after charging. Due to the high variability of the wind speed and the voltage value at the generator terminals depending on it, it was not possible to use electricity from the generator output to recharge the batteries. Authors believe that in order to avoid the necessity of recharging the batteries, the developed system should be equipped with a charging system using photovoltaic cells.

The last requirement was the ability of remote access to measurements data to monitor and transfer their values to a computer connected to the Internet. The Raspberry PI 3B microcomputer, with a modem and a VNC server installed, was used for this task.

III. DATA ACQUISITION SYSTEM

The measurement system was developed using the Micro DAQ E2000 device, equipped with analog and digital inputs. Seven analog and two digital inputs were used for the measurement. Six analog inputs were connected to LEM type transducers (three current/voltage converters and three voltage/voltage converters). The signal from the torque measurement sensor (mounted between the wind turbine and the generator) was connected to the seventh analog input. Signals from an inductive sensor (used to determine the generator's rotational speed and generator's voltage frequency) and a sensor for measuring the wind's speed were connected to the digital inputs. The view of a wind farm monitoring system with a VAWT is presented in Fig. 2.

TABLE I
EFFICIENCY OF THE GENERATOR AS A FUNCTION OF THE ROTATIONAL SPEED AND LOAD CURRENT FOR $\cos\phi = 1$

Velocity [rpm]	I [A]				
	5	10	15	20	25
10	76%	53%	27%		
20	86%	76%	63%	48%	30%
30	89%	83%	75%	65%	53%
40	89%	86%	80%	73%	64%
50	89%	88%	83%	78%	71%
60	89%	89%	85%	81%	75%
70	88%	89%	87%	83%	78%
80	88%	89%	88%	85%	80%
90	87%	89%	88%	86%	82%
100	86%	89%	89%	86%	83%

The block diagram explaining the role of particular components of the system is located in Fig. 3.

Analog inputs of the Micro DAQ E2000 card had a limited voltage range (± 10 V). In a real system, the measured signals were currents and voltages with higher values than the input range of the card. Therefore it was necessary to convert the current signal to the voltage signal and reduce its amplitude to the level accepted by the measurement card. The LEM transducers were used to achieve those requirements.

Authors assumed that the currents, voltages, mechanical torque, rotation speed, and wind speed were measured by the elaborate system. The connection of the measured signals to the card inputs is presented in the Fig. 4.



Fig. 2. System for monitoring the operation parameters of a wind farm with a VAWT.

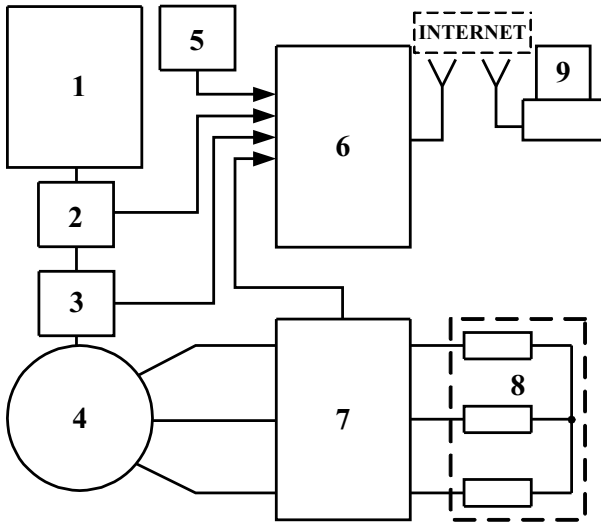

Fig. 3. The block diagram of the system presented in Fig. 2: 1 – vertical axis wind turbine, 2 – torque meter, 3 – rotation speed sensor (inductive sensor), 4 – low speed permanent magnet synchronous generator, 5 – wind speed sensor, 6 – Micro DAQ E2000 with microcomputer Raspberry PI, 7 – system of LEM transducers, 8 – load, 9 – personal computer.

The signals supplied to the inputs of the MicroDAQ E2000 device were processed using an application purpose-built to monitor the wind turbine under test (Fig. 4). The Scilab 5.5.2 was used to develop the program. The main application code is shown in Fig. 5.

The program used standard functions available in Scilab program libraries (ADC, DIO, MUX, DEMUX, Func key, STOP, LED, To file), as well as user's functions (WindSpeed, RotSpeedFreq, Power3P). The user's function codes were written in C language. Currents and voltages signals were used to calculate the active power generated by the synchronous generator. The power P was calculated as an average value of the instantaneous power calculated as the sum of the product of currents and voltages:

$$P = \frac{1}{n} \sum_{n=1}^n (i1_n u1_n + i2_n u2_n + i3_n u3_n) \quad (1)$$

Where:

n - number of samples in the analyzed buffer,
 $i1_n, i2_n, i3_n$ - currents in phase 1, 2 and 3 for n -th sample,
 $u1_n, u2_n, u3_n$ - voltages in phase 1, 2 and 3 for n -th sample.

The size of the analysed buffer was calculated for the voltage frequency (basic component) and sampling frequency. The value of the voltage's frequency was calculated based on the measured value of the generator's rotational speed and the number of generator's magnetic poles.

Mechanical torque was measured by torque meter. Torque meter's output signal was a voltage signal. To receive the value of torque in Nm it was necessary to multiply the voltage by a coefficient dependent on the chosen range. Used torque meter had three measurement ranges. For first range value of the coefficient was equal to 1.67 [Nm/mV], for the second range value of the coefficient was equal to 3.33 [Nm/mV] and for third range value of the coefficient was equal to 6.67 [Nm/mV].

The rotational speed of the generator was measured by an inductive sensor mounted under the mechanical clutch, connecting torque meter with the generator. The mechanical clutch had four teeth on the circumference. Each tooth generated one voltage pulse at the output of the sensor.

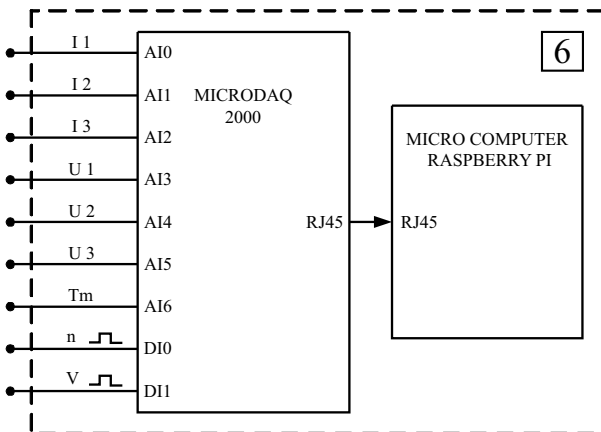

Fig. 4. Signal connection to Micro DAQ E2000 and microcomputer Raspberry PI.

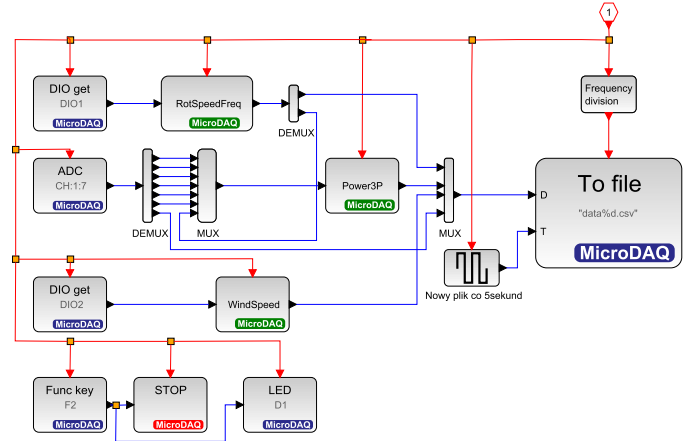

Fig. 5. The main program loop for monitoring the operating parameters of a VAWT developed in the Scilab environment.

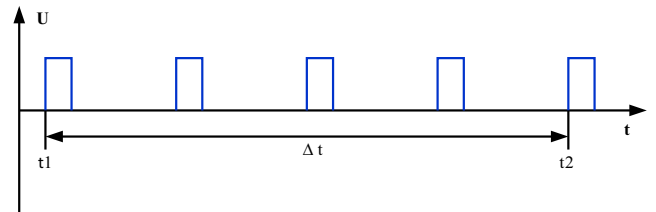

Fig. 6. Waveform of the voltage signal generated by the inductive sensor for one rotor turn.

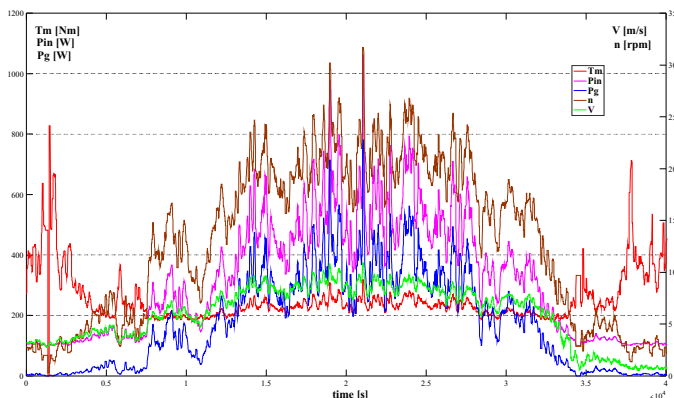

Fig. 7. The time series of the generator with load's resistance of 7.3 Ω /phase: Tm - torque on generator's shaft, Pin - power on generator's shaft, Pg - generator's output power (generated power), V - wind speed, n - generator's rotational speed.

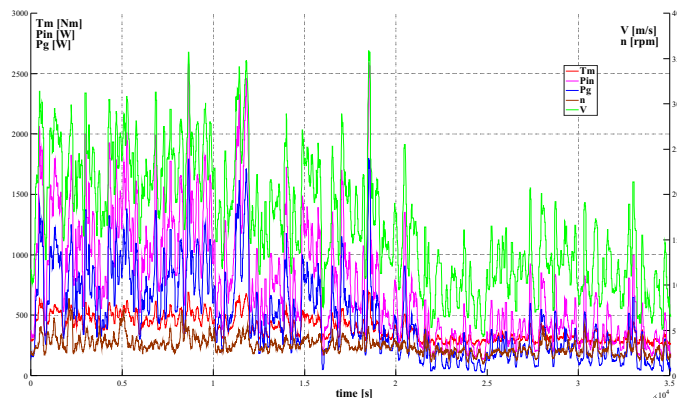

Fig. 8. The time series of the generator with load's resistance of 3.65 Ω /phase: Tm - torque on generator's shaft, Pin - power on generator's shaft, Pg - generator's output power (generated power), V - wind speed, n - generator's rotational speed.

Elaborated software implemented in Micro DAQ card had measured the time between the first and fifth voltage pulse at the output of the inductive sensor (Fig. 6). Based on this time, the rotation speed was calculated.

$$n = \frac{1}{\Delta t} rpm \quad (2)$$

Where:

Δt - the time between 1st and 5th voltage pulse at the output of the inductive sensor in minutes.

The speed of the wind was measured by the wind's speed meter. It generated rectangular voltage signal, one pulse per one turn. The average frequency of generated waveform equal to 1 Hz meant wind speed equal to 1 m/s.

The pulse signals were connected to the digital inputs of the measurement card, which reduced the influence of the noise in the measured signal. Moreover, it was easier to recognize the rising edges of the pulse signal due to the possibility of using functions dedicated to that kind of inputs.

All signals were measured with sampling frequency equal to 1 kHz. Next, the average values for 1 second's time were calculated and saved in the internal memory of Micro DAQ E2000 device.

IV. MEASUREMENT RESULTS

The research program provided for registration of the measurement's results within a period of 14 days. Fig. 7 and Fig. 8 show selected results registered during the operation of the VAWT. The measurements have been made for two values of the load resistance - 7.25 Ω /phase and 3.65 Ω /phase. Moreover, all of the results have been prepared as statistical analyses in a graphical form. Fig. 9 refers to the case when the generator was loaded with a three-phase resistor with a resistance of R = 7.25 Ω . Fig. 10 refers to the case when the generator was loaded with a three-phase resistor with a resistance of R = 3.65 Ω .

V. CONCLUSIONS

The proposed solution for remote monitoring of operating parameters of a VAWT can be used in low power measurement systems. Low cost of measuring equipment and its large capabilities allow for online monitoring the values of currents, voltages, active power, generator's speed, wind's speed and torque on the turbine shaft.

In case of the system powered from a battery pack, it is advisable to monitor the value of the supply voltage (battery pack voltage) promptly to avoid measurement errors. Those may be a result of changing parameters of transducers used in the system, e.g. change of the constant for LEM type transducer.

The developed system of remote monitoring of VAWT's operation parameters can be used to determine load characteristics of a wind turbine. Such an application, however, requires the use of an additional module enabling the generator's load to be controlled in order to obtain a maximum power value for a given wind's speed value (using the MPPT algorithm).

REFERENCES

- [1] C. Stout, S. Islam, A. White, S. Arnott, E. Kollovozi, M. Shaw, G. Droubi, Y. Sinha, and B. Bird, "Efficiency improvement of vertical axis wind turbines with an upstream deflector," *Energy Procedia*, vol. 118, pp. 141 - 148, 2017, 2017 2nd International Conference on Advances on Clean Energy Research (ICACER 2017), Berlin, Germany April 7-9, 2017.
- [2] K. Rogowski, R. Maroński, and J. Piechna, "Numerical analysis of a small-size vertical-axis wind turbine performance and averaged flow parameters around the rotor," *Archive of Mechanical Engineering*, vol. 64, no. No 2, pp. 205-218, 2017.
- [3] R. J. Preen and L. Bull, "Toward the coevolution of novel vertical-axis wind turbines," *IEEE Transactions on Evolutionary Computation*, vol. 19, no. 2, pp. 284-294, April 2015.
- [4] K. M. Almohammadi, D. B. Ingham, L. Ma, and M. Pourkashanian, "2-d-cfd analysis of the effect of trailing edge shape on the performance of a straight-blade vertical axis wind turbine," *IEEE Transactions on Sustainable Energy*, vol. 6, no. 1, pp. 228-235, Jan 2015.
- [5] J. L. Menet and S. Dupont, "Aerodynamic characterization of a vertical axis wind turbine using a mechatronical experimental setup," in *2016 11th France-Japan 9th Europe-Asia Congress on Mechatronics (MECATRONICS) /17th International Conference on Research and Education in Mechatronics (REM)*, June 2016, pp. 225-229.

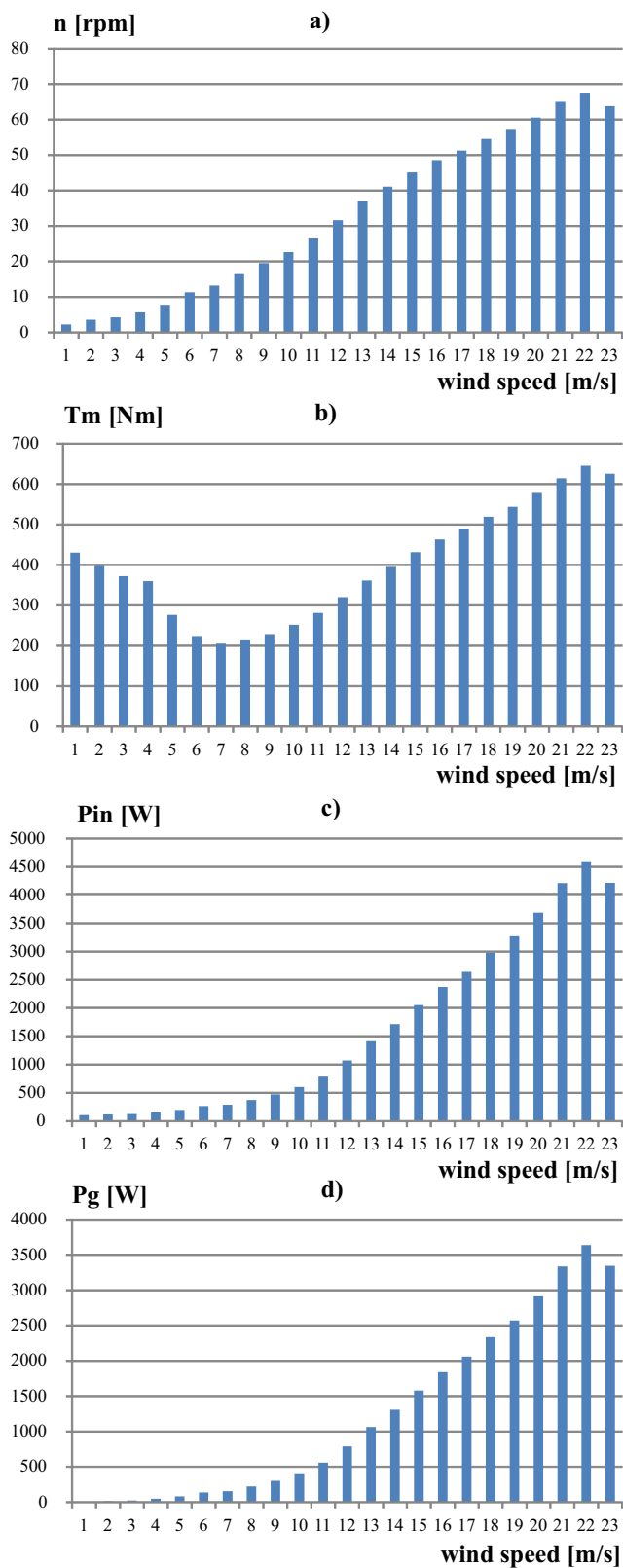

Fig. 9. Results of statistical analysis of measurements for a loaded generator: (a) generator's rotor speed, (b) torque on generator's shaft, (c) mechanical power on generator's shaft, (d) generator's output active power for $R=7.25\Omega$ and power of 5 kW.

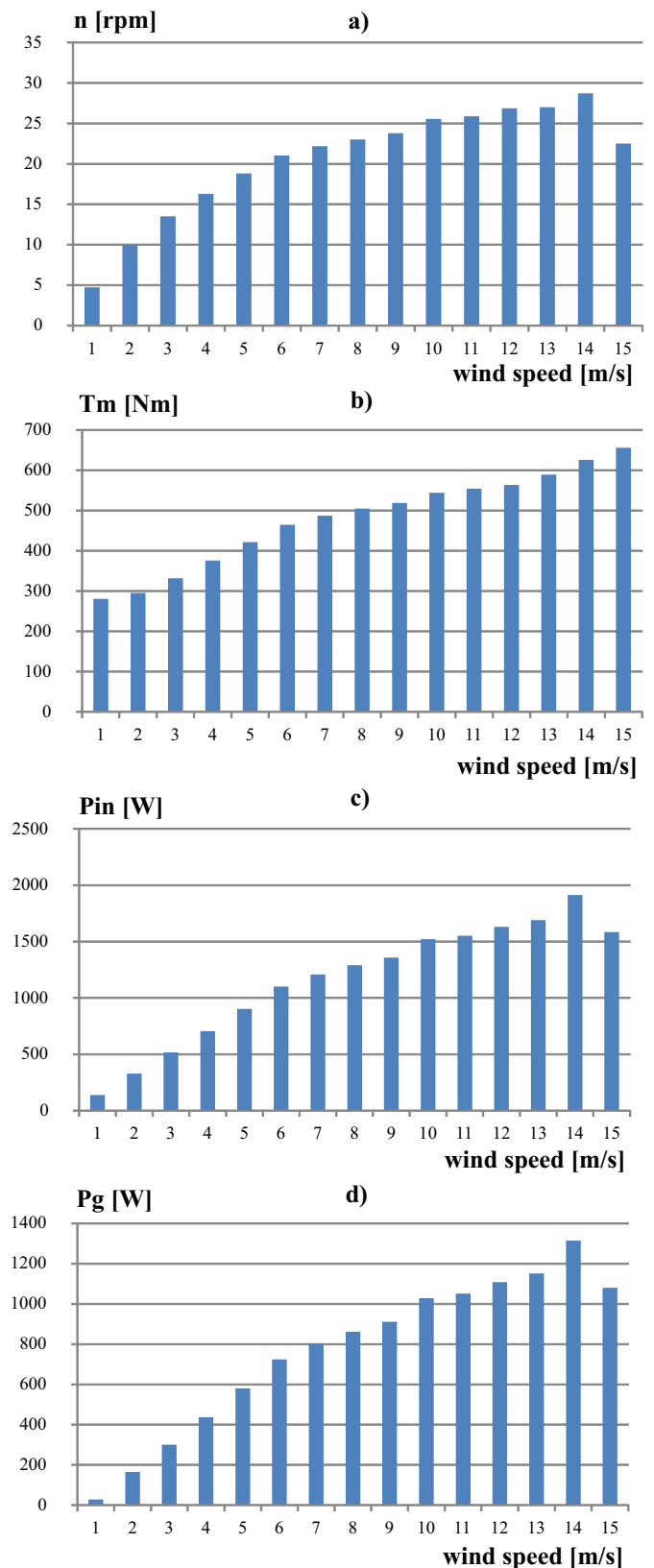

Fig. 10. Results of statistical analysis of measurements for a loaded generator: (a) generator's rotor speed, (b) torque on generator's shaft, (c) mechanical power on generator's shaft, (d) generator's output active power for $R=3.6\Omega$ and power of 10 kW.



- [6] N. Stannard and J. R. Bumby, "Performance aspects of mains connected small-scale wind turbines," *IET Generation, Transmission Distribution*, vol. 1, no. 2, pp. 348–356, March 2007.
- [7] M. Parker and C. Soraghan, "Comparison of power electronics lifetime between vertical- and horizontal-axis wind turbines," *IET Renewable Power Generation*, vol. 10, pp. 679–686, 05 2016.
- [8] A. Ahmed, L. Ran, and J. R. Bumby, "New constant electrical power soft-stalling control for small-scale vawts," *IEEE Transactions on Energy Conversion*, vol. 25, no. 4, pp. 1152–1161, Dec 2010.
- [9] M. Morawiec, A. Lewicki, and Z. Krzeminski, "Power electronic transformer for smart grid application," 03 2015, pp. 1–6.
- [10] F. Wilczyński, M. Morawiec, P. Strankowski, J. Guziński, and A. Lewicki, "Sensorless field oriented control of five phase induction motor with third harmonic injection," in *2017 11th IEEE International Conference on Compatibility, Power Electronics and Power Engineering (CPE-POWERENG)*, April 2017, pp. 392–397.
- [11] G. Kostro, F. Kutt, M. Michna, and M. Ronkowski, "Low speed permanent magnet synchronous generator for vertical axis wind turbine," in *2017 International Symposium on Electrical Machines (SME)*, June 2017, pp. 1–5.
- [12] A. Cichowski, S. Bujacz, J. Nieznanski, and P. Szczepankowski, "Sensorless startup of super high speed permanent magnet motor," in *2010 IEEE International Symposium on Industrial Electronics*, July 2010, pp. 3101–3106.

