



## **Jacek Soltys**

Department of Urban and Regional Planning  
Gdansk University of Technology  
jacek.soltys@gmail.com

# **Typology of towns in the peripheries of Polish coastal regions: conclusions for urban policy**

## **Abstract**

Peripheries means the land outside metropolitan areas. One of the main problems in these areas is a lack of growth factors. Some towns can contribute to the development of these regions, because there are few such factors, and it is easier to create the new ones, especially in urban policy.

The subject of this paper is a typology of towns within the Polish peripheral coastal regions, limited to towns with more than 5 thousand inhabitants. Its purpose is to recognize diverse role of towns in the regional development, and to create the basis for the formulation of urban and regional policy. Typology takes into account the state of economic development, the external functions of towns, their impact, as well as present and future transport accessibility. Two kinds of systematization were applied: 1) quantitative typology applying Principal Components Analysis (PCA) and the cluster analysis using the k-means algorithm, 2) qualitative classifications. Then synthetic typology was done. As a result of the typology, there were identified important towns for the future development of peripheral areas and formulated the conclusions for regional planning and urban policy.

**Keywords:** towns, typology, development factors, peripheral areas, urban policy, regional policy, regional planning.

**JEL Classification:** C38, O21, O52, R58.

## **Introduction**

The areas outside metropolitan areas are called peripheries. A common phenomenon is the big difference in levels of development, especially between metropolitan areas and areas beyond. There is also the following paradoxical phenomenon:

- Natural increase in population is negative in big cities, which are the poles of development and growth for the demand for labor.
- Natural increase in population is positive in peripheries, especially in the countryside, where there is a lack of jobs and economic development factors.

The logical consequence of the above should be migration from peripheral areas, especially from rural to metropolitan areas. However, there are at least two barriers being faced in Poland: housing and mentality – the reluctance to emigrate. There are some advantages: excessive emigration would result in ‘leaching’ development factors: migration of active, better educated people, which reduces the opportunities for development of peripheral areas. Therefore, there is a need for regional development policy in these areas.

A lack of development factors in peripheries become barriers for development. To overcome these barriers interventions are needed as a part of the regional policy. An urban policy is also needed, because some towns can contribute to the development of peripheries. The following is a basis for argument:

- In towns there are few development factors, and it is easier to create new ones.
- Towns develop their own central functions.
- In towns it is easier to localize the majority of new investments because:
  - it is easier to extend existing infrastructure than create new,
  - towns have existing and easily available workforces,
  - it is easier to get new staff from outside to the city.
- There is usually better accessibility to towns than to villages (Soltys 2011).

The subject of this paper is a typology of towns within the peripheries of Polish coastal regions. This typology was prepared as part of the research conducted in the Department of Urban and Regional Planning, Faculty of Architecture, Technical University of Gdansk. The theme of the research is “Cities in the activation of peripheral areas, based on the example of the northern Polish regions”.

The purposes of the typology were:

- Recognition of the diverse role of towns in the regional development,
- Creation of the basis for the planning of urban and regional policy.
- Examination of the usefulness of the typology based on data from public statistics (Local Data Bank of Central Statistical Office) for regional and urban policy planning.

For implementation purposes mentioned above, two kinds of systematization were applied:

- Quantitative typology applying Principal Components Analysis (PCA) and the cluster analysis using the k-means algorithm.
- Qualitative classifications.



For quantitative typology, only data from the Central Statistical Office and the statistical offices in voivodships were used. For one third of towns with less than 5 thousand inhabitants, the number of employed persons in some sectors of the economy are not published due to statistical confidentiality. For this reason, the research was limited to towns with more than 5 thousand inhabitants.

Typologies of many sets of Polish towns were prepared, but most of them for other regions and before the year 2000. For the northern Polish regions (among them the coastal regions) the typology was prepared by the author of this paper (Sołtys 2010); but only for the little towns and without PCA. PCA and cluster analysis are used, among others, for typology of towns and regions (Crescendi, Rodrigues-Pose 2011; Shepherd 2009). In this method a large number of related variables are transformed to a smaller set of uncorrelated variables (Jackson 1991). Cluster analysis is the preferred generic term for procedures which seek to uncover groups of data (Everitt et al. 2011).

## **1. General characteristics of the peripheries of Polish coastal regions**

There are two Polish coastal voivodeships: Pomeranian and West Pomeranian. There are two metropolitan areas in these voivodeships: Gdansk (also called Tricity) and Szczecin. Delimitation of the peripheral area was based on the author's earlier work, which includes in total: 4 subregions denoted by NUTS3, 2 counties (poviats) in the subregion Szczecinski and 1 county in the subregion Gdanski.

Seaside location has an impact on the high tourist attraction, but there are economic problems arising from the protection of the Baltic Sea fish stocks and fishing limits. The biggest area is the Lake District of Pomerania, which is characterized by diverse land reliefs, lakes, and forests, making the location also very attractive for tourism. Weakness of tourism in the study area is the short season, which lasts only 2 months at the seaside and 4-5 months in the Lake District. A few facilities and especially the health resorts have a year-long function. Sightseeing tourism, especially in some towns, can extend also throughout the whole year, but except for a few towns (Malbork, Frombork) the coverage and scale of tourism seems rather small.

Lands left by the German population and settled by the Polish population after WW II are a considerable part of the Polish coastal regions. Many state rural farms were located in these lands. The transformation to market economy has caused their decay, leading to high unemployment in the countryside and the related problems of social dysfunction (inaction, alcoholism), as well as personal



and inherited poverty. Loss of work by entire families has started decreasing the demand for the local service sector in towns.

There are 92 towns in the periphery of Polish coastal voivodships (Table 1). For 50 of them typology was prepared.

**Table 1.** Characteristics of the set of towns in Polish coastal voivodships (2011)

Voivodship	Area	Number of towns				
		Population in thousands			Researched	Total
		>20	5-20	<5		
Pomeranian	Metropolitan	8	3	3	–	14
	Peripheral	7	15	6	22	28
West Pomeranian	Metropolitan	5	0	0	–	5
	Peripheral	6	22	36	28	64
Total peripheral		13	37	42	50	92
Total		26	40	45	–	111

Source: Central Statistical Office (2011) and own calculations.

## 2. Quantitative typology

Processes of quantitative typology based on PCA and cluster analysis were described among others by Shepherd (2009) in terms of four main stages as follows:

1. The selection and preparation of variables (including standardization).
2. Finding patterns of variation in the data (using PCA).
3. Scoring towns on the dimensions of Variation (by a matrix of transformed data).
4. Grouping towns (using k-means method).

The 18 input variables characterizing each town were selected so as to cover the 4 following aspects of a town important for development of the town and its surroundings:

1. Stage of economic development.
2. The impact of economy on the town and its surroundings.
3. Town function.
4. Town size.

The abbreviations of variables used in the tables are in parentheses.

Stage of economic development was measured by the following indicators (all variables except 6 and 8 per 1,000 habitants in working age):

1. Commercial companies per 1,000 habitants in working age (CC).
2. Commercial companies with foreign capital participation (CCFC).
3. Natural persons conducting economic activity per 1,000 in working age (NPEA).
4. Number of entities of the national economy employing 10-49 persons (EN\_SM).



5. Number of entities of the national economy employing 250 and more persons (EN\_L).
6. Dynamics of number of employed persons (DEN).
7. Employed persons (EMP) in urban-rural gminas (communes) and urban gminas together with rural gminas surrounding them.
8. Dynamics of number of entities of the national economy employing 10-249 persons (DEMP).

The impact of economy on the town and its region was measured by the indicators:

9. Journeys to work – balance of arrivals and departures for work per 1,000 habitants in working age (JW).
10. Percentage of registered unemployed persons of working age (UNEM).

Functions of towns cannot be measured by Floren's indicator (Runge 2006) because numbers of employed persons (total and in most economic sectors) in towns are unknown (public statistics do not include economic entities employing up to 9 persons). As a consequence, is impossible to count a percentage of employed person in sectors of the economy. For this reason, functions of towns were measured by numbers of employed persons per 1000 habitants in working age:

11. In industry and construction (EMI).
  12. In marked services – except financial, insurance and real estate activities (EMMS).
  13. In mainly non-marked (public) services (EMPS).
- For the mainly non-market (public) services there were also the following measures:
14. Pupils in upper secondary schools (PUSS) – total.
  15. Pupils in upper secondary schools per 100 population in ages 16-18 (PUSSP).
  16. Services (SERV).

The last measure is expressed in points, which expresses the number of services (specific to the county level and higher levels of service) from the following list: County Office, County Labour Office, Tax Office, local branch of the Department for Work and Pensions (ZUS), court.

The level of tourist function development was measured by the indicator:

17. Overnight stays (nights spent) in tourist collective accommodation establishments per 1000 capita (TOUR).

The measurement of town size was taken into account as affecting the attractiveness for the external investments (the larger city: the more qualified staff, better business support services, more investment areas). It is:

18. Town population (POP).



A standardized measure comparable between variables was input into the analysis.

The correlations between these 18 variables were calculated (Pearson's product-moment correlations). The highest correlation coefficients are:

- Population and:
  - pupils in upper secondary schools (0.95),
  - services (0.85).
- Employed persons and employed persons in industry and construction (0.77).
- Natural persons conducting economic activity and:
  - commercial companies (0.70),
  - nights spent in tourist collective accommodation per 1,000 capita (0.76).

Furthermore Principal Components Analysis brings out underlying dimensions from the inter-relationships between the variables so that the components are unrelated to one another, that is, they represent statistically independent structures within the original data (Shepherd 2009). "The main idea of PCA is to reduce the dimensionality of a data set consisting of a large number of inter-related variables, while retaining as much as possible of the variation present in the data set" (Lolliffe 2002, p. 1).

Table 2 presents a matrix of factor loadings of 6 principal components. The bottom row contains the eigenvalues. Only for 6 components the eigenvalues are greater than 1, so only the 6 components were included in the typology.

**Table 2.** Principal components

Np.	Variables	PC1	PC2	PC3	PC4	PC5	PC6
1	CC	-0.314	-0.296	0.050	0.068	-0.049	0.014
2	CCFC	-0.184	-0.345	0.183	0.095	0.218	0.069
3	NPEA	-0.186	-0.394	0.156	-0.161	0.133	-0.148
4	EN SM	-0.150	0.049	0.390	-0.335	-0.393	0.188
5	EN L	-0.114	0.243	0.092	0.316	0.538	-0.197
6	DEN	0.002	0.323	0.074	-0.247	0.236	-0.261
7	EMP	-0.292	0.247	0.270	0.151	-0.165	-0.121
8	DEMP	0.099	0.014	0.187	-0.290	-0.216	<b>-0.721</b>
9	JW	-0.265	0.182	0.346	0.131	0.272	0.133
10	ENEM	0.231	0.095	0.054	-0.211	0.267	-0.156
11	EMI	-0.109	0.234	0.328	0.463	-0.335	-0.116
12	EMMS	-0.337	-0.141	-0.020	-0.131	-0.033	-0.147
13	EMPS	-0.245	0.204	0.029	-0.381	0.240	0.079
14	PUSS	-0.102	-0.437	0.210	-0.002	0.163	-0.128
15	PUSSP	-0.312	0.016	-0.390	0.119	-0.090	-0.236
16	SERV	-0.251	0.219	0.024	-0.345	0.002	0.347
17	TOUR	-0.336	0.077	-0.353	0.037	-0.092	-0.127
18	POP	-0.329	0.088	-0.336	-0.082	-0.014	-0.055
Eigenvalues		5.788	3.368	1.993	1.516	1.235	1.149

The typology was based on the transformed data matrix for 6 principal components from PCA. The final stage is to cluster towns according to their scores on the 6 main dimensions in this transformed data. The data analyst J. Łosiński made the typology using the k-means algorithm. It is based upon the numerical 'distances' between the objects (towns) when represented by the scores on the 6 component dimensions. The algorithm finds a division within the data in which the towns within each cluster are as close to each other and as far from towns in other clusters as possible (Shepherd 2009). The result is shown in Table 3 and 4.

A total of 5 typologies have been done – from 4 to 7 clusters and an additional one of 10 clusters. Each type was characterized by: minimum, maximum, average, and standard deviations. "The critical decision on the number of groups making up the typology is a subjective one" [...] as a compromise between more detail [...] and more generality" (Shepherd 2009, p. 8). It was concluded that the typology comprised of 7 clusters best describes the set of the towns, and is best suited for interpretation. Table 3 contains the characteristics of the types by average values of principal components.

**Table 3.** Quantitative characteristic of types by principal components

Type	Number of towns	Measure	PC1	PC2	PC3	PC4	PC5	PC6
1	6	SD	2.02	0.90	1.38	0.72	0.38	0.93
		Average	<b>-3.61</b>	<b>0.56</b>	<b>-1.54</b>	<b>0.93</b>	<b>-0.44</b>	<b>-0.61</b>
		Max.	-1.69	1.91	0.97	2.51	-0.03	0.48
		Min.	-6.77	-0.45	-2.93	0.40	-1.15	-2.26
2	2	SD	0.97	1.32	0.65	0.65	1.31	0.80
		Average	<b>1.37</b>	<b>-0.94</b>	<b>-0.05</b>	<b>1.29</b>	<b>0.63</b>	<b>0.58</b>
		Max.	2.86	0.18	1.23	2.62	3.11	1.21
		Min.	-0.08	-3.41	-0.91	0.58	-1.65	-1.28
3	8	SD	0.93	1.02	0.96	1.58	0.57	0.68
		Average	<b>-1.39</b>	<b>1.07</b>	<b>1.23</b>	<b>-0.98</b>	<b>-0.11</b>	<b>0.45</b>
		Max.	-0.28	2.92	2.43	2.41	0.75	1.14
		Min.	-2.87	-0.60	-0.75	-3.22	-1.14	-0.50
4	6	SD	0.98	0.45	0.54	0.59	0.55	0.73
		Average	<b>0.02</b>	<b>0.29</b>	<b>-0.50</b>	<b>-0.43</b>	<b>0.18</b>	<b>0.54</b>
		Max.	1.64	1.11	0.46	0.34	1.40	2.14
		Min.	-1.53	-0.28	-1.28	-1.64	-0.89	-0.61
5	15	SD	0.85	1.42	0.93	1.31	2.13	0.80
		Average	<b>1.66</b>	<b>1.35</b>	<b>1.60</b>	<b>0.09</b>	<b>-0.79</b>	<b>-1.44</b>
		Max.	2.67	4.03	3.11	2.83	3.05	-0.39
		Min.	0.31	-0.01	0.52	-1.27	-2.99	-2.84
6	8	SD	1.15	2.69	1.50	0.24	0.53	0.36
		Average	<b>-3.52</b>	<b>-6.02</b>	<b>1.82</b>	<b>-0.47</b>	<b>0.79</b>	<b>-1.15</b>
		Max.	-2.37	-3.33	3.32	-0.24	1.32	-0.78
		Min.	-4.68	-8.71	0.32	-0.71	0.27	-1.51
7	5	SD	0.84	0.45	0.65	0.67	0.42	0.85
		Average	<b>3.73</b>	<b>-0.95</b>	<b>-1.20</b>	<b>-0.23</b>	<b>-0.20</b>	<b>-0.35</b>
		Max.	5.08	-0.50	0.06	0.44	0.22	0.62
		Min.	2.53	-1.53	-1.84	-1.45	-0.84	-1.49

Note: SD – standard deviation. The smaller the standard deviation, the darker the field.



The characteristic of the types by average input variable values of standardized data is more readable. In order to reduce the number of variables, some variables were combined in the synthetic ones: economic development (ED) and service function (SF). The simplified characteristic of types is described in Table 5.

**Table 4.** Quantitative characteristic of types

Type	ED	SF	NPEA	UNEM	JW	TOUR	POP
1	0.72	1.58	0.09	-0.81	0.44	-0.27	2.13
2	1.08	0.51	3.37	-1.20	0.28	4.47	0.26
3	0.75	0.80	0.10	-0.14	0.97	-0.22	-0.28
4	0.91	-0.88	-0.60	0.57	-0.14	-0.27	-0.63
5	-0.36	0.30	-0.11	0.17	-0.09	-0.26	-0.05
6	-0.66	-0.94	-0.09	-0.20	0.02	0.17	-0.44
7	-1.45	-1.36	-0.41	0.79	-1.80	-0.29	-0.58

**Table 5.** The simplified characteristic of types

Type	Characteristic of types	Towns
1	High level of economic development, the highest level of service function development and the highest level of population	Chojnice, Koszalin, Kwidzyn, Słupsk, Stargard Szczeciński, Starogard Gdański
2	The highest level of economic development, health-resort, the highest level of tourist development	Kołobrzeg, Międzyzdroje
3	High level of economic and service function development, the highest indicators journeys to work	Barlinek, Bytów, Chojna, Człuchów, Gryfice, Kamień Pomorski, Kościerzyna, Sławno
4	High level of economic and service function development, low level of service function development	Brusy, Czaplonek, Czarne, Czersk, Dzierżgoń, Skarszewy
5	Level of economic development a bit below average, level of service function development a bit above average	Białogard, Choszczno, Drawsko Pomorskie, Lębork, Malbork, Miastko, Myślibórz, Nowogard, Nowy Dwór Gdański, Pelplin, Pyrzyce, Szczecinek, Sztum, Świdwin, Wałcz
6	Low level of economic and service function development, low level of service function development	Darłowo, Dębno, Gniew, Karlino, Łobez, Połczyn-Zdrój, Trzebiatów, Ustka
7	The lowest level of majority of features	Debrzno, Prabuty, Sianów, Wolin, Złocieniec

### 3. Qualitative classifications

Statistical characteristics of towns are not enough for the planning of regional and urban policy. Necessary spatial analyses may include:

- Transport accessibility of towns – current and future, as one of the development factors, especially a value for the location of the external investments;
- Town impact areas for development;
- Impact areas of towns as existing or potential sub regional centres.

When analysing transport accessibility of towns, coverage of the possible activating impact of roads must be taken into account. There is a tendency to





locate small and medium plants near local roads with a distance of up to 5 km from the nearest motorway junction. For larger plants this distance is 15 km (Kołodziejcki et al. 2000). For the expressways, the shorter distance is assumed (10 km). These distances were used for classifying towns according to the criterion of transport accessibility as shown in Table 6.

**Table 6.** Classification according to criteria: transport accessibility and town's size as the attractiveness for the plants location

Road		Medium towns (possibility for location of larger plants)	Small towns (possibility for location of small and medium plants)
Motorway (existing)		Starogard Gdański	Pelplin
Expressway	existing		Myślibórz, Pyrzyce
	under construction		Nowy Dwór Gdański
	in plans	Koszalin, Słupsk, Lębork, Białogard	Nowogard, Sławno, Karlino

Source: *Koncepcja...* (2011).

When analysing town impact areas for development, the scenario model of activating such areas shown in Figure 1. can be taken into account. The town impact area is difficult to clearly define, because the intensity of commuting to work decreases with increasing distance. According to the researches done for the Poviats (County) Offices of Labor (*Raport...* 2008) the accepted trip distance to work is a maximum of 30 km. A daily urban-system, as an area of daily trips to work, can be a module of regional policy. This corresponds to the size of many counties. This indicates the suitability of county capitals to serve as activating centres as a base of development of the periphery. But according to spatial analyses, there is no need to make Łobez and Sztum activating centres. Myślibórz and Pyrzyce (and Barlinek – which is more economically developed, but not a county capital) are alternative centres. Impact areas of county capitals don't cover all the peripheral areas. Some others towns suitably located and well connected with their surroundings should also be in the class of towns suitable as activating centres. Such towns are some towns from type 3 and 4: Chojna, Czaplinek and Czernik.

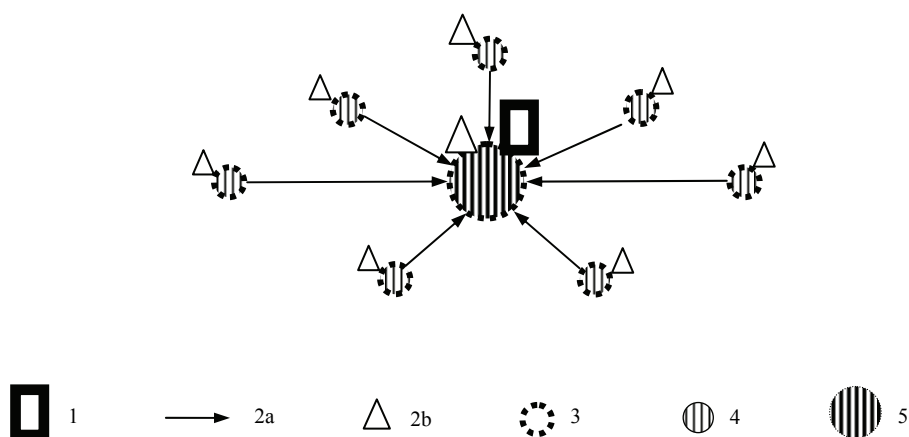
**Figure 1.** Scenario model of activating the fragment of the peripheral area

Note: Sequence of events: 1 – location of new activities or development of existing exogenous activities and growth of employment, 2 – increase of work trips and in parallel: 2b – increase in revenues of new employees stimulating endogenous demand, 3 – development of endogenous, local and central activities for the town and its surroundings boosting employment and revenues of populations, 4 – village, 5 – town.

Source: Soltys (2011).

Superimposing quantitative typology and qualitative classifications yields too many classes or types of towns with numerous possible groupings. Synthetic typology that takes into account the application in planning regional and urban policy is presented in the next chapter.

#### 4. Synthetic typology and its application in the regional and urban policy

The following are key questions in planning regional and urban policy:

1. Which towns should be supported to develop peripheral areas?
2. What aspects of town economy should be supported, that is, what supporting directions can be applied?

The daily urban systems could be a module in regional planning for a regional and urban policy of development of the periphery. County capitals and some towns from types 3 and 4 should be recognized as activating centres. The directions of the urban policy for supporting these towns can be as follows:

1. Improving the competitiveness of the local exogenous sector (especially small and medium enterprises; a positive outcome can mean small enterprises grow into medium sized ones).

2. Improving attractiveness for external investments including supporting the creation and promotion of new investment areas.

In some towns, especially in subregional and county centres, in parallel with the actions mentioned above, public services will be developed and conditions for location of commercial services will be improved. Regional planning should manage monitoring, identify the low development areas, define Strategic Support Areas and indicate among them:

- Sub regional Service centres in which development of sub regional services will be supported by the ways mentioned above,
- Activation centres:
  - for improvement in the competitiveness of the local exogenous sector,
  - for improvement in attractiveness for external investments.

Taking into account matter mentioned above the **synthetic typology** could be as following:

1. Sub regional Service Centres: Chojnice, Koszalin, Słupsk, Kołobrzeg, Starogard Szczeciński, Szczecinek.
2. Towns suitable as activation centres that are economically well-developed:
  - a) to support development of the local exogenous sector and county services: Kwidzyn, Bytów, Człuchów, Kamień Pomorski, Kościerzyna;
  - b) to support development mainly of the local exogenous sector: Chojna, Czaplinek, Czersk, Barlinek;
  - c) to support in various directions (as mentioned above and improve attractiveness for external investments): Starogard Gdański, Gryfice, Sławno.
3. Towns suitable as activation centres to improve attractiveness for external investments and support development of county services, economically developed below average: Pyrzyce, Myślibórz, Nowy Dwór Gdański, Białołog, Nowogard, Wałcz, Lębork.
4. Towns suitable as activation centres to support development of services and other activities according to individual studies, economically developed below average: Malbork, Świdwin, Dębno, Choszczno, Miastko
5. Others towns – more economically developed: Międzyzdroje, Brusy, Czarne, Dzierżoń, Skarszewy
6. Others towns – less economically developed: Drawsko pomorskie, Pelplin, Sztum, Darłowo, Gniew, Karlino, Łobez, Połczyn-Zdrój, Trzebiatów, Ustka, Debrzno, Prabuty, Sianów, Wolin, Złocieniec.

Typology can only be the first step for indicating activating centres. It is also necessary to take into account the individual characteristics of the towns with respect to competitiveness of products, stability of economy, clusters and other economic details, human and social capital, efficiency of institutions, etc.

These features should be known from strategic planning using SWOT or marketing analysis. There are also important political considerations for urban policy including the readiness of the partnership.

There is a problem concerning the support because it is impossible to predict what kinds of support (permitted in the European Union) bring some effect, what effect and where. In some places businesses achieve great success without support, which seems accidental. Also, external enterprises (especially transnational corporations) that initially invest will then relocate production to another country where conditions are better.

## Conclusions

Regional planning should define the two kinds of centres mentioned above, according to two criteria: the role (level) as service centre and the role in development, that is: subregional centres and activation centres.

In activation centres two kinds of urban policy are possible – either to improve the competitiveness of the local exogenous sector or the attractiveness for external investments.

Statistical characteristics of towns are not enough for the planning of regional and urban policy. Typology or classification based on spatial analyses is necessary concerning: transport accessibility, location of towns in the region, distances between them, their range (impact areas) as activation centres (as centres of daily urban systems) and as sub regional centres. It is also necessary to take into account the individual characteristics of the towns and political considerations for urban policy, including the readiness of the partnership. These are questions worth investigating in further research.

The current typology differs from the typology that was prepared in 2008 for another set of towns.

Also, due to difficulties in identifying the level of towns as a service centre (for ex. sub regional centres), it would seem better for this purpose to use classification than typology, based on special sets of data and spatial analysis.

The direction of further researches should focus on:

- Searching for an appropriate set of variables in the situation when data from public statistics are lacking.
- Testing methods by doing typologies and classification in a larger set of towns, and also in other voivodeships.



## References

- Central Statistical Office (2011), Local Data Bank, [www.stat.gov.pl](http://www.stat.gov.pl) (access: 5.05.2013).
- Crescendi R., Rodríguez-Pose A. (2011), *Innovation and regional growth in the European Union*, Heidelberg, Dordrecht, London, New York: Springer.
- Everitt B.S., Landau S., Leese M, Stahl D. (2011), *Cluster analysis*, Chichester: Wiley.
- Jackson J.E. (1991), *A user's guide to principal component*, New York: John Wiley & Sons.
- Kołodziejcki J., Parteka T., Dutkowski M., Szwanowski S. (2000), *Uwarunkowania kształtowania się strefy rozwojowej* [in:] W. Szydarowski (red.), *Strefa rozwojowa VI Korytarza TINA*, Gdynia: Urząd Miasta.
- Koncepcja przestrzennego zagospodarowania kraju 2030* (2011), Warszawa: Ministerstwo Rozwoju Regionalnego.
- Lolliffe I.T. (2002), *Principal component analysis*, New York: Springer.
- Raport szczegółowy dla powiatu kościerskiego na podstawie badań przeprowadzonych w 2007 r.* (2008), Sopot: Human Capital Business.
- Runge J. (2006), *Metody badań w geografii społeczno-ekonomicznej – elementy metodologii, wybrane narzędzia badawcze*, Katowice: Wydawnictwo Uniwersytetu Ekonomicznego.
- Shepherd J. (2009), *Typology of the smaller rural towns of England*, Rural Evidence Research Centre Birkbeck College, [www.rerc.ac.uk](http://www.rerc.ac.uk).
- Sołtys J. (2010), *Małe miasta w Polsce Północnej – typy i uwarunkowania rozwoju* [in:] K. Heffner, A. Polko (red.), *Transformacja funkcji miejskich w ośrodkach lokalnych*, Katowice: Wydawnictwo Akademii Ekonomicznej.
- Sołtys J. (2011), *Towns in the regional policy of activation of peripheral areas – choosing problems – the case of northern Poland* [in:] *New challenges for European regions and urban areas in a globalised world – 51<sup>st</sup> International European Congress of the Regional Science Association*, 30.08-3.09.2011 r., Barcelona, Spain.