

# Utility analysis and rating of energy storages in trolleybus power supply system

Mikołaj Bartłomiejczyk, Leszek Jarzebowicz

Department of Electrified Transportation  
Faculty of Electrical and Control Engineering, Gdańsk University of Technology  
Gdańsk, Poland

[mikolaj.bartlomiejczyk@pg.edu.pl](mailto:mikolaj.bartlomiejczyk@pg.edu.pl)

**Abstract**— The article discusses two energy storage applications in power supply system of public electrified transport. The first application aims at reducing the peak power of the traction substation. The second application increases effectiveness of using solar power plant to cover partial power demand of traction supply system. These two applications were discussed and analyzed based on trolleybus supply system in Gdynia, where most measurements were recorded.

**Keywords**—traction power supply; smart grids; traction substation; energy storage system; photovoltaic system; trolleybus

## I. INTRODUCTION

In European Union, transport is responsible for 30% of total energy consumption and 27% of total greenhouse emission [1]. Considering solely road transport, urban traffic is responsible for as much as 40% of total CO<sub>2</sub> emissions. These outcomes are related to the domination of combustion cars, especially cars fitted with diesel engines [2]. The emission of greenhouse gases needs to be reduced by at least 60% by 2050. Hence, a focus is set on ecological solutions to urban transport services. Whilst the use of electric trams and trolleybuses is common among large European cities, there is still much space for research on increasing their energy efficiency and decreasing their operational costs [3-7].

The use of storage energy systems (SES) in tram and trolleybus transport systems is becoming more common in the last years. The storages are often fitted into vehicles, which enables them to run on routes that are not whole-length equipped with catenary [8]. Installing energy storages both in vehicles and in traction substations allows for increasing the utilization of vehicles' braking energy [9-11]. Also, SES can be used to strengthen the power supply system locally [12].

The city of Gdynia (Poland) owns a trolleybus network, which is operated by Przedsiębiorstwo Komunikacji Trolejbusowej (PKT). In years 2009–2012, PKT realized complete modernization of the supply system, which decreased transmission losses and reliability [9-11, 13]. PKT also has carried out scientific and research activities aimed at reducing energy consumption. In 2014, in the framework of Civitas Dyn@mo project, a super-capacitor storage system Erecycler UCER-01 was installed in Wielkopolska substation [10]. In

2016, within Horizon 2020 Eliptic project, a bilateral supply system of catenary was implemented. Since 2019, PKT participates in EfficienCE project funded by the Interreg Central Europe. In EfficienCE, activities of PKT focus on implementation of energy storage system, which will be a part of future micro DC smart supply system. In parallel, further applications of storage energy systems are considered in order to reduce the peak power demand for traction substations and to cover a part of energy demand with a photovoltaic supply. These plans are the subject of this article.

## II. REDUCTION OF PEAK POWER DEMAND BY SES

The trolleybus' catenary is supplied from traction substations with the voltage of 600–750 V DC. Traction substations supply from one to several power supply areas, depending on their size. Previous publications on stationary SES were focused mainly on increasing of utilization of the braking energy or strengthening power supply systems [9-12]. However, it is also possible to use SES for other purposes, e.g. optimization of power consumption from the AC supply network, as described below.

The load of the traction substation varies in a broad range. In general, three periodical variations may be defined:

- weekly load cycle, related to different fleet operation on particular days of the week,
- daily load cycle, related to daily timetable (morning and afternoon peaks etc.),
- short-term load variations, resulting from instantaneous power demand of individual vehicles.

An exemplary waveform of power demand, recorded in traction substation Grabówek in 24-hour interval, is shown in Fig. 1.

Individual traction substations supply areas of a various size, which translates into various number of vehicles supplied from a single substation. Fig. 2 shows the daily average number of vehicles for five selected substations operating within Gdynia's trolleybus network. As it can be seen, the average number of vehicles may differ more than a dozen times between particular substations.

---

The article has been prepared within project TROLLEY 2.0 – Trolleybus Systems for Smart Cities. ERA-NET COFUND Electric Mobility Europe (EMEurope) cofunded by the European Commission as part of the ERA-NET Confund scheme under Horizon 2020 Programme for EU funding programme for research and innovation under grant agreement no. 723977.

The article has been prepared within project EfficienCE Energy Efficiency for Public Transport Infrastructure in Central Europe funded by the Interreg CENTRAL EUROPE under grant agreement CE1537.

© 2020 IEEE. Personal use of this material is permitted. Permission from IEEE must be obtained for all other uses, in any current or future media, including reprinting/republishing this material for advertising or promotional purposes, creating new collective works, for resale or redistribution to servers or lists, or reuse of any copyrighted component of this work in other works.

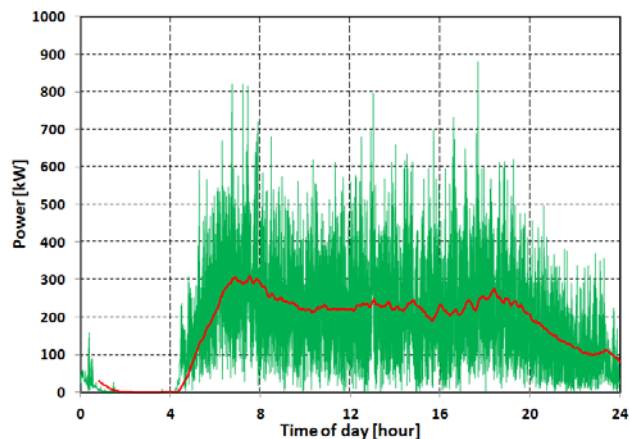

Fig. 1. An exemplary waveform of substation load during a day recorded for traction substation TS5 (Grabówek); red waveform is the moving average

Individual traction substations supply areas of a various size, which translates into various number of vehicles supplied from a single substation. Fig. 2 shows the daily average number of vehicles for five selected substations operating within Gdynia's trolleybus network. As it can be seen, the average number of vehicles may differ more than a dozen times between particular substations.

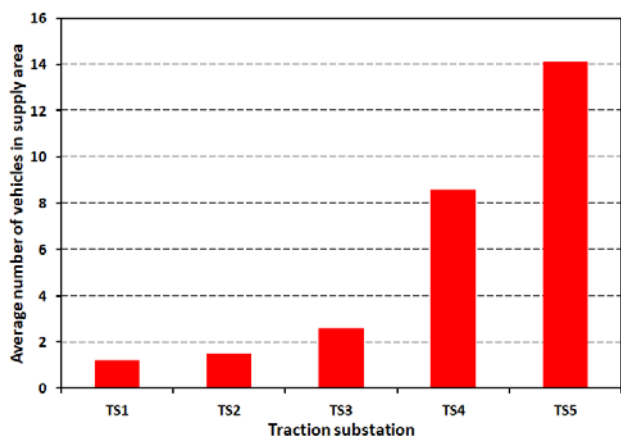

Fig. 2. The average number of vehicles in supply areas of several traction substations in Gdynia

Due to the variable load of traction supply system, this load can be described statistically by various duration-related indicators. Fig. 3 shows the maximal loads calculated as a mean power over the defined time ranges (from 1 s to 12 h). The figure includes five traction substations (TS1÷TS5), the indicators were computed based on experimental recordings.

From the practical point of view, the following parameters are of most importance:

- maximum of the 1-second average load power, as it corresponds to ratings of equipment,
- maximum of the 15-minute average load power, which is used for contracting with the electricity supplier (so-called 15-minute peak power).

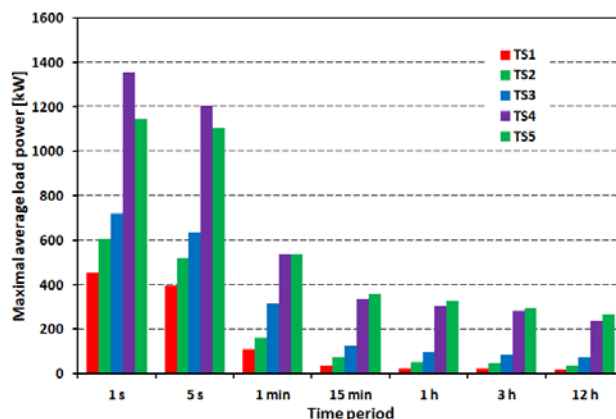

Fig. 3. The maximal value of average load of traction substation in function of averaging period

It should also be mentioned that the contracted 15-minute power depends on the maximal peak power (1-sec). This is due to the technical requirements for the power supply line and the billing system. In practice, contracted 15-min power cannot be less than 20-40% of peak power. Fig. 4 presents the same indicators as Fig. 3, but using normalized values. The base value of a load was selected as the maximal 1-hour average load, individually for each substation. From the figure, it can be clearly seen that, unlike railway traction [14], the differences between the maximum loads for 15-minute, 1-hour and 3-hour intervals are small. In contrast, the difference is substantial when comparing the short-interval loads. It should be noted that the largest load variation, i.e. the difference between 1-hour and 1-second loads, is the largest for traction substations, which supply a small area, i.e. area with small number of vehicles in operation (TS1, TS2 and TS3 in Fig. 4).

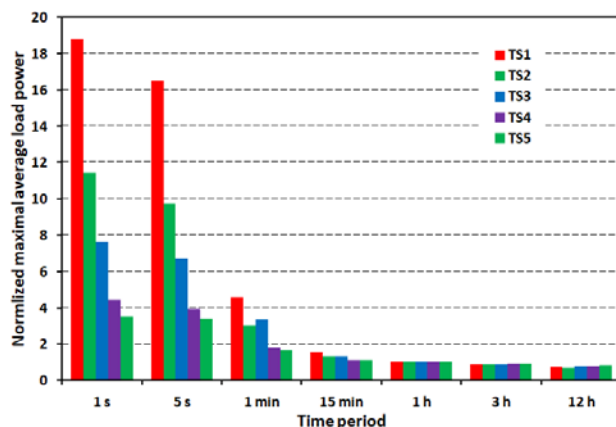

Fig. 4. The maximal value of average load of traction substation as a function of averaging period normalized to the 1-hour maximal value

The large difference between the peak load and its long-period values makes it necessary to oversize traction substation equipment (e.g. transformers, rectifiers etc.), and above all to oversizing the power supply line. This brings the need to incur higher fees for connection fee and contracted power from energy supplier.

For standard traction substations (Fig. 5a), traction energy is drawn from the AC supply line by the rectifier unit and DC switchgear. In case of low density of traffic in supply section the ratio between peak load value and average load is very high, which requires oversizing of the traction transformer and AC supply line. To avoid that, an energy storage system may be used to suppress the values of short-interval power demands (Fig. 5b). In such a case, the supply section is powered both from the standard rectifier and from the energy storage (supercapacitor or battery) through a DC/DC converter. The storage system is charged with a relatively small power from the AC network. The collected energy is then used to cover the short-interval high-value load demand that normally would have been serviced by the rectifier. The output DC/DC converter may also be used as the overcurrent protection of DC catenary, which allows substantial simplification of the DC switchgear.

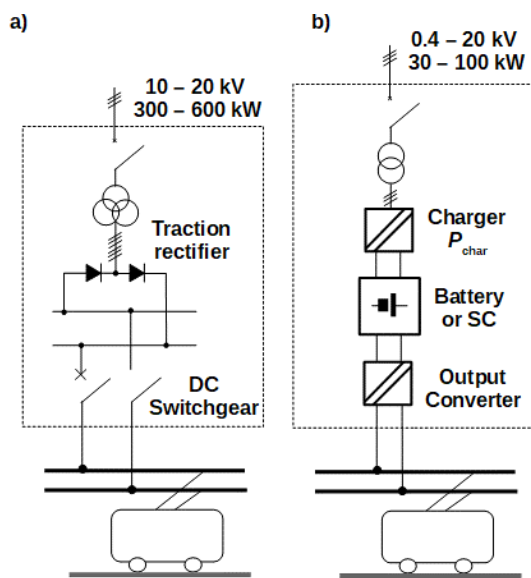

Fig. 5. Standard traction substation (a) and Storage Energy System with low power charging from AC network (b);  $P_{char}$  – charging power of SES

Fig. 6 shows a diagram of the proposed calculation algorithm for determining the required SES capacity in regard to the desired charging power. It is based on the registration of the load of traction substation  $P_{TS}(t)$  and the determination of the energy  $E_{SES}$  stored in the energy storage system. The algorithm is repeated until the minimum SES capacity  $C$  is found, enabling load balancing at a given charging power  $P_{charg}$ .

Figure 7 shows the relationship between the required SES capacity and  $P_{char}$  power. The calculation were made for three substations with relatively small supply area: TS1, TS2 and TS3, based on registration of their actual loads.

The use of an SES makes it possible to reduce the peak power consumption of the substation to the level of maximum load in a one-hour scale. In particular, in the case of small substations (such as TS1, TS2), this reduces the power of the AC power line from 300–400 kW to approx. 40 kW. This results in a significant reduction in the fee for contracted

power, and in the case of constructing a new substation reduces the costs of building a power line.

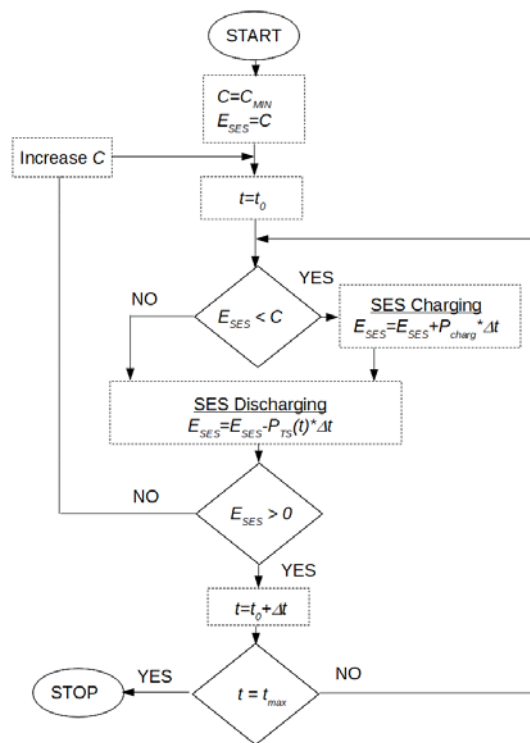

Fig. 6. The scheme of calculation algorithm,  $C$  – the capacitance of SES,  $E_{SES}$  – actual energy accumulated in SES,  $P_{TS}(t)$  – actual the load power of substation (from real load registration),  $t_{max}$  – length of the load registration

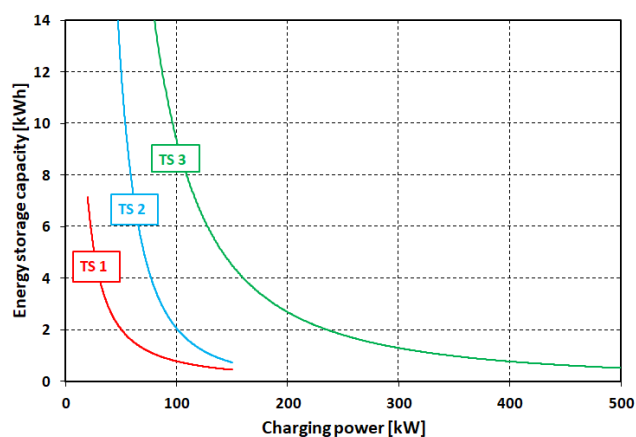

Fig. 7. Calculation outcomes – SES capacity vs. charging power for substations TS1, TS2 and TS3

Concluding from the analysis above, the energy storage should have the capacity between 5 and 15 kWh. Such a level of capacity determines the type of energy storage as electrochemical batteries. Due to the high peak power consumption and high frequency of charge and discharge cycles, lithium-titanate (LTO) batteries are the preferred solution. Beside capacity, the battery needs to provide high peak power of a value 400–800 kW. LTO batteries can be discharged at 10–15 C, which requires batteries with a capacity of 40–80 kWh

### III. SES IN TRACTION PV SUPPLY SYSTEM

Solar energy is considered as a promising renewable source for electrified transport systems. However, the variability of the load, especially on a short-term scale, limits the possibility to utilize the energy generated by the photovoltaic system. At periods of low load, the generated power would remain unused. In turn, covering the high loads would require installing photovoltaic panels of substantial rated power. Fig. 8 compares the load of the traction substation TS5 and exemplary energy generation profile for a 500 kW photovoltaic system on an hourly scale. This clearly depicts the above-mentioned problems.

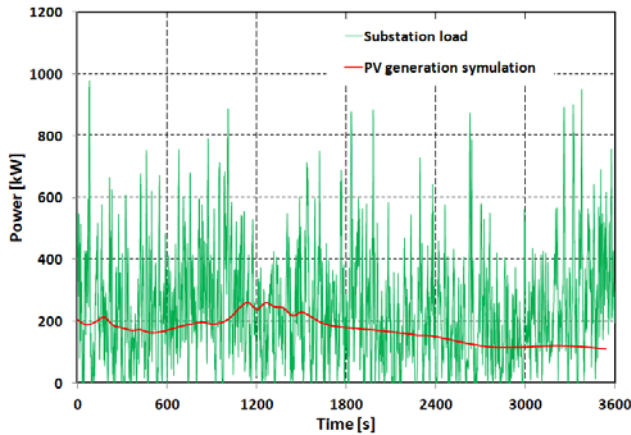

Fig. 8. Load chart of substation TS5 on an hourly scale and a sample energy generation profile of the PV system rated for 500 kWp [15]

PKT Gdynia is planning to build a photovoltaic system on the roof of the buildings of the trolleybus depot in Gdynia [15]. The generated energy will supply the trolleybus' catenary.

As evaluated in [15], the generated solar energy would be used only in 75%. The solution proposed there provides the transfer of generated energy directly to the traction network, without the possibility of its accumulation. To increase this factor, the installation of an additional storage energy system is considered. SES would accumulate the generated energy in times of no energy consumption in the traction network. Figure 9 presents the structure of supply system with SES.

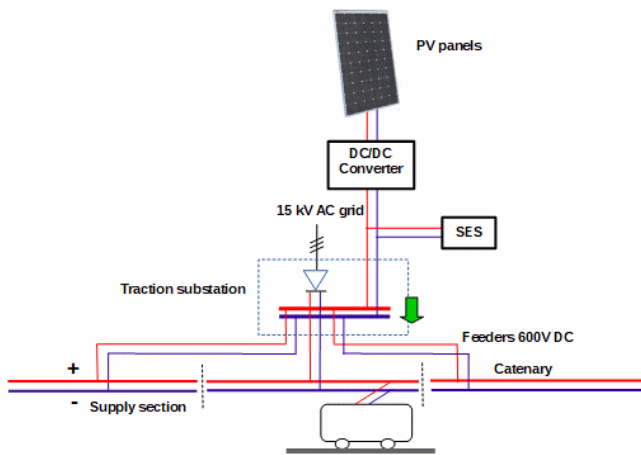

Fig. 9. The scheme of trolleybus supply system with PV plant

Based on recordings of the traction substation load and the scaled daily generation profile of the PV system, calculations of required energy storage capacity were carried out. In order to reflect the local conditions of sunlight, the simulation of the PV system was based on measurements of the existing photovoltaic system in northern Poland with the power of 33 kW [15]. The calculations were made PV system in three variants of its peak power: 500 kW, 750 kW and 1000 kW. Fig. 10 shows a diagram of the proposed calculation algorithm. Based on the relationship between the energy generated by the photovoltaic system  $P_{PV}(t)$  and the energy of the substation load  $P_{TS}(t)$ , SES status (charging - discharging) is determined and energy ESES stored in energy storage system is calculated.

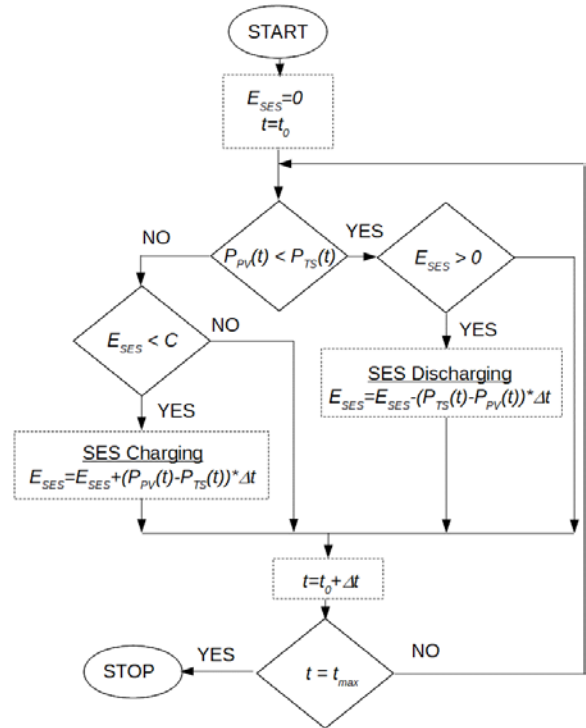

Fig. 10. The scheme of calculation algorithm,  $C$  – capacitance of SES,  $E_{SES}$  – actual energy accumulated in SES,  $P_{TS}(t)$  – actual the load power of substation (from real load registration),  $P_{PV}(t)$  – actual generated power of PV installation (from scaled real load registration),  $t_{max}$  – length of the load registration

Fig. 11 shows annual solar energy generation as the function of storage energy capacity. Fig. 12 shows the annual utilization of solar energy as a function of SES capacity. Both Fig. 11 and Fig. 12 include the three variants of peak power of the PV system. Application of SES increases utilization of the photovoltaic system for supplying the traction power supply system. This impact is visible on a short-term and long-term scale (Figure 12). In the short-term scale, the SES allows to accumulate generated energy when most of vehicles do not move or move in the drive-off mode. Increasing efficiency on a long-term scale consists in adjusting the PV system to the daily variability of energy reception in the traction system (morning peak - afternoon peak).

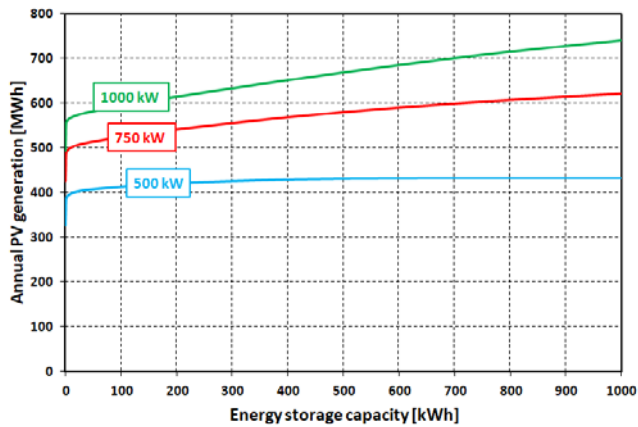

Fig. 11. Annual energy generation in the function of capacity of energy storage systems, for different installed PV systems

If a 500-kW PV system is installed, which is close to the one-hour substation load, installing a 1-kWh storage energy system allows you to increase the degree of usage of the solar plant's potential from 75% to 90%. This is a result of load equalization on a short-term scale. In the case of installing a higher capacity photovoltaic system, it is necessary to balance the load on a long time scale, which requires the use of a storage tank with a capacity of 200–1000 kWh. In this case, it is necessary to use high-capacity electrochemical batteries and the economic sense of such investment may be questionable.

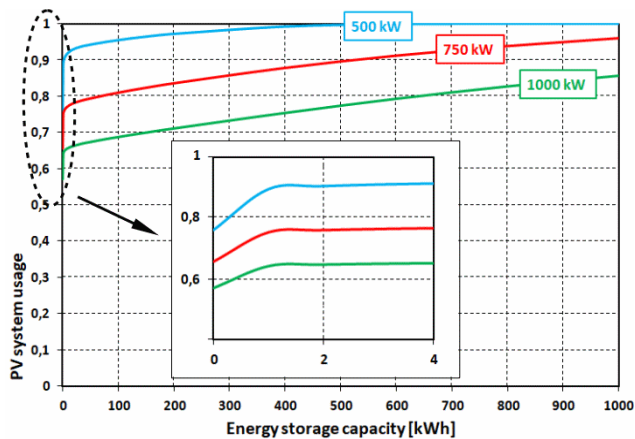

Fig. 12. Utilization of the energy generation potential as a function of capacity of energy storage systems, for different installed PV systems

#### IV. CONCLUSION

The article discussed two innovative applications of energy storage system in power supply systems for electrified urban transport. The considered applications have different aims – reducing the peak power demand of a traction substation or optimizing the utilization of solar energy related to the mismatch between generated and load power. Both applications are expected to provide economic benefits. The second one increases the use of green energy, so it also brings the ecological gain.

Algorithms for calculating the optimal capacity of SES in the considered applications were presented and used for exemplary cases. Using real measured data analysis have been

done giving interesting results. The presented solutions can be elements of a smart grid DC traction supply system.

#### REFERENCES

- [1] M. C. Falvoa, R. Lamedica, R. Bartoni, G. Maranzano, Energy management in metro-transit systems: An innovative proposal toward an integrated and sustainable urban mobility system including plug-in electric vehicles, *Electric Power Systems Research*, vol. 81, pp. 2127–2138 (2011)
- [2] M. Donno, A. Ferrari, A. Scarpelli, P. Perlo and A. Bocca, "Mechatronic system for energy efficiency in bus transport," 2012 Design, Automation & Test in Europe Conference & Exhibition (DATE), Dresden, 2012, pp. 342-343.
- [3] J. Kubín and Ž. Ferková, "Influence of driving style of a tram driver on the tram's energy consumption," 2015 International Conference on Electrical Drives and Power Electronics (EDPE), Tatranska Lomnica, 2015, pp. 417-421.
- [4] Z. Xiao, X. Feng, Q. Wang and P. Sun, Eco-driving control for hybrid electric trams on a signalised route, *IET Intelligent Transport Systems*, vol. 14, no. 1, pp. 36-44, 1 2020.
- [5] M. Bartłomiejczyk, S. Mirchevski, L. Jarzebowicz and K. Karwowski, "How to choose drive's rated power in electrified urban transport?," 2017 19th European Conference on Power Electronics and Applications (EPE'17 ECCE Europe), Warsaw, 2017, pp. P.1-P.10.
- [6] G. Stana and V. Brazis, "Modeling of two-trolleybus motion with braking energy exchange and transmission resistance," 2018 25th International Workshop on Electric Drives: Optimization in Control of Electric Drives (IWED), Moscow, 2018, pp. 1-6.
- [7] E. Sindi, L. Y. Wang, M. Polis, G. Yin and L. Ding, Distributed Optimal Power and Voltage Management in DC Microgrids: Applications to Dual-Source Trolleybus Systems, *IEEE Transactions on Transportation Electrification*, vol. 4, no. 3, pp. 778-788, Sept. 2018.
- [8] M. Bartłomiejczyk, "Practical application of in motion charging: Trolleybuses service on bus lines", 18th International Scientific Conference on Electric Power Engineering, 17-19.5.2017, Kouty nad Desnou, Czech Republic.
- [9] M. Bartłomiejczyk, S. Mirchevski S, "Reducing of energy consumption in public transport - results of experimental exploitation of super capacitor energy bank in Gdynia trolleybus system", 16th International Power Electronics and Motion Control Conference and Exposition (PEMC), 2014.
- [10] M. Bartłomiejczyk, "Super capacitor energy bank MEDCOM UCER-01 in Gdynia trolleybus system". IECON 2016 - 42nd Annual Conference of the IEEE Industrial Electronics Society, 2016, pp. 2124 - 2128
- [11] M. Bartłomiejczyk, "Modern technologies in energy demand reducing of public transport – Practical applications". Zooming Innovation in Consumer Electronics International Conference (ZINC), 31.05-1.06.2017, Novi Sad, Serbia, DOI: 10.1109/ZINC.2017. 7968665
- [12] V. Calderaro, V. Galdi, G. Graber, A. Piccolo, A. Capasso, R. Lamedica, A. Ruvio, "Energy Management of Auxiliary Battery Substation Supporting High-Speed Train on 3 kV DC Systems", In Proc. 4th International Conference on Renewable Energy Research and Applications (ICRERA), Italy, Palermo, 22-25 Nov. 2015, pp. 1224 – 1229.
- [13] K. Hebel, M. Wołek, Perception of modes of public transport compared to travel behaviour of urban inhabitants in light of marketing research, *Scientific Journal of Silesian University of Technology. Series Transport*, 2016, 92, 65-75. ISSN: 0209-3324.
- [14] M. Jarnut, J. Kaniewski and V. Protsiuk, "Energy storage system for peak-power reduction of traction substation" 2018 Innovative Materials and Technologies in Electrical Engineering (i-MITEL), Sulecin, 2018, pp. 1-5.
- [15] M. Bartłomiejczyk, Potential application of solar energy systems for electrified urban transportation systems, *Energies*, Vol. 11, iss. 4, pp.1-17, 2018, DOI: 10.3390/en11040954