

1        **A comprehensive review on Ginger (*Zingiber officinale*) as a potential**  
2        **source of nutraceuticals for food formulations: Towards the polishing of**  
3        **gingerol and other present biomolecules**

4  
5        Clarissa Garza-Cadena<sup>1</sup>, Daniela Marian Ortega-Rivera<sup>2</sup>, Gerson Machorro-García<sup>1</sup>,  
6        Eloy Mauricio Gonzalez-Zermeño<sup>2</sup>, Diego Homma-Dueñas<sup>1</sup>, Roberto Castro-Muñoz<sup>3, 4\*</sup>

7  
8        <sup>1</sup>*Tecnológico de Monterrey, Campus Monterrey, Av. Eugenio Garza Sada Sur 2501 Sur, Tecnológico,*  
9        *64849 Monterrey, N.L., México*

10  
11        <sup>2</sup>*Tecnológico de Monterrey, Campus Ciudad de México, Prol. Canal de Miramontes, Coapa, San Bartolo*  
12        *el Chico, Tlalpan, 14380 Ciudad de México, CDMX, México*

13  
14        <sup>3</sup> *Gdansk University of Technology, Faculty of Civil and Environmental Engineering, Department of*  
15        *Sanitary Engineering, 11/12 Narutowicza St., 80-233, Gdansk, Poland*

16  
17        <sup>4</sup>*Tecnológico de Monterrey, Campus Toluca. Av. Eduardo Monroy Cárdenas 2000 San Antonio*  
18        *Buenavista, 50110 Toluca de Lerdo, Mexico*

19  
20        E-mail: [food.biotechnology88@gmail.com](mailto:food.biotechnology88@gmail.com) ; [castromr@tec.mx](mailto:castromr@tec.mx)

21  
22  
23  
24 -----  
25 \*Corresponding Author  
26

27 **Abstract**

28 Currently, ginger is one the most consumed plants when dealing with the treatments of  
29 various illnesses. So far, it is known that various biologically active molecules, such as  
30 gingerols, shogaols and zingerone, among others, are the main responsible for specific  
31 biological activities, opening a new window for its utilization as a nutraceutical in foods.  
32 In pioneering extraction processes, solvent extraction has been initially used for these  
33 applications; however, the drawbacks of this typical extraction method compared with  
34 other emergent separation techniques make it possible for the exploration of new  
35 extraction pathways, including microwave, ultrasound, supercritical, subcritical and  
36 pressurized-assisted extraction, along with three phase partitioning, high-speed counter  
37 current chromatography and magnetic solid phase extraction. To the best of our  
38 knowledge, *there is no report documenting the recent studies and cases of study in this*  
39 *field*. Here, we review the progress of the current research developments, focused on  
40 meaningful outcomes and strategies.

41

42 **Keywords:** *Ginger, metabolite purification, nutraceuticals, gingerol, shogaol.*

43

44

45 **Abbreviations:**

46 CO<sub>2</sub>: carbon dioxide

47 GNs: Gingerols

48 HSCC: Subcritical water extraction

49 MAE: Microwave-assisted extraction



50 MSPE: Magnetic solid phase extraction

51 PLE: Pressurized liquid extraction

52 SCFE: Supercritical fluid extraction

53 SWE: Subcritical water extraction

54 TPP: Three phase partitioning

55 UAE: Ultrasonic-assisted extraction

56

## 57 **1. Introduction**

58 Nutraceuticals are natural biomolecules that do not require complex processes for  
59 its production; they are typically obtained from natural products whether they are plant,  
60 mineral or animal based. Often, they are utilized as a food supplement in the form of  
61 powder or pills without being considered pharmaceutical drugs, as they do not assure that  
62 the component is completely effective in dealing with a disease or condition. Mostly, they  
63 are used as an alternative to prevent specific conditions, which will require medication if  
64 the person consuming them does not take care of their health. Products, such as punicic  
65 acid and whey protein, are examples of these nutraceuticals as they have specific needs  
66 for their target audience (López Flores et al., 2016). Punicic acid, for instance, is a food  
67 supplement for diabetics as it can help express mechanisms that can reduce glucose  
68 levels, preventing the need for aggressive drugs like metformin. On the other hand, whey  
69 protein helps bodybuilders and athletes fulfill their protein intake after exercise to build  
70 muscle mass. Since nutraceuticals do not require medical intervention to be administered,  
71 there is a current need for searching different types of sources of these components. It is  
72 likely that ginger is one of the most used natural products by society due to its content of

73 phytochemicals, which could be used to extract a wide variety of nutraceuticals. Likewise,  
74 Ginger is one of the most investigated natural sources over the last decades; for instance,  
75 **Figure 1** evidences the continuous effort from the research community, as evidenced by  
76 the number of publications related to this natural source. As can be seen in **Figure 1**, this  
77 natural product may be strongly explored in recent years, which could be associated with  
78 the dietary supplements and nutraceuticals market growth due to the coronavirus  
79 pandemic. In this latter framework, many extracts and their related-bioactive substances  
80 are currently being investigated to face symptoms related to this virus.

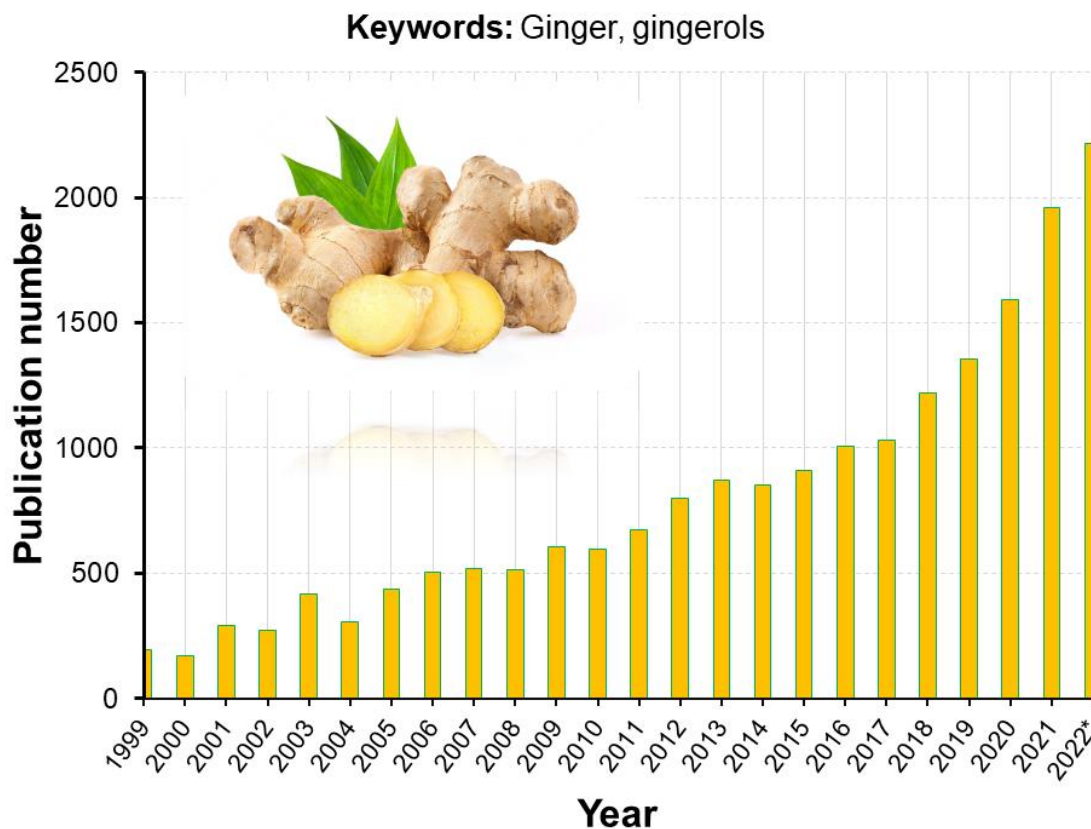

81  
82 **Figure 1.** Documented publications associated with the research towards Ginger over  
83 the last two decades (until October 19th, 2022; source: Scopus). *Keywords:* Ginger,  
84 gingerols

85 Ginger is a plant indigenous to tropical Asia that is now cultivated across the world.  
86 There are records of this root being used for both culinary and medical applications as  
87 well as being noted by other cultures as a useful spice to combat nausea and stomach  
88 related illnesses. The use of ginger, whether in fresh or dried forms, allows for the  
89 treatment of different conditions related to pain. Most of the compounds tend to be  
90 processed to extract what is necessary for the treatment to produce nutraceuticals.  
91 Though, in ancient times, most of the ginger was used as a food additive for treatments  
92 (Semwal et al., 2015).

93 Although ginger is one of the most consumed spices in the world with at least 115  
94 varieties between fresh and dried ginger, the geographical differences between varieties  
95 allows the creation of different compounds. For instance, Ginger contains gingerol,  
96 chemically known as [6]-gingerol, which displays a nutraceutical effect. This biomolecule  
97 is identified as a phenol phytochemical compound found in fresh ginger that activates  
98 spice receptors on the tongue. Gingerols are associated with the alleviation of nausea,  
99 arthritis, and pain; while some of these gingerols have a specific role helping in the  
100 treatment of diabetes and various tumours (Yulianto et al., 2020). While these properties  
101 are being studied in different cell lines rather than tested on humans, they set a precedent  
102 for investigating the ginger itself. Gingerol compounds are thermally labile and transform  
103 at high temperature into shogaols which serve to create biomarkers for ginger related  
104 products. Gingerols have a high commercial value that pushes the development of  
105 different ways to biosynthesize and extract them. Therefore, experimenting on different  
106 extraction methods seems to be the most friendly and efficient pathway of obtaining them  
107 from their natural source (Yulianto et al., 2020). In this review, we analyse the current

108 developments, ideas and methods for extracting gingerols and some other related  
109 biomolecules from ginger, paying attention to the most relevant outcomes and findings.  
110 Considering that most of the Ginger substances are nutraceuticals, a feedback on the  
111 main medicinal and biological activities of such compounds is also given.

## 112 **2. An overview on medicinal and biological activities of Ginger extracts**

113 Acquire the knowledge about ginger extracts and their impact in different fields of  
114 medicine is of utmost importance to provide a conscious about bioprocessing and  
115 biotechnology. This root has been used for different medical purposes, for example,  
116 ginger based infuses are commonly prepared worldwide to alleviate many ills like treat  
117 coughs, colds and flu. In some countries, this specie was mainly used to reduce fatigue,  
118 combat nauseas, prevent rheumatism (especially Indian thought) and improve digestion.  
119 As mentioned previously, ginger is an important source with a high nutraceutical value  
120 because of the variety of bioactive compounds, as shown in **Figure 2**. Several studies  
121 have demonstrated the importance of this root due to the presence of various  
122 biomolecules and their associated biological activity (Semwal et al., 2015). Specific  
123 compounds found in ginger are phenolic and terpene compounds, which are widely  
124 known as bioactive molecules that work as antioxidants, anti-inflammatory, antimicrobial  
125 and symptoms of cancer inhibitor activities. This latter characteristic is one of the most  
126 studied properties because it could be an opportunity to prevent cancer proliferation in  
127 any part of the body, however, it is also important to identify which compounds are the  
128 aim for achieving successful bio-products.

129



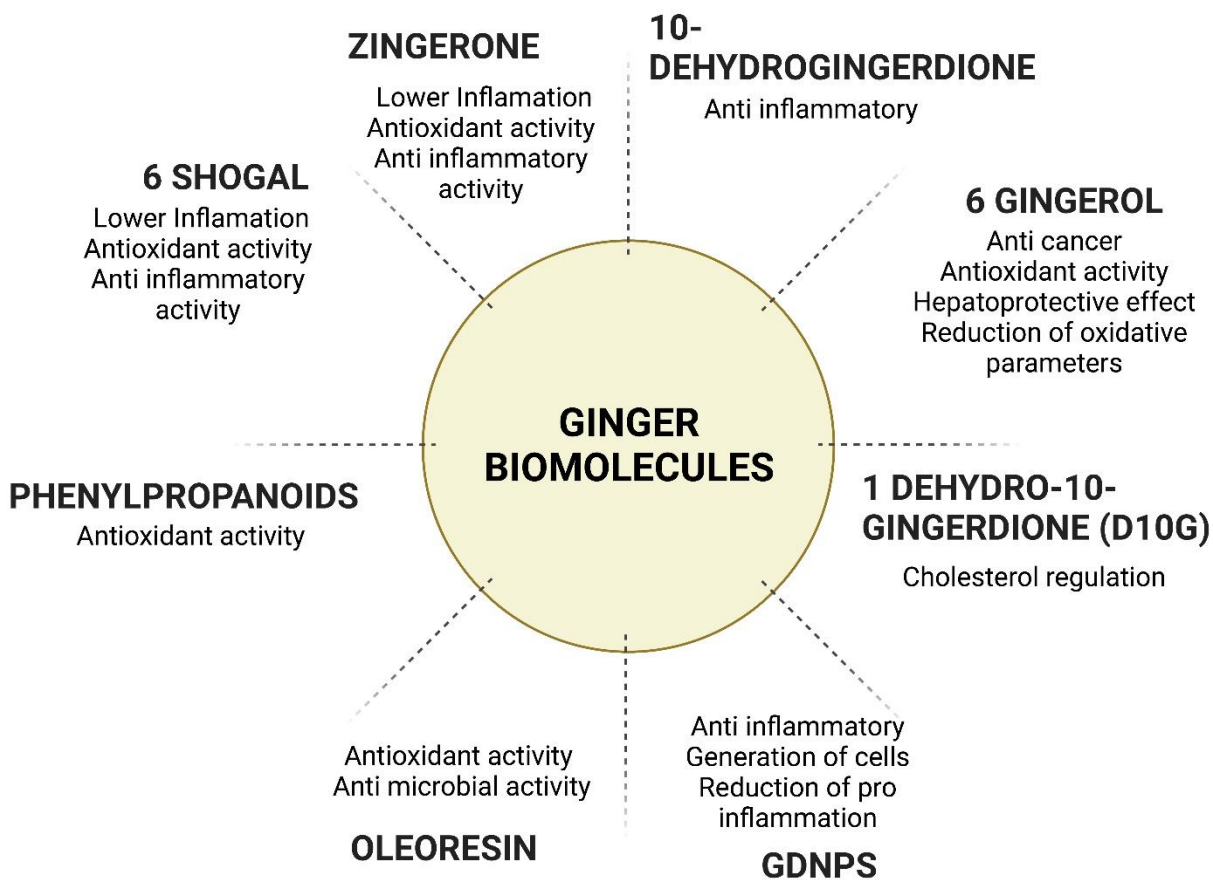

130

131 **Figure 2.** Importance and biological activities attributed to Ginger biomolecules.

132 Among phenolic compounds, there is a specific compound that increases the  
 133 nutraceutical value of Ginger, such as gingerols (GNs). The typical chemical structure of  
 134 GNs which display antioxidative properties and are studied for cancer prevention  
 135 research (Mao et al., 2019).

136 To some extent, mechanism of action of these compounds are still unknown but with  
 137 great potential to be discovered thanks to the evolution of high effective technologies in  
 138 the pharmaceutical industries. For instance, Rahmani et al. reported that in the cancer

139 studies the compounds could give a biological modulation for some activities, such as  
140 antioxidant activity that prevent cell damage, anti-inflammatory which is an important  
141 activity for the modulation of genetic pathways (induction of apoptosis in endometrial  
142 cancer cells), antimicrobial properties against pathogens, among other activities towards  
143 critical diseases like obesity, cancer, diabetes, etc (Rahmani et al., 2014). However, the  
144 authors pointed out that deeper research is needed to recognize and understand each  
145 activity. In general, punctual biological activities have been attributed to the compounds  
146 contained in Ginger, as follows:

147 1. Antioxidative activity: The main role of ginger in the antioxidative activity is to  
148 balance free radicals' production and make a better defence system in humans. It is  
149 also used an *in vitro* evaluation via ferric-reducing antioxidant power aiming the break  
150 of phenolic compounds in the cell associated to phenolic contents after heated (Mao  
151 et al., 2019). Important compounds of ginger that work as an antioxidant factor are the  
152 flavonoids which are studied for reducing symptoms like vomit and nauseous in  
153 patients involved in chemotherapy sessions. This has been demonstrated by *in vitro*  
154 studies (Danwilai et al., 2017). Rahmani et al. reported that besides that ginger helps  
155 as a radical free production inhibitor, it also plays a role in reduction of lipid oxidation  
156 while acting as an important precursor for lipid oxidation to prevent gastrointestinal  
157 ills. Also, essential oils of ginger containing 6-dehydrogaol, 6-shogaol and 1-  
158 dehydro-6-gingerdione can bring antioxidative activities, which act as nitric oxide  
159 inhibitor and degrades macrophages (Rahmani et al., 2014).

160 2. Anti-inflammatory activity: There are several compounds that act as an anti-





161 inflammatory precursor for muscle contractions. Ginger oil has revealed such a  
162 characteristic, preventing the repression of paw associated with arthritis. For example,  
163 studies demonstrate that cytokines acquired in ginger, such as interleukin-1 (IL-1) and  
164 IL-8, are inhibitors in the pathway for inflammatory precursors. The main compounds  
165 are based on zingerone and gingerol related compounds (Rahmani et al., 2014).  
166 Additionally, ginger root has been used worldwide in plenty of countries to treat  
167 arthritis, muscular discomfort, and inflammation (Semwal et al., 2015).

168 3. Antimicrobial activity: It is known that some compounds formed in ginger root are  
169 precursors for inhibition the proliferation of bacteria, fungi, and viral infections, which  
170 may lead to chronic diseases or antimicrobial resistance. Specific lipophilic ginger  
171 compounds permit the disintegration of cell membrane thanks to the permeable phase  
172 in which the compound attaches. In the case of viruses, ginger compounds block the  
173 attachment of viral organisms and then their inhibition (Mao et al., 2019). In a recent  
174 study, it was demonstrated that ginger rhizome is a great compound for microbial  
175 inhibition thanks to its constitution and related attachment to some bacterial cell  
176 membrane (Rahmani et al., 2014).

177

178

179

180



**Table 1.** Biomolecules present in Ginger and their related biological activities.

Molecule	Concentration	Biological activity	Remark of the study:	References:
6-gingerol	5 mg per pill. 2 pills prior to chemotherapy	Antioxidant activity. Reduction in oxidative parameters.	Antioxidative parameters CuZn-SOD, CAT, GPx and GSH/GSSG increased, while xidant parameters MDA, NO <sub>2</sub> - /NO <sub>3</sub> - declined.	(Danwilai et al., 2017)
	N/A*	Anticancer activity	Cell death in mutant p53-expressing cells by apoptosis and cell cycle arrest.	(Park et al., 2006)
	(30 mg/kg) orally	Hepatoprotective effect	Lowering of AST, ALT, ALP and bilirubin (hepatic marker enzymes). Maintained hepatic malondialdehyde formation from elevating.	(Sabina et al., 2011)
6-Shogaol	100 mg/kg of 6-Shagol	Antioxidant potential where Nrf2 target genes were activated.	6-Shagol activates Nrf2 in colon epithelial cells (in vitro and in vivo) and can be used for colonic diseases.	(H. Chen & Wang, 2017)
	N/A	Anti-inflammatory activity due to nitric oxide inhibition in macrophages.	Inhibition of the NF-κB activation in macrophage demonstrated that activities are structure-dependent of ginger compounds.	(Li et al., 2011)
	N/A	Reduction of inflammation in the lungs and airway hyperresponsiveness.	Treatment for asthma due to inflammation reduction.	(Menon et al., 2021)
Oleoresin	2 mg/mL of Oleoresin	Antioxidant and antimicrobial activities. Due to its phenolic compounds.	Low concentrations of oleoresin are needed to obtain its antioxidant and antimicrobial activity. The phenolic compounds are responsible for its properties	(Bellik, 2014)



Phenylpropanoids	40 ug/mL of ginger phenylpropanoids.	Antioxidant activity increasing Nrf2 activity in BJ fibroblastic cells	Phenylpropanoids have an effect increasing the level of Nrf2 of BJ cells which demonstrate it could diminish oxidative stress regarding the human skin cells demonstrating they have chemoprotective activity.	(Schadich et al., 2016)
GDNPs	0.3 mg/mouse per day (oral)	Generation of intestinal epithelial cells. Reduction in pro-inflammatory cytokines Increase in anti-inflammatory cytokines in mouse colitis models.	In mouse colitis models there was enhancement of intestinal repair, prevention of inflammation of the intestines, reduction and prevention of colitis. GDNPs 2 were higher in non-starved mice. Potential usage for inflammatory bowel disease.	(Zhang et al., 2016)
Zingerone	N/A	Anti-Inflammatory properties, antioxidative. anti-cancer, antioxidative antidiarrheal, and growth enhancer.	Zingerone inhibits xanthine oxidase enzyme, degrades free radicals minimizing oxidation of lipids. Reduces mitochondrial injury. It also increases phagocytic activity, increases respiratory burst, fights pathogens by inhibiting enterotoxins, great for the conversion of energy due to its lipolytic activity and reduces inflammation and toxicity.	(Ahmad et al., 2015)
10-Dehydrogingerdione	N/A	Cholesterol regulating activity	Dyslipidemic rabbits that were fed 10-dehydrogingerdione had lower LDL cholesterol and higher HDL cholesterol due to the suppression of CETP. Potential treatment for cardiovascular diseases since it reduces oxidative risk and modulates inflammation.	(Elseweidy et al., 2013)
1 dehydro-10-gingerdione (D10G)	N/A	Anti-inflammatory activity.	D10G inhibits activity of IKKB by interacting with Cys bond which leads to the suppression of NFκB which is in charge of inflammatory genes (iNOS, COX-2 or IL-6). Potential use in autoimmune disorders.	(Lee et al., 2012)

182

183

\*N/A: Not Available

184

185



186 2.1. *Past, ongoing and future research towards Ginger*

187 One of the first scientific reports documented on Ginger (*Zingiber officinale*) was in the  
188 year 1990 where Fischer-Rasmussen used 250 mg of powdered ginger to see its effect  
189 in nausea and vomiting in pregnant women (Anh et al., 2020). This study concluded that  
190 ginger was effective in preventing excessive nausea and vomiting in women who were in  
191 their first trimester (Fischer-Rasmussen et al., 1991). According to a study published by  
192 Anh and colleagues, the effect of ginger on human health has been mostly positive,  
193 proving effective in improving digestive function, anti-inflammatory effects, pain,  
194 metabolic syndrome, and symptoms. Currently ginger is being researched on its  
195 anticancer activity and chemotherapy effects. Furthermore, Kumar and colleagues reveal  
196 studies in the future related to inflammatory properties against anaemia disorders. It is  
197 proposed to develop an anti-inflammatory drug that is based on the activation of blocker  
198 agents that suppress the NF-kB cytokinin to prevent this symptom. For chemotherapy,  
199 drugs based on ginger bio compounds could represent a great opportunity to research  
200 and development and according to the same study made in 2013, natural products and  
201 their derivatives will represent a 50% of all drugs used in clinical cases. However, it also  
202 could represent some disadvantages, for example, with all the changes that the planet is  
203 suffering the quality and control of plants represent a lack of standardization and efficacy  
204 in drug development. It is also important to notice that some climate changing reasons  
205 could lead to plant extinction (Kumar et al., 2013).

206 On the other hand, some studies reported the potential of this root in medical and  
207 toxicological properties among the ones explained before in this study. This is shown, for  
208 example, in gynaecological surgery to reduce pain and nausea in a random study to 60



209 women. However, it is indeed a development in research because it is important to  
210 consider doses implemented for drug testing (rat model only is required up to 50 mg/kg/d),  
211 therefore, those dosages are still at research development (Rupasinghe & Gunathilake,  
212 2015).

213 Among other properties of medical importance for ginger bioactive compounds, **Table 1**  
214 reports some of the most studied cases in different fields of medicine, including  
215 gastrointestinal diseases, cancer treatments and antimicrobial processes. It is important  
216 to consider that the doses of each case for the prevention of cytotoxicity, which is typically  
217 ascribed to high doses in the patient body. Considering the promising future of ginger  
218 biomolecules in several health concerns, the research community is focused on different  
219 pathways to either extract or purify target biomolecules from this specie. Therefore, the  
220 following section is devoted to elucidating the advances towards the extraction and  
221 purification of gingerols and many other bioactive substances.

222

### 223 **3. Up-to date strategies towards the extraction and purification of gingerols** 224 **and other bioactive substances from Ginger**

225 Knowing the extensive content of bioactive substances of Ginger, this natural source has  
226 been subjected to distinct separation techniques for the extraction and purification of  
227 particular GNs, including 6-gingerol, 6-Shogaol, 1-dehydro-10-gingerdione, 10-  
228 Dehydrogingerdione, zingerone, and also other substances, such as phenylpropanoids,  
229 oleoresins, etc. In this regard, various separation techniques have been proposed over  
230 the recent years, being solvent extraction the pioneering option in this field. However, as  
231 chemistry and chemical engineering evolve, emerging extraction techniques have been



232 developed and thus evaluated in the extraction of ginger molecules, as illustrated in  
 233 **Figure 3.**

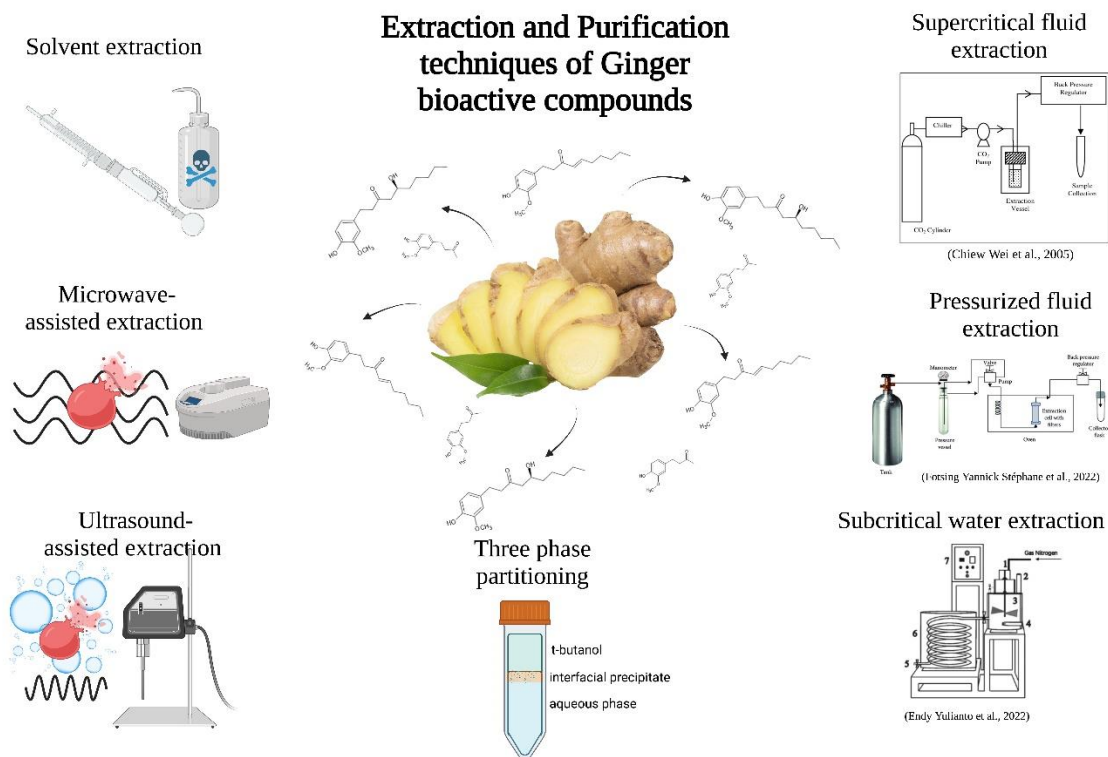

234  
 235 **Figure 3.** Classic and emerging extraction techniques used for the extraction and  
 236 purification of Ginger biomolecules.  
 237

238 To date, microwave, supercritical & subcritical, pressurized fluid and ultrasound assisted  
 239 techniques are among the main emerging tools used within the strategies for the  
 240 extraction of bioactive substances. The following sub-sections reveal an update on  
 241 applying such techniques in Ginger extracts.

242 **3.1. Solvent extraction**

243 Since ancient times, organic solvents have been used for the recovery of bioactive  
244 compounds from plants, which have been used in traditional medicine. Solvent extraction  
245 technique is based on the transference of analytes (compounds) from one solvent to  
246 another, ascribed to the difference in solubility or distribution coefficient (H. Chen & Wang,  
247 2017). This method offers high selectivity, low energy consumption and continuous  
248 operation. However, the utilization of organic solvents can lead to the degradation of the  
249 target compounds, while the extraction times are relatively long, requiring large volumes  
250 and high purity reagents; in addition to this, organic solvents exhibit high toxicity for  
251 human beings while provoking environmental issues.

252 Many authors use solvent extraction techniques for many purposes according to different  
253 needs, such as desired product, shortening of the extraction time, slurry to solvent ratio,  
254 temperature, etc (Castro-Muñoz, Gontarek-Castro, et al., 2022). **Table 2** enlists the  
255 current studies reporting the successful extraction of distinct biomolecules from ginger,  
256 such as gingerol, zingerone, zingiberene, flavonoids, among many others. In a recent  
257 study provided by Keosaeng and co-workers, they compared different solvents to extract  
258 gingerols and shogaols from ginger rhizome. As part of the main outcomes, hexane  
259 achieved the highest recovery yield of ginger extract. The isolated bioactive compounds,  
260 such as 8-shogaol and 10-shogaol, were utilized as insecticidal against *Spodoptera spp.*  
261 larvae, obtaining a LD<sub>50</sub> of 9.92 and 8.40 µg/larva after 24 and 48 h, respectively  
262 (Keosaeng et al., 2022). Interestingly, 8-shogaol and 10-shogaol displayed the highest  
263 mortality towards the assayed insect, which did not vary significantly after 24 h assay, as  
264 illustrated in **Figure 4**.



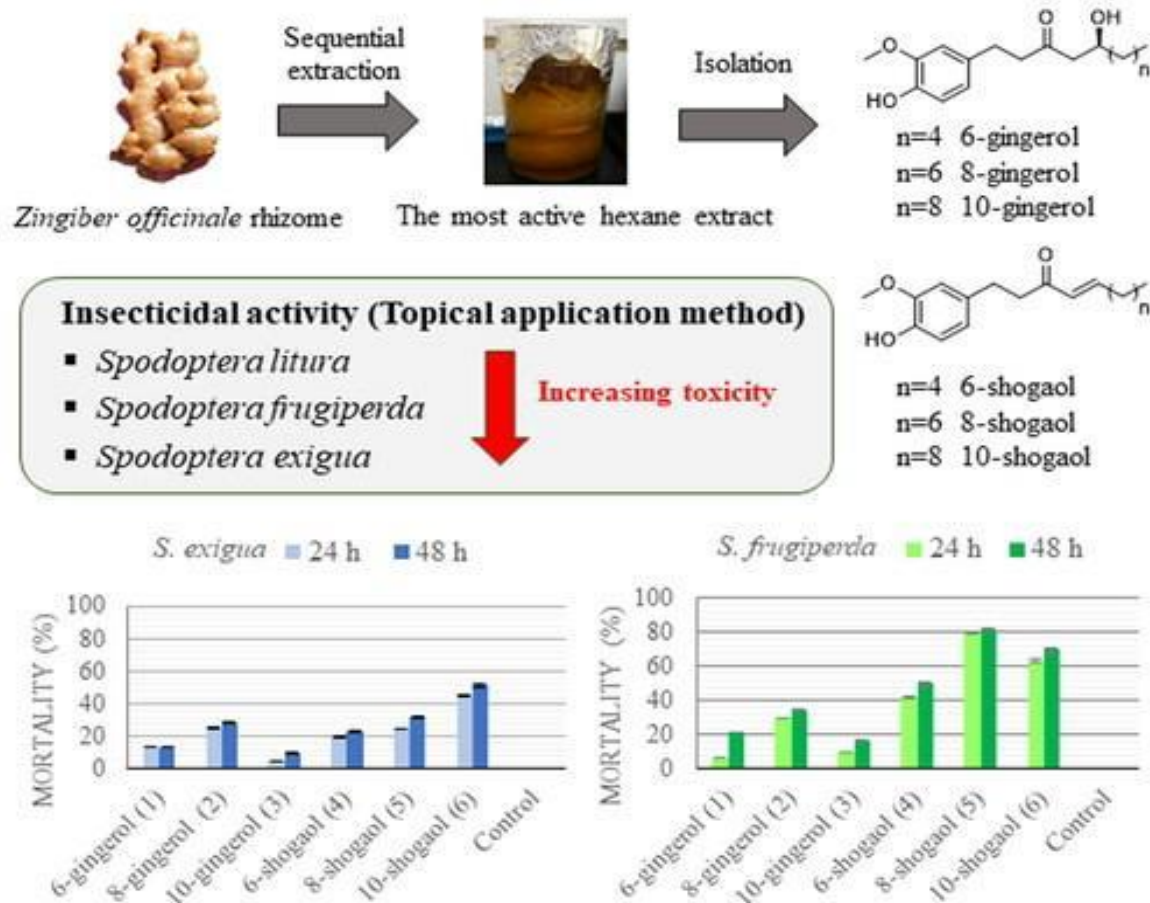

265

266 **Figure 4.** Isolation of gingerols and shogaols from ginger using solvent extraction

267 (Keosaeng et al., 2022).

268

269

### 3.2. Supercritical fluid extraction

270 Supercritical fluid extraction (SCFE) is one of the available techniques that may potentially

271 replace the traditional organic solvent extraction technique, due to the achievement of a

272 homogeneous phase after evaporation of the gas phase and separation of the liquids

273 beyond their critical point (Mesomo et al., 2012). The supercritical phase helps the

274 transformation of the fluid into a super solvent, which increases the extraction efficiency.



275 In the extraction process, the diffusion coefficients of lipids and waxes in supercritical  
276 fluids are much higher compared to liquids, shortening the extraction time. In addition,  
277 supercritical viscosity values and diffusion coefficients are between liquids and gases, so  
278 there is low surface tension and increased mass transfer rates (Salea et al., 2017). It also  
279 eliminates the use of organic solvents, which reduces storage, disposal, and  
280 environmental concerns. For instance, some supercritical fluids currently being explored  
281 for extraction are ethylene, carbon dioxide (CO<sub>2</sub>), ethane, methanol, ethanol, benzene,  
282 toluene, and water. In a successful application of this technology, Shukla et al. optimized  
283 the fluid extraction conditions using CO<sub>2</sub> as a supercritical fluid. Interestingly, two  
284 extractors were operated at lab scale and one commercial, as schematized in **Figure 5**.  
285 Finally, the optimal supercritical CO<sub>2</sub> fractionation conditions resulted in a yield of 5.95%  
286 oleoresin, which had a purity of 96.15% and 51.2 wt.% in separator 1 operating at 175  
287 bar and 40 °C. In the second scenario, a 2.71% yield of volatile oil with a purity of 95.94%  
288 was recovered at 40 bar and 40 °C (Shukla et al., 2019). R. Swapna et al. carried out a  
289 study for the characterization and extraction of the active components of ginger, in which  
290 supercritical CO<sub>2</sub> at 280 bar and 40°C were found as optimal conditions. Substances,  
291 such as 4-,6-,10-gingerols, were extracted with a yield of 4.54, 75.92, and 13.15%,  
292 respectively, and a total yield of 34.5% for 6- shogaols was reported. Also, oleoresin was  
293 extracted with a yield of 4.8 % (Swapna Sonale & Kadimi, 2014).

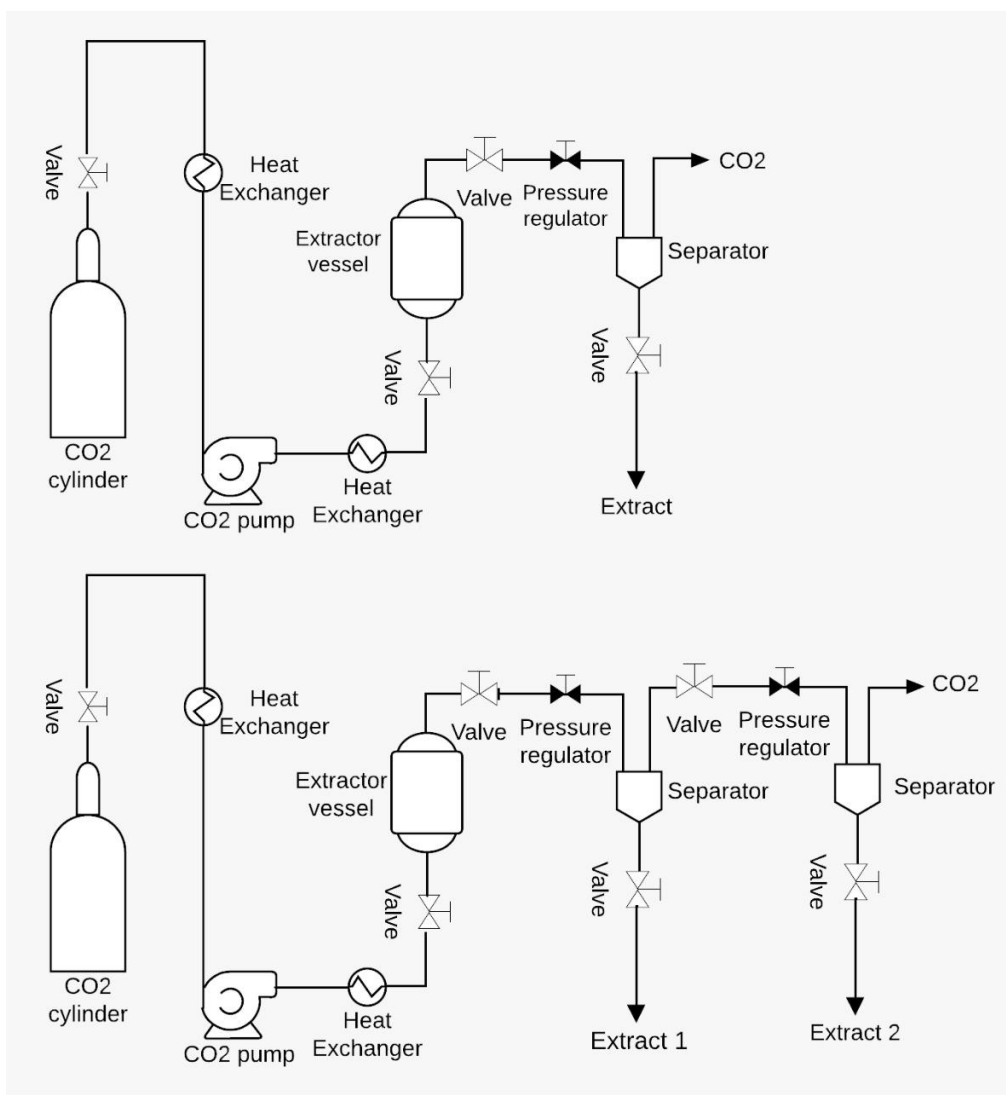

294

295 **Figure 5.** Laboratory scale (top) and commercial (bottom) SCFE plant (Shukla et al.,

296

2019).

297 In a study conducted by Said and co-workers, two different methods of oleoresin

298 supercritical CO<sub>2</sub> extraction were compared, the first one assisted with ultrasound

299 operated at 35 °C and 250 bar, resulting in a yield of 8.15%, while the second one, in

300 which only supercritical CO<sub>2</sub> was used at conditions of 40 °C, 250 bar and 15 g/min of

301 CO<sub>2</sub> flow rate, revealed a yield of 6.87% (Said et al., 2015). It can be assumed that the

302 combination of two extraction methods assisted with supercritical fluids can improve the  
303 extraction of active compounds from ginger. In 2017, Salea et al. conducted an  
304 experiment on ginger oil extraction. The 6-gingerol content in ginger oil was investigated  
305 with operating values in the range of 10-15 MPa, 35-45°C, and 10-20 g/min. The highest  
306 oil yield of 3.10%, along with the highest 6-gingerol content in ginger oil extract with a  
307 yield of 20.69%, were achieved at 15 MPa, 35 °C, and 15 g/min. Under optimum  
308 conditions, the SCFE of ginger oil increased with the highest oil yield of 3.83% while giving  
309 the lowest 6-gingerol content of approximately 18% (Salea et al., 2017).

### 310 3.3. Microwave-assisted extraction

311 Microwave-assisted extraction (MAE) is a novel extraction technique commonly proposed  
312 due to its effectiveness and simplicity when separating compounds from natural sources  
313 (Castro-Muñoz, Díaz-Montes, et al., 2022) . It uses microwave radiation along with distinct  
314 solvents, such as water, methanol, and ionic liquids, to evaporate residual water from the  
315 material. The heat and the solvents that are in contact with the solid or liquid samples  
316 promote the partitioning of the compounds of interest from the sample into the solvent  
317 (Bener et al., 2022). One of its main advantages compared with the conventional methods  
318 is the reduction of time and solvent quantity needed for the extraction; surprisingly, it is  
319 possible to perform MAE without adding solvents (Routray & Orsat, 2019). MAE can be  
320 used to extract pigments, lipids, and bioactive molecules from plants, spices, seaweeds,  
321 microalgae, and oils (Juin et al., 2015). In a study made by Guo et al. in which a MAE  
322 method assisted by ionic liquids was developed to extract 6-, 8-, 10-gingerols and 6-, 8-,  
323 and 10-shogaols from ginger. The results indicated that among the investigated ionic  
324 liquids, (C<sub>10</sub>MIM)Br was found as the optimal. The selected conditions for ionic liquid MAE



325 were at a concentration of 0.80 M (C<sub>10</sub>MIM)Br, with an extraction temperature of 75 °C,  
326 irradiation time of 30 min, and irradiation power of 400 W. The overall yield was reported  
327 as 0.716 % (Guo et al., 2017). Another study performed by Teng et al. showed the MAE  
328 method at different concentrations of solvent, irradiation time, and power to extract 6-  
329 gingerol and 6-shogaol in ginger rhizomes. This resulted in a maximum yield recovery of  
330 28.4% with ethanol 50%, 9 min of irradiation, and 180 W of irradiation power, which  
331 permitted to obtain 3,149 mg/g of 6-gingerol and 1,662 mg/g of 6-shoganol (Teng et al.,  
332 2019). As enlisted in **Table 2**, Liu et al. used MAE to obtain 6-gingerol with optimum  
333 conditions as follows: 528 W of power, ethanol proportion of 78%, and extraction time of  
334 31 seconds with a yield of 15.35 mg/g. Alternatively, MAE was compared with maceration,  
335 ultrasound-assisted extraction, stirring extraction and heat reflux extraction with yields of  
336 7.49 mg/g, 13.38 mg/g and 7.49 mg/g, respectively (Liu et al., 2014).

337

338

339

340

341

342 **Table 2.** Current research and separation techniques aimed for the extraction and purification of bioactive compounds  
 343 from Ginger.

Molecule type:	Technique used	Operating conditions:	%recovery Or concentration	Remark of the study:	References:
6- gingerol 8- gingerol 10-gingerol 6-shogaol 8-shogaol 10-shogaol	Microwave-assisted extraction	0.80M (C10MIM)Br concentration, extraction temperature, 75 °C, irradiation time, 30 min, and irradiation power, 400 W	6-G:0.334 % 8-G:0.086 % 10-G:0.134 % 6-S:0.066 % 8-S:0.036 % 10-S:0.060 %	Microwave extraction was performed in combination with different ionic liquids.	(Guo et al., 2017)
6-gingerol 6-shogaol	Microwave-assisted extraction	Ethanol 50%, irradiation time 9 min and 180 W of irradiation power	Total yield of 28.4% 6-G: 3.149 mg/g 6-S: 1.662 mg/g	The experiment was run at different concentrations of solvent, irradiation time and power.	(Teng et al., 2019)
6- gingerol 8- gingerol 10-gingerol 6-shogaol	Pressurized liquid extraction	70% bioethanol operated at 1500 psi and 100 °C for 20 min	Total yield: 368.8 m'pp'g/g 6-G:14.106 mg/g 8-G:2.627 mg/g 10-G:3.336 mg/g 6-S:0.789 mg/g	PLE is compared to other extraction techniques such as ultrasonic and soxhlet and the results show a significant increase in yield compared with those methods.	(Hu et al., 2011)
6-gingerol	Supercritical fluid extraction	CO <sub>2</sub> , 15 MPa, 35°C and 15 g/min	Total yield of 3.3 % with 22.30 % content of 6-G	It provides a comparison with other extraction methods such as soxhlet and percolation. The supercritical extraction had less yield but a higher 6-G content.	(Salea et al., 2017)





8-shogaol 10-shogaol	Solvent extraction	Solvents: hexane, dichloromethane, ethyl acetate and methanol. 7 L of each solvent, 7 day batch extraction. Filtration and rotary evaporator at 40 °C for removal of solvents.	Extraction yields (wt./wt.) of Hexane 2.12%, Dichloromethane 1.88%, Ethyl acetate 1.17%, and Methanol 1.56%.	Isolated shogaols from ginger rhizome extracts exhibited high toxicity against <i>Spodoptera spp.</i> larvae.	(Keosaeng et al., 2022)
Polyphenols: gallic acid, vanillic acid, ferulic acid; and Flavonoids: quercetin, kaempferol, isorhamnetin, rutin, catechin, caffeic acid	Ultrasound-assisted extraction	Extraction with ethanol, ethyl acetate, acetone and water overnight. Ultrasonication: 15 min, 60 Hz, pulses of 5s on and 3s off, temperature below 35 °C.	15.27% extraction efficiency found in aqueous extract	The ultrasonication method significantly increased the recovery of polyphenols with water as solvent; however, the antioxidant properties require extraction with ethyl acetate or ethanol for better results.	(Jan et al., 2022)
6-gingerol 8-gingerol 10-gingerol	Magnetic solid phase extraction	Graphene oxide/magnetite nanocomposite as sorbent for 8 mL of sample under magnetic stirring.	6-gingerol: 4.0 µg/mg from ginger extract. 8-gingerol: 0.64 µg/mg from tea leaves. 10-gingerol: 0.46 µg/mg from tea leaves.	GO-Fe <sub>3</sub> O <sub>4</sub> nanocomposite was efficiently used for extraction of gingerols from ginger-containing products, achieving high selectivity and accuracy.	(Akamine et al., 2021)
Polysaccharides	Multifrequency ultrasound-assisted extraction	200 W of power, 10 s on with 2 s pause.	Double frequency: 9.74 ± 0.3% Triple frequency: 10.50 ± 0.2%	Dual and triple frequency ultrasound had a significant effect on the yield of polysaccharides extraction. Polysaccharides exhibited functional properties that can be used in the food industry.	(X. Chen et al., 2021)

Flavonoids: rutin, tangeretin, vitexin, isoquercitrin, myricetin-3- glucopyranosi de	High speed counter current chromatography (HSCCC)	<i>n</i> -hexane-ethyl acetate- methanol-water (1:5:1:5 v/v/v/v) at 5 mL/min and <i>n</i> -hexane-ethyl acetate- methanol-water (4:5:4:5 v/v/v/v) at 5 mL/min. Previously purified by a macroreticular adsorption resin.	Rutin 16.6%, tangeretin 13.1%, vitexin 18.37%, myricetin-3-O- glucopyranoside 3.3%, and isoquercitrin 15.2%.	HSCCC could separate five different compounds from a purified sample of flavonoids and achieving; nonetheless two steps were required for an efficient separation.	(L. xia Wang et al., 2022)
Ginger oleoresin: 6-gingerol 8-gingerol 10-gingerol 6-shogaol	Ultrasound- assisted three phase partitioning	10% (w/v) ammonium sulphate, 1:2 <i>t</i> -butanol: slurry, pH 5 and 5% (w/v) solid loading in the slurry. 40% duty cycle, 36 W of power output and 5 minutes.	64 g/kg of oleoresin yield	Pretreatment with enzymes or ultrasound can greatly improve the recovery of 6-shogaol. The time required for TPP is much less compared to traditional Soxhlet extraction.	(Varakumar et al., 2017)
	Enzyme- assisted three phase partitioning	10% (w/v) ammonium sulphate, 1:2 <i>t</i> -butanol: slurry, pH 5 and 5% (w/v) solid loading in the slurry. 0.5% of accellerase loading.	69 g/kg of oleoresin yield		
Zingibain	Three phase partitioning	50% of (NH <sub>4</sub> ) <sub>2</sub> SO <sub>4</sub> saturation, 1:1 ratio of crude extract and <i>t</i> - butanol; and pH 7	14.91-fold of purification, and 215% recovery	A milk-clotting enzyme was purified from crude ginger extract, obtained from the aqueous phase of a TPP system. This method exhibited high selectivity and purification.	(Gagaoua et al., 2015)



Zingerone 6-gingerol 8-gingerol 10-gingerol 8-shogaol	Ultrasonic-assisted micellar extraction (UAME)	100 mM of hyodeoxycholic acid sodium (biosurfactant), 10 min, and 100 W of ultrasonic power	N/A	MAME extraction proved to be an efficient technique due to its short times and high yields. Biosurfactants facilitate extraction, providing a green alternative against organic solvents.	(Peng et al., 2017)
	Microwave-assisted micellar extraction (MAME)	100 mM of hyodeoxycholic acid sodium (biosurfactant), irradiation time of 10s and 60°C.	88.66% zingerone 90.12% 6-gingerol 93.55% 8-gingerol 97.36% 6-shogaol 90.89% 10-gingerol		
Zingiberene, Geranial, $\beta$ -sesquiphellandrene, Geranyl acetate, Endo-Borneol, etc.	Subcritical water extraction	Hydrothermal extractor. 5000-15000 mL of subcritical water, 10-30 min, 120°C-140°C	2.03 g of bioactive compounds mixture. Variables: 130°C, 37 min, 10 L of subcritical water.	Extraction of bioactive compounds from ginger wastes was achieved with a greener method of extraction.	(Endy Yulianto et al., 2022)
6-gingerol	Sonic assisted water extraction (SAWE)	Mean particle size 0.89-1.77 mm, 45 min, 40 W of applied power, 1:30 sample to solvent ratio (w/v), 45°C, 15% ethanol as entrainer. 28 kHz (low) 800 kHz (high).	38.95 $\pm$ 0.02 % recovery and 16.14 $\pm$ 0.02 mg/g for low frequency. 46.81 $\pm$ 0.49 % recovery and 19.40 $\pm$ 0.49 mg/g for high frequency.	High frequency SAWE achieved recoveries and concentrations 2.69-fold higher than low frequency SAWE. Applied power was statistically proven to be the most significant factor for 6-gingerol extraction.	(Syed Jaapar et al., 2017)
Zingibain	Ultrasound-assisted liquid-liquid microextraction with deep eutectic solvents.	NADES concentration of 25%, source concentration of 15%, 35°C of ultrasound temperature and 10 min. of sonication.	75% of yield and 24- fold of purification	Ultrasound extraction combined with deep eutectic solvents yielded more protease extraction in the NADES enriched top phase.	(Balaraman & Rathnasamy, 2019)



6-gingerol, 8-gingerol, 10-gingerol	High speed counter current chromatography	Two phase solvent system of ether-ethyl-acetate-methanol-water (1:0.2:0.5:0.7 v/v/v/v) and petroleum ether-ethyl-acetate-methanol-water (1:0.2:0.7:0.5 v/v/v/v).	132 mg of 6-gingerol with 98.7% purity, 31 mg of 8-gingerol with 99.3% purity and 61 mg of 10-gingerol with 98.5% purity.	HSCCC was proven to be an efficient method for gingerol purification.	(X. Wang et al., 2011)
6-gingerol, 8-gingerol, 10-gingerol, 6-shogaol	Subcritical water extraction	130°C, 20 bars, 2% ethanol (as co-solvent), particle size 1mm, 0.5 h	16% of bioactives concentration. 1346 µg bioactives/g dried ginger.	Subcritical water extraction coupled with enzymatic pretreatment achieved higher levels of bioactives recovery than subcritical water extraction with sonication pretreatment.	(Nourbakhsh Amiri et al., 2018)
	Ultrasonic-assisted subcritical water extraction	130°C, 20 bars, 2% ethanol (as co-solvent), particle size 1mm, 1 h. Sonication pre-treatment of 50/60 Hz, 280 W and 40°C for 30 min.	16.7% of bioactives concentration. 1393.5 µg bioactives/g dried ginger.		
	Enzyme-assisted subcritical water extraction	130°C, 20 bars, 2% ethanol (as co-solvent), particle size 1mm, 1.5 h. Enzymatic pretreatment: 25 mg α-amylase at 6 U/mg, pH 4.5-5 at 50°C for 30 min.	35.8% of bioactives concentration. 2990.5 µg bioactives/g dried ginger.		
6-gingerol, 6-shogaol	Subcritical water extraction	130°C for 25 min for 6-gingerol. 190°C for 15 min for 6-shogaol.	6-gingerol 0.68 ± 0.08 mg/g and 6-shogaol 0.39 ± 0.03 mg/g.	6-gingerol can suffer from thermal cracking and be transformed into 6-shogaol during subcritical water extraction.	(Ko et al., 2019)

### 345 3.4. Pressurized Liquid Extraction

346 Pressurized liquid extraction (PLE) is a technique that employs solvents at high  
347 temperatures and pressures below their critical points, in which the solvent remains liquid  
348 throughout the extraction process. The result of using these conditions is a change in the  
349 physicochemical properties of the solvent, increasing mass transfer and solubility of the  
350 analytes, while the surface tension and viscosity of the solvent decrease (Carabias-  
351 Martínez et al., 2005). This allows the solvent to flow more easily and deeper into the  
352 matrix that is being extracted. As a result, higher extraction yields are obtained compared  
353 to conventional extractions, while decreasing the solvent consumption. The most  
354 important factors that influence the extraction process in this technique are the  
355 temperature, pressure, matrix, solvent flow rate, and extraction time (Alvarez-Rivera et  
356 al., 2020).

357 In an experiment performed by Hu et al., PLE was employed to obtain 6-, 8-, 10-gingerols,  
358 and 6-shogaol under different operating conditions. The highest total yield was obtained  
359 as high as 346.8 mg/g with an operating time of 20 min and 41 mL of ethanol at 70%.  
360 Additionally, in the experiments, different extraction techniques were carried out and  
361 compared with PFE showing lower yield concentrations (Hu et al., 2011). PLE offered  
362 relative yields of approximately 106.8%, 109.3%, and 108.0% yield for 6-, 8- and 10-  
363 gingerol, respectively.

### 364 3.5. Ultrasonic-assisted extraction



365 Ultrasonic-assisted extraction (UAE) is a technique where ultrasound waves are applied  
366 to the sample in a process called sonication. This process results in cavitation; when the  
367 ultrasound waves create small vacuum bubbles, they implode and create high  
368 temperatures and pressures (4500°C, 5000 MPa) that leads to the disruption of the cells  
369 (Weggler et al., 2020). This technique serves well as a pre-treatment for the extraction of  
370 intracellular products. Some advantages of UAE are the short extraction times, effective  
371 mass transfer, easy scale-up and simplicity. Furthermore, it can be coupled with other  
372 techniques, such as microwave-assisted extraction, enzymes, biosurfactants, solvents,  
373 etc (Yi et al., 2021).

374 Peng and collaborators utilized ultrasonics coupled with micellar extraction, resulting in  
375 the recuperation of 5 different target analytes: Zingerone, 6-gingerol, 8-gingerol, 6-  
376 shogaol and 10-gingerol. For micellar based extractions, surfactants are used to solubilize  
377 solutes in water and facilitate its separation process. In this experiment, hyodeoxycholic  
378 acid sodium was very efficient because the hydroxyl groups in the biosurfactant ring can  
379 form hydrogen and electrostatic interactions with the target molecules and increase mass  
380 transfer. Other parameters tested for an optimal extraction process were sonication time  
381 and ultrasonic power. Moreover, dual and triple frequency ultrasonication can positively  
382 affect the extraction yields of other compounds from ginger. This has the advantage of  
383 uniform energy distribution and ease of resonance within the extract; as well as better  
384 antioxidant and rheological properties (Peng et al., 2017). In the experiments carried out  
385 by Xuhui Chen and coworkers, polysaccharides were obtained from leaves and stems  
386 utilizing double and triple frequency ultrasonics. Yields of  $10.50 \pm 0.2\%$  and  $9.74 \pm 0.3\%$   
387 resulted from this process using triple frequency and double frequency, respectively. The

388 composition of the polysaccharides extracts comprises neutral sugars, uronic acid, sulfate  
389 radicals and monosaccharides (X. Chen et al., 2021).

390 Jan and collaborators utilized ultrasonication to extract polyphenols from freeze dried  
391 samples of ginger and licorice. The extraction efficiency of phenols from the aqueous  
392 phase was estimated as 15.27%. Nonetheless, it was found that ethyl acetate or ethanol  
393 are required to obtain extracts with better antioxidant properties. In this work, several  
394 kinds of phytoconstituents were found in the ginger extract, such as alkaloids, glycosides,  
395 tannins, phenols, flavonoids, proteins and carbohydrates (Jan et al., 2022).

### 396 3.6. Three phase partitioning

397 Three phase partitioning (TPP) is a single-step technique which is mainly used for  
398 protein concentration and purification. It was first described by Denisson and Lovrien, but  
399 it has its precedent in the works of Tan and Lovrien from 1987, who described how  
400 enzyme activity is maintained, and even improved, in alcohol-water mixtures. In principle,  
401 this technique relies on the separation of phases when ammonium sulphate is added to  
402 a mixture of *t*-butanol and water, which would be completely miscible. If there is protein  
403 present in the sample, it will form a third phase between the alcohol and the aqueous  
404 phase (Dennison & Lovrien, 1997). Even though this technique is mainly used for protein  
405 purification, there are several studies that utilize it for other metabolites extraction.  
406 Varakumar and co-workers have used TPP for the recovery of ginger oleoresin by  
407 collecting the *t*-butanol phase and removing the solvent with evaporation under reduced  
408 pressure. They also tested two pre-treatments to the slurry prior to TPP: enzymatic, with  
409 0.5% loading of accellerase; and ultrasonic with 40% duty cycle and 36 W power output.



410 These pre-treatments achieved yields of 69 and 64 g/kg (oleoresin/slurry) with enzyme  
411 and ultrasound, respectively, while significantly improved the concentration of 6-shogaol  
412 from  $1758.6 \pm 124 \mu\text{g/g}$  in TPP to  $2752.3 \pm 102$  and  $2623.4 \pm 128 \mu\text{g/g}$  in enzyme-assisted  
413 TPP and ultrasonic-assisted TPP, respectively. Furthermore, TPP has also been used for  
414 zingibain extraction, a milk-clotting protein present in ginger rhizomes. In this study,  
415 parameters, such as  $(\text{NH}_4)_2\text{SO}_4$  saturation, *t*-butanol concentration, pH, were optimized,  
416 obtaining a purification fold of 14.91, recovery of 215% and milk-clotting activity of 339  
417 U/mL (Varakumar et al., 2017).

### 418 3.7. Novel extraction methods

419 Novel techniques for extraction and purification of metabolites have emerged to achieve  
420 higher yields with less time, power consumption and causing less environmental hazard  
421 (Castro-Muñoz et al., 2016). High Speed Counter Current Chromatography (HSCCC),  
422 Subcritical Water Extraction (SWE), and Magnetic Solid Phase Extraction (MSPE) are  
423 other reported techniques in the last few years that aim to overcome such limitations,  
424 including extraction time, purity, and utilization of hazardous solvents.

#### 425 3.7.1 High speed counter current chromatography

426 High speed counter current chromatography (HSCCC) is a separation technique with a  
427 wide application range, large preparation volumes and flexible operation. It consists of a  
428 two-phase solvent system that establishes a unidirectional hydrodynamic equilibrium in a  
429 high-speed rotating tube. One phase act as a stationary phase while the other acts as a  
430 mobile phase; and then, a large number of stationary phases are retained during elution  
431 (Khan & Liu, 2018). Wang et al. (2021) utilized this chromatographic technique to



432 separate flavonoid compounds from the remaining ginger powder of a ginger oil extraction  
433 process. Five fractions of flavonoids were obtained utilizing n-hexane-ethyl-acetate-  
434 methanol-water (4:5:4:5 v/v/v/v) and n-hexane-ethyl-acetate-methanol-water (1:5:1:5  
435 v/v/v/v) as the two solvent phases. This led to the extraction of rutin (16.6%), tangeretin  
436 (13.1%), vitexin (18.37%) myricetin-3-O-glucopyranoside (3.3%) and isoquercitrin  
437 (15.2%). Gingerol has also been purified in the works of Wang et al. (2011), where they  
438 utilized petroleum ether-ethyl-acetate-methanol-water (1:0.2:0.5:0.7 v/v/v/v) and  
439 petroleum ether-ethyl-acetate-methanol-water (1:0.2:0.7:0.5 v/v/v/v) as the two-solvent  
440 system; obtaining purities of 6-gingerol, 8-gingerol and 10-gingerol higher than 98%.  
441 From 360 mg of the pre-purified sample, 132 mg of 6-gingerol, 31 mg of 8-gingerol and  
442 61 mg of 10-gingerol were obtained. The utilization of HSCCC permits a process without  
443 irretrievable sample adsorption; that is why it can separate high amounts of the desired  
444 analytes (X. Chen et al., 2021).

#### 445 3.7.2 Subcritical water extraction

446 Subcritical water extraction (SWE) allows the recovery of less-polar compounds. In this  
447 technique, water is maintained in a liquid state under high pressures and high  
448 temperatures ranging from 100 to 374°C. The extraction times are as short as 30 min;  
449 and the dielectric constant of the water is lower, weakening the hydrogen bonds and  
450 changing the polarity of water (Ko et al., 2020). At subcritical conditions, the viscosity and  
451 surface tension of water decreases, promoting the mass transfer rate and adsorption into  
452 the particle-matrix that is being worked on. Another advantage of this technique is the  
453 zero toxicity that water represents to the final product. Endy Yulianto et al. studied this  
454 technique for the recovery of bioactive compounds from ginger dregs, utilizing statistical

455 methods for optimization. The optimal conditions were determined as 120°C, 10 L of  
456 solvent (water) and 30 min. Among the isolated compounds, it was found zingiberene,  
457 geranial,  $\beta$ -sesquiphellandrene, geranyl acetate, endo-borneol, etc (Endy Yulianto et al.,  
458 2022).

459 Amiri et al. (2018) utilized subcritical water extraction as well to purify bioactive  
460 compounds from dried ginger. Apart from the SWE, they compared sonication and  
461 enzymatic pre-treatment. For the SWE, optimal conditions were studied, obtaining 130°C,  
462 20 bars, 2% ethanol (as co-solvent), particle size 1mm, 0.5 h. Between the two pre-  
463 treatments, enzymatic pre-treatment turned out to have higher extraction efficiency than  
464 sonication and SWE alone. While SWE and -ultrasonication-assisted SWE reached 16%  
465 and 16.7%, respectively, during the recovery of bioactive. In comparison to traditional  
466 Soxhlet extraction, Enzymatic-SWE reached higher recovery of ca. 35.8%. This means  
467 that more than double extraction efficiency can be achieved by using enzymes.  $\alpha$ -amylase  
468 is an enzyme that disrupts the cell wall; hence, its utilization coupled with the particle size  
469 of dried ginger utilized, helped to release a great number of intracellular products  
470 (Nourbakhsh Amiri et al., 2018).

### 471 3.7.3 Magnetic solid phase extraction

472 Magnetic solid phase extraction (MSPE) is a new technique that utilizes a magnetic  
473 adsorbent to a solution containing a certain analyte. The analyte is adsorbed into the  
474 magnetic sorbent and then separated magnetically. Finally, the analyte eluted from the  
475 recovered adsorbent. This procedure has been used for the isolation and  
476 preconcentration of specific analytes surpassing the long times of conventional solid-



477 phase and liquid-phase extractions (Šafaříková & Šafařík, 1999). To the best of our  
 478 knowledge, the pioneering work documented by Akamine et al. (2021) is the only  
 479 experimental attempt where a magnetic nanocomposite has been used as a sorbent for  
 480 the extraction of GNs, as graphically represented in **Figure 6**. Herein, a magnetic  
 481 nanocomposite GO-Fe<sub>3</sub>O<sub>4</sub> was employed for the analysis of GNs in different food  
 482 samples. The highest yields were 6-gingerol: 4.0 µg/mg from ginger extract, 8-gingerol:  
 483 0.64 µg/mg from tea leaves, 10-gingerol: 0.46 µg/mg from tea leaves (Akamine et al.,  
 484 2021).

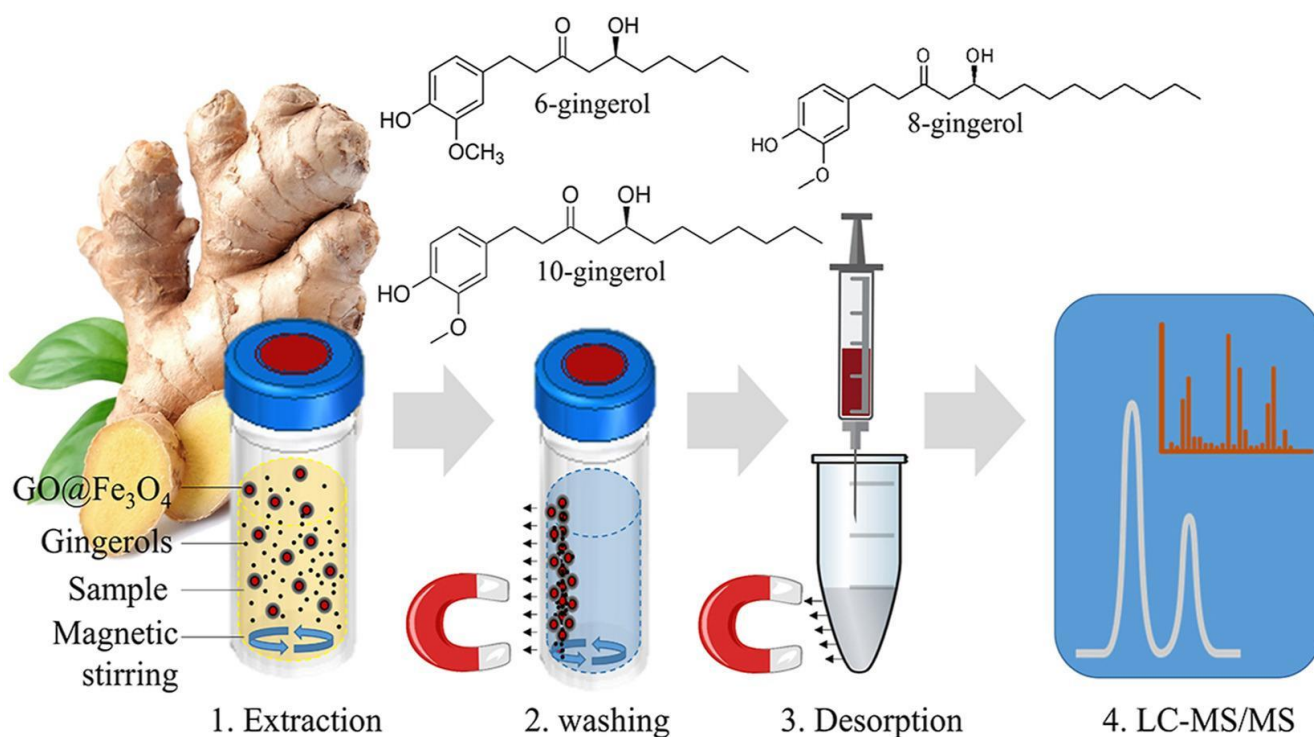

**Figure 6.** Magnetic Solid Phase Extraction of gingerols using a GO-Fe<sub>3</sub>O<sub>4</sub> nanocomposite (Akamine et al., 2021).



## 490 **6. Concluding remarks and perspectives**

491 Ginger biomolecules have proven to show interesting medicinal properties, such as  
492 anti-inflammatory, anti-cancerous, anti-oxidative, anti-microbial activities as well as  
493 reducing oxidative parameters. Thanks to research community, *gingerols*, *shogaols* and  
494 *zingerone* have been identified and recognized as the main bioactive substances  
495 contained in Ginger extracts, which could potentially be used in new food and  
496 pharmaceutical formulations; unfortunately, the extraction and purification of such  
497 bioactive still remains as a challenge since there is still no artificial pathway for producing  
498 them; therefore, extraction and purification processes seem to be the most friendly and  
499 efficient way to obtaining them from their natural source. In this review, we declare the  
500 efforts of the research community on extracting ginger biomolecules (mainly gingerols),  
501 in which solvent extraction has been observed as the pioneering technique in this task.  
502 Even if solvent extraction is seen as a classic separation method, the advent of  
503 developing new solvents, such as ionic liquid and deep eutectic solvents, still makes it  
504 functional and versatile as starting point of extraction. This latter statement is supported  
505 by the current need of producing more healthy food enriched with nutraceutical  
506 substances to alleviate symptoms of endemic and unprecedented epidemics (e.g.,  
507 coronavirus).

508 In addition to solvent extraction, other techniques, such MAE, PLE, supercritical fluid  
509 extraction, UAE, have revealed interesting outcomes and great advantages. Specially,  
510 emerging techniques, such as UAE, have confirmed to be highly selective when dealing  
511 with the extraction of specific target molecules, e.g., it has shown exceptional recovery  
512 (over 90%) toward zingerone, 6-gingerol, 8-gingerol and 10-gingerol, while an almost



513 complete recovery (ca. 97.36%) of 6-shogaol has been also observed. In the coming  
514 future, it is likely that novel and emerging techniques will be evaluated for their ability in  
515 recovering such compounds.

516

## 517 **Acknowledgments**

518 Financial support from Nobelium Joining Gdańsk Tech Research Community (contract  
519 number DEC 33/2022/IDUB/I.1; NOBELIUM nr 036236) is gratefully acknowledged. R.  
520 Castro-Muñoz also acknowledges the School of Engineering and Science and the  
521 FEMSA-Biotechnology Center at Tecnológico de Monterrey for their support through the  
522 Bioprocess (0020209113) Focus Group.

523

## 524 **Conflict of Interest**

525 The authors declare no conflict of interest.

526

## 527 **References**

528 Ahmad, B., Rehman, M. U., Amin, I., Arif, A., Rasool, S., Bhat, S. A., Afzal, I., Hussain, I., Bilal,  
529 S., Ur, M. & Mir, R. (2015). *A Review on Pharmacological Properties of Zingerone (4-(4-*  
530 *Hydroxy-3-methoxyphenyl)-2-butanone)*. <https://doi.org/10.1155/2015/816364>

531 Akamine, L. A., Vargas Medina, D. A. & Lanças, F. M. (2021). Magnetic solid-phase extraction  
532 of gingerols in ginger containing products. *Talanta*, 222, 121683.  
533 <https://doi.org/10.1016/J.TALANTA.2020.121683>

534 Alvarez-Rivera, G., Bueno, M., Ballesteros-Vivas, D., Mendiola, J. A. & Ibañez, E. (2020).  
535 Pressurized Liquid Extraction. *Liquid-Phase Extraction*, 375–398.  
536 <https://doi.org/10.1016/B978-0-12-816911-7.00013-X>

537 Anh, N. H., Kim, S. J., Long, N. P., Min, J. E., Yoon, Y. C., Lee, E. G., Kim, M., Kim, T. J., Yang,  
538 Y. Y., Son, E. Y., Yoon, S. J., Diem, N. C., Kim, H. M. & Kwon, S. W. (2020). Ginger on  
539 Human Health: A Comprehensive Systematic Review of 109 Randomized Controlled  
540 Trials. *Nutrients*, 12(1). <https://doi.org/10.3390/NU12010157>



- 541 Balaraman, H. B. & Rathnasamy, S. K. (2019). Selective purification of protease from ginger  
542 and sodom apple by ultrasound assisted liquid-liquid microextraction using natural deep  
543 eutectic solvent. *Microchemical Journal*, 150, 104132.  
544 <https://doi.org/10.1016/J.MICROC.2019.104132>
- 545 Bellik, Y. (2014). Total antioxidant activity and antimicrobial potency of the essential oil and  
546 oleoresin of *Zingiber officinale* Roscoe. *Asian Pacific Journal of Tropical Disease*, 4(1), 40.  
547 [https://doi.org/10.1016/S2222-1808\(14\)60311-X](https://doi.org/10.1016/S2222-1808(14)60311-X)
- 548 Bener, M., Şen, F. B., Önem, A. N., Bekdeşer, B., Çelik, S. E., Lalikoglu, M., Aşçı, Y. S.,  
549 Capanoglu, E. & Apak, R. (2022). Microwave-assisted extraction of antioxidant compounds  
550 from by-products of Turkish hazelnut (*Corylus avellana* L.) using natural deep eutectic  
551 solvents: Modeling, optimization and phenolic characterization. *Food Chemistry*, 385,  
552 132633. <https://doi.org/10.1016/J.FOODCHEM.2022.132633>
- 553 Carabias-Martínez, R., Rodríguez-Gonzalo, E., Revilla-Ruiz, P. & Hernández-Méndez, J.  
554 (2005). Pressurized liquid extraction in the analysis of food and biological samples. *Journal*  
555 *of Chromatography A*, 1089(1–2), 1–17. <https://doi.org/10.1016/J.CHROMA.2005.06.072>
- 556 Castro-Muñoz, R., Díaz-Montes, E., Gontarek-Castro, E., Boczkaj, G. & Galanakis, C. M.  
557 (2022). A comprehensive review on current and emerging technologies toward the  
558 valorization of bio-based wastes and by products from foods. *Comprehensive Reviews in*  
559 *Food Science and Food Safety*, 21(1), 46–105. <https://doi.org/10.1111/1541-4337.12894>
- 560 Castro-Muñoz, R., Gontarek-Castro, E. & Jafari, S. M. (2022). Up-to-date strategies and future  
561 trends towards the extraction and purification of Capsaicin: A comprehensive review.  
562 *Trends in Food Science & Technology*, 123, 161–171.  
563 <https://doi.org/10.1016/J.TIFS.2022.03.014>
- 564 Castro-Muñoz, R., Yáñez-Fernández, J. & Fíla, V. (2016). Phenolic compounds recovered from  
565 agro-food by-products using membrane technologies: An overview. *Food Chemistry*, 213,  
566 753–762. <https://doi.org/10.1016/J.FOODCHEM.2016.07.030>
- 567 Chen, H. & Wang, L. (2017). Posttreatment Strategies for Biomass Conversion. *Technologies*  
568 *for Biochemical Conversion of Biomass*, 197–217. <https://doi.org/10.1016/B978-0-12-802417-1.00008-9>
- 570 Chen, X., Wang, Z. & Kan, J. (2021). Polysaccharides from ginger stems and leaves: Effects of  
571 dual and triple frequency ultrasound assisted extraction on structural characteristics and  
572 biological activities. *Food Bioscience*, 42, 101166.  
573 <https://doi.org/10.1016/J.FBIO.2021.101166>
- 574 Danwilai, K., Konmun, J., Sripanidkulchai, B. O. & Subongkot, S. (2017). Antioxidant activity of  
575 ginger extract as a daily supplement in cancer patients receiving adjuvant chemotherapy: a  
576 pilot study. *Cancer Management and Research*, 9, 11.  
577 <https://doi.org/10.2147/CMAR.S124016>

- 578 Dennison, C. & Lovrien, R. (1997). Three Phase Partitioning: Concentration and Purification of  
579 Proteins. In *PROTEIN EXPRESSION AND PURIFICATION* (Vol. 11).
- 580 Elseweidy, M. M., Abdallah, F. R., Younis, N. N., Aldohmy, S. & Kassem, H. M. (2013). 10-  
581 Dehydrogingerdione raises HDL-cholesterol through a CETP inhibition and wards off  
582 oxidation and inflammation in dyslipidemic rabbits. *Atherosclerosis*, 231(2), 334–340.  
583 <https://doi.org/10.1016/J.ATHEROSCLEROSIS.2013.09.024>
- 584 Endy Yulianto, M., Paramita, V., Amalia, R., Wahyuningsih, N. & Dwi Nyamiati, R. (2022).  
585 Production of bioactive compounds from ginger (*Zingiber officinale*) dregs through  
586 subcritical water extraction. *Materials Today: Proceedings*, 63, S188–S194.  
587 <https://doi.org/10.1016/J.MATPR.2022.02.216>
- 588 Fischer-Rasmussen, W., Kjær, S. K., Dahl, C. & Asping, U. (1991). Ginger treatment of  
589 hyperemesis gravidarum. *European Journal of Obstetrics, Gynecology, and Reproductive*  
590 *Biology*, 38(1), 19–24. [https://doi.org/10.1016/0028-2243\(91\)90202-V](https://doi.org/10.1016/0028-2243(91)90202-V)
- 591 Gagaoua, M., Hoggas, N. & Hafid, K. (2015). Three phase partitioning of zingibain, a milk-  
592 clotting enzyme from *Zingiber officinale* Roscoe rhizomes. *International Journal of*  
593 *Biological Macromolecules*, 73(1), 245–252.  
594 <https://doi.org/10.1016/J.IJBIOMAC.2014.10.069>
- 595 Guo, J. B., Fan, Y., Zhang, W. J., Wu, H., Du, L. M. & Chang, Y. X. (2017). Extraction of  
596 gingerols and shogaols from ginger (*Zingiber officinale* Roscoe) through microwave  
597 technique using ionic liquids. *Journal of Food Composition and Analysis*, 62, 35–42.  
598 <https://doi.org/10.1016/J.JFCA.2017.04.014>
- 599 Hu, J., Guo, Z., Glasius, M., Kristensen, K., Xiao, L. & Xu, X. (2011). Pressurized liquid  
600 extraction of ginger (*Zingiber officinale* Roscoe) with bioethanol: An efficient and  
601 sustainable approach. *Journal of Chromatography A*, 1218(34), 5765–5773.  
602 <https://doi.org/10.1016/J.CHROMA.2011.06.088>
- 603 Jan, R., Gani, A., Masarat Dar, M. & Bhat, N. A. (2022). Bioactive characterization of  
604 ultrasonicated ginger (*Zingiber officinale*) and licorice (*Glycyrrhiza Glabra*) freeze dried  
605 extracts. *Ultrasonics Sonochemistry*, 88, 106048.  
606 <https://doi.org/10.1016/J.ULTSONCH.2022.106048>
- 607 Juin, C., Chérouvrier, J. R., Thiéry, V., Gagez, A. L., Bérard, J. B., Joguet, N., Kaas, R.,  
608 Cadoret, J. P. & Picot, L. (2015). Microwave-assisted extraction of phycobiliproteins from  
609 porphyridium purpureum. *Applied Biochemistry and Biotechnology*, 175(1), 1–15.  
610 <https://doi.org/10.1007/S12010-014-1250-2/FIGURES/7>
- 611 Keosaeng, K., Songoen, W., Yooboon, T., Bullangpoti, V. & Pluempanupat, W. (2022).  
612 Insecticidal activity of isolated gingerols and shogaols from *Zingiber officinale* Roscoe  
613 rhizomes against *Spodoptera* spp. (Lepidoptera: Noctuidae).  
614 <https://doi.org/10.1080/14786419.2022.2078818>  
615 <https://doi.org/10.1080/14786419.2022.2078818>



- 616 Khan, B. M. & Liu, Y. (2018). High speed counter current chromatography: Overview of solvent-  
617 system and elution-mode. <https://doi.org/10.1080/10826076.2018.1499528>, 41(10), 629–  
618 636. <https://doi.org/10.1080/10826076.2018.1499528>
- 619 Ko, M. J., Nam, H. H. & Chung, M. S. (2019). Conversion of 6-gingerol to 6-shogaol in ginger  
620 (Zingiber officinale) pulp and peel during subcritical water extraction. *Food Chemistry*, 270,  
621 149–155. <https://doi.org/10.1016/J.FOODCHEM.2018.07.078>
- 622 Ko, M. J., Nam, H. H. & Chung, M. S. (2020). Subcritical water extraction of bioactive  
623 compounds from *Orostachys japonicus* A. Berger (Crassulaceae). *Scientific Reports 2020*  
624 10:1, 10(1), 1–10. <https://doi.org/10.1038/s41598-020-67508-2>
- 625 Kumar, S., Saxena, K., Uday, I., Singh, N., Saxena, R. & Singh, U. N. (2013). Anti-inflammatory  
626 action of ginger: A critical review in anemia of inflammation and its future aspects During  
627 Corona Pandemic I have started Online Teaching View project MEDICAL EDUCATION  
628 UNIT : APPLICATION AND FUTURE ROAD MAP View project Anti-inflammatory action of  
629 ginger: A critical review in anemia of inflammation and its future aspects. *International*  
630 *Journal of Herbal Medicine*, 1(4), 16–20.  
631 <https://www.researchgate.net/publication/334107433>
- 632 Lee, H. Y., Park, S. H., Lee, M., Kim, H. J., Ryu, S. Y., Kim, N. D., Hwang, B. Y., Hong, J. T.,  
633 Han, S. B. & Kim, Y. (2012). 1-Dehydro-[10]-gingerdione from ginger inhibits IKK $\beta$  activity  
634 for NF- $\kappa$ B activation and suppresses NF- $\kappa$ B-regulated expression of inflammatory genes.  
635 *British Journal of Pharmacology*, 167(1), 128. [https://doi.org/10.1111/J.1476-  
636 5381.2012.01980.X](https://doi.org/10.1111/J.1476-5381.2012.01980.X)
- 637 Li, F., Wang, Y., Parkin, K. L., Nitteranon, V., Liang, J., Yang, W., Li, Y., Zhang, G. & Hu, Q.  
638 (2011). Isolation of quinone reductase (QR) inducing agents from ginger rhizome and their  
639 in vitro anti-inflammatory activity. *Food Research International*, 44(6), 1597–1603.  
640 <https://doi.org/10.1016/J.FOODRES.2011.04.010>
- 641 Liu, W., Zhou, C. L., Zhao, J., Chen, D. & Li, Q. H. (2014). Optimized microwave-assisted  
642 extraction of 6-gingerol from *Zingiber officinale* Roscoe and evaluation of antioxidant activity  
643 in vitro. *Acta Scientiarum Polonorum. Technologia Alimentaria*, 13(2), 155–168.  
644 <https://doi.org/10.17306/J.AFS.2014.2.5>
- 645 López Flores, A. R. C., Luna-Urban, C., Buenrostro-Figueroa J.J., Hernández-Martínez, R.,  
646 Huerta-Ochoa, S., Escalona-Buendía, H., Aguilar-González, C. N. & Prado-Barragán, L. A.  
647 (2016). *Revista Mexicana de Ingeniería Química CONTENIDO*. [www.rmiq.org](http://www.rmiq.org)
- 648 Mao, Q. Q., Xu, X. Y., Cao, S. Y., Gan, R. Y., Corke, H., Beta, T. & Li, H. bin. (2019). Bioactive  
649 Compounds and Bioactivities of Ginger (*Zingiber officinale* Roscoe). *Foods*, 8(6).  
650 <https://doi.org/10.3390/FOODS8060185>
- 651 Menon, V., Elgharib, M., El-awady, R. & Saleh, E. (2021). Ginger: From serving table to salient  
652 therapy. *Food Bioscience*, 41, 100934. <https://doi.org/10.1016/J.FBIO.2021.100934>



- 653 Mesomo, M. C., Scheer, A. D. P., Perez, E., Ndiaye, P. M. & Corazza, M. L. (2012). Ginger  
654 (Zingiber officinale R.) extracts obtained using supercritical CO<sub>2</sub> and compressed propane:  
655 Kinetics and antioxidant activity evaluation. *The Journal of Supercritical Fluids*, 71, 102–  
656 109. <https://doi.org/10.1016/J.SUPFLU.2012.08.001>
- 657 Nourbakhsh Amiri, Z., Najafpour, G. D., Mohammadi, M. & Moghadamnia, A. A. (2018).  
658 Subcritical Water Extraction of Bioactive Compounds from Ginger (Zingiber officinale  
659 Roscoe). *International Journal of Engineering*, 31(12), 1991–2000.  
660 <https://doi.org/10.5829/ije.2018.31.12c.01>
- 661 Park, Y. J., Wen, J., Bang, S., Park, S. W. & Song, S. Y. (2006). [6]-Gingerol induces cell cycle  
662 arrest and cell death of mutant p53-expressing pancreatic cancer cells. *Yonsei Medical*  
663 *Journal*, 47(5), 688–697. <https://doi.org/10.3349/YMJ.2006.47.5.688>
- 664 Peng, L. Q., Cao, J., Du, L. J., Zhang, Q. D., Xu, J. J., Chen, Y. B., Shi, Y. T. & Li, R. R. (2017).  
665 Rapid ultrasonic and microwave-assisted micellar extraction of zingiberone, shogaol and  
666 gingerols from gingers using biosurfactants. *Journal of Chromatography A*, 1515, 37–44.  
667 <https://doi.org/10.1016/J.CHROMA.2017.07.092>
- 668 Rahmani, A. H., al Shabrimi, F. M. & Aly, S. M. (2014). Active ingredients of ginger as potential  
669 candidates in the prevention and treatment of diseases via modulation of biological  
670 activities. *International Journal of Physiology, Pathophysiology and Pharmacology*, 6(2),  
671 125. /pmc/articles/PMC4106649/
- 672 Routray, W. & Orsat, V. (2019). Microwave Assisted Extraction of Flavonoids: A Comprehensive  
673 Overview. In *Reference Module in Food Science*. Elsevier. <https://doi.org/10.1016/B978-0-08-100596-5.21108-6>
- 675 Rupasinghe, V. & Gunathilake, K. (2015). Recent perspectives on the medicinal potential of  
676 ginger. *Botanics: Targets and Therapy*, 55. <https://doi.org/10.2147/btat.s68099>
- 677 Sabina, E. P., Pragasam, S. J., Kumar, S. & Rasool, M. (2011). 6-gingerol, an active ingredient  
678 of ginger, protects acetaminophen-induced hepatotoxicity in mice. *Zhong Xi Yi Jie He Xue*  
679 *Bao = Journal of Chinese Integrative Medicine*, 9(11), 1264–1269.  
680 <https://doi.org/10.3736/JCIM20111116>
- 681 Šafaříková, M. & Šafařík, I. (1999). Magnetic solid-phase extraction. *Journal of Magnetism and*  
682 *Magnetic Materials*, 194(1–3), 108–112. [https://doi.org/10.1016/S0304-8853\(98\)00566-6](https://doi.org/10.1016/S0304-8853(98)00566-6)
- 683 Said, P. P., Arya, O. P., Pradhan, R. C., Singh, R. S. & Rai, B. N. (2015). Separation of  
684 Oleoresin from Ginger Rhizome Powder Using Green Processing Technologies. *Journal of*  
685 *Food Process Engineering*, 38(2), 107–114. <https://doi.org/10.1111/JFPE.12127>
- 686 Salea, R., Veriansyah, B. & Tjandrawinata, R. R. (2017). Optimization and scale-up process for  
687 supercritical fluids extraction of ginger oil from Zingiber officinale var. Amarum. *The Journal*  
688 *of Supercritical Fluids*, 120, 285–294. <https://doi.org/10.1016/J.SUPFLU.2016.05.035>





- 689 Schadich, E., Hlaváč, J., Volná, T., Varanasi, L., Hajdúch, M. & Džubák, P. (2016). Effects of  
690 Ginger Phenylpropanoids and Quercetin on Nrf2-ARE Pathway in Human BJ Fibroblasts  
691 and HaCaT Keratinocytes. *BioMed Research International*, 2016.  
692 <https://doi.org/10.1155/2016/2173275>
- 693 Semwal, R. B., Semwal, D. K., Combrinck, S. & Viljoen, A. M. (2015). Gingerols and shogaols:  
694 Important nutraceutical principles from ginger. *Phytochemistry*, 117, 554–568.  
695 <https://doi.org/10.1016/J.PHYTOCHEM.2015.07.012>
- 696 Shukla, A., Naik, S. N., Goud, V. v. & Das, C. (2019). Supercritical CO<sub>2</sub> extraction and online  
697 fractionation of dry ginger for production of high-quality volatile oil and gingerols enriched  
698 oleoresin. *Industrial Crops and Products*, 130, 352–362.  
699 <https://doi.org/10.1016/j.indcrop.2019.01.005>
- 700 Swapna Sonale, R. & Kadimi, U. S. (2014). Characterization of gingerol analogues in  
701 supercritical carbon dioxide (SC CO<sub>2</sub>) extract of ginger (*Zingiber officinale*, R.). *Journal of*  
702 *Food Science and Technology*, 51(11), 3383. <https://doi.org/10.1007/S13197-012-0851-4>
- 703 Syed Jaapar, S. Z., Morad, N. A., Iwai, Y. & Nordin, M. F. M. (2017). Effects of processing  
704 parameters in the sonic assisted water extraction (SAWE) of 6-gingerol. *Ultrasonics*  
705 *Sonochemistry*, 38, 62–74. <https://doi.org/10.1016/j.ultsonch.2017.02.034>
- 706 Teng, H., Seuseu, K. T., Lee, W. Y. & Chen, L. (2019). Comparing the effects of microwave  
707 radiation on 6-gingerol and 6-shogaol from ginger rhizomes (*Zingiber officinale* Rosc).  
708 *PLOS ONE*, 14(6), e0214893. <https://doi.org/10.1371/JOURNAL.PONE.0214893>
- 709 Varakumar, S., Umesh, K. V. & Singhal, R. S. (2017). Enhanced extraction of oleoresin from  
710 ginger (*Zingiber officinale*) rhizome powder using enzyme-assisted three phase  
711 partitioning. *Food Chemistry*, 216, 27–36.  
712 <https://doi.org/10.1016/J.FOODCHEM.2016.07.180>
- 713 Wang, L. xia, Hu, C., Zhang, J. di, Gong, P. sen, Zhang, H. & Zhao, S. hua. (2022).  
714 Identification of Five Flavonoid Compounds from the Remaining Ginger Powder Purified by  
715 Using High-Speed Counter-Current Chromatography and Their Bioactivity. *Food Analytical*  
716 *Methods*, 15(2), 485–497. <https://doi.org/10.1007/S12161-021-02103-3/FIGURES/5>
- 717 Wang, X., Zheng, Z., Guo, X., Yuan, J. & Zheng, C. (2011). Preparative separation of gingerols  
718 from *Zingiber officinale* by high-speed counter-current chromatography using stepwise  
719 elution. *Food Chemistry*, 125(4), 1476–1480.  
720 <https://doi.org/10.1016/J.FOODCHEM.2010.10.066>
- 721 Weggler, B. A., Gruber, B., Teehan, P., Jaramillo, R. & Dorman, F. L. (2020). Inlets and  
722 sampling. *Separation Science and Technology (New York)*, 12, 141–203.  
723 <https://doi.org/10.1016/B978-0-12-813745-1.00005-2>
- 724 Yi, Z., Su, Y., Brynjolfsson, S., Olafsdóttir, K. & Fu, W. (2021). Bioactive polysaccharides and  
725 their derivatives from microalgae: biosynthesis, applications, and challenges. *Studies in*



726 *Natural Products Chemistry*, 71, 67–85. [https://doi.org/10.1016/B978-0-323-91095-](https://doi.org/10.1016/B978-0-323-91095-8.00007-6)  
727 8.00007-6

728 Yulianto, M. E., Amalia, R., Paramita, V., Hartati, I. & Nisa, Q. A. K. (2020). Mass Transfer  
729 Coefficient Study of Shogaol Extraction in Ginger Using Subcritical Water. *IOP Conference*  
730 *Series: Materials Science and Engineering*, 771(1). [https://doi.org/10.1088/1757-](https://doi.org/10.1088/1757-899X/771/1/012039)  
731 899X/771/1/012039

732 Zhang, M., Viennois, E., Prasad, M., Zhang, Y., Wang, L., Zhang, Z., Han, M. K., Xiao, B., Xu,  
733 C., Srinivasan, S. & Merlin, D. (2016). *Edible ginger-derived nanoparticles: A novel*  
734 *therapeutic approach for the prevention and treatment of inflammatory bowel disease and*  
735 *colitis-associated cancer*. <https://doi.org/10.1016/j.biomaterials.2016.06.018>

736

737

738

739

740

741

742

743

744

745