

A device for measuring heat flux on a rocket skin surface

Adam Dąbrowski^{a*}, Róża Pietruszewska^b, Szymon Krawczuk^c

^a *Institute of Mechatronics and Machine Construction, Faculty of Mechanical Engineering and Ship Technology, Gdańsk University of Technology, ul Gabriela Narutowicza 11/12 80-233 Gdańsk, Poland adadabro@pg.edu.pl*

^b *WSB University, Aleja Grunwaldzka 238A, 80-266 Gdańsk, mateusz.zgirski@gmail.com*

^c *Faculty of Mechanical Engineering and Ship Technology, Gdańsk University of Technology, ul Gabriela Narutowicza 11/12 80-233 Gdańsk, Poland szymon.r.krawczuk@gmail.com*

* Corresponding Author

Abstract

A novel method for measuring heat flux on a surface is presented. It is an extensive upgrade of currently known heat flux sensors used mostly in civil engineering. As the thermal environment of launchers, especially sounding rocket can have an enormous negative effect on payload, careful considerations have to be taken in the process of preparing insulation. These problems are handled in the design of new heat flux sensor. Due to special design, a 1D homogenous heat flow is enforced which allows easy model estimation and simplifies future calculations.

As a result, no complicated finite element analysis is required and apparent heat flux density values can be calculated in real time by a simple embedded system with little computation power. A crucial element is dimensioning the sensor to match the launcher. The most important criteria are proper range of measurement (no saturation) and appropriate sensitivity. The physics of the sensor has been carefully examined by various means including: analytical calculations, finite differences model and finite element analysis. The results of these calculations are verified with flights on sounding rockets. The device has a commercialization purpose for any launcher. The data it provides enables for more precise design of future payload, such as insulation thickness optimisation or material choice. Preliminary results from sounding rocket flights will be presented.

Keywords: heat transfer, heat flux, thermal engineering, sensors, measurement

Nomenclature

- L1 – necking length (see Fig. 3),
- L2 – container length (see Fig. 3),
- R – thermal resistance
- k – coefficient of thermal conductivity
- ΔT – temperature difference

Acronyms/Abbreviations

Direct Current to Direct Current DCDC
European Consortium for Space Standardisation ECSS
High quality Experiment Dedicated to microGravity Exploration, Heat flow and Oscillations from Gdańsk HEDGEHOG
Inverse Heat Transfer Problem IHTP
Finite Element Method FEM
Printed Circuit Board PCB
Rocket EXperiments for University Students REXUS

1. Introduction

Usually, thermal data provided by the launch vehicle manufacturer is limited only to temperature ranges, sometimes time plot. However, temperature is a very local phenomenon, and depends heavily on multiple factors such as launch configuration, insulation material, convection coefficient, air pressure, etc. Technical standards such as ECSS-E-HB-31-03A [1] – Thermal analysis handbook encourages to perform thermal

Coupled Launch Analysis [2] prior to launch. Access to precise boundary conditions is limiting verification of such results. The heat flux density on rocket skin varies greatly during course of flight, as the vehicle traverses layers of atmosphere of various density with various velocities. Furthermore, it is difficult to determine the vector of heat flow a priori.

2. Device background

The device for measuring heat flux on a rocket skin surface is a novel device patented by Gdańsk University of Technology [3]. It has been designed for HEDGEHOG REXUS Project [4] – a scientific experiment on REXUS sounding rocket. The usual approach of thermal analysis in case of REXUS experiments is to use previous flight temperature profiles for detailed temperature information [REXUS manual]. While this is a good solution as a first guess, the temperature depends on both the actual heat flux density on the rocket skin surface (due to high velocity flight through thick layers of atmosphere) and the configuration of the experiment. The temperature varies vastly by more than 30 degrees depending on experiment and factors such as proximity to wall and material (different heat conduction coefficients).

The HEDGEHOG team proposed to measure the heat flux itself by measuring temperature in different points of a well-defined, easy, axial-symmetric geometry. After the flight, an inverse heat transfer problem (IHTP) was solved using methodology presented in [5].

Such approach has been tested on data kindly provided SMARD team, described in [6]. Although their temperature measurement was only an addition to their main functionality, using their data HEDGEHOG science was able to obtain a rough estimate on heat flux.

This experience allowed us to dimension the experiment properly. With data about a sample heat flux variation during the flight, a further group, given the geometry of an experiment, can perform numerical analysis solving forward heat transfer problem and thus obtaining a very good estimation of temperatures in any point of their experiment. This allows for optimising, such as increasing insulation, changing material or modifying configuration of the payload.

3. Device design

The method of measuring the variability of the heat flux from the tested surface, especially the shell of a space rocket, consisting in measuring the differences in heat flux with the use of thermoelectric sensors is characterized by the fact that the heat flux from the tested surface is collected by means of a heat accumulating element, which is made of essentially the same material, in terms of thermomechanical properties, as the test surface, and its outer side circumferentially conforms to the shape of the inner side of the tested surface, preferably in the form of a ring. In the heat accumulating element, a narrow is formed halfway its width, at both ends of which, between the heat conductor formed in this way on the side of the tested surface and the heat reservoir, the heat fluxes are measured in a known manner by means of perpendicular to the flow vector mounted to a depth substantially equal to half the throat height of the two thermocouples. The heat-storing element is attached internally to the test surface, and a heat-conducting paste is applied to the contact point of the heat-accumulating element and the test surface.

The heat-storing element is preferably covered with a layer of insulation. The design enforces a homogeneous heat flow, which means developing a simple, one-dimensional heat flow model, ideal for identification. Due to the arrangement of thermocouples perpendicular to the line of the heat flow vector, the smallest possible impact on the heat flow itself is obtained. The large internal mass acts as a heat reservoir, which allows you to store a sufficiently large thermal energy. Due to the fact that the heat reservoir absorbs heat for a long time, a temperature difference is ensured between the two

ends of the constriction, which increases the accuracy of the heat flow measurement.

By using the method of measuring the heat flux, the value of the heat source power, which is otherwise difficult to access, is obtained – the aerodynamic resistance to the outside of the package. The measured value makes it possible to simulate or recreate the thermal environment of the rocket under controlled conditions. This makes it possible to test the behavior and durability of experiments that are planned to be launched into space with a given rocket. In this way, you can also design the experiment itself to be able to withstand rocket flight.

The device is shown schematically in Fig. 1 (without insulation) and Fig. 2. (with insulation).

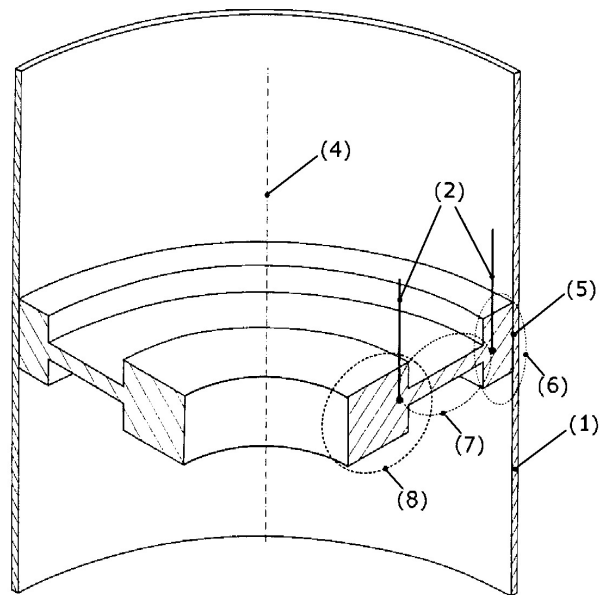

Fig. 1. Cross section of the device [3].

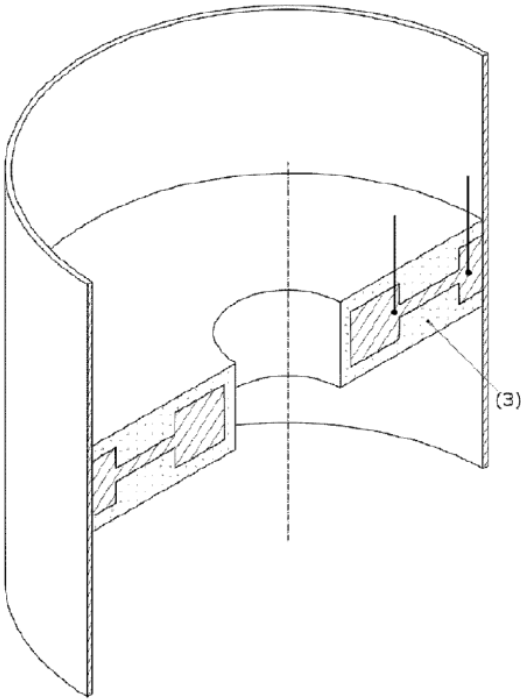

Fig. 2. Device with insulation [3].

According to the numbering in Fig 1., the device works as follows. A thick ring is made of a material with thermomechanical properties similar to the material of which the rocket shell (1) is made, and a thick ring is made, which is attached circumferentially to the inside of the rocket shell (1). A thermally conductive paste is applied at the contact point (5). The ring is made of a narrowing (7) forcing a one-dimensional flow heat, having a low heat capacity, separating the heat conductor (6) from the heat reservoir (8). The heat reservoir (8) allows a large heat flux to be absorbed for a longer time, providing a temperature difference at the two ends of the necking (7). The axis of symmetry of the ring is in line with the axis rockets (4), thanks to which it is possible to use an axisymmetric model of heat flow. At both ends of the throat (1), two thermocouples (2) are attached, arranged perpendicular to the direction of heat flow, so that the flow itself is interfered with as little as possible. The heat flux from the rocket shell (1), which is received by the heat conductor material (6), is then concentrated in the necking (7) and further received by the heat reservoir material (8). The heat flux measurement is carried out using two thermocouples (2), the position of which does not interfere with the heat flow path.

4. Numerical simulations

A thermal FEM analysis has been performed to allow for precise dimensioning of thermal experiment. The experiment itself is a series of concentric aluminium

rings, each of different dimensions and purpose. These include:

- thermal resistance, „necking”, marked as L1
- thermal capacitance, „container”, marked as L2
- (empty) cable feedthrough (min $\varnothing 30$ mm according to [3]), marked as D1

All dimensions are presented in Fig. 3.

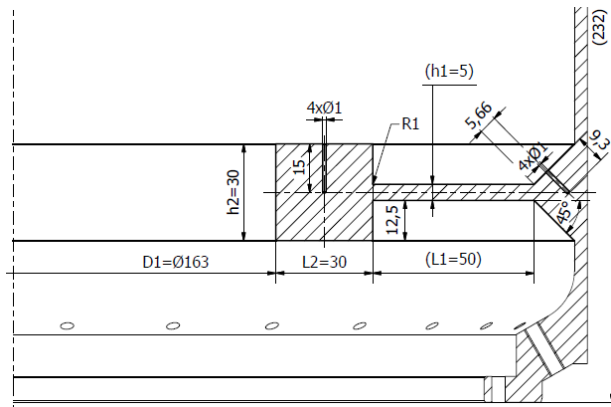

Fig. 3. CAD drawing of the device.

All of above are limited by the inner diameter of REXUS module $\varnothing 174$ mm [3]. Special consideration was taken to ensure best proportions between D1, L2 and L1 both from the point of view of scientific results and machinability.

As the thermal capacity of the experiment is considerable, temporal effects have to be taken into account, thus a non-linear transient thermal analysis has been performed. The model used for calculations is a module sector presented in Fig. 4 (already meshed).

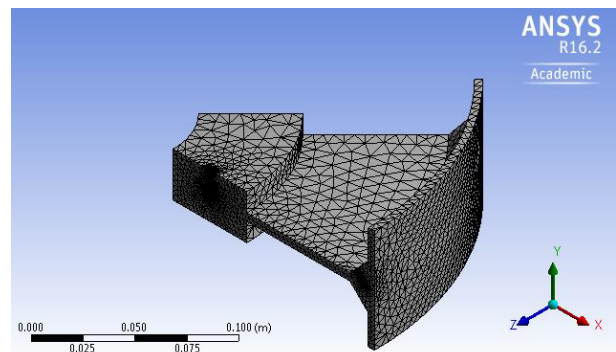

Fig. 4. Model used for thermal FEM analysis.

Also, thermocouples were carefully modelled using data from [1]. Note refined mesh near thermocouples in Fig. 5. Also, contact elements were used to model interface between the element and thermocouple itself. However, it turned out that the thermocouple influence on the experiment is negligible. In contrast, implementation of any other temperature sensor type

would have vastly perturbed the heat flow through the experiment.

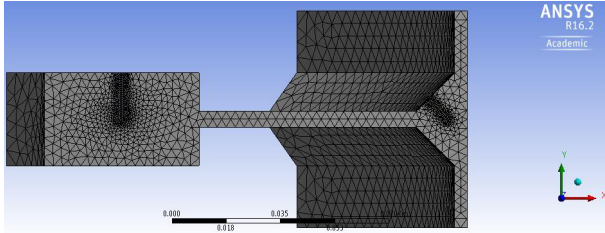

Fig. 5. Mesh refinement in the vicinity of the thermocouples.

The initial condition was defined as 14 °C, according to [1]. The boundary conditions were heat flux of 10000 W/m² on the rocket skin ramping from 0 to max value in 100 s and then ramping down from max value to 0 in next 100 s. All other walls were marked as perfectly insulated (as will be the case in real experiment). These wall are marked purple in the Fig. 6..

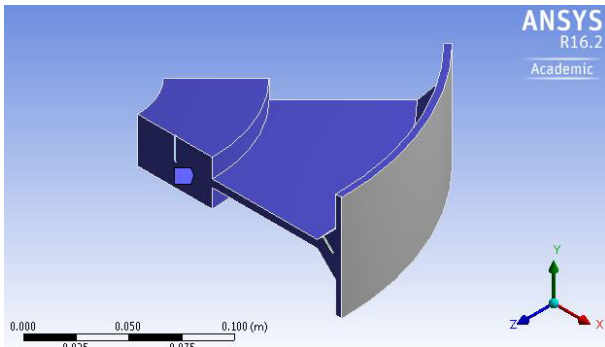

Fig. 5. Boundary conditions of thermal FEM analysis.

The analysis was performed for a number of parameters combinations. These were presented in Table 1.

Table 1. Thermal analysis computational cases

Case	Container length L2 [mm]	Necking length L1 [mm]
#1	10	50
#2	20	50
#3	30	50
#4	40	50
#5	50	50
#6	60	50
#7	30	10
#8	70	20
#9	30	30
#10	30	40
#11	30	50
#12	30	60
#13	30	70

For each of these points, $\Delta T(t)$ was calculated as difference of temperatures between thermocouples in function of time. Then, maximum value of this difference was calculated. Note that from the scientific point of view, the bigger the value, the better the experiment (as temperature difference ensures steady heat flow). The results were approximated by a 2d function (ΔT vs. L1 and L2). This allows for calculating ΔT for any combination of parameters L1 and L2. The error of approximation is less than half a degree Celsius. Results were presented in Fig. 6. and Fig. 7.

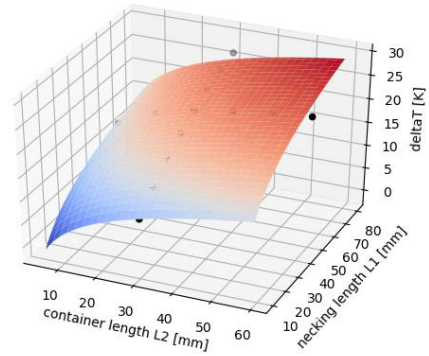

Fig. 6. Interpolation of FEM analysis for any combination of L1 and L2

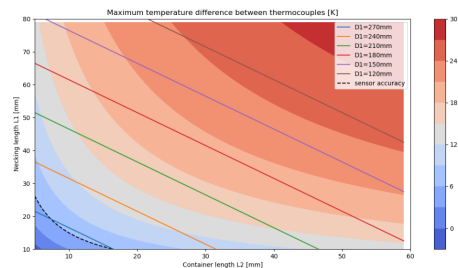

Fig. 7. Thermal experiment parameters interdependence.

Note that there is a limitation of ΔT (deltaT) that derives from sensors. Also, any given combination of L1 and L2 results in a required value of D1. This allows for trade-offs, discussed in further.

Fig. 7. shows a contour plot of ΔT in relation to parameters L1, L2 and D1. It can be noticed that the smaller D1 is, the bigger ΔT is, thus, the better the experiment is. An ideal value from machinability point of view, D1 = 270 mm (standard aluminium rod inner diameter) is just on the edge of experiment's sensibility. This is the reason for choice of D1 = 160 mm as a resulting value of ΔT allows for a high quality experiment.

Summing up, although the experiment does not generate any heat, special consideration will be given to separating thermal part from the rest so that neither disturbs each other's measurements.

5. Experiment design

A sounding rocket experiment has been prepared to validate the device in space conditions [4]. Fig. 8. shows a 3D model of the device.

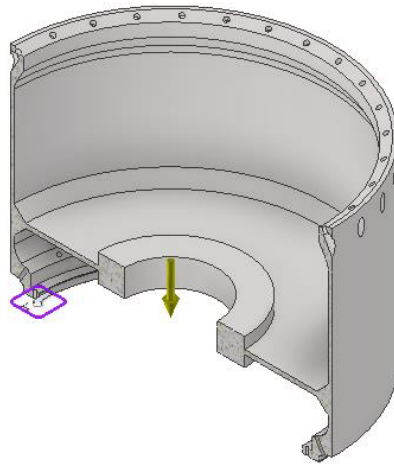

Fig. 8. Thermal experiment parameters interdependence.

An initial choice of styrofoam was abandoned due to contamination possibility and insufficient temperature range of the material. The insulation material was chosen to be 3M Thinsulate fabrics. It is a brand of synthetic fiber thermal insulation used in clothing. The word is a portmanteau of the words thin and insulate. The material is made by the 3M Corporation, and was first sold in 1979.

Thinsulate fibers are about 15 micrometres in diameter which is thinner than the polyester fibers normally used in insulation for clothing such as gloves or winter jackets. Advertising material suggests that Thinsulate is more effective due to the increased density of fibers with decreased size of fibers compared with more traditional insulation. Like most insulation materials, the gaps between fibers not only reduce heat flow, but also allow moisture to escape.

The material has thermal resistance $R = 0.09 \text{ m}^2\text{K}/\text{W}$, and thickness $d = 0.32 \text{ cm}$, so the coefficients of thermal conductivity can be calculated as $k = d/R = 0.036 \text{ W}/\text{mK}$. This is over 3500 more than that of Al7075-T6 ($k = 130 \text{ W}/\text{mK}$),

As Thinsulate is a fibre, a proper „pillow case” for the thermal experiment had to be sewn. Overlock stitch was applied at the edges to prevent the material from delamination. The insulation was also sewn together

with pieces of Duotec® velcro (guaranteed by manufacturer to survive 180 degrees Celsius). Fig. 9. shows the rocket module with the device and insulation.



Fig. 9. Insulation placed on thermal experiment.

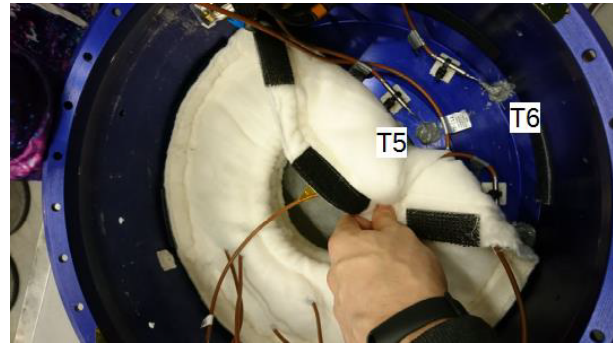

Fig. 10. Location of thermocouples T5 and T6.

6. Results

The data presented below is measurement from four thermocouples located as presented in figure below. T5 and T8 are thermocouples located closer to the center of the rocket and T6 and T7 are located closer to the rocket skin.

According to preflight analysis, temperatures T6 and T7 are expected to rapidly rise after launch, however the exact value of the rise was not known prior to flight and its measurement was one of the goals of the experiment. It was only assumed that maximum value would not reach 150 degrees, which was confirmed during flight. Temperatures T5 and T8 were also expected to rise during flight, however much slower and after a certain time lag. This is phenomenon is called thermal lag and is known in literature [7]. This was observed in HEDGEHOG data as well [4].



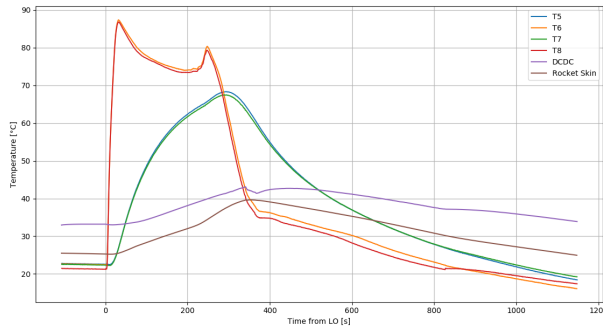

Fig. 11. Temperature data measured by HEDGEHOG experiment [4].

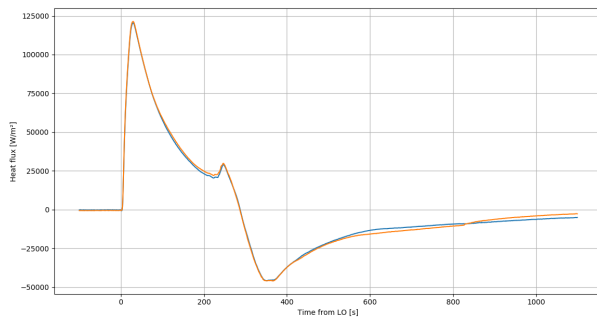

Fig. 12. Heat flux density on RX25 rocket skin measured by HEDGEHOG experiment [4].

Additionally, DCDC converter on the Main PCB temperature was measured as a diagnostic tool to detect possible overcurrent. The maximum allowed temperature on PCB was 80 degrees. Due to internal heating, it can be assumed that DCDC converter was the hottest element, yet it peaked at 43 degrees, proving that thermal design of PCB was perfect. A slight systematic difference can be noticed in thermocouple indications. This is due to intrinsic thermocouple manufacturing process.

The temperatures measured during HEDGEHOG experiment can be used, due to the principle of the design, to calculate heat flux density on rocket skin. This is of substantial interest for any future REXUS team. The temporal profile of heat flux density can be used as a boundary condition when solving direct heat transfer problem in software such as LISA or ANSYS. Temporal profile of temperature was presented in Fig. 11 and heat flux density on rocket skin was presented in Fig. 12.

Acknowledgements

This work has been funded by "Najlepsi z najlepszych 4.0" grant by the Ministry of Education and Science of Poland, MeiN/2021/234/DIR/NN4. Calculations were carried out at the Centre of Informatics Tricity Academic Supercomputer & Network

References

- [1] ECSS-E-HB-31-03A Thermal analysis handbook (15 November 2016), European Consortium for Space Standardization.
- [2] Kontinos, D. (1997). Coupled thermal analysis method with application to metallic thermal protection panels. *Journal of Thermophysics and Heat Transfer*, 11(2), 173-181.
- [3] Dąbrowski A., Dąbrowski L. (2019), Method for measuring of variability of the stream of heat from the tested surface, preferably from the space rocket shell, Polish Patent, application no. P.423198, granted 2019-06-11
- [4] Dąbrowski, A., Pelzner, K., Krawczuk, S., Goczkowski, J., & Elwertowska, A. (2020). Preliminary results from HEDGEHOG REXUS project—A sounding rocket experiment on accelerations, vibrations and heat flow. *Acta Astronautica*, 177, 80-85. DOI: 10.1016/j.actaastro.2020.07.016.
- [5] Alifanov, O. M. (1994). Analysis of Statements and Solution Methods for Inverse Heat Transfer Problems. In *Inverse Heat Transfer Problems* (pp. 33-69). Springer, Berlin, Heidelberg.
- [6] Grulich, M., Koop, A., Ludewig, P., Gutmiedl, J., Kugele, J., Ruck, T., & Dietmann, K. (2015, June). Smard-rexus-18: Development and verification of an sma based cubesat solar panel deployment mechanism. In *22nd ESA Symposium on European Rocket and Balloon Programmes and Related Research* (Vol. 730, p. 421).
- [7] Tzou, D. Y., & Guo, Z. Y. (2010). Nonlocal behavior in thermal lagging. *International Journal of Thermal Sciences*, 49(7), 1133-1137.