

## An overview of Multiple-Input Multiple-Output (MIMO) systems

KRZYSZTOF BRONK<sup>1</sup>, ADAM LIPKA<sup>1</sup>, RYSZARD J. KATULSKI<sup>2</sup>, JACEK STEFAŃSKI<sup>2</sup>

<sup>1</sup> National Institute of Telecommunications  
Marine Telecommunications Department  
Jaskowa Dolina 15, 80-252 Gdańsk  
e-mail: <K.Bronk, A.Lipka>@itl.waw.pl

<sup>2</sup> Gdansk University of Technology  
Department of Radiocommunications Systems and Networks  
Narutowicza 11/12, 80-952 Gdańsk  
e-mail: <rjkat, jstef>@eti.pg.gda.pl

Received 2007.08.20  
Authorized 2007.10.04

In this article, a novel multiple-input multiple-output (MIMO) technology is presented. MIMO is a technique that gives the opportunity to achieve very high data rates in radio networks, thanks to utilizing numerous spatial channels, resulting from the use of many antennas on one or both sides of the radio link. In the first part of this article, we describe the basic facts referring to MIMO, including the major benefits from using this technology (out of which diversity and multiplexing gains are arguably the most significant). After that, the mathematical background of MIMO is briefly outlined. The subsequent part refers to one of the most significant issues connected with multiple-antenna systems, that is the channel capacity. Employing MIMO allows to increase this capacity and consequently to boost transmission rate. Basic definitions and formulas for capacity in different cases are provided. The next part explains two most common methods of transmission, i.e.: spatial multiplexing and space-time coding. Finally, in the last part we summarize and conclude the article.

**Keywords:** multiple-input multiple-output, MIMO, channel capacity, spatial multiplexing, space-time coding

### 1. INTRODUCTION

In this article, the theoretical basics of multiple-antenna systems will be provided. In the most intuitive approach, these systems utilize transmission, reception, or both

transmission and reception using many antennas. In the first case, we say about transmit diversity and MISO systems (Multiple Input Single Output); in the second case – about receive diversity and SIMO systems (Single Input Multiple Output), and finally in the third case – we say about MIMO systems (Multiple Input Multiple Output). Thanks to using many antennas in the radio link, several benefits referring to quality of a system and achievable transmission rates are gained without the need for the increase of frequency band, delays or number of carrier frequencies.

In general, there are two basic ways of transmission in multiple-antenna systems, i.e.: spatial multiplexing which assumes that different information are broadcast by different antennas, and space time coding in which the same information (appropriately encoded) are sent by multiple antennas according to a strictly defined pattern.

In spatial multiplexing, transmission from each of the transmit antennas is realized in the same frequency band and at the same time (simultaneously), so incomparably more information can be broadcast at any given moment of time than in the case of only one transmit antenna (to be precise: up to  $M$  times more information, where  $M$  denotes the number of transmit antennas). In other words: the utilization of the band is  $M$ -times more efficient, and the whole stream spread over  $M$  antennas is transmitted up to  $M$ -times faster. In case of space-time coding, the main benefit of this technique is the increase of the overall quality of transmission by decreasing bit error rate (BER). When the appropriately encoded (in time and space) information is sent from many antennas, the receiver will use numerous replicas to make a decision, and even if some of those replicas are distorted due to transmission in a radio channel, it will not degrade the quality to such an extent as it would in the case of a single-antenna system (SISO). Both spatial multiplexing and space-time coding will be analyzed in greater details in the further part of this article.

The MIMO systems are based on spatial separation of multiple streams containing original data. Information are sent over spatial subchannels, whose number depends on the number of antennas at both sides of the link. It is noteworthy that multiple-antenna technique exploits multipath propagation in a positive way. This phenomenon has been considered to be definitely a negative one for a very long time, and many research have been carried out in order to minimize its destructive influence on transmission quality. This time, however, environment with rich multipath propagation is the most desired one for multiple antenna systems since it provides the possibility to distinguish and separate multiple substreams and to increase channel capacity which is one the most significant features of MIMO systems.

Th  
tennas

The  
tems, i.e.  
rence. In

Arra  
receiver.  
antennas  
the avera  
multiple  
gain requ  
the numb  
such sign  
maximiz  
knowledg  
whereas  
systems.

Diver  
signal (in  
even if th

## 2. THEORY AND TECHNIQUE OF THE MIMO SYSTEMS

### 2.1. THE MAJOR BENEFITS OF MIMO SYSTEMS

The conceptual scheme of a MIMO system using  $M$  transmit and  $N$  receive antennas is depicted in Fig. 1.

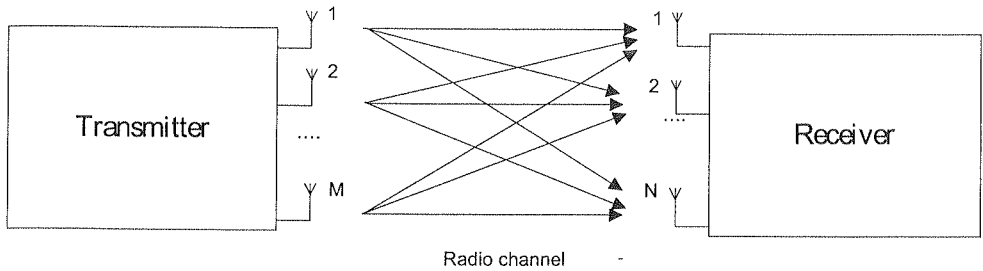

Fig. 1. An intuitive definition of a multiple-input multiple-output system

There are 4 phenomena which result in performance enhancement in MIMO systems, i.e.: array gain, diversity gain, spatial multiplexing gain and co-channel interference. In the following part they will be briefly described [1].

#### 2.1.1. Array gain

Array gain is a result of signal processing in transmitter (beamforming) and/or receiver. For instance in transmitter it comes down to forming the signal sent from antennas with so-called weight coefficients. This gain is expressed by the increase of the average SNR (signal to noise ratio) as a result of combining signals (replicas) from multiple antennas (these signals are added up in the receiver). Transmit/receive array gain requires channel knowledge in transmitter or receiver, respectively, and depends on the number of antennas. Channel knowledge is necessary since it enables to implement such signal processing algorithms which would reflect a current channel state and thus maximize benefits resulting from this kind of processing. Obviously, obtaining channel knowledge in the receiver is relatively easy to perform (e.g. with training sequences), whereas in the transmitter – much more difficult and requires so-called closed-loop systems.

#### 2.1.2. Diversity gain

Diversity gain is a result of using multiple spatial paths for transmission of the signal (in ideal case, paths should be independent from one another). In that case, even if the quality of signal carried by one of the paths is bad, the other paths can

still be exploited to decode the information correctly, and the bit error rate will not be influenced as severely as it would happen in the SISO system. In general, diversity is used to reduce the negative influence of fading in the radio link. If we consider the system depicted in Fig. 1, we can easily notice that there are  $M \times N$  spatial channels (paths) altogether which can be used to transmit information. Assuming that:

- fadings in each of these channel are independent (uncorrelated),
- transmitted signal has appropriate features,

the amplitude fluctuations of the resulting signal (containing replicas from each paths) will be reduced comparing to the SISO system.

To achieve diversity, one might exploit paths that are independent in either time, frequency or space. Out of these three options, the third one seems to be optimal as it does not require longer time of transmission or wider bandwidth.

In order to maximize spatial diversity without channel knowledge in transmitter (the most common case) we use the special signals (codewords), created as a result of space-time coding.

### 2.1.3. Multiplexing gain

MIMO technique can be employed to increase channel capacity. In general, this increase is linear and proportional to  $\min(M, N)$  and is obtained due to spatial multiplexing. This technique (unlike space-time coding) assumes sending different (independent) signals by different transmit antennas. It is realized in systems like BLAST, where data stream is divided into  $M$  layers (substreams) broadcast simultaneously by  $M$  antennas.

Each of the mentioned layers due to radio channel influence can be unambiguously distinguished by the so-called spatial signatures (representing distortion of each of the individual radio subchannels). These signatures are used in the receiver to separate the layers, prior to their decoding. For this reason, it is crucial to ensure the proper environment with rich scattering, where multipath propagation is strong, because in such conditions paths reaching the receiver will be most distinguishable, and consequently, multiplexing gain will be maximized.

There are many different techniques of spatial multiplexing that vary in the way of separating and processing substreams, but most of them are highly sophisticated and complicated in terms of the relevant algorithms and required processing resources, which in some cases might make their implementation much harder or even impossible. It should also be noted that systems using spatial multiplexing require at least the same number of antennas in the receiver as in the transmitter (in contrast to systems with space-time coding which provide diversity gain even with a single receive antenna). This requirement results in considerable costs increase due to the necessity of implementing redundant elements in both parts of the transceiver.

Co  
many t  
encies  
of this  
channe  
need to  
the tran  
that mi  
hand, r  
it is po  
system

We  
To begi  
and rec

A r  
antenna  
is descr  
channel  
the sign  
denotes

<sup>1</sup> In th

2.1.4. Co-channel interferences reduction

Co-channel interferences are caused by frequency reusing (frequencies are used many times in cells according to a particular pattern, and cells using the same frequencies interfere with one another). Employing MIMO technique can yield reduction of this effect thanks to the already mentioned spatial signatures which reflect radio channel influence on a given signal path. In order to distinguish the desired signal, one need to have its channel knowledge. Co-channel interference reduction is achievable in the transmitter and is realized by an appropriate signal processing, such that the signal that might be received by co-channel users is maximally attenuated and, on the other hand, maximally amplified in the direction of desired users. Obviously, in that case it is possible to use the same frequencies more often, and consequently – to increase system capacity.

2.2. THE MATHEMATICAL DESCRIPTION OF THE MIMO SYSTEMS

We shall now take a closer look at the functioning of multiple antenna systems. To begin with, we will analyze a system with a two antennas at both the transmitter and receiver ( $M = 2$  and  $N = 2^1$ ) (Fig. 2).

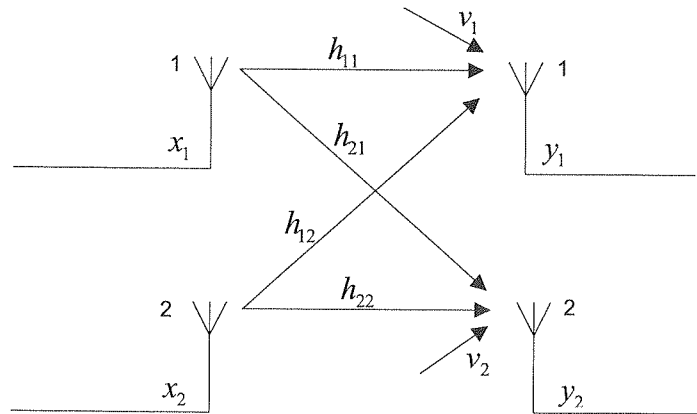

Fig. 2. MIMO system (2 transmit, 2 receive antennas)

A modulated radio signal  $x_j$  ( $j = 1, 2$ ) propagating between transmit and receive antenna is attenuated and phase shifted. The radio channel's influence on this signal is described by the channel impulse response  $h_{ij}$ , where the element  $h_{ij}$  represents the channel between  $j$ -th transmit antenna and  $i$ -th receive antenna. Let  $x_j(t)$  denote the signal transmitted in time  $t$ , and  $y_i(t)$  ( $i = 1, 2$ ) represents the received signal.  $n_i(t)$  denotes white additive noise influencing the signal.

<sup>1</sup> In this article, M-means the number of transmit antennas, N-means the number of receive antennas.

In this case, channel (i.e. spatial propagation paths) characteristic is represented by the following matrix.

$$\mathbf{H} = \begin{bmatrix} h_{11} & h_{12} \\ h_{21} & h_{22} \end{bmatrix} \tag{1}$$

Consequently, we can define the set of equations valid for the analyzed system:

$$\begin{aligned} y_1(t) &= h_{11} \cdot x_1(t) + h_{12} \cdot x_2(t) + n_1(t) \\ y_2(t) &= h_{21} \cdot x_1(t) + h_{22} \cdot x_2(t) + n_2(t) \end{aligned} \tag{2}$$

which can be expressed in the matrix form

$$\mathbf{Y} = \mathbf{H} \cdot \mathbf{X} + \mathbf{N}, \tag{3}$$

where  $\mathbf{Y} = [y_1, y_2]^T$  – denotes the vector of received symbols,  $\mathbf{X} = [x_1, x_2]^T$  – denotes the vector of transmitted signals,  $\mathbf{N} = [n_1, n_2]^T$  – denotes the noise vector.

As we shall later explain, the transmission in the systems like in Fig. 2 is equivalent to a transmission over two independent radio channels which share the same frequencies and results in two-time increase of spectral efficiency. Thanks to a couple of antennas at both radio link sides we can transmit the information twice as fast (ideally) as in classic SISO system. The actual increase of the spectral efficiency (and thus – data rate) depends upon mutual independence (or lack of correlation) of each radio link.

As mentioned before, in practical implementations to achieve large spectral efficiency values, the spatial multiplexing is employed (most common, in the form of BLAST systems: V-BLAST, D-BLAST).

Let us analyze the system in Fig. 2 one more time and expand it to M transmit and N receive antennas. In that case the channel matrix will be as follows:

$$\mathbf{H} = \begin{bmatrix} h_{11} & h_{12} & \cdots & h_{1M} \\ h_{21} & h_{22} & \cdots & h_{2M} \\ \vdots & \vdots & \ddots & \vdots \\ h_{N1} & h_{N2} & \cdots & h_{NM} \end{bmatrix} \tag{4}$$

On the other hand, the signal received by the  $i$  – th antenna, under the assumption that the  $j$  – th transmit antenna sent  $x_j(t)$ , can be presented in such a way:

$$y_i(t) = \sum_{j=1}^M h_{ij}x_j(t) + n_i, \quad j = 1, 2, \dots, N \tag{5}$$

To sum up the above introductory description we should underline two main goals of the MIMO technology. Firstly, it is quality of transmission improvement, i.e. bit error rate reduction achieved by space-time coding; and secondly, a noticeable spectral efficiency increase, which yields noticeable transmission rate improvement due to spatial multiplexing.

2.3. CHANNEL CAPACITY OF THE MIMO SYSTEMS

In this paragraph, we describe one of the most important issues connected with multiple antennas technique. A possibility of achieving much higher capacities, considerably exceeding values gained in classic systems (SISO systems), is one of the major merits of this technology. After a theoretical introduction, methods of channel capacity assessment will be presented:

- with an assumption that channel is deterministic (only one realization of the channel is considered, which is true only in the given time),
- for a flat fading channel,

We will define an analytical expression describing channel capacity of MIMO systems. But as a reference we will begin with a capacity of a classic system SISO, for which a matrix  $\mathbf{H}$  is a scalar ( $\mathbf{H} = h$ ) known in a receiver. It can be calculated as follows [5, 6]:

$$C_{SISO} = \log_2(1 + \rho |h|^2), \tag{6}$$

where  $\rho$  denotes a ratio between the signal power and the noise power expressed in a linear scale.

The above relation results in a conclusion that the capacity of the SISO system grows logarithmically with a growth of a ratio of signal power to noise power. Consequently, if we want to increase the capacity by for example 10 bit/s/Hz we would have to increase SNR approximately 1000 times [5].

For a SIMO channel the matrix  $\mathbf{H}$  is expressed as  $\mathbf{H} = [h_1, h_2, \dots, h_N]^T$ . In this case the capacity can be obtained from [5, 6]:

$$C_{SIMO} = \log_2(1 + \rho |\mathbf{H}|^2) = \log_2\left(1 + \rho \sum_{i=1}^N |h_i|^2\right). \tag{7}$$

In case of the multiple antennas in the receiver, and only the single antenna in the transmitter, the growth of the capacity is logarithmical and depends on a number of the antennas in the receiver.

In case of a MISO channel, the matrix  $\mathbf{H}$  can be expressed as:  $\mathbf{H} = [h_1, h_2, \dots, h_M]$  and the channel capacity is defined as follows [5, 6]:

$$C_{MISO} = \log_2\left(1 + \frac{\rho |\mathbf{H}|^2}{M}\right) = \log_2\left(1 + \rho \frac{\sum_{i=1}^M |h_i|^2}{M}\right). \tag{8}$$

For a MISO channel, the growth of the number of the antennas in the transmitter does not result in any growth of its capacity.

The last possibility is the MIMO channel. We assume here that the receiver possesses a complete information about a channel state (matrix  $\mathbf{H}$ ) and we treat this

information as a deterministic one. We can now calculate the channel capacity using an expression [1, 6, 7]:

$$C_{MIMO} = \log_2 \left[ \det \left( \mathbf{I}_N + \frac{\rho}{M} \mathbf{H}\mathbf{H}^H \right) \right], \quad (9)$$

where:  $\det(\cdot)$  – determinant of a matrix,  $\mathbf{I}_N$  –  $N \times N$  identity matrix ( $N$  – a number of receive antennas),  $(\cdot)^H$  – conjunction and transposition of a matrix.

We can often encounter a simplified assumption that the matrix  $\mathbf{H}$ , which describes a channel, for large values of  $M$  and a fixed value of  $N$  can be presented as [8]:

$$\frac{1}{M} \mathbf{H}\mathbf{H}^H = \mathbf{I}_N. \quad (10)$$

Let us assume the same number of the antennas at both sides of a radio link ( $M = N$ ). We can now exploit the equation (9) to transform the expression (10). Now it is easy to notice that:

$$C_{MIMO} = \log_2 [\det(\mathbf{I}_N + \rho \cdot \mathbf{I}_N)] = \log_2 \{ \det [\mathbf{I}_N (1 + \rho)] \}. \quad (11a)$$

On the basis of a matrix algebra it is well known that:  $\det(\mathbf{I}_n \cdot q) = q^n$ , where  $q$  is the scalar and  $\mathbf{I}_n$  is  $n \times n$  identity matrix. Then after a further transformation of the expression (9) we obtain:

$$C_{MIMO} = \log_2 (1 + \rho)^N = N \cdot \log_2 (1 + \rho) = N \cdot C_{SISO}. \quad (11b)$$

It shows that for MIMO system a relation between the capacity and the number of antennas is linear [7]. We showed analytically that for the multiple antennas system the capacity of the channel grows theoretically  $N$ -times in comparison with the capacity of the SISO system. In general, this growth is proportional to  $\min(M, N)$ , which was mentioned before in this article.

The above analysis can be further enhanced by making an eigenvalues decomposition of the matrix product  $\mathbf{H}\mathbf{H}^H$ , which can be expressed as:

$$\mathbf{H}\mathbf{H}^H = \mathbf{E}\mathbf{\Lambda}\mathbf{E}^H, \quad (12)$$

where:  $\mathbf{E}$  – matrix of eigenvectors,  $\mathbf{\Lambda}$  – diagonal matrix containing the eigenvalues on a main diagonal.

Using the equation (12), and keeping in mind that  $\det(\mathbf{I}) = 1$ , we can now calculate the capacity of the MIMO system as follows:

$$C_{MIMO} = \sum_{i=1}^{\text{Rank}} \log_2 \left( 1 + \frac{\rho}{M} \lambda_i \right), \quad (13)$$

where: Rank – matrix rank ( $\text{Rank} \leq \min(M, N)$ ),  $\lambda_i$  – positive eigenvalues of the product  $\mathbf{H}\mathbf{H}^H$  ( $i = 1, 2, \dots, M$ ).



The expression (13) results in an important conclusion. The capacity of the MIMO channel can be interpreted as a sum of parallel SISO channels' capacities whose gains are expressed by the parameters  $\lambda_i$ . To maximise the channel capacity it is desired to ensure as many of the eigenvalues to be nonzero and big as possible.

Similar conclusion can be derived from SVD (Singular Value Decomposition) decomposition of the matrix  $\mathbf{H}$ , which can be exploited instead of the eigenvalue decomposition [8]. As a result the simplest MIMO system (MIMO(2,2)) can be represented in a way shown in Fig. 3.

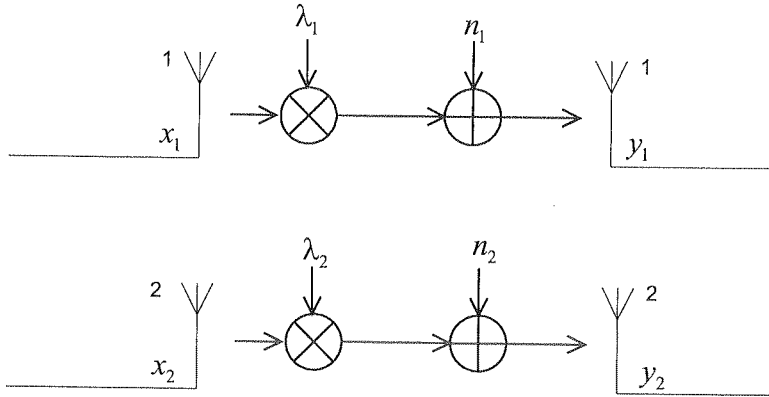

Fig. 3. The MIMO(2,2) system interpreted as two independent and parallel SISO channels

The all above analysis where done with an assumption that the channel is deterministic. Reality is different, however, because we have to consider the fading channel which causes fluctuations of the  $h_{ij}$  values. In such a situation, we need to use a bit different approach to estimate the channel capacity.

Two classes of the capacity can be defined i.e.: an ergodic capacity and an outage capacity. In the first case, through calculating an expected value of the expression (9), an average MIMO channel capacity can be obtained as [1]:

$$C_{ergodic} = E \left\{ \log_2 \left[ \det \left( I_N + \frac{\rho}{M} \mathbf{H}\mathbf{H}^H \right) \right] \right\}, \tag{14}$$

where  $E(\cdot)$  denotes an average (expected) value. On the other hand, the outage capacity  $C_{out,q}$  describes the throughput which is ensured with the probability  $(100 - q)\%$  (for  $(100 - q)\%$  realizations of the radio channel) i.e. [1]:

$$P(C \leq C_{out,q}) = q\%, \tag{15}$$

where  $P(C \leq C_{out,q})$  denotes the probability (P) of the event that the capacity (C) will not exceed the outage capacity ( $C_{out,q}$ ). In this case the capacity can be interpreted as a random variable which value depends on a temporary channel state (its impulse response). The probability in the expression (15) denotes that for the  $q\%$  of the chan-

nel's realizations (the different channel's responses) the value of the capacity will drop below a threshold indicated by the outage capacity  $C_{out,q}$ .

### 3. METHODS OF TRANSMISSION IN MIMO SYSTEMS

#### 3.1. SPATIAL MULTIPLEXING

Spatial multiplexing is one of the most common techniques of transmission being utilized in MIMO systems. In general, it comes down to transmitting  $M$  independent data symbols in a single symbol period. As a result,  $M$ -times more information can be broadcast per second than in a single-antenna system operating at the same data rate. To this end, there is no need to increase either the number of carriers or transmitting power, which is an additional benefit. In practical solutions, spatial multiplexing is performed by dividing a single input stream into  $M$  substreams (often referred to as "layers"), which are simultaneously broadcast by transmit antennas.

As of now, several algorithms of spatial multiplexing have been proposed; the main difference between them is a way of dividing a stream into substreams and methods of subsequent signal processing for each of substreams. Chronologically, the first spatial multiplexing algorithm was so-called Layered-Space-Time architecture (LST) or D-BLAST (Diagonal – Bell Labs Layered Space Time Architecture) proposed in 1996 by Gerard Foschini [9, 10]. It offers very high spectral efficiency values, and thus impressive data rates, but at the same time it is very computationally demanding and inefficient, which limits the possibility of its practical implementations. For this reason, it was necessary to find novel solutions which would constitute a convenient trade-off between capabilities and efficiency of the given method.

In the receiver, in most cases, decoding is performed separately for each of the layers, so it is necessary to first separate these layers from the received signal. At the moment, there are several ways to conduct this algorithmically convoluted processes. It should be noted that the choice of a given decoding method influences the overall quality of the system.

In the following part we will briefly outline the most common algorithms of spatial multiplexing.

##### 3.1.1. H-LST Algorithm

Horizontal LST (H-LST) [1, 10, 11] is the simplest algorithm of spatial multiplexing. The main idea can be described in the following way: the input data stream is divided into  $M$  substreams (layers) in a serial to parallel converter (S/P). After that, bits belonging to the given substream are encoded (block or convolutional encoding), modulated and interleaved. After such a processing, the signals from each layer are transmitted from a selected antenna; it should be noted, however, that antenna-substream



association remains the same in time. Spatial rate (defined as the number of independent symbols in a transmitted word divided by the frame length) equals  $M$  for H-LST, and diversity gain is only  $N$  (any information bit can be transmitted by only one, selected antenna but can be received by all  $N$  receive antennas). For this reason, H-LST is not an optimal architecture but it strongly simplifies the structure of the receiver.

The transmitter of H-LST system is depicted in Fig. 4, and the antenna-substream association – in Fig. 5, where a number represents the number of layer from which symbols are transmitted in a given moment of time and through a given antenna.

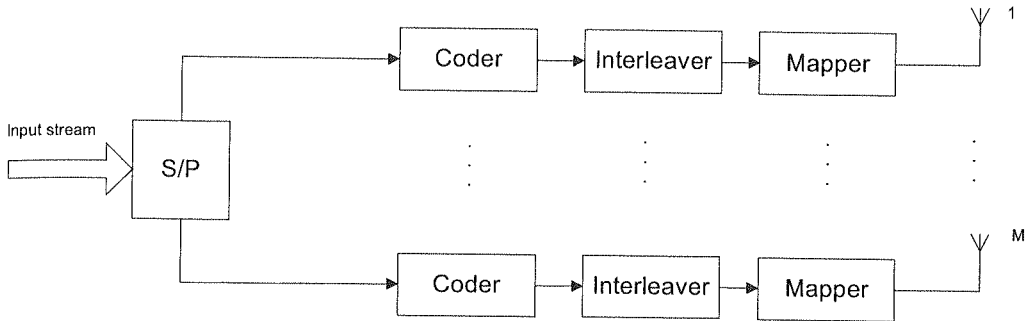

Fig. 4. H-LST transmitter. (S/P – serial to parallel converter, M – number of transmit antennas)

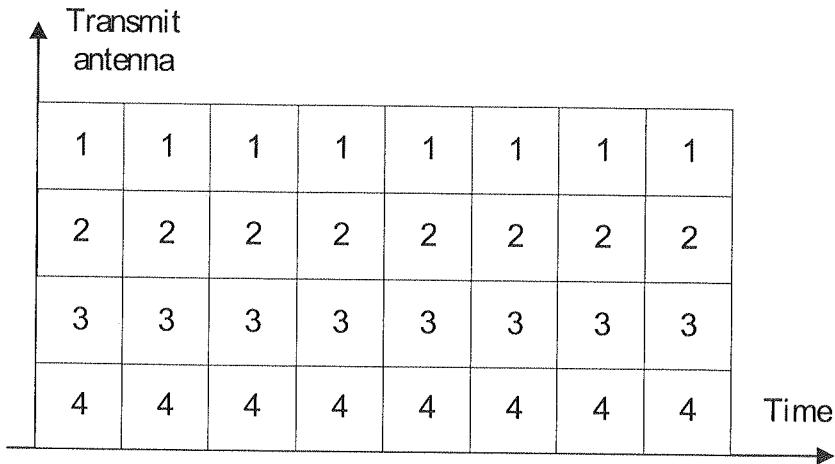

Fig. 5. Stream-antenna association for H-LST systems

### 3.1.2. V-LST Algorithm

In the vertical LST algorithm [1], the input stream is encoded, modulated and interleaved prior to the eventual demultiplexing into  $M$  substreams, which is the major difference between this technique and the H-LST.

The stream-antenna association is in general the same as for H-LST (Fig. 5), however due to the reversed order of encoding and demultiplexing, the information of any input bit can be carried by streams associated to various antennas, so, unlike in H-LST, a single bit may be "spread" across every transmit antenna, which yield maximum diversity gain of  $M \times N$ .

This algorithm offers additional coding gain (its value depends on the exploited code), and the spatial ratio of V-LST is  $M$  (like in H-LST).

Another technique which stems from the V-LST is an algorithm called V-BLAST [12]. In this case, the branches of transmitter are the QAM mappers, and the stream processing is simply bit demultiplexing, but in contrast to V-LST, mapping is performed for each layer independently. The V-BLAST technique does not require any coding, either of the substreams or any other, however if necessary – may be implemented. The scheme of the V-BLAST transmitter is shown in Fig. 6.

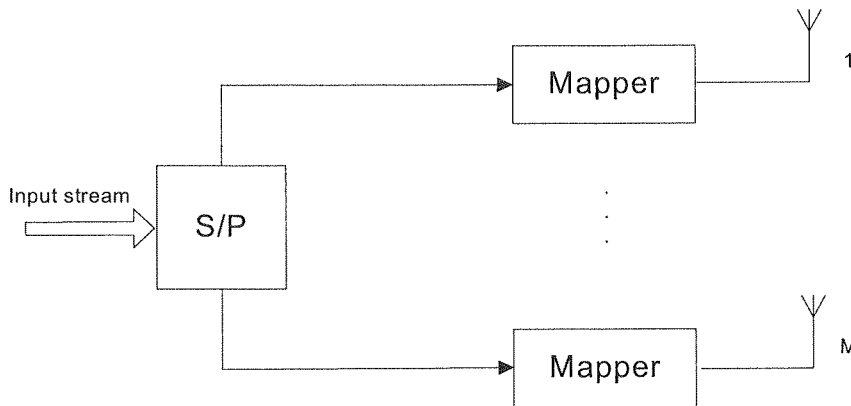

Fig. 6. V-LST Transmitter (S/P – serial to parallel converter,  $M$  – number of transmit antennas)

V-BLAST is known for ensuring tremendous values of spectral efficiency. In ref. [12, 13] it is claimed that during laboratory indoor research, the spectral efficiency values of 20 – 40bit/s/Hz for SNR of 24-34dB were achieved.

### 3.1.3. D-BLAST Algorithm

The diagonal BLAST is an algorithm where the two above techniques (H-LST and V-LST) converge. The transmit system can be described in the following way. The input stream is demultiplexed into  $M$  layers and each layer is encoded and mapped onto symbols. Those symbols are afterwards associated to the antennas in a diagonal manner, which means that for D-BLAST, the stream-antenna association is not fixed and varies in time. For  $M=4$ , such an association can be described like in Fig. 7.

The main drawback of the algorithm is a wastage of some time and spatial resources due to initial lack of transmission (indicated by the shaded area in the Fig. 7).

Such an  
wasted s  
To a  
choose a  
streams  
Likelihoo  
additional  
of these  
levant rel  
detector c  
requireme  
solutions  
use the m

Space  
a techniqu  
method. It  
designed c  
quality is  
same data  
copies in  
through ex  
assignment  
assignment

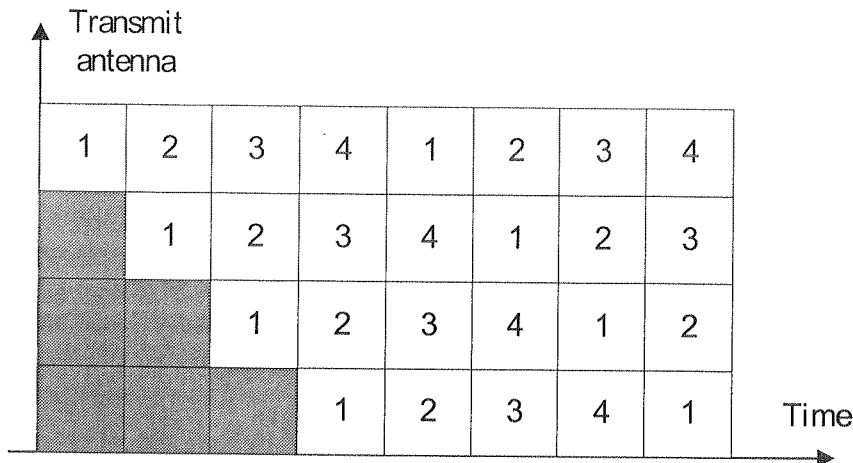

Fig. 7. Stream-antenna association for D-BLAST systems

Such an approach results in simplifying the receiver structure but the losses of these wasted slots are critical and non-negligible especially for short blocks of information.

To achieve all the benefits offered by spatial multiplexing systems, it is vital to choose a proper receive algorithm, which will enable to separate and decode the sub-streams most reliably and efficiently. Some of the known algorithms are Maximum Likelihood and Minimum Mean Square Error decoding, Zero-Forcing receiver, and additionally Successive Cancellation and Ordered Successive Cancellation. The theory of these algorithms is well beyond the scope of this article and can be found in relevant references (eg. [1]). It should be noted however that the Maximum Likelihood detector offers the best quality results but at a price of very high computational power requirements; on the other hand MMSE algorithm proves to be the worst. In practical solutions these methods are often joined, for example in V-BLAST it is proposed to use the method which benefits from ZF and OSUC algorithms.

### 3.2. SPACE-TIME CODING

Space-time coding is another way of transmission in the MIMO systems. It is not a technique which increases the channel capacity as it was for the spatial multiplexing method. Its main purpose is to achieve a maximum diversity gain through a properly designed codes. As a result, we get decrease of the bit error ratio (BER) – a transmission quality is improved. A diversity maximization can be achieved thanks to sending the same data (properly encoded) by each transmit antenna and correct assembling signal copies in the receiver. Information bits are mapped onto complex symbols obtained through exploiting a proper constellation. Meanwhile, the MIMO coder specifies an assignment of these symbols between transmit antennas in successive time slots. The assignment is often presented as a matrix whose successive rows describe the successive

time moments and columns represent the respective transmit antennas. It is noteworthy that if fading in all spatial subchannels will be uncorrelated then for the MIMO(M,N) system we achieve maximal diversity, that is M·N. It can be interpreted as a number of propagation paths of the signal and also as a number of the signal copies obtained in the receiver.

In practice, we can distinguish two types of space-time coding:

- Space-Time Trellis Coding (rarely used in practice),
- Space-Time Block Coding.

The space-time block coding (STBC) is the most common way of a realization of the space-time coding for the multiple antennas systems. An important task here is to design the optimal codes, which will determine the quality of STBC. Major criteria are [15]:

- An assurance of possibly big diversity (characterized by a number of an independent channels in which respective symbols are transmitted);
- A spatial code rate (a number of the transmitted symbols with respect to a length of a space-time block);
- A delay (the length of the block of the space-time code).

Most often, it is desired to achieve the maximum spatial code rate and the minimal delay with the assurance of full diversity. The codes, which are utilized for the purpose of the STBC technique, are created on the basis of an orthogonal design [16]. Generally, for the real constellations, the matrix describing an orthogonal code is a  $n \times n$  square matrix. An orthogonality can be achieved only for specific values of  $n$  ( $n = 2, 4$  or  $8$ ). The full spatial code rate can only be obtained when the orthogonality is ensured.

### 3.2.1. Alamouti Code

Alamouti code [17] is a quite simple code related to the case with two transmit antennas. It offers the full spatial code rate and its matrix is:

$$\begin{bmatrix} s_1 & s_2 \\ -s_2^* & s_1^* \end{bmatrix}. \quad (16)$$

This coding can be described as follows: there is a complex constellation consisted of  $2^b$  signals. During the first time slot, the coder gets  $2b$  bits which decide about choosing two complex symbols  $s_1$  and  $s_2$ . These symbols are simultaneously transmitted through both antennas. During the second time slot symbols  $-s_2^*$  and  $s_1^*$  are transmitted through both antennas (Fig. 8).

*Example:*

Let us consider a system with two transmit antennas and with QPSK modulation whose constellation is depicted in Fig. 9. We can now assume a following sequence of the symbols: {0 1 1 3} or in binary form: {00 01 01 11}. In the first time slot the Alamouti coder gets two first symbols: 0 (00)<sub>2</sub> and 1 (01)<sub>2</sub>. According to the assumed

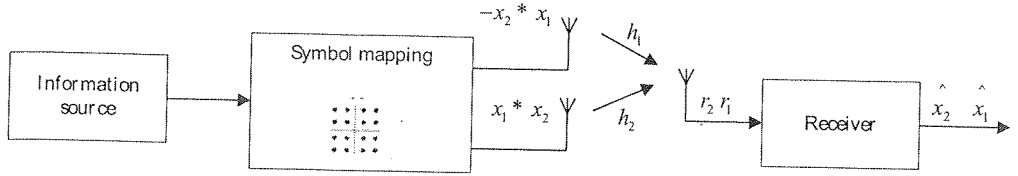

Fig. 8. A simplified scheme of the MIMO(2,1) system with the Alamouti coding

constellation, the symbol '0' is mapped onto  $s_1 = 1$  and '1' onto  $s_2 = j$ . During the transmission in the first time slot the sequence  $\{s_1$  (first antenna) and  $s_2$  (second antenna)}, that is  $\{1, j\}$ , will be sent, then in the second time slot the sequence  $\{-s_2^*$  (first antenna) and  $s_1^*$  (second antenna)}, that is  $\{j, 1\}$ , etc.

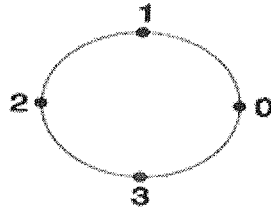

Fig. 9. The assumed QPSK constellation

The Alamouti coding can be then described as follows:

Inputsequence : 0 1 1 3  
 Firstantenna : 1 j j -j  
 Secondantenna : j 1 -j -j

Let us consider a MIMO system with two transmit and two receive antennas. In that case, the signals received by each antenna can be defined, i.e.: the first receive antenna obtains, in the successive time slots, the signals  $r_1$  and  $r_2$  and the second one receives  $r_3$  and  $r_4$  (Fig. 10):

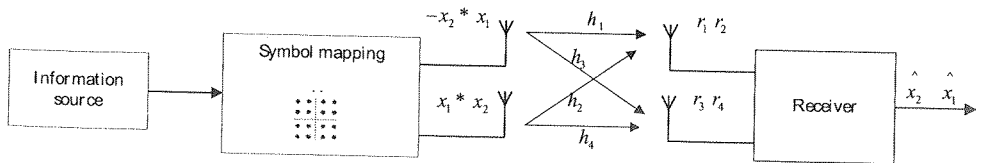

Fig. 10. A simplified scheme of the MIMO(2,2) system with the Alamouti coding

$$\begin{aligned}
 r_1 &= h_1s_1 + h_2s_2 + n_1 \\
 r_2 &= -h_1s_2^* + h_2s_1^* + n_2 \\
 r_3 &= h_3s_1 + h_4s_2 + n_3 \\
 r_4 &= -h_3s_2^* + h_4s_1^* + n_4
 \end{aligned}
 \tag{17}$$

In the receiver the two following signals are created:

$$\begin{aligned}
 \tilde{s}_1 &= h_1^*r_1 + h_2r_2 + h_3^*r_3 + h_4r_4^* \\
 \tilde{s}_2 &= h_2^*r_1 - h_1r_2^* + h_4^*r_3 - h_3r_4^*
 \end{aligned}
 \tag{18}$$

We can now substitute (17) into (18) and obtain the input signals passed then to the ML decoder:

$$\begin{aligned}
 \tilde{s}_1 &= (|h_1|^2 + |h_2|^2 + |h_3|^2 + |h_4|^2)s_1 + h_1^*n_1 + h_2n_2^* + h_3^*n_3 + h_4n_4^* \\
 \tilde{s}_2 &= (|h_1|^2 + |h_2|^2 + |h_3|^2 + |h_4|^2)s_2 - h_1n_2^* + h_2^*n_1 - h_3n_4^* + h_4^*n_3
 \end{aligned}
 \tag{19}$$

In last years, many research have been carried out which prove that multiple antenna systems with the Alamouti coding enable to achieve a given BER with much lower SNR that in case of a single antenna system (1,1) with no coding implemented. This reduction of the required SNR is the undoubted value of the technique. For example in [2] it was shown for a simple (2,1) system, a BER = 10<sup>-3</sup> is achieved for SNR 5dB lower that for SISO system. When two antennas were used at both ends of the radio link (the (2,2) system), the gain was even greater – we could reduce SNR by 18dB to achieve BER = 10<sup>-3</sup> in comparison to the single antenna systems. This proves how promising the space-time coding method is.

#### 4. CONCLUSION

Radio link is arguably the most inconvenient and toughest medium of transmission, and for this reason achieving high data rates in radio networks was considered as a difficult and sometimes even impossible task. Emerging of the MIMO technology can dramatically change this situation, and give the possibility to realize data rates that used to be achievable only in cable or optical networks. The key to success was to provide techniques of transmission that would ensure high level of spectral efficiency.

In this article, the basics of this novel, highly promising technology, were presented. We discussed the major benefits of utilizing MIMO, capacity formulas for different cases and finally two methods of transmission in MIMO systems, i.e. spatial multiplexing and space-time coding.

We can expect that in the future, MIMO as a system offering enormous data rates with more than sufficient quality will become common or even dominant in some branches of contemporary radiocommunications. At the moment, MIMO is included

Vol. 53  
 into L  
 used i  
 IEEE  
 multip  
 from t  
 a furth  
 aspect  
 change  
 and re  
 1. A.J.  
 edito  
 2. H. I  
 The  
 3. W.  
 Prze  
 4. R.J.  
 w te  
 5. H. I  
 6. D. C  
 Cod  
 281-  
 7. K. v  
 mej,  
 8. B. H  
 /proj  
 9. G.J.  
 Arch  
 10. G.J.  
 ment  
 11. D. S  
 Anter  
 12. P.W.  
 the R  
 13. G.D.  
 Comm  
 14. V. T  
 Criter  
 744-7  
 15. A. H  
 2003.  
 16. V. T  
 Inform  
 17. S.M.  
 Journa



into IEEE 802.16 (WMAN networks) standard as an option, and is proposed to be used in HSDPA (a subsystem of UMTS). Moreover, it is foreseen that in 2008, the IEEE 802.11n standard will be published, which will provide details of implementing multiple-antenna systems in WLAN networks. As we can see, the interest in MIMO from the major standardization organizations (IEEE, 3GPP), gives a “green light” for a further development of this technology. We can also expect that many theoretical aspects of MIMO, a few of which have been presented in this article, can evolve or change, so to stay up-to-date with MIMO, it is necessary to follow appropriate literature and references.

## 5. REFERENCES

1. A.J. Paulraj et al., *An Overview of MIMO Communications – A Key to Gigabit Wireless*, Proceedings of the IEEE, no. 2, vol. 92, 2004, pp. 198-216.
2. H. Bolcskei, A.J. Paulraj, *Multiple-Input Multiple-Output (MIMO) Wireless Systems*, in book *The Communications Handbook* edited by J. D. Gibson, CRC Press, 2002.
3. W. Dziunikowski, W. Ludwin, *Układy antenowe MIMO w sieciach bezprzewodowych*, Przegląd Telekomunikacyjny, nr 5, 2003.
4. R.J. Katulski, M. Mikołajski, *Technika zwielokrotnionego nadawania i zbiorczego odbioru w telekomunikacji bezprzewodowej*, Przegląd Telekomunikacyjny, nr 2-3, 2005.
5. H. Liu, L. Guoqing, *OFDM-Based Broadband Wireless Networks*, John Wiley & Sons, 2005.
6. D. Gesbert, M. Shafi, et al., *From Theory to Practice: An Overview of MIMO Space-Time Coded Wireless Systems*, IEEE Journal On Selected Areas In Communications, vol. 21, no. 3, pp. 281-302, 2003.
7. K. Wesołowski, *Systemy wielowejściowe/wielowyjściowe (MIMO) w radiokomunikacji ruchomej*, Przegląd Telekomunikacyjny, nr 6, 2004.
8. B. Holter, *On the Capacity of the MIMO Channel – A Tutorial Introduction*, [http://www.iet.ntnu.no/projects/beats/Documents/MIMO\\_introduction.pdf](http://www.iet.ntnu.no/projects/beats/Documents/MIMO_introduction.pdf).
9. G.J. Foschini, D. Chizhik, et al., *Analysis and Performance of Some Basic Space-Time Architectures*, IEEE Journal on Selected Areas in Communications, vol. 21, no. 3, pp. 303-320, 2003.
10. G.J. Foschini, *Layered Space-Time Architecture for Wireless Communication in Fading Environment when Using Multi-Element Antennas*, Bell Labs Technical Journal, vol. 2, 1996.
11. D. Shiu, J.M. Kahn, *Layered Space Time Codes for Wireless Communications using Multiple Antennas*, IEEE International Conference on Communications, vol. 1, pp. 436-440, 1999.
12. P.W. Wolniansky, et al., *V-BLAST: An Architecture for Realizing Very High Data Rates Over the Rich-Scattering Wireless Channel*, Proc. ISSSE-98, Pisa, Italy, 1998.
13. G.D. Golden, et al., *Detection algorithm and Initial Laboratory Results Using V-BLAST Space-Time Communication Architecture*, Electronics Letter, vol. 35, no. 1, pp. 14-15, 1999.
14. V. Tarokh, et al., *Space-Time Codes for High Data Rate Wireless Communication: Performance Criterion and Code Construction*, IEEE Transactions on Information Theory, vol. 44, no. 2, pp. 744-765, 1998.
15. A. Hottinen, *Multi-antenna Transceiver Techniques for 3G and Beyond*, John Wiley & Sons, 2003.
16. V. Tarokh, et al., *Space-Time Block Codes from Orthogonal Designs*, IEEE Transactions on Information Theory, vol. 45, no. 5, pp. 1456-1467, 1999.
17. S.M. Alamouti, *A Simple Transmit Diversity Technique for Wireless Communications*, IEEE Journal on Selected Areas in Communications, vol. 16, no. 8, pp.1451-1458, 1998.