

ANALYSIS OF THE ENVIRONMENTAL IMPACT OF THE HULL CONSTRUCTION OF A SMALL VESSEL BASED ON LCA

Jacek Nakielski 

Gdansk University of Technology, Institute of Naval Architecture, Poland

* Corresponding author: janak@pg.edu.pl (J.Nakielski)

ABSTRACT

In recent years, issues related to the impact of human activity on the natural environment have become pressing, and the challenge of global warming necessitates immediate action. To support environmental protection efforts, it has become imperative to adopt a broader perspective when evaluating various products and systems. A valuable tool for such assessments is a life cycle assessment (LCA), which enables a comprehensive analysis of the entire life cycle of a product.

This paper presents a comparative analysis of the hull of a fast patrol craft, fabricated using three different materials: steel, aluminium, and composite materials. The LCA covers every stage from material production, through the construction and use of the hull, to its eventual disposal. A specific criterion was established to evaluate the impact of the hull on the environment, with clearly defined system boundaries.

In the final section, we draw some conclusions that underscore the importance of reusing construction materials. By emphasising this approach, ecological footprints can be minimised and a sustainable future can be created.

Keywords: LCA, hull, craft, recycling materials

INTRODUCTION

Over the past few decades, there has been a substantial increase in awareness of ecological issues and the urgent need for environmental protection. This heightened awareness has primarily been driven by the alarming surge in greenhouse gas emissions, which significantly contribute to Earth's changing climate [1]. Numerous actions are now being carried out to address this critical situation, including changes in approaches to natural resources, production processes, and the exploitation, disposal and recycling of materials.

To evaluate the environmental impact of a given product, the life cycle assessment (LCA) has emerged as a valuable method. This structured approach, which has been standardised by the ISO (International Organization for Standardization) [26], enables

a comprehensive evaluation of the inputs and outputs of a product's environmental impact over its entire life cycle. An LCA typically has four main components: goal definition and boundary setting, analysis, impact assessment, and interpretation [3].

Due to the inherent complexity of a ship, conducting a thorough analysis is particularly challenging, and this especially true when interpreting the results. To streamline and enhance the effectiveness of the LCA method, it is advisable to break down the ship into subsystems (hull, engine room, equipment, etc.). A crucial aspect of this process is the selection of appropriate system boundaries, as this can significantly influence the outcomes and their subsequent interpretation [4].

In this paper, an analysis using LCA and life cycle cost analysis (LCCA) is applied to a luxury mono-hull motor yacht [5]. Four design configurations of the hull are considered, and it is shown

that the lowest total life cycle cost is found for a configuration with an aluminium hull and carbon fibre composite hatches.

In a study by Wang et al. [6], an analysis based on an LCA was carried out for a hybrid ferry. LCA models were established using commercial software called GaBi (a portmanteau of two German words, Ganzheitliche Bilanzierung), and included various activities associated with the four phases of the ship's life, including steel processing and machinery installations in the shipyard; the operation of the engine and batteries on board; maintenance of the ship hull; and the scrapping of hull materials and machinery. Among other things, these authors presented an optimal strategy for coating of the hull.

For a better understanding of the LCA methodology, the reader is referred to [7]. This paper presents several examples of decisions made based on the LCA methodology; for example, the decision as to whether the hull of the new Greenpeace flagship "Rainbow Warrior III" was to be built from steel or aluminium was made by the Dutch company TNO.35 using the LCA methodology. Based on the results from the LCA, steel was chosen for the hull, while the superstructure and mast were built from aluminium.

METHOD

ENVIRONMENTAL IMPACT ASSESSMENT CATEGORY FOR THE HULL

When assessing the environmental impact of a particular object, the first step is to determine the factors that will define this impact. Today, one of the most widely used criterion for evaluation is the carbon footprint, which represents the total greenhouse gas emissions resulting from the production, operation, and disposal of the hull of a craft. Alternatively, the water footprint or the overall environmental footprint can be considered. In this article, however, energy consumption serves as the chosen category for evaluating the object's environmental impact.

Data on the energy consumption of various technological processes can be found in a diverse range of literature sources. Although the appropriateness of using energy as an environmental impact criterion is subject to debate, we note that energy exhibits a lower variability compared to other physical flows. This enhances its reliability as a measure for assessing the environmental influence of an object.

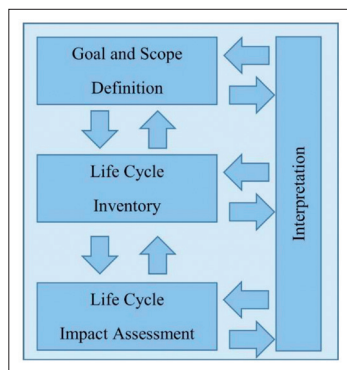

Fig. 1. Phases of an LCA according to ISO 14040:2006 Environmental management—Life cycle assessment—Principles and framework [2]

STUDY OBJECT

The hull of the fast patrol craft described in [8] was chosen as a subject for further analysis. The primary objective was to find the optimal shape of the hull for several different materials. Table 1 provides an overview of the fundamental parameters of the unit, while Figs. 2 and 3 present visual representations of hulls made of aluminium and composite (fibre-epoxy laminate), respectively.

For this study, three materials were considered for the hull: steel, aluminium, and glass-epoxy laminate. Of the characteristic parameters examined here, one of the key factors was the weight of the hull for each material, as shown in Table 2.

Tab. 1. Specifications of the 24 m high-speed patrol craft studied in this paper [8]

Basic parameter	Value	Units
Overall length	23.85	m
Length between perpendiculars	20.05	m
Overall breadth	5.10	m
Draft design waterline	0.97	m
Loaded displacement	48.20	tons
Light displacement	38.20	tons
Total power installed	1380	kW

Table 2 shows the weights of the hull when made of different materials.

Tab. 2. Mass of the hull of the 24 m high-speed patrol craft [8]

Material	Mass [kg]
Steel (NV40)	16,700
Aluminium (NV-5083)	8,700
Composite (fibre-reinforced epoxy)	7,700

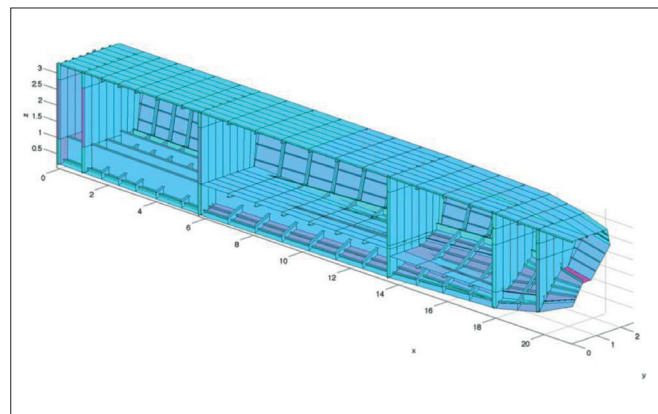

Fig. 2. Structure of the aluminium hull [8]

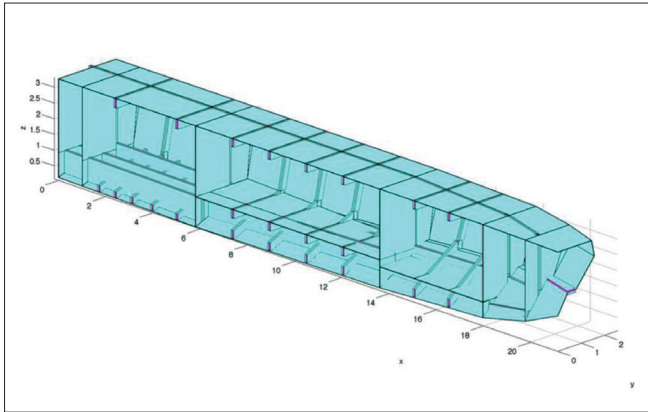

Fig. 3. Structure of the composite hull [8]

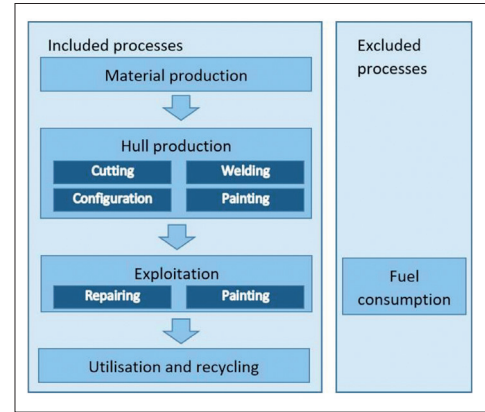

Fig. 4. Boundaries of the system [2]

BOUNDARIES OF THE SYSTEM

To conduct a comprehensive analysis based on LCA, it is vital to establish clear boundaries and definitions. In the analysis presented below, the boundaries have been precisely defined as follows [9]:

1. A „cradle-to-grave” approach is applied that considers the entire life cycle of the hull, encompassing the production of materials required for its construction, its operational phase (lasting 20 years), eventual disposal, and the potential for material reuse.
2. Characteristics of the hull that remain constant and do not vary depending on the material used have been excluded from the analysis.
3. The assumption is made that all materials and processes examined here are exclusively used to construct the hull, and are not employed elsewhere.
4. Fuel consumption has been excluded from the analysis, given that a lighter hull generally leads to reduced fuel consumption or requires a less powerful engine for propulsion.
5. The production of tools and other materials essential for the construction of the hull is not considered in this study.

Clearly defining these boundaries allows the analysis to be focused and relevant, and permits a more accurate evaluation of the hull’s environmental impact based on the selected criteria. The boundaries of the system are illustrated in Fig. 4.

RESULTS

PRIMARY PRODUCTION OF MATERIALS

To determine the energy consumption over the entire life cycle of the hull, the initial step is to calculate the energy consumed in the production of each individual material. This analysis includes the primary production of the material, starting from the extraction procedure, and all necessary technological processes; the energy needed to obtain materials from recycling is also considered.

Table 3 presents a comprehensive summary of the results for the energy consumption during production of the materials used to construct the hull of the craft. These findings serve as a basis for a further evaluation of the hull’s environmental impact using the LCA approach.

From the table above, it can be seen that the production of aluminium is the most energy-intensive process among the materials considered here: for instance, the energy consumption associated with the recycling of aluminium is comparable to the primary production of steel. However, for the construction of the same hull, approximately twice as much steel is needed compared to aluminium. The production of composite materials is also a highly energy-intensive process.

Tab. 3. Total energy required to produce the hull material [4], [10], [11], [12]

Process	Mass	Units	SEC	Units	Energy consumption	Unit
Steel production (primary steel)	16,700	kg	22.00	MJ/kg	367,400	MJ
Steel production (recycled steel)	16,700	kg	8.60	MJ/kg	143,620	MJ
Aluminium production (primary aluminium)	8,700	kg	220.0	MJ/kg	1,914,000	MJ
Aluminium production (recycled aluminium)	8,700	kg	20.0	MJ/kg	174,000	MJ
Production of glass-epoxy laminate	7,700	kg	70.0	MJ/kg	539,000	MJ
Production of glass-epoxy laminate						

Tab. 4. Energy consumed in the production of the steel hull

Process	Mass	Units	SEC	Units	Energy consumption	Unit
Cutting with an oxy-acetylene torch	262.00	m	0.25	MJ/m	65.50	MJ
MAG welding of transverse stiffeners	821.00	m	4.70	MJ/m	3,858.70	MJ
MAG welding of longitudinal stiffeners	821.00	m	5.50	MJ/m	4,515.50	MJ
MAG welding hull and deck plating	262.00	m	3.00	MJ/m	786.00	MJ
Painting – wetted surface area of the hull	148.00	m ²	38.00	MJ/m ²	5,624.00	MJ
Painting – unwetted surface area of the hull	77.84	m ²	25.00	MJ/m ²	1,946.00	MJ
Painting – deck area	99.74	m ²	25.00	MJ/m ²	2,493.50	MJ
Painting – surface of the inner part of the hull	508.71	m ²	10.00	MJ/m ²	5 087.6	MJ
Total:					24,493.50	MJ
SEC - specific energy consumption						

Tab. 5. Energy consumed in the production of the aluminium hull

Process	Mass	Units	SEC	Units	Energy consumption	Unit
Water jet cutting	262.00	m	0.06	MJ/m	15.72	MJ
Friction stir welding – longitudinal stiffeners	630.00	m	1.20	MJ/m	756.00	MJ
Friction stir welding – transverse stiffeners	260.00	m	1.20	MJ/m	312.00	MJ
Friction stir welding – hull and deck plating	262.00	m	1.20	MJ/m	314.00	MJ
Painting – wetted surface area of the hull x	148.00	m ²	28.00	MJ/m ²	4,144.00	MJ
Painting – unwetted surface area of the hull x	77.84	m ²	15.00	MJ/m ²	1,167.60	MJ
Painting – deck area	99.74	m ²	15.00	MJ/m ²	1,496.10	MJ
Painting – surface of the inner part of the hull	554.95	m ²	10.00	MJ/m ²	5,549.52	MJ
Total:					13,755.34	MJ
SEC - specific energy consumption						

Tab. 6. Energy consumed in the production of the composite hull

Process	Mass	Units	SEC	Units	Energy consumption	Unit
Plug	213.00	m ²	51.00	MJ/m ²	10,863.00	MJ
Steel supporting structure	213.00	m ²	10.00	MJ/m ²	2,130.00	MJ
Vacuum infusion process	213.00	m ²	7.00	MJ/m ²	1,491.00	MJ
Curing	213.00	m ²	430.00	MJ/m ²	91,590.00	MJ
Painting – wetted surface area of the hull	148.00	m ²	28.00	MJ/m ²	4,144.00	MJ
Painting – unwetted surface area of the hull	77.84	m ²	15.00	MJ/m ²	1,167.60	MJ
Painting – deck area	99.74	m ²	15.00	MJ/m ²	1,496.10	MJ
Painting – surface of the inner part of the hull	485.58	m ²	10.00	MJ/m ²	5,855.83	MJ
Total:					117,737.53	MJ
SEC - specific energy consumption						

HULL CONSTRUCTION

To estimate the energy costs associated with the construction of the hull, including processes such as cutting, welding, vacuum infusion, hardening, and painting, specific parameters needed to be calculated, such as the weld lengths, mould surfaces, and surfaces to be painted. These calculations and estimates were made based on data from references [8] and [13].

We note that when constructing a hull using primary or recycled steel, the energy costs remain constant. Similarly, for an aluminium hull, the energy consumed during the production process is unchanged regardless of whether the aluminium used for production is from primary or recycled sources.

Table 4 summarises the individual processes related to the production of the steel hull.

A very similar combination of individual postproduction processes are also found for the construction of the aluminium hull (see Table 5).

The production technology used for the composite hull differs significantly from the steel and aluminium hulls. An important step in the production of the composite hull is the implementation of a „plug” used as the basis for the lamination process. For serial production, the plug can be reused, leading to reduced energy expenditure; however, for the purposes of this article, unit production is assumed.

The results for the energy balance for the entire production process, including material production and hull construction, are interesting. For primary steel, the hull construction process accounts for only 6.63% of the overall energy consumption at this stage, whereas for an aluminium hull, this value is only 0.72%. When the materials are obtained from recycling, these values rise to 39.09% for steel and 9.09% for aluminium. In contrast, for a hull made using composite technology, the percentage is 21.84%. Fig. 5 shows a graph of these values.

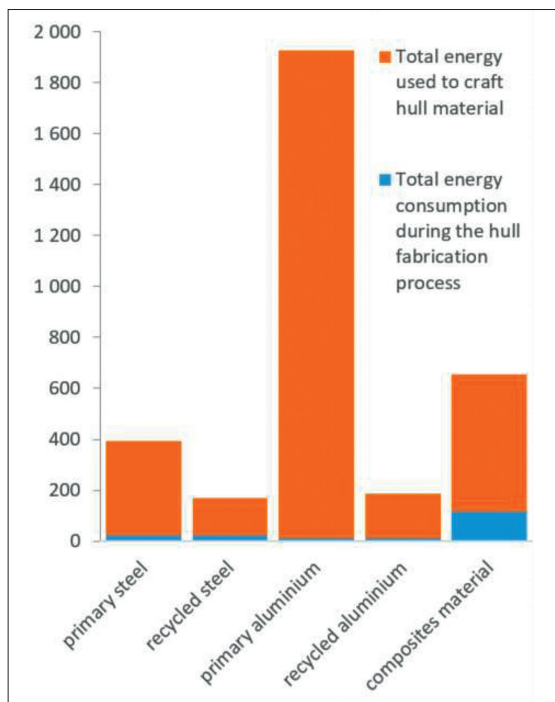

Fig. 5. Total energy consumed in producing the hull material and fabricating the hull

HULL USE

The next stage in the life cycle of the hull is its usage. In the scenario considered here, we assume that each year, 10% of the material of the hull will be replaced, regardless of the material or technology used for construction. Although other scenarios could be considered, we adopt a simplified approach for the sake of this analysis. In addition, we assume that the life expectancy of each hull is 20 years, though this assumption may be subject to question, as hulls often remain in service beyond two decades. The replacement process itself, together with the energy consumed during the production of the replacement material, makes up 10% of the energy required for the production of the original hull (in the case of the composite material hulls, energy costs related to the production of the plug are not included).

Another factor related to hull usage is maintenance, which mainly involves painting. Steel hulls are repainted every five years, while those made of other materials require annual repainting.

Table 7 provides a comprehensive overview of each type of hulls and the individual energy costs during use.

Tab. 7. Energy consumed during use

Process	Energy consumption	Units
Primary steel		
Total energy used to craft hull material	36,740.00	MJ
Total energy consumed in the hull fabrication process	922.57	MJ
Painting (every five years)	15,150.56	MJ
Total over 20 years	813,853.64	MJ
Secondary steel		
Total energy used to craft hull material	14,362.00	MJ
Total energy consumed in the hull fabrication process	922.57	MJ
Painting (every five years)	15,150.56	MJ
Total over 20 years	366,293.64	MJ
Primary aluminium		
Total energy used to craft hull material	191,400.00	MJ
Total energy consumed in the hull fabrication process	139.81	MJ
Painting (every year)	12,357.22	MJ
Total over 20 years	1,927,755.34	MJ
Secondary aluminium		
Total energy used to craft hull material	17,400.00	MJ
Total energy consumed in the hull fabrication process	139.81	MJ
Painting (every year)	12,357.22	MJ
Total over 20 years	597,940.64	MJ
Composite material		
Total energy used to craft hull material	52,813.70	MJ
Total energy consumed in the hull fabrication process	10,607.40	MJ
Painting (every year)	11,663.53	MJ
Total over 20 years	1,501,692.60	MJ

RECYCLING AND DISPOSAL

When considering the life cycle of the hull for a selected craft, the final element is disposal, as steel and aluminium hulls can be recycled. The disposal process involves cutting or dismembering the hull, which naturally consumes energy. However, steel and aluminium offer extensive possibilities for reuse, with up to 95% of the hull weight being recyclable according to [5]. In contrast,

Tab. 8. Recycling and disposal

Process	Mass	Units	SEC	Units	Energy consumption	Unit
Steel						
Cutting with an oxy-acetylene torch	846.00	m	0.25	MJ/m	211.50	MJ
Reuse of steel					-212 591.00	MJ
Total:					-212 379.50	MJ
Aluminium						
Plasma cutting	846.00	m	0.86	MJ/m	727.56	MJ
Reuse of aluminium					-1 653 000.00	MJ
Total:					-1 652 272.44	MJ
Composite material						
Shredding	7,700.00	kg	0.92	MJ/kg	7,084.00	MJ
Burning	770.00	kg	30.00	MJ/kg	-23,100.00	MJ
Total:					-16,016.00	MJ
SEC - specific energy consumption						

only 5% of a composite hull can be recycled [5]. Research is under way to improve the recycling possibilities for composite materials [14, 15].

DISCUSSION

Table 9 and Fig. 6 show the total energy consumption for each type of material considered here. For recycled steel and aluminium, the environmental benefits from their reuse were not taken into account.

Tab. 9. Total energy consumption

Primary steel	Recycled steel	Primary aluminium	Primary aluminium	Composite material
993.25 GJ	534.50 GJ	4,353.42 GJ	786.42 GJ	2,142.41 GJ

The data show that building a hull from primary aluminium incurs the highest energy consumption, followed by a hull made of composite materials. The use of recycled materials significantly reduces the energy consumption, and this is particularly noticeable for aluminium. Although steel hulls are the heaviest, steel is found to be the most energy-efficient material. The energy cost for primary steel is only about 200 GJ higher than that of recycled aluminium. The difference in energy cost between primary and recycled aluminium is considerable, whereas the difference between virgin and recycled steel is relatively smaller. A hull made of recycled steel is 1.86 times less energy-consuming than a hull made of virgin steel; in contrast, the ratio for aluminium is 5.34.

Composite materials are relatively inefficient in terms of energy consumption, as the recycling of these materials is challenging. Intensive research is ongoing to make the recycling of composite materials more efficient.

CONCLUSION

In this study, a relatively simple model was considered with similar life cycle scenarios for hulls made of different materials. In future analyses, the life cycle scenarios for specific materials

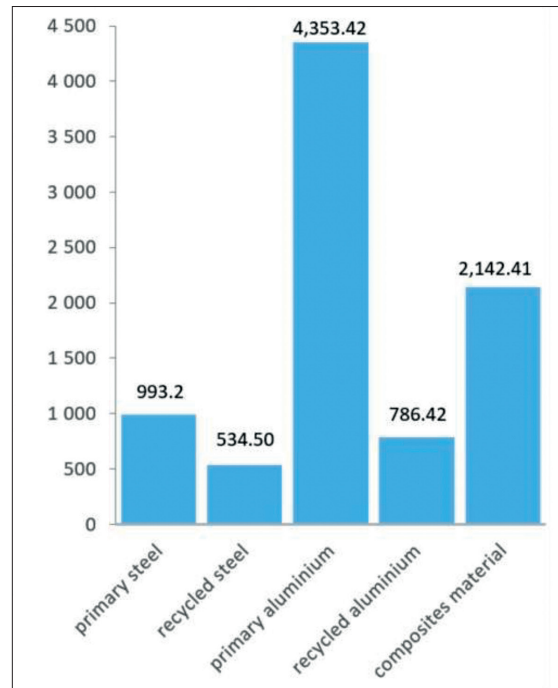

Fig. 6. Total energy consumption

may be calculated with greater precision.

Technological processes such as welding or gas cutting, which are based on electrical or chemical energy, are less energy-efficient than processes based on mechanical energy, such as welding and water jet cutting.

The analysis of the hull production focused on the processes themselves (cutting, welding, painting). However, the overall energy required to make the hull is higher than that considered here, because our analysis did not take into account factors such as transport, water consumption, electricity needed for lighting and ventilation, etc. A comparison of the ratio of the energy used in the production of the hull to the energy needed to produce the material (0.72% for aluminium, 6.63% for steel) need not take this additional energy into account, but in future

research, the total energy cost of hull production, especially for recycled and composite materials, could be calculated to give more accurate results.

The production stage of the individual materials incurred the highest energy cost, meaning that the development of technologies to reduce energy consumption during production processes is crucial. It is also important to ensure that the energy used in the production of steel or aluminium comes from renewable sources.

The choice of hull material significantly influences both the energy costs and the environmental footprint. Analyses such as the one presented here can aid in making informed decisions at the design stage.

One key element of a strategy for reducing the cost of energy consumption, and hence the impact on the environment, is the reuse of materials. In the case considered here, this was particularly applicable to aluminium.

REFERENCES

1. J. Barreiro, S. Zaragoza, and V. Diaz-Casas, 'Review of ship energy efficiency', *Ocean Engineering*, Volume 257, 2022. doi: 10.1016/j.oceaneng.2022.111594.
2. ISO 14040:2006 Environmental management - Life cycle assessment - Principles and framework.
3. S.D. Chatzinikolaou and N.P. Ventikos, 'Assessing environmental impacts of ships from a life cycle perspective', in *2nd International Conference on Maritime Technology and Engineering, MARTECH 2014*, Lisbon, Portugal, 15-17 October 2014. doi.org/10.1201/b17494
4. L. Joosten, 'The Industrial Metabolism of Plastics. Analysis of Material Flows, Energy Consumption and CO₂ Emissions in the Lifecycle of Plastics', PhD [Dissertation], Utrecht University, 2001.
5. C. Favi, M. Germani, F. Campi, M. Mandolini, S. Manieri, M. Marconi, and A. Vita, 'Life cycle model and metrics in shipbuilding: How to use them in the preliminary design phases', in *25th CIRP Life Cycle Engineering (LCE) Conference*, Copenhagen, Denmark, 30 April – 2 May 2018. doi: 10.1016/j.procir.2017.11.071
6. H. Wang, E. Oguz, B. Jeong, and P. Zhou, 'Life cycle cost and environmental impact analysis of ship hull maintenance strategies for a short route hybrid ferry', *Ocean Engineering*, Volume 161, Pages 20-28, 2018. doi: 10.1016/j.oceaneng.2018.04.084
7. T. Pawlik, Ed., 'Ship life cycle assessment and management', City University of Applied Sciences and GAUSS GmbH, Bremen, Germany, 2011.
8. I. Stenius, A. Rosén, and J. Kutteneuler, 'On structural design of energy efficient small high-speed craft', KTH Centre for Naval Architecture, *Marine Structures*, Volume 24(1): Pages 43-59, 2010. doi: 0.1016/j.marstruc.2011.01.001
9. P. Borowiec, 'Life cycle assessment for selected vessel', MSc [Dissertation], Gdansk University of Technology, 2022.
10. S. V. Joshi, L. T. Drzal, A. K. Mohanty, and S. Arora, 'Are natural fiber composites environmentally superior to glass fiber reinforced composites?', *Composites Part A: Applied Science and Manufacturing*, Volume 35, Issue 3, Pages 371-376, 2004. doi: 10.1016/j.compositesa.2003.09.016
11. P. Michaelis, T. Jackson, and R. Clift, 'Exergy analysis of the life cycle of steel', *Energy* Volume 23, Issue 3, Pages 213-220, 1998. doi: 10.1016/S0360-5442(97)00081-9
12. G. Rombach and D. Liebig, 'A scenario to optimise the energy demand of aluminium production depending on the recycling quota', *Resources, Conservation and Recycling*, Volume 33, Issue 3, Pages 217-234, 2001. doi: 10.1016/S0921-3449(01)00086-6.
13. F. Nicolae, C. Popa, and H. Beizadea, 'Applications of life cycle assessment (LCA) in shipping industry', *14th International Multidisciplinary Scientific GeoConference & EXPO SGEM2014, Section Air Pollution and Climate Change*, Albena, Bulgaria, 17-26 Jun 2014. doi: 10.5593/sgem2014/b42/s19.038.
14. Jianqiao Wu, Ying Pan, Ziyi Ruan, Ziji Zhao, Jing Ai, Jinghai Ban, and Xianghai Jing, 'Carbon fiber-reinforced epoxy with 100% fiber recycling by transesterification reactions', *Frontiers in Materials Sec. Polymeric and Composite Materials*, Volume 9, 2022. doi: 10.3389/fmats.2022.1045372.
15. M. M. Rabby, M. Rahman, P. P. Das, V. Vadlamudi and R. Rassel, 'Carbon fibers recycling from degraded prepress and mechanical properties of recycled composite', *North America Society for the Advancement of Material and Process Engineering (SAMPE)*, Seattle, United States, 17 April 2023. doi: 10.33599/nasampe/s.23.0267.