

APPLICATION OF OFDM TECHNIQUE TO UNDERWATER ACOUSTIC DATA TRANSMISSION¹

IWONA KOCHAŃSKA, HENRYK LASOTA

Gdansk University of Technology
11/12, G. Narutowicza St., 80-233 Gdańsk, Poland
ia.kochanska@gmail.com; hlas@eti.pg.gda.pl

Performances of underwater acoustic communication (UAC) digital systems are strongly related to specific transmission properties of the underwater channel. Depending on the characteristics of the channel, an architecture and modulation techniques are usually implemented that are known as reliable solutions for data transmission in difficult radio channels. The OFDM technique seems to be the most promising nowadays. The parameters of the physical layer and data link layer of ISO/OSI model are adapted to the needs of underwater communications, so as to best protect the signal from distortions and interferences typical for the underwater environment. This paper compares the performance of UAC and wireless telecommunications systems working in channels of vary different transmission parameters. Based on these parameters, some physical and link layer configurations of OFDM data transmission systems are proposed for implementation in a laboratory model and testing at a lake.

INTRODUCTION

Data transmission rates in underwater acoustic communication (UAC) systems are much lower than available in wireless communications. The reason is not only that the carrier frequency range of ultrasonic signals is situated much lower than radio frequencies, resulting in proportionally lower effective bandwidth - here some progress can be expected from the technology of broadband transducers for acoustic antennae; even more disadvantageous is the influence of communication properties ultrasound meets in inland and sea waters.

Due to the large variability of properties of underwater communication channels, mostly classified as shallow underwater acoustic (SUWA) channels, there is a need for adaptive matching of the UAC systems communication signaling to instantaneous, often strongly varying, channel conditions. Without optimizing signal parameters in both physical and link

¹ Supported by a grant from the Ministry of Science and Higher Education, decision 4706/B/T02/2011/40.

layers of communication protocols, a communication system would be forced to work with settings assuming the worst possible conditions; this would strongly limit its effective bandwidth, range, speed and efficiency.

Adaptation of modulation and coding techniques, known from wireless telecommunication systems, to the properties of the channel should significantly improve the quality of communication.

1. OFDM TECHNIQUE

Among the designers of underwater communication systems, considerable interest in the so-called orthogonal frequency division multiplexing (OFDM) technique is observed [1, 2]. OFDM is a technique of particular interest to groups developing contemporary wireless communications standards. OFDM is a spectrally efficient and ISI-resistant modulation and coding technique, commonly used in wide-band ADSL telecommunication modems. Its flexibility allows to match the transmitted signal parameters to the current conditions in the communication channel.

Matching signal parameters to the channel conditions requires knowledge of the characteristics of the channel. Time-varying impulse response can be measured at the beginning of communication, during the connection establishing procedure, known as a handshake, which checks the link and allows the channel to be tested in operation.

The adaptation of OFDM technique to ultrasound underwater communication requires assumption of a flexible channel model, which is a statistical model with assumption of wide sense stationarity of channel characteristics (WSS) and uncorrelated scattering (US) of multipath components arriving to the communication system receiver. Statistical parameters resulting from the instantaneous impulse response measurements and the adopted channel model are essential for transmitted signal parameters calculation [3].

The chosen design methodology of OFDM modems transmission protocol, including handshake, for underwater communication is based on comparing the physical limitations of radio and underwater channels. Analysis of the UAC communication conditions in terms of the radio OFDM systems channels determines the physical layer parameters, such as the OFDM symbol duration, length of cyclic prefix, and subcarriers spacing.

OFDM is a technique of particular interest of contemporary radio standards. The idea of orthogonal frequency division multiplexing is a digital multi-carrier modulation method. It is based on splitting a high-speed broadband transmission into many slower narrow-band transmissions (Fig. 1). A large number of closely-spaced orthogonal sub-carriers are used to carry data. OFDM modulator diagram is shown in Fig. 2.

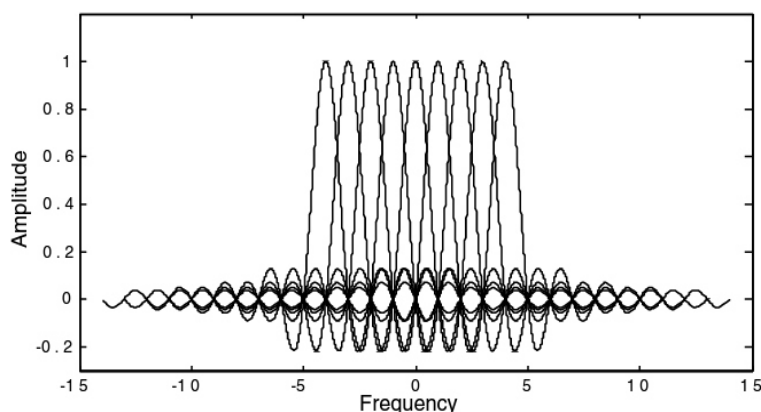

Fig. 1. OFDM signal spectrum [1]

The data is split into several parallel data streams, one for each sub-carrier. Each sub-carrier is modulated with a conventional modulation scheme (such as QAM, PSK or DPSK technique) at a low symbol rate, maintaining total data rates similar to conventional single-carrier modulation schemes in the same bandwidth. Streams of complex constellation symbols are next processed by the inverse Fourier transform, forming a sequence of complex OFDM waveform samples. Then the sequence is converted into an analog signal, which modulates in quadrature the carrier of center frequency of OFDM signal spectrum. Bandwidth B of OFDM modulated signal is the sum of adjacent subchannels, each of bandwidth W . Time duration of a single OFDM symbol is $T_s = 1/W$.

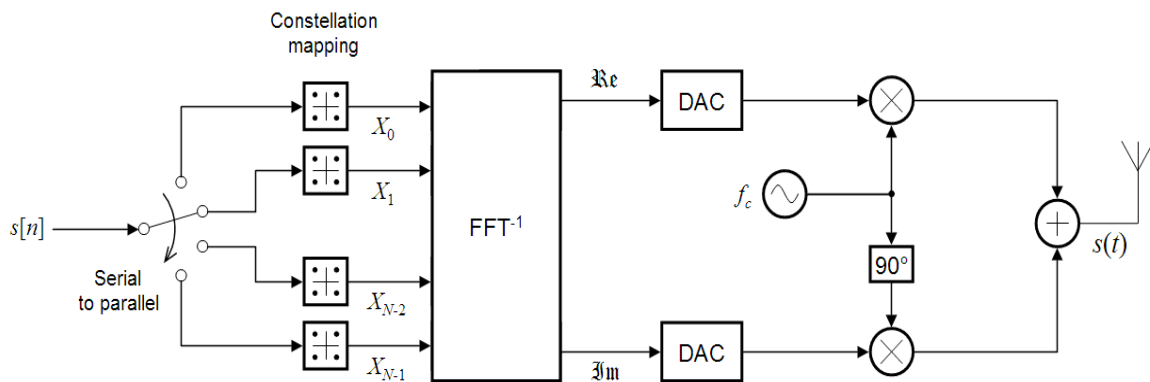

Fig. 2. OFDM modulator scheme [4]

Each OFDM symbol is preceded by a cyclic prefix, i.e. a redundant repetition of the last segment of itself (Fig. 3). Cyclic prefix of duration T_G protects the OFDM signal against intersymbol interferences.

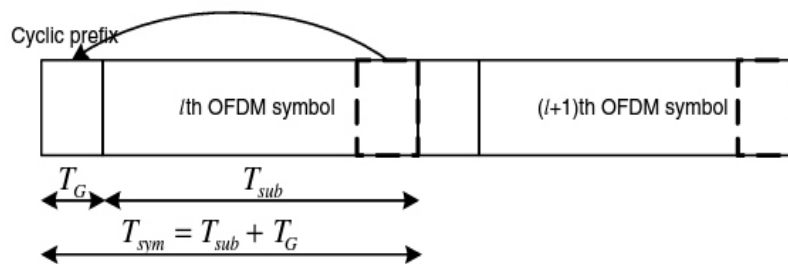

Fig. 3. OFDM symbol with cyclic prefix [1]

Values of OFDM parameters are determined on the basis of the telecommunications requirements of desired transmission bit rate and the characteristics of the communication channel.

2. COMPARISON OF WIRELESS AND UAC OFDM SYSTEMS

Table 1 presents the comparison of data transmission characteristics of: (1) wireless local area networks (WLAN) [5], (2) the so-called long term evolution (LTE) cellular networks [6–8], and (3) a hypothetical UAC system designed on the basis of transmission properties of shallow underwater channel measured in natural conditions of a river SUWA channel as described in [9].

Whereas Doppler spread in radio channels is in the order of 10^{-5} to 10^{-6} of the system bandwidth, in a shallow underwater acoustic channel it is in the order of 10^{-3} of the bandwidth.

Expected data rates in UAC system designed based on measurements in [9] does not exceed a few kilobits per second. Higher data rates are reported in cases of underwater MIMO OFDM systems using multiple transmitters and receivers [2, 10].

Table 1. Channel parameters of OFDM systems

channel conditions	WLAN	LTE	UAC
propagation velocity	$3 \cdot 10^8$ m/s	$3 \cdot 10^8$ m/s	1500 m/s
carrier frequency f_c	2.4 GHz	2.5 GHz	10 kHz
max movement velocity	2 m/s	36 m/s	2 m/s
rms excess delay τ_{rms}	100 μ s	1 ms	149 μ s
coherence time Δt_c	26 ms	1.4 μ s	50 ms
Doppler spread f_m	16 Hz ($\approx 0.0001\%$ B)	300 Hz ($\approx 0.0015\%$ B)	3 Hz ($\approx 0.15\%$ B)
coherence bandwidth Δf_c	20 MHz	200 kHz	2.2 kHz
system bandwidth B	17 MHz	1.4, 3, 5, 10, 15, 20 MHz	2 kHz

Table 2. Performances of OFDM systems

system parameters	WLAN	LTE	UAC
OFDM symbol duration T_S	4 μ s (= 400 τ_{rms} , $\Delta t_c/6500$)	71.4 μ s ($\approx 72 \tau_{rms}$, $\Delta t_c/20$)	12.5 ms ($\approx 84 \tau_{rms}$, $\Delta t_c/4$)
OFDM subchannel bandwidth	312.5 kHz ($\approx 20000 f_m$, $\Delta f_c/64$)	15 kHz ($\approx 50 f_m$, $\Delta f_c/13$)	100 kHz ($\approx 34 f_m$, $\Delta f_c/22$)
number subcarriers	52	72, 180, 300, 600, 900, 1200	20
cyclic prefix T_G	800 ns	4.7 μ s	2.5 ms
modulation	BPSK, QPSK, 16-QAM, 64-QAM	QPSK, 16-QAM, 64-QAM	BPSK, QPSK, 16-QAM
coding rate	1/2, 2/3, 3/4	1/3-1	1/2, 2/3, 3/4
data rate	6, 9, 12, 18, 24, 36, 48, 54 Mbps	100 Mbps	0.4 – 3.6 kbps

3. PHYSICAL AND LINK LAYERS REQUIREMENTS

There is no ‘typical’ underwater communication channel [9]. Each environment has different characteristics that affect the behavior of a digital communication system. However, there are classes of underwater communication channels and it is possible to design the architecture of physical and link layers of ISO/OSI transmission system model, so as to operate in a satisfactory manner within the class.

In the physical layer, the channel is understood through the theory of acoustic wave propagation, its limitations and the measurement of impulse response. Knowledge of basic limitations of signaling in an underwater environment translates into increasingly sophisticated digital communication techniques, tailored to the unique characteristics of the UAC channel. Solutions adapted to the UAC systems must have good adaptive and synchronization properties - so they have to meet the upper range of the radio communication requirements.

In the link layer of transmission, protocol packets of data are constructed so as to be well suited to meeting the constraints of half-duplex modems, limited bandwidth and variable

quality of service. In a particularly tough channel, reliability is enhanced through the implementation of selective automatic repeat requests technique (selective ARQ).

Based on the underwater communication system requirements, measured channel characteristics and WSS-US channel model, OFDM parameters are determined as follows [3]:

1. Total bandwidth of OFDM signal should cover the entire range of available frequencies for data transmission, determined by the bandwidth of transducer.
2. The orthogonality of carrier frequencies is provided by the IFFT algorithm applied in UAC system transceiver.
3. The coherence bandwidth Δf_c sets an upper limit on a single OFDM subchannel bandwidth (the signaling rate W). The bandwidth of single OFDM channel should be much larger than the Doppler spread f_m :

$$\Delta f_c > W \gg f_m \quad (1)$$

4. The rms excess delay τ_{rms} (or maximum excess delay τ_{max}) sets an upper limit on the OFDM symbol duration. Also, the OFDM symbol should be much longer than the channel coherence time Δt_c :

$$\Delta t_c \ll T_s < \tau_{rms} \quad (2)$$

5. Extending the OFDM symbol by using the cyclic prefix, which is a kind of redundancy, is associated with loss of signal to noise ratio. It is desirable to reduce to a minimum the throughput loss of SNR; therefore a symbol period five to six times larger than the cyclic prefix period should be chosen, which results in less than 1-dB loss in throughput [11].

4. HANDSAKE PROTOCOL FOR UAC OFDM SYSTEM

Data transmission is followed by a handshake consisting of two phases (Fig. 4). During the first phase the channel impulse response is measured using the MLS sequence. Good synchronization and correlation properties of the received MLS signal allow the system 'recipient' to detect the beginning of signal transmission and measure the time-varying impulse response of the channel.

Measured impulse response is analyzed and the functions and parameters of WSS-US channel model are estimated. Next, estimated parameters are modulated by spread spectrum technique by convolving data with MLS sequence, and sent through the control channel to the 'sender' of communication system.

During the handshake second phase the 'sender' calculates OFDM modulation parameters based on received information about WSS-US model estimates. Next, the testing signal is formed and sequence of OFDM symbols, followed by synchronization MLS sequence, is sent to the 'recipient'. Based on received testing signal the bit error rate for each OFDM subchannel is calculated and the decision is made if BER for given subchannel is acceptable. Information about useful subchannels indices, modulated with spread spectrum technique, is sent back to the 'sender'.

Data transmission is performed only at the subchannels indicated by the 'recipient' as useful. Each packet of OFDM symbols is followed by a synchronization MLS sequence. A few of the OFDM subchannels are used as pilot tones to compensate for phase distortions, caused by the channel influence and the difference between sampling frequencies of the 'sender' and the 'recipient' sound devices.

In the case of particularly tough communication conditions, it may be necessary to apply a SRQ (selective ARQ) technique [12] illustrated in Fig. 5. When the transmission of OFDM

data packets proceeds, the BER is calculated for every packet and if the errors are uncorrectable by correction coding, the OFDM packet should be transmitted again. An SRQ packet is issued including indexes of packets to be retransmitted. ‘Sender’ retransmits Q packets specified by the SRQ. If the number Q of incorrect packets is large, it will be necessary to return to the handshake phase and re-measure the transmission properties of the channel.

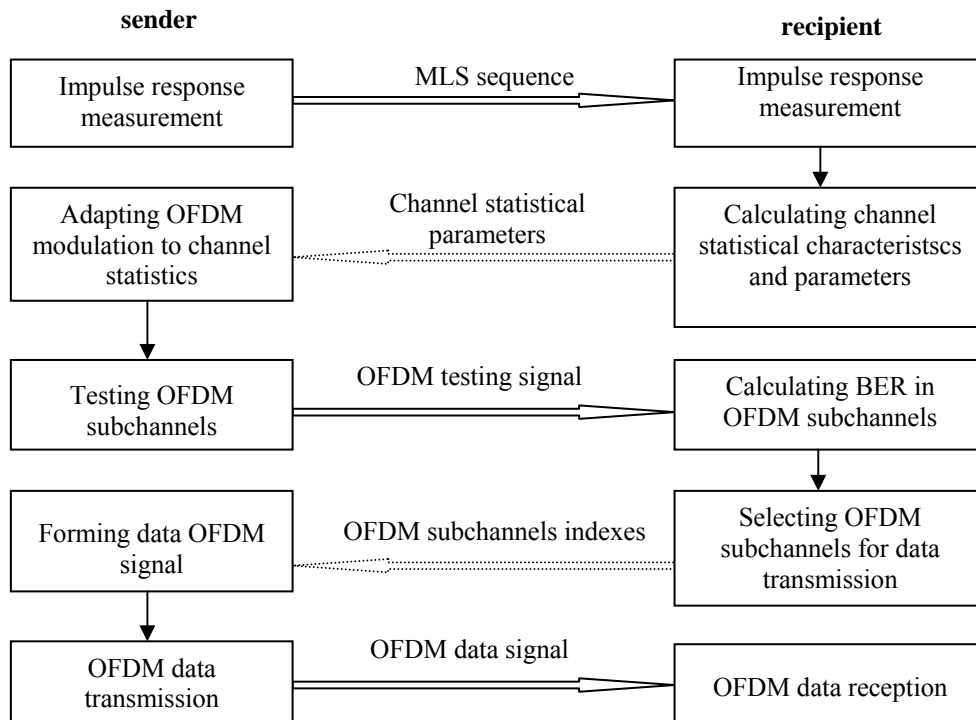

Fig. 4. Handshake of UAC system laboratory model based on OFDM technique

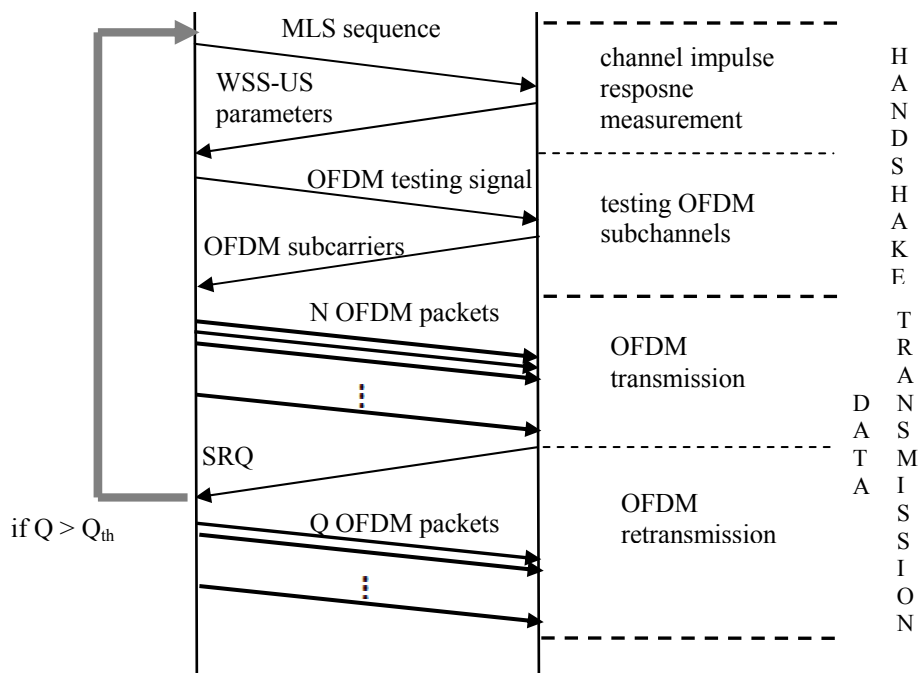

Fig. 5. SRQ mechanism for reliable data transmission

5. LABORATORY MODEL OF OFDM UAC SYSTEM

The adaptive OFDM technique is implemented in a laboratory model of underwater communication system. (Fig. 6). Both system 'sender' and 'recipient' consist of portable computer, acoustic amplifier, electroacoustic transmitting transducer and hydroacoustic receiving transducer with preamplifier.

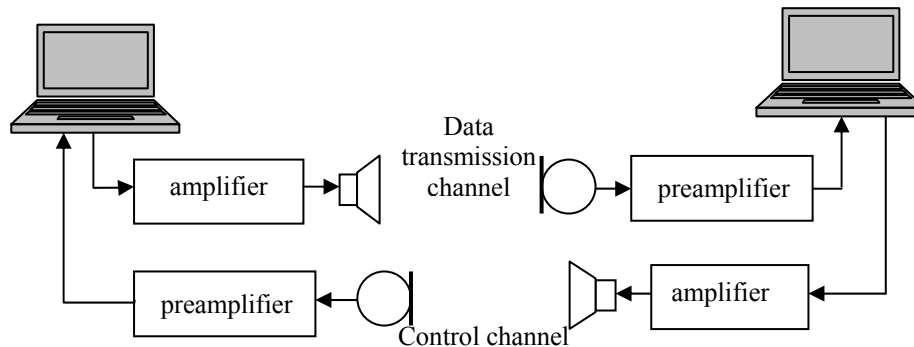

Fig. 6. Laboratory model of underwater OFDM communication system

Matlab computing environment was chosen for software development of the data transmission system. Matlab environment meets the project requirements. It performs matrix processing and storing large amount of data, which in the laboratory model corresponds to even a few minutes of sound signal sampled at 44.1 kHz.

The transmission is controlled with Data Acquisition Toolbox – a set of development tools enabling Matlab support of the analog input and output of a computer sound device. Using the software interrupt system, offered by Data Acquisition Toolbox, real-time transmission in half-duplex mode is performed.

6. CONCLUSIONS

Depending on the class of channels, determined by the geometric situation, the use of different link-layer protocols is required as well as correctly designed signal parameters at the physical layer data level.

Radio systems offer more possibilities, while the UAC ones offer less. When using the WSS-US model and designing appropriate protocols, optimum transmission speeds can be achieved in given local conditions. Underwater communications systems are needed that would adapt to the variability of the channel. In the case of the most favorable conditions of a short range communication in deep water, the system would fully exploit its maximum predisposed data rate.

The OFDM modulation and coding scheme turns out to be very effective in exploiting the communication potential of UAC systems in natural transmission conditions of SUWA channel. The most promising results have been reached up till now when the communication was additionally spatially split among several transmitters and receivers, i.e. the so-called multiple input multiple output (MIMO) approach was superimposed on the 'classical' one-channel OFDM technique.

REFERENCES

- [1] Yong Soo Cho, Jaekwon Kim, Won Young Yang, MIMO-OFDM Wireless Communications with MATLAB, Wiley 2010.

- [2] Stojanovic M., Adaptive Channel Estimation for Underwater Acoustic MIMO OFDM Systems, in Proc. IEEE DSP/SPE Workshop 2009, Marco Island, FL, January 2009.
- [3] Lasota H., Kochańska I., Transmission Parameters of Underwater Communication Channels, *Hydroacoustics*, 2011, Vol. 14.
- [4] <http://wapedia.mobi/pl/OFDM>.
- [5] Prasad R., *OFDM for Wireless Communications Systems*, Artech House, 2004, pp 24–25.
- [6] <http://www.3gpp.org/LTE>.
- [7] <http://www.radio-electronics.com/info/cellulartelecomms/lte-long-term-evolution/lte-ofdm-ofdma-scdma.php>.
- [8] Sesia S., Toufik I., Baker M., *The UMTS Long Term Evolution: From Theory to Practice*, Wiley 2009, pp. 478–479.
- [9] Borowski B., Characterization of a Very Shallow Water Acoustic Communication Channel, Proceedings of MTS/IEEE OCEANS 2009, Biloxi, Mississippi, October 2009.
- [10] Li B., Huang J., Zhou S., Ball K., Stojanovic M., Freitag L., Willett P., MIMO-OFDM for High Rate Underwater Acoustic Communications, *IEEE Journal of Oceanic Engineering*, Vol. 34, No 4, (2009), 634–645.
- [11] Sklar B., *Digital Communications: Fundamentals and Applications (2nd Edition)*, Prentice-Hall, 2001, pp. 944–996.
- [12] Rice J., Seaweb acoustic communication and navigation networks, Proceedings of the International Conference ‘Underwater Acoustic Measurements: Technologies & Results’, Heraklion, Crete, Greece, 2005.