

Automatic tuning of a resonant circuit in wireless power supply systems for biomedical sensors

G. BLAKIEWICZ*, J. JAKUSZ, W. JENDERNALIK, and S. SZCZEPAŃSKI

Faculty of Electronics, Telecommunications and Informatics, Gdańsk University of Technology,
11/12 Narutowicza St., 80-233 Gdańsk, Poland

Abstract. In this paper, a tuning method of a resonant circuit suited for wireless powering of miniature endoscopic capsules is presented and discussed. The method allows for an automatic tuning of the resonant frequency and matching impedance of a full wave rectifier loading the resonant circuit. Thereby, the receiver tunes so as to obtain the highest power efficiency under given conditions of transmission. A prototype receiver for wireless power reception, fabricated in in AMS CMOS 0.35 μm technology, was used to verify correct operation of the proposed tuning. The prototype system produces a stable supply voltage, adjustable in the range of 1.2–1.8 V at a maximum output current of 100–67 mA, which is sufficient to power a typical endoscopic capsule.

Key words: CMOS circuits, automatic tuning, impedance matching, resonant circuit.

1. Introduction

In recent years, wireless power supply systems are frequently used to provide power to electronic equipment [1, 2]. Systems of this type differ in terms of transmission range and level of transmitted power. For example, wireless chargers for smartphones or toothbrushes transmit several watts of power over relatively small distance of 1–2 cm. Such systems are simple in construction because power receiving devices can be easily positioned at the optimum location for power transmission. Therefore, transmission conditions are quite repeatable and for this reason no additional tuning circuit is required. The situation is completely different when power is delivered to certain biomedical sensors. The most difficult power supply conditions are in the case of endoscopic capsules. Although in these capsules supplied power is relatively small (100–150 mW), large changes in transmission conditions occur. During diagnostic tests a capsule moves along the gastrointestinal tract and its position changes. The changes in distance and position of a capsule relative to a circuit sending power result in changes of coupling, which in turn causes variation of received power level. For this reason, in order to ensure a constant power level, it is necessary to apply additional mechanisms to control volume of received power and if it is too low – start tuning to the optimal conditions. The scale of the difficulty of this problem may be illustrated by the fact that in the worst case, coupling intensity between a capsule and a transmitter decreases by two orders of magnitude, which means that the level of received power is reduced by four orders of magnitude.

The problem of wireless power transfer between coupled coils was analyzed in many papers, for example in [3–8]. The

results of detailed analysis and experimental measurements show that with large changes of coupling, tuning of the resonant frequency and impedance adjustment must be applied in order to achieve sufficiently high efficiency of power transmission. The problem of a proper selection of a tuning circuit for biomedical sensors is further complicated by the need to obtain small size, and a requirement to work with a rectifier. Several types of tuning circuits for adaptation to changes in coil position were proposed in [3, 5–8]. Although the proposed solutions improve the transmission efficiency, they have certain limitations. For example, the solution [3] requires changes in distance between a coil and its coupling winding, which makes miniaturization impossible. Another tuning circuit, presented in [5] cannot work with certain rectifiers, because the circuit uses a matrix of capacitors that blocks flow of DC current required for proper operation of the rectifier. The solution [6] allows only for a limited adjustment to specified distance between transmitting and receiving coils, and therefore has a limited range of effective application. The other variants [7, 8] only use frequency tuning, which considerably limits possibility of obtaining high efficiency of power transmission.

In this paper the most difficult case, namely the wireless power transmission to an endoscopic capsule is considered. In this way, the proposed solution might find much wider application, both for powering the capsules as well as powering simpler devices while providing higher transmission efficiency than was previously possible to achieve. Furthermore, the tuning circuit can work with all types of rectifiers and can be largely miniaturized. In Section 2 conditions of power transmission to endoscopic capsules are outlined and discussed. The proposed tuning method and a tunable receiver for wireless power reception are presented in Section 3. In the next section results of measurements of an integrated prototype circuit are given. The final conclusions are summarized in the last section.

*e-mail: blak@eti.pg.gda.pl

2. Conditions of power transmission to endoscopic capsules

As mentioned in the introduction, the most difficult is the transmission of power to endoscopic capsules. In typical systems coils of relatively large size (15–30 cm in diameter), placed around body of a patient, are used for sending power. Due to limited size of a capsule, a receiving coil has very small dimensions, not greater than 1 cm in diameter. The distance between the coils can vary between several cm up to 25 cm, in the worst case. Taking into account the arrangement of the coils and the range of distance between them, one can estimate the magnetic coupling coefficient using [9]

$$k \cong \frac{r_{Rx}^2 r_{Tx}^2}{\sqrt{r_{Rx} r_{Tx}} \sqrt[3]{x^2 + r_{Rx}^2}}, \quad (1)$$

where: k is the magnetic coupling, r_{Rx} and r_{Tx} are the radii of the receiving and transmitting coils, and x is a distance between them. Although the equation assumes that both coils are parallel and center aligned with only air between them, however it allows a good estimation of the order of the coupling changes. It should be mentioned that the influence of the coils misalignment can be minimized using a special power transmitting system composed of three coils, as described in [10]. For the assumed data, the coupling coefficient varies in the range $k \approx 0.2\text{--}0.001$. For two coils system, the maximum achievable power efficiency η can be determined based on [11]

$$\eta = \frac{k^2 Q_{Rx} Q_{Tx}}{\left(1 + \sqrt{1 + k^2 Q_{Rx} Q_{Tx}}\right)^2}, \quad (2)$$

where: Q_{Rx} and Q_{Tx} are the quality factors of the unloaded receiving and transmitting coils. The equation (2) is derived under the conditions of the optimal matching, which can be explained by referring to Fig. 1.

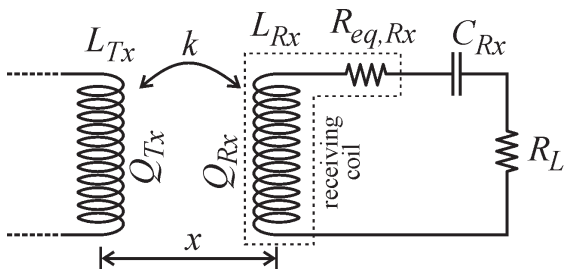

Fig. 1. Equivalent circuit of the coupled coils

The maximum power efficiency (2) is achieved only when frequency of transmitted signal is tuned to the system resonant frequency $f_r = (2\pi\sqrt{L_{Rx}C_{Rx}})^{-1}$, and when the equivalent series resistance $R_{eq,Rx}$ of the receiving coil is optimal, equal to [11]

$$R_{eq,Rx}|_{optimal} = \frac{R_L}{2} \frac{\sqrt{1 + k^2 Q_{Rx} Q_{Tx}}}{Q_{Rx}^2} \quad (3)$$

where R_L is the load resistance on which received power is dissipated. Assuming coils quality factors $Q_{Rx} = Q_{Tx} = 150$, and the previously calculated range of the coupling coefficient k , the maximum achievable power efficiency may vary from 92% to 0.95% for the coil separation ranging from 5 cm to 25 cm. It is important to notice that the optimal equivalent resistance (3) depends on both the coupling coefficient k and the load resistance R_L . Thus, the perfect tuning system should adapt the resistance $R_{eq,Rx}$ to every change of the coils separation x and actual value of the current consumed by a biomedical sensor, which depends on its activity. The direct changing of the equivalent resistance $R_{eq,Rx}$ would be impractical, because the resistance $R_{eq,Rx}$ depends on the unloaded coil quality Q_{Rx} which is related to its construction, and cannot be easily modified. Moreover, according to the equation (2), deliberate reduction of the quality factor Q_{Rx} for example by introduction of additional series resistance to the circuit, would reduce the system overall power efficiency η . In this situation, a much better method of achieving the optimal conditions is to transform the load resistance R_L to value that meets the condition (3). One of the impedance transformation circuits, shown in Fig. 2, can be utilized to accomplish that task.

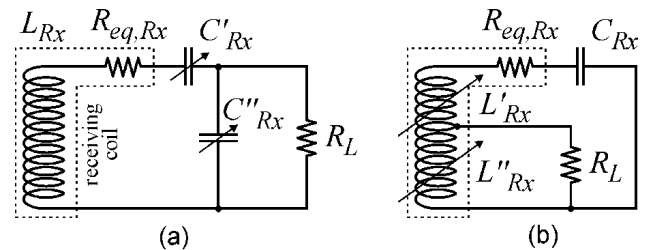

Fig. 2. Tuning circuits using load transformation based on: (a) capacitor divider [5], (b) inductance divider

Each circuit presented in Fig. 2 can transform the load resistance to the optimal value by a proper selection of the capacitances ratio $C'_{Rx} / (C'_{Rx} + C''_{Rx})$ or the inductances ratio $L''_{Rx} / (L'_{Rx} + L''_{Rx})$, but each variant has limitation. The circuit in Fig. 2a [5] can be easily implemented using two matrices of switched capacitors, but cannot be applied to match impedance of a full wave rectifier connected before R_L . It is because such a rectifier require a DC current path for a proper operation. A serious disadvantage of the circuit in Fig. 2b is the need of using two variable inductances, which cannot be implemented in a miniature medical sensor. A practical solution to the outlined problem is presented in the next section.

3. Tuneable receiver for wireless power reception

The proposed tuning circuit is shown in Fig. 3. The circuit consists of a coil with a tap and two matrices of switched capacitors. Because the load resistance R_L is directly connected

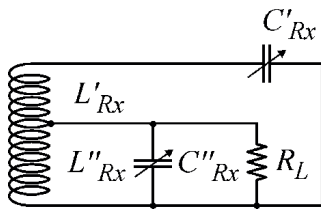

Fig. 3. Proposed tuning circuit

to the tap, it is possible to insert a full wave rectifier before R_L since a DC current path exists. This circuit can realize each of the design alternatives shown in Fig. 2. When the condition $|\omega C''_{Rx}| > 1/|\omega L''_{Rx}|$ is fulfilled the circuit realizes an equivalent of the matching circuit shown in Fig. 2a with an additional DC path, because the inductance L''_{Rx} is overcompensated by the capacitance C''_{Rx} at the working frequency ω . Otherwise, the circuit realizes the matching configuration presented in Fig. 2b. From a practical point of view, the first tuning variant is better, because it allows for wider tuning of the equivalent resistance $R_{eq,Rx}$ for a usable range of capacitances and inductances. For the assumed parameters, the equivalent resistance $R_{eq,Rx}$ varies from about 2Ω to below 0.001Ω for change of the load resistance from $R_L = 2 \text{ k}\Omega$ to 18Ω and the magnetic coupling coefficient k from 0.2 to 0.001. For the receive coil having $Q_{Rx} = 150$ and $L'_{Rx} + L''_{Rx} = 33 \mu\text{H}$, its series resistance is about 1.4Ω . Therefore, the optimal condition for power transmission can only be reached for a limited range of load resistance (large to moderate) and small distance between the coils, where $R_{eq,Rx} \geq 1.4 \Omega$. For heavy load and large separation the system

works suboptimally. In this case, a necessary condition for obtaining the optimal operation is to use the coils with much greater quality factor, which is difficult to achieve in practice.

The main idea of a tunable receiver for reception of wireless power is presented in Fig. 4. The receiver consists of two programmable capacitor matrixes used to adjust capacitances C''_{Rx} and C'_{Rx} , shown in Fig. 3. The electric energy captured by the coil L_1 is processed by a full wave bridge rectifier, connected to the tap, and next is filtered by an energy storage capacitor C_f . The level of the supply voltage V_o is controlled by a power management circuit, which additionally monitors volume of received energy and protects against excessive increase of the supply voltage V_o during strong coupling between the transmitter and receiver. Too high supply voltage could damage low-voltage filters, amplifiers, and image processing circuits [12, 13] inside the capsule. If the level of received power is too low, a tuning cycle is initialized to adjust parameters of the resonant circuit. The tuning is accomplished by activation of a binary counter, which counts the master clock CLK pulses. The set of MOS transistors $M_{Q0}-M_{Q7}$, connected to the counter outputs, switches the capacitors C_0-C_7 belonging to C''_{Rx} and C'_{Rx} matrixes. The capacitors in each matrix are binary-weighted, namely $C_6 = 2C_7, \dots, C_3 = 2C_4$, and $C_1 = 2C_2, C_0 = 2C_1$. The capacitor C_8 was selected to tune the coil L_1 to the nominal resonant frequency greater by 10%, thus a capability of retuning the resonant circuit within $\pm 20\%$ was achieved. In the prototype solution $C_8 = 634 \text{ pF}, C_7 = 10.64 \text{ pF}, C_2 = 1.3 \text{ nF}, L_1 = 33 \mu\text{H}$. Due to limitations of the technology used, all the capacitors are realized as off-chip. The power management system, depicted in Fig. 5, comprises: a parallel voltage regulator (M_1-M_8), a com-

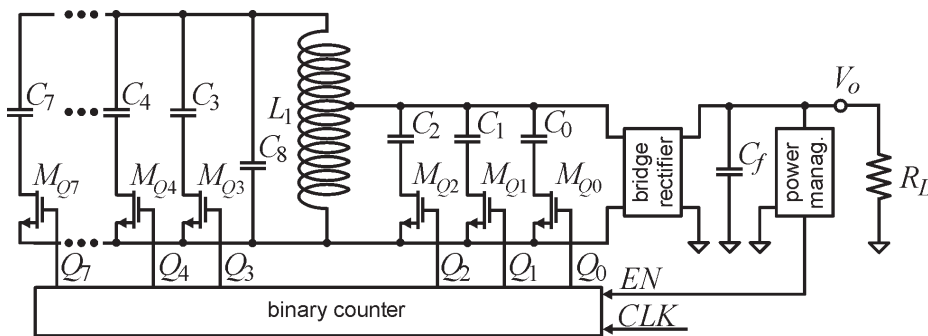

Fig. 4. A simplified schematic of a receiver for wireless power reception

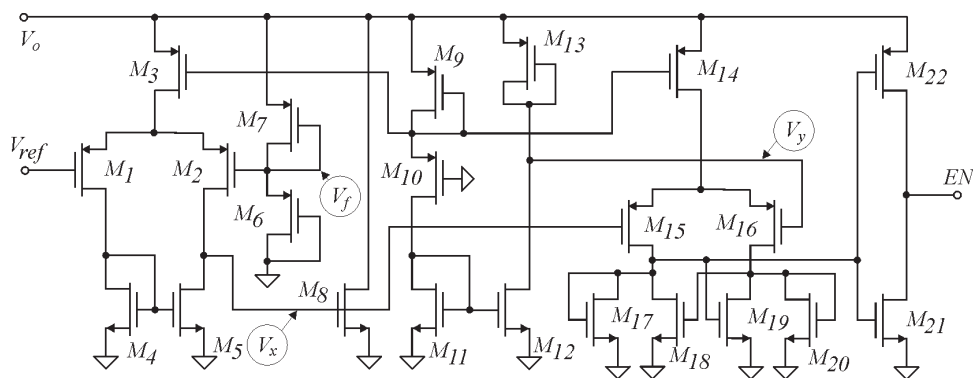

Fig. 5. A schematic of a power management circuit

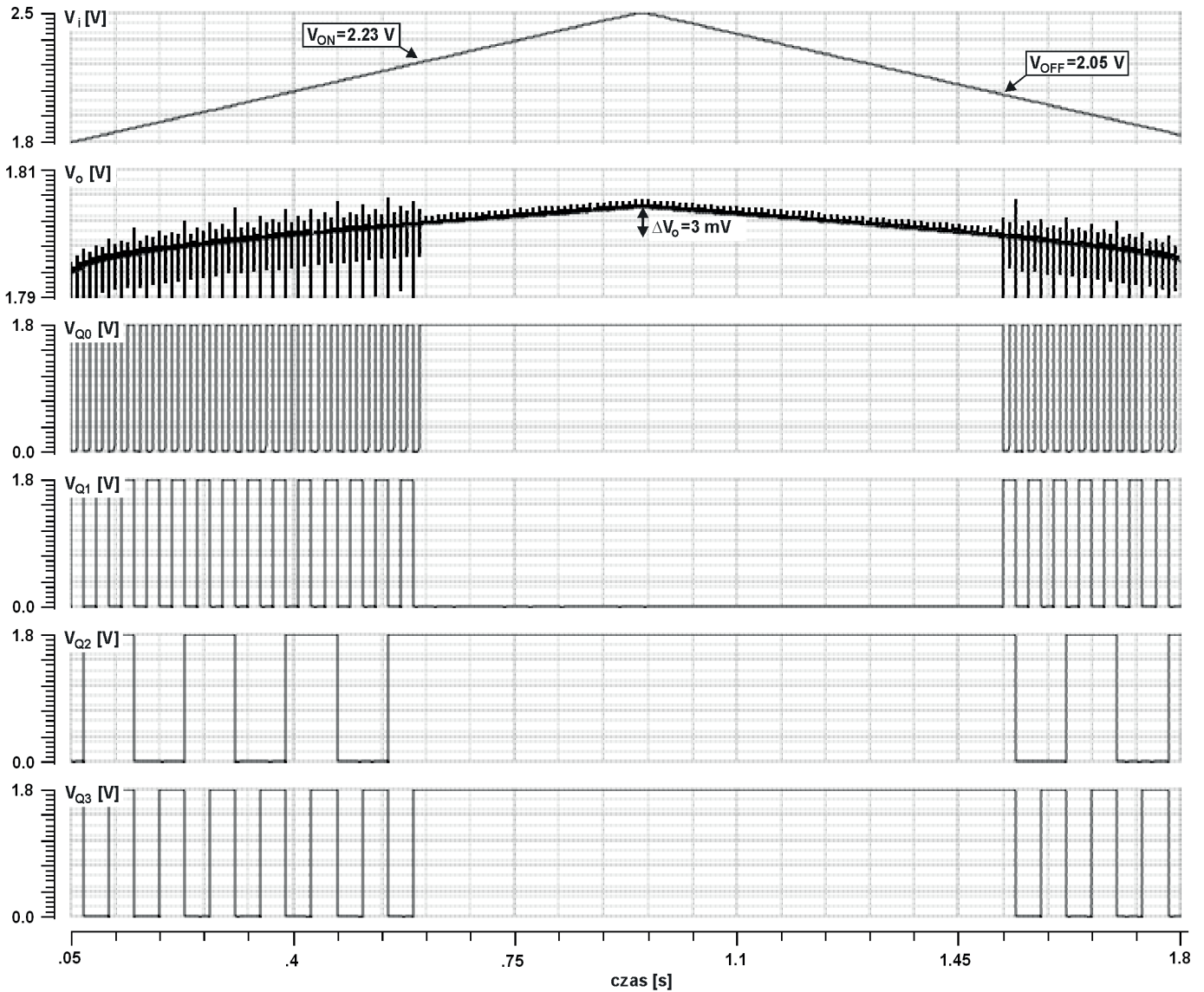

Fig. 6. Example of a tuning cycle

parator of received energy level (M_{14} – M_{20}), a biasing circuit (M_9 – M_{13}), and an inverter (M_{21} – M_{22}) that shapes the enable signal EN used for activation of the counter. In the voltage regulator, the reference voltage V_{ref} is compared with the feedback signal V_f and the error signal V_x is generated to control the parallel transistor M_8 . Because the signal V_x is proportional to level of received power, by comparing this voltage to the required power threshold, defined by the voltage V_y , state of tuning process is determined. When received power is too small the enable signal EN is activated and tuning process starts. As soon as received power reaches a threshold level, the signal EN is reset to low and tuning stops. To protect the tuning system against temporary fluctuations of received power a comparator with hysteresis is used. Therefore, tuning process is interrupted when received power level is greater than the minimum, and is resumed when power falls to the minimum level. Dimensions of the transistors used are as follow: $M_1, M_2 = 50/1$;

$M_4, M_5, M_9 - M_{11}, M_{14} M_{21} = 2/0.5$; $M_8 = 3000/0.35$; $M_3, M_{15}, M_{16} = 20/0.5$; $M_6, M_7 = 2/5$; $M_{12} = 1/1.5$; $M_{13} = 2/2$; $M_{17}, M_{20} = 1.5/5$; $M_{18}, M_{19} = 1.5/0.5$; $M_{22} = 2/1.5$. The current biasing an error amplifier in the voltage regulator is $I_{d3} = 2.3 \mu A$, whereas current biasing the comparator is $I_{d14} = 0.3 \mu A$. An exemplary tuning cycle is presented in Fig. 6, where: V_i represents level of received power, V_o is a regulated supply voltage, and V_{Q0} – V_{Q3} are the signals controlling the transistors M_{Q0} – M_{Q3} that switch capacitors in the matrix. The plot shows that at a low power level cyclic tuning of the resonant circuit is carried out. When the required power threshold (represented by the level $V_i = 2,23$ V) is reached, tuning is halted and the capacitor matrix is locked in the state: M_{Q0}, M_{Q2}, M_{Q3} – switched on, and M_{Q1} – switched off. With a drop in received power to the minimum level ($V_i = 2,05$ V) the tuning process is resumed. The less significant bits (Q_3 – Q_7) of the counter are used for C_{Rx} tuning, which is mainly responsible for the resonant frequency, whereas

the more significant bits (Q_2-Q_0) are reserved for changing C''_{Rx} affecting mainly the impedance transformation. Such a bit allocation enhances fluency of tuning, because change in transmission conditions most affects detuning of the resonant frequency, which in the first place should be corrected.

4. Results of prototype circuit measurements

Operation of the designed tuning system has been practically tested using a prototype integrated circuit. Due to limited budget for prototyping, AMS CMOS 0.35 μm technology was used. For this reason part of the circuit, namely the matrix capacitors were designed as off-chip components. A rectangular transmit coil of dimensions $25 \times 25 \text{ cm}^2$ and a circular receiving coil of diameter 1 cm were used for tests. To obtain high quality factors, the coils were wound with HF litz. The coils were tuned to the resonant frequency of 1 MHz. Examples of measured time response are illustrated in Fig. 7. The plot in Fig. 7a shows the output voltage of a rectifier during tuning process. In order to show a complete cycle, the blocking of the

counter was disabled. From the plot one can observe a gradual tuning of the circuit to the resonance with two jumps related to changes in matching of the rectifier impedance. The results show a significant impact of a proper matching of the rectifier impedance. The second plot in Fig. 7b shows a response of the regulator output voltage V_o to abrupt change of output current. Change of current equal to $\Delta I_o = 21 \text{ mA}$ results in voltage drop $\Delta V_o = 19 \text{ mV}$ which indicates that the regulator output resistance is $R_o = 0.9 \Omega$. Other tests performed show that the developed receiver can be used to power endoscopic capsules with a maximum power consumption limited to 120 mW. A summary of important parameters of the prototype power management system is presented in Table 1.

Table 1
Parameters of the prototype power management system

Parameter	Value
Technology and dimensions	CMOS 0.35 μm 110x62 μm^2
Maximum output current	100 mA
Adjustment range of stabilized voltage	1.2 – 1.8 V
Output resistance	0.9 Ω
Output voltage change for transmitted power change 50 – 100 %	5%
Efficiency of the parallel voltage regulator under minimum transmitted power, for the output current $I_o = 1 \text{ mA}$ and $I_o = 100 \text{ mA}$	99.7%, $I_o=1 \text{ mA}$ $\approx 100\%$, $I_o=100 \text{ mA}$

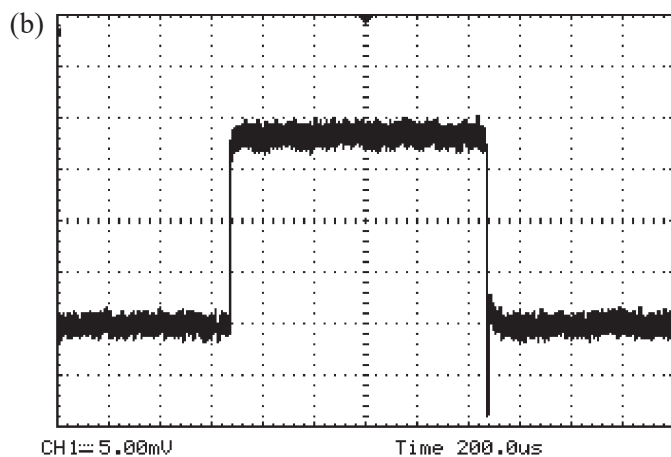
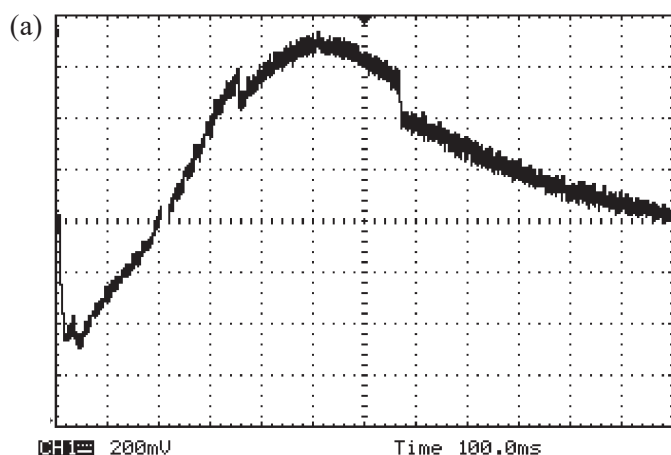

Fig. 7. Examples of the tuning system time responses: a) output voltage of the rectifier during tuning process, b) response of the regulator output voltage V_o to current change

5. Conclusions

A tuning method of a resonant circuit suited for wireless powering of miniature endoscopic capsules is presented and discussed. In order to practically test the proposed method, a prototype receiver for wireless power reception, fabricated in AMS CMOS 0.35 μm technology, was designed. The measurement results show that the receiver automatically tunes to the frequency at which power is transmitted. After an initial frequency tuning, the system adjusts matching of a rectifier impedance so as to achieve a better condition for reception of energy. A relatively high efficiency of power reception was achieved by applying tuning and a power management circuit. The prototype system produces a stable supply voltage, adjustable in the range of 1.2–1.8 V, at a maximum output current of 100–67 mA, which is sufficient to power a typical endoscopic capsule.

Acknowledgments. This work was supported in part by the Polish Ministry of Science and Higher Education, grant 2011/03/B/ST7/03547.

REFERENCES

- [1] O. Lazaro, G.A. Rincon-Mora, "180-nm CMOS wideband capacitor-free inductively coupled power receiver and charger", *IEEE J. Solid-State Circ.*, 48 (11), 2839–2849 (2011).
- [2] Ch. Hao, Y. Jia, X. Liu, R.-F. Xue, H.J. Lim, P.B. Khannur, K.L. Chan, A.A. Lee, K. Kang, L.S. Lim, C. He, P. Singh, P. Woo-Tae, J. Minkyu, "An inductively powered implantable blood flow sensor microsystem for vascular grafts", *IEEE Trans. Biomed. Eng.*, 58 (2), 2466–2475 (2011).
- [3] Ch.-J. Chen, T.-H. Chu, Ch.-L. Lin, Z.-Ch. Jou, "A study of loosely coupled coils for wireless power transfer", *IEEE Trans. Circ. Syst. II: Exp. Briefs*, 57 (7), 536–540 (2010).
- [4] K. Fotopoulou, B. W. Flynn, "Wireless power transfer in loosely coupled links: coil misalignment model", *IEEE Trans. Magnetics*, 47 (2), 416 – 430 (2011).
- [5] J. Lee Y.-S. Lim, W.-J. Yang, S.-O. Lim, "Wireless power transfer system adaptive to change in coil separation", *IEEE Trans. Antennas and Propagation*, 62 (2), 889–897 (2014).
- [6] R.-F. Xue, K.-W. Cheng, M. Je, "High-efficiency wireless power transfer for biomedical implants by optimal resonant load transformation", *IEEE Trans. Circ. Syst. I: Reg. Papers*, 60 (4), 867–874 (2013).
- [7] N.Y. Kim, K.Y. Kim, J. Choi, C.-W. Kim, "Adaptive frequency with power-level tracking system for efficient magnetic resonance wireless power transfer", *Electr. Letters*, 48 (8), 452–454 (2012).
- [8] A.P. Sample, D.A. Meyer, J.R. Smith, "Analysis, experimental results, and range adaptation of magnetically coupled resonators for wireless power transfer", *IEEE Trans. Industrial Electronics*, 58 (2), 544–554, (2011).
- [9] C. Sauer, M. Stanacevic, G. Cauwenberghs, N. Thakor, "Power harvesting and telemetry in CMOS for implanted devices", *IEEE Trans. Circ. Syst. I: Reg. Papers*, 58 (12), 2605–2613 (2005).
- [10] G. Blakiewicz, "Bezprzewodowe zasilanie sensorów medycznych", *Przegląd Elektrotechniczny* 9, 12–14, (2014).
- [11] W.H. Ko, S.P. Liang, C. Fung, „Design of radio-frequency powered coils for implant instruments”, *Medical & Biological Engineering & Computing* 15, 634–640, (1977).
- [12] G. Blakiewicz, "Technique to improve CMRR at high frequencies in CMOS OTA-C filters", *Bull. Pol. Ac.: Tech.* 61 (3), 697–703 (2013).
- [13] W. Jendernalik, J. Jakusz, G. Blakiewicz, R. Piotrowski, S. Szczepański, "CMOS realisation of analogue processor for early vision processing", *Bull. Pol. Ac.: Tech.* 59 (2), 141–147, (2011).