

# Balancing energy consumption in limited power grid with active front-end and three phase dual active bridge system

Konstantin Vorobev

School of Computer Technologies and Control  
Faculty of Control Systems and Robotics  
ITMO University  
Saint-Petersburg, Russia  
mail@niuitmo.ru

Ryszard Strzelecki

Faculty of Electrical and Control Engineering,  
Gdańsk University of Technology  
Gdańsk, Poland  
<https://orcid.org/0000-0001-9437-9450>

Nikolai Poliakov

School of Computer Technologies and Control  
Faculty of Control Systems and Robotics  
ITMO University  
Saint-Petersburg, Russia  
<https://orcid.org/0000-0002-0263-4811>

**Abstract**—Paper deals with simulation analysis of bidirectional power converters system for charging station of electric vehicle in condition of limited power source in city infrastructure. In case of incapability to provide additional power supply through the grid by virtue of historical, architectural and economic reasons it is possible to solve this issue by implementation of mobile battery-powered supply source. The proposed bidirectional power converters system for consist of three-phase dual active bridge two-directional converter and active front end. Bidirectional power converters system operation modes considered in the paper include transmission of energy from both the battery station, and grid and the joint power supply with battery and grid.

**Keywords**— Power systems, emergency power supplies, DC-DC power converters, phase modulation, single-phase switch, power system modeling, three phase dual active bridge; power reserving

## I. INTRODUCTION

With the growing demand for electric vehicles (EV), there appears issues related with providing its charge. An example of this problem is the UPS delivery service plan to increase fleet of electric vehicles trucks in central London from 65 to 170 available in the near future. The project is called Smart Electric Urban Logistics (SEUL)." The ultimate goal of this project should be the emergence of an intelligent power grid, a complete transition to electric vehicles, the use of renewable energy within the city, improving the environmental situation, reducing the cost electricity below diesel levels. At the moment, the project is limited with the maximum of power consumed from the grid. Implementation of an intelligent power grid could be the solution to the problem. At the moment, the charging of transport is carried out at night, due to the reduction of the load on the grid from the city [1], [2].

Further improvement in this field could be achieved if external power storage based on mobile battery-powered supply source will be implemented for EV charging station. The benefits of this solution are possibility to increase power of charging station without changing limits of power consumption from city power grid This in turns allows to increase number of simultaneously charging EVs or decrease

charging time by increasing charging power of singular EV. Mobile battery-powered supply source combined with EV station also can be used as an energy storage in the daytime, which takes energy from renewable sources and returns unused energy to the city's grid through additional input terminals (Fig.1).

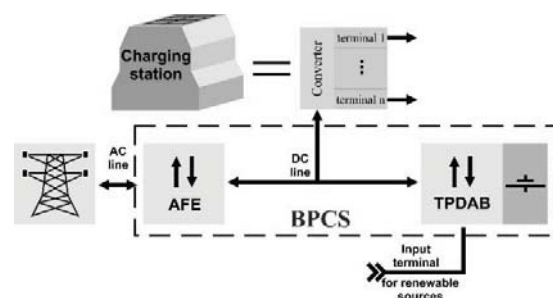

Fig. 1. Grid structure

This paper proposes the solution for such improvements which is based on bidirectional power converters system (BPCS). Proposed system consists of three-phase dual active bridge (TPDAB) and active front end (AFE). TPDAB provides energy transferring from mobile energy storage. Galvanic isolation between terminals is necessary for charging devices supplied from common DC link. Three-phase topology should ensures a gain in size, an increase in power and a reduction of the current load on the converter transistors in comparison with single-phase topology [3]–[7].

An advantage of proposed BPCS is an opportunity to control in wide range power flows between AC grid, DC battery source and high-power load in condition of limited power supply of grid power source. This paper is mostly focused on an operation mode of joint energy consumption from the electricity grid and the battery which can be realized with AFE implemented as a AC-DC converter providing a two-way exchange of energy with the AC grid and controlling the current consumed from it.

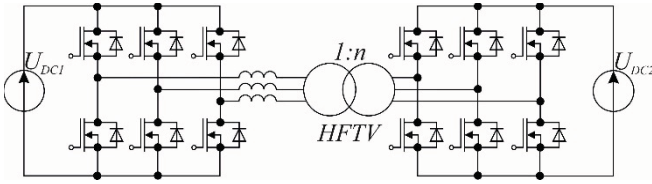

Fig. 2. A TPDAB scheme

## II. TPDAB

The generalized TPDAB scheme is presented in Fig. 2 and includes two three-phase inverters, a three-phase high-frequency transformer and an inductor with equal inductiveness in phases.

The mathematical description of the converter is presented in [8]. Single phase switch (SPS) is used as a switching method. In this case, the switching of one inverter is carried out by a meander with a shift of  $\frac{\pi}{3}$  between the phases (Fig. 3a). The control of the TPDAB is carried out by the shift angle  $\theta = 2\pi \frac{t}{T_s}$  between control impulses of the two inverters, where  $T_s$  - the switching period,  $t$  - the time difference between the pulses of inverters (Fig. 3b).

The output characteristic of TPDAB is the dependence of power transferred between its terminals from the angle of the  $\theta$  [8], [9] (Fig. 4):

$$P(\theta) = \frac{U_{DC1}^2}{\omega L} d \theta \left( \frac{2}{3} - \frac{\theta}{2\pi} \right) \text{ for } 0 \leq \theta \leq \frac{\pi}{3} \quad (1)$$

$$P(\theta) = \frac{U_{DC1}^2}{\omega L} d \left( \theta - \frac{\theta^2}{\pi} - \frac{\pi}{18} \right) \text{ for } \frac{\pi}{3} \leq \theta \leq \frac{\pi}{2} \quad (2)$$

where  $\omega = 2\pi f_s$ ,  $f_s = \frac{1}{T_s}$  - switching frequency,

$d = \frac{U_{DC2}}{nU_{DC1}}$  - DC voltage ratio between terminals,  
 $n$  - transformation ratio.

## III. USE OF BPCS

In the context of the task, the main application of BPCS is to increase the maximum power provided to the EV charging station and to reconcile this power with the power of the grid source and battery source of energy connected to the station. It can be presented as a simple structural scheme (Fig. 5a). The two main nodes of BPCS is TPDAB and AFE that supply DC voltage to the chargers connected to the DC common link. As a result, there are four main operation modes: consuming power from AC grid by AFE only (Fig. 5b), consuming power from DC source connected to TPDAB (Fig. 5c), regeneration of unused energy from DC source to AC grid (Fig. 5d), joint work on output DC line using AC grid and DC source (Fig. 5e). Last condition assumes that AC line power is limited, and maximum load power is higher than power of AC grid. The additional condition for the last operation mode is to provide minimal impact on the grid source in order to ensure power supply to other consumers. Parameters of charging station was chosen on the basis of analysis of EV charging devices

standards [10]. The following output parameters were chosen:  $U_{out} = 700V$ ,  $P_{out} = 350kW$ ,  $U_{out\max} = 920V$ . (Here and further the load is presented as active constant load in DC link with equivalent power).

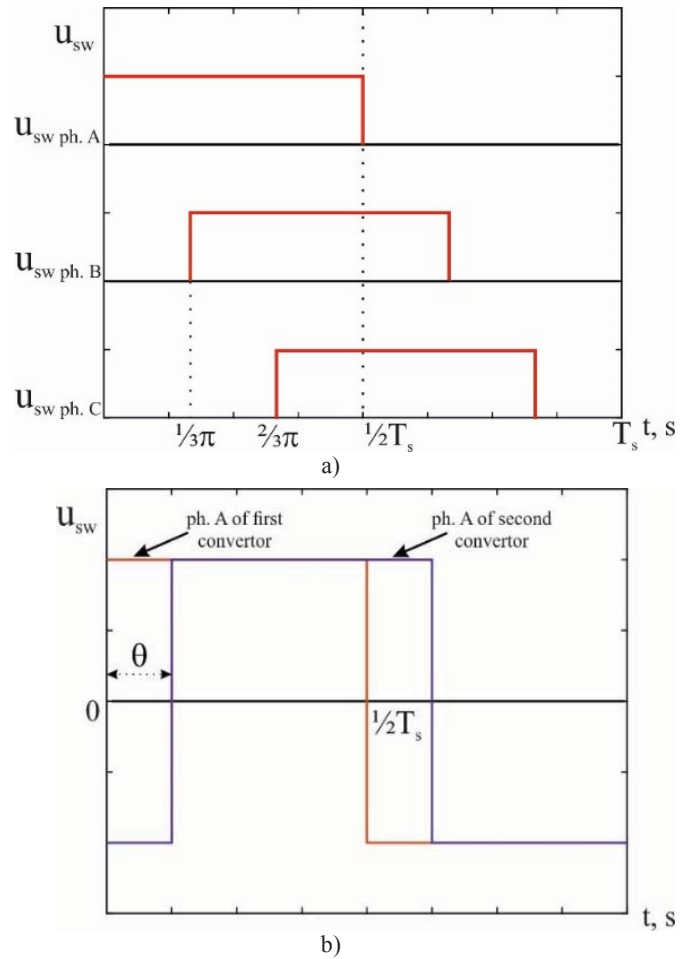

Fig. 3. SPS switching method

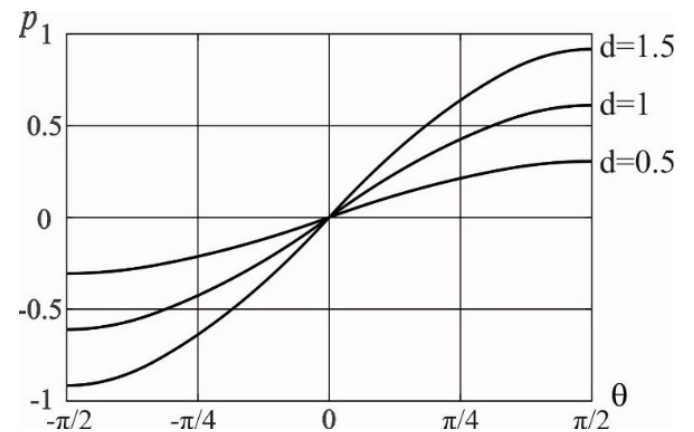

Fig. 4. Output power of TPDAB rationed to  $\frac{U_{DC}^2}{\omega L}$  in dependence on phase shift  $\theta$  and  $d$

The BPCS diagram (Fig. 6) displays the main nodes in the form of AFE, which uses a control system with space-vector modulation, [11], [12] and TPDAB with SPS modulation. The system's parameters are shown in Table I.

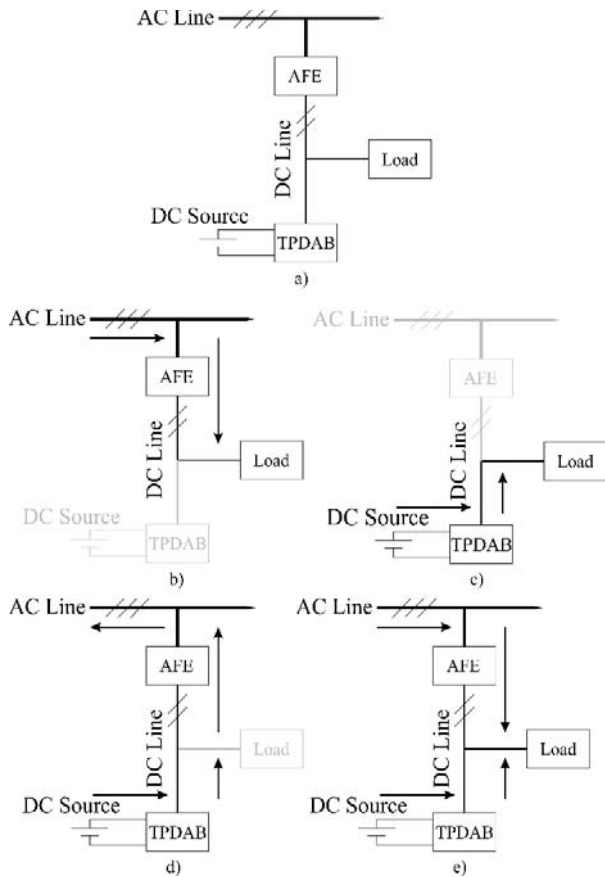

Fig. 5. Generalized view of BPCS structural scheme (a), BPCS operation modes: power supply from the grid (b), power supply from an external battery energy source (c), regeneration of unused energy to the grid (d), joint power supply with grid and external battery source (e)

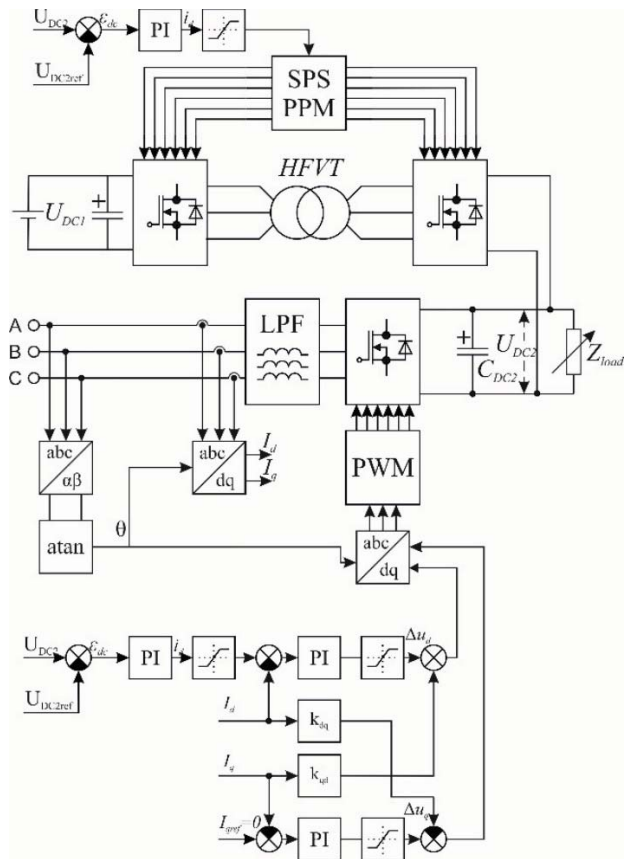

Fig. 6. Block diagram of BPCS

TABLE I. SUMMARY PARAMETERS AND BASE SIMULATION VALUES OF SYSTEM

Parameter	Value	Units
$U_{DC1}$	320	V
$U_{DC2}$	700	V
$U_{AC}$	220	V
$I_n$	500	A
$P_{out}$	350	kW
$f_{sw\ TPDAB}$	60	kHz
$f_{sw\ AFE}$	20	kHz
Trans. ratio $n$	2	-
$I_{AFE\ base} = \frac{P_{out}}{\sqrt{2}U_{AC}}$	1125	A
$U_{DC\ base} = U_{DC2}$	700	V
$U_{AC\ base} = U_{AC}$	220	V

It is possible to determine the value of the BPCS inductor calculated from settled power limit and (1)-(2),  $L \approx 12\mu H$ .

#### IV. SIMULATION

The simulations were made to prove functionality of the proposed BPCS in presented operation modes. The operation mode with power supply from external battery source was presented in fig. 7. With the parameters presented in Table 1, it is possible to ensure that it takes less than 2ms for transient time and overshoot of DC link voltage is less than 2.5%. AFE is disabled in this operation mode. In real situation that means AC grid failure which could be absence of input AC voltage or AC grid overload.

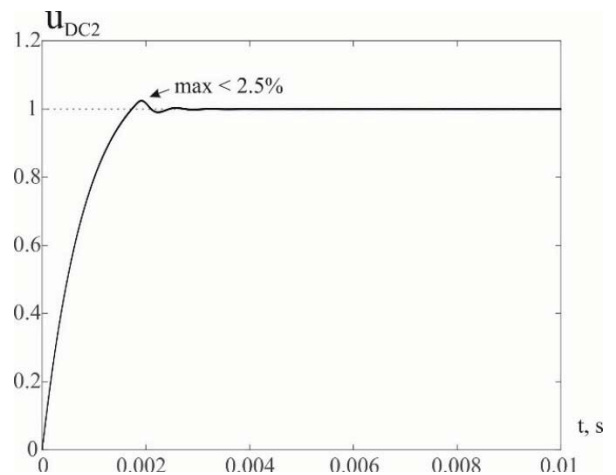

Fig. 7. The voltage on the DC link in power supply from external battery source operation mode in p.u.

In the second case DC link load is higher than power limit of the AC grid. AFE joint works with TPDAB on DC link load (fig 8). For ensuring of joint work input AFE current limited to 500A. In this case, the BPCS introduces a joint power supply with grid (through AFE) and battery source (through TPDAB) to maintain the voltage level on the DC link.

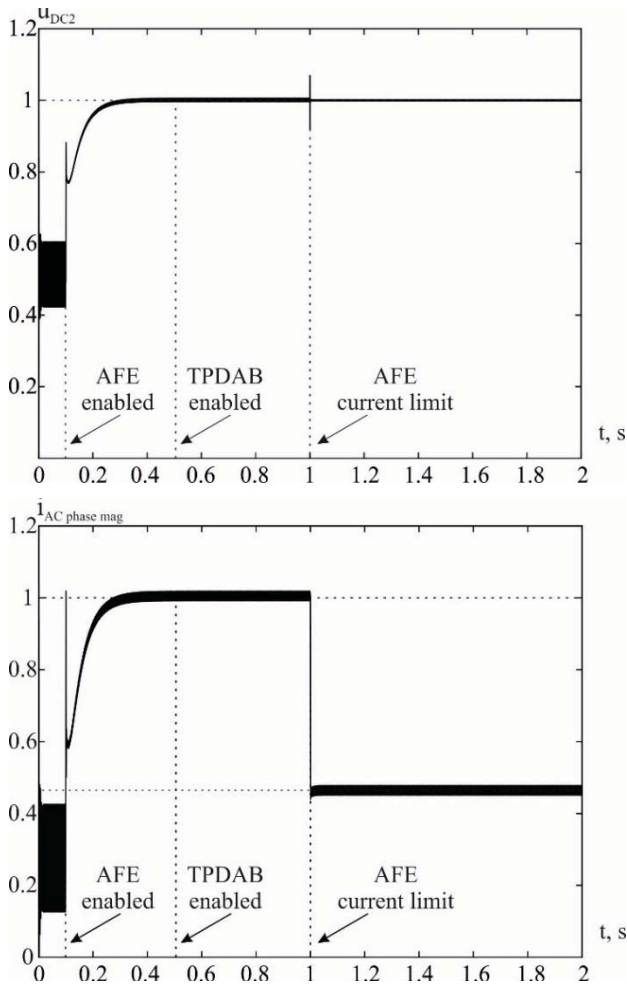

Fig. 8. Joint power supply from grid and battery sources, where (a) – output voltage of the DC link. b) – magnitude of AFE AC phase current. Values in p. u. from Table I.

The last simulation shows power regeneration to the AC grid from external battery. TPDAB stabilizes DC link at nominal voltage which may be critical for DC customers and AFE operations (Fig. 9).

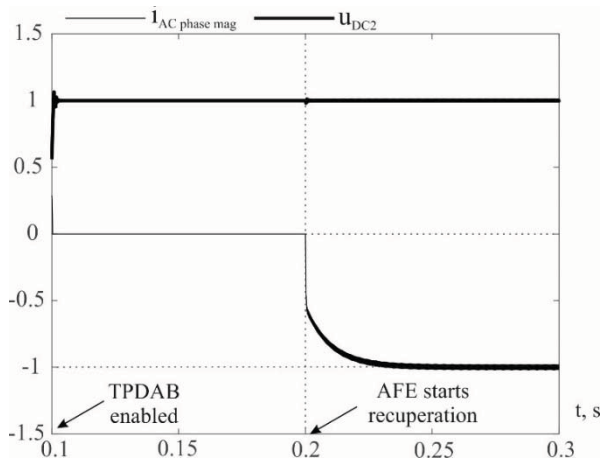

Fig. 9. Regeneration of unused energy to the grid operation mode – current magnitude of phase A and voltage in the DC link, in p. u.

## V. CONCLUSIONS

The proposed BPCS with TPDAB and AFE was tested in form of simulation study in conditions of different power flows between converters and terminals. It was shown that BPCS can balance power consumption from DC battery source and AC grid source in acceptable range of power consumption in condition of AC grid overload or fault operations.

The presented research is the preliminary part of a TPDAB based power converter design. Obtained results could be widely extended for microgrid systems power converter design and control algorithms. Further purpose of this research includes efficiency analysis of control strategy for BPCS for EV charging station. The research still underway.

## REFERENCES

- [1] K. Petrella, 'UPS To Deploy First Electric Truck To Rival Cost Of Conventional Fuel Vehicles', 22-Feb-2018. [Online]. Available: <https://pressroom.ups.com>.
- [2] K. Behal, 'UPS Switches On Smart Grid In London To Super-Charge Electric Delivery Fleet', *Cutting Edge Deployment of Advanced Technology Vehicle & Charging Signals Shift Away from Reliance on Combustion Engine*, 19-Mar-2018. [Online]. Available: <https://pressroom.ups.com>.
- [3] T. Jimichi, M. Kaymak, and Rik. W. De Doncker, 'Comparison of single-phase and three-phase dual-active bridge DC-DC converters with various semiconductor devices for offshore wind turbines', in *2017 IEEE 3rd International Future Energy Electronics Conference and ECCE Asia (IFEEC 2017 - ECCE Asia)*, Kaohsiung, Taiwan, 2017, pp. 591–596, doi: 10.1109/IFEEC.2017.7992105.
- [4] D. Segaran, D. G. Holmes, and B. P. McGrath, 'Comparative analysis of single-and Three-Phase Dual Active Bridge Bidirectional DC-DC Converters', *Aust. J. Electr. Electron. Eng.*, vol. 6, no. 3, pp. 329–337, Jan. 2009, doi: 10.1080/1448837X.2009.11464251.
- [5] H. van Hoek, M. Neubert, A. Kroeber, and R. W. De Doncker, 'Comparison of a single-phase and a three-phase dual active bridge with low-voltage, high-current output', in *2012 International Conference on Renewable Energy Research and Applications (ICRERA)*, Nagasaki, Japan, 2012, pp. 1–6, doi: 10.1109/ICRERA.2012.6477466.
- [6] S. Inoue and H. Akagi, 'A Bidirectional Isolated DC-DC Converter as a Core Circuit of the Next-Generation Medium-Voltage Power Conversion System', *IEEE Trans. Power Electron.*, vol. 22, no. 2, pp. 535–542, Mar. 2007, doi: 10.1109/TPEL.2006.889939.
- [7] S. Inoue and H. Akagi, 'A Bidirectional DC-DC Converter for an Energy Storage System With Galvanic Isolation', *IEEE Trans. Power Electron.*, vol. 22, no. 6, pp. 2299–2306, Nov. 2007, doi: 10.1109/TPEL.2007.909248.
- [8] R. W. A. A. De Doncker, D. M. Divan, and M. H. Kheraluwala, 'A three-phase soft-switched high-power-density DC/DC converter for high-power applications', *IEEE Trans. Ind. Appl.*, vol. 27, no. 1, pp. 63–73, Feb. 1991, doi: 10.1109/28.67533.
- [9] A.R. Prasad, P.D. Ziogas, and S. Manias, 'A three-phase resonant PWM DC-DC converter', presented at the PESC '91 Record 22nd Annual IEEE Power Electronics Specialists Conference, Cambridge, MA, USA, USA, 1991.
- [10] P. Chatterjee and M. Hermwille, 'Power Electronics Europe', *Electric Vehicle Fast Charging Challenges*, no. 1, pp. 30–32, 2019.
- [11] S. Albatran, Y. Fu, and A. Albanna, 'A hybrid 2D-3D SVM control algorithm for three phase voltage source inverters', in *2012 IEEE Power Electronics and Machines in Wind Applications*, Denver, CO, USA, 2012, pp. 1–6, doi: 10.1109/PEMWA.2012.6316357.
- [12] S. Albatran, Y. Fu, and A. Albanna, 'Comparative harmonic analysis of hybrid 2D-3D SVM and conventional 2D SVM', in *2013 IEEE 14th Workshop on Control and Modeling for Power Electronics (COMPEL)*, Salt Lake City, UT, USA, 2013, pp. 1–7, doi: 10.1109/COMPEL.2013.6626441.