

Bioaccumulation of Metals in Tissues of Marine Animals, Part I: the Role and Impact of Heavy Metals on Organisms

Anna Jakimska^{1*}, Piotr Konieczka¹, Krzysztof Skóra², Jacek Namieśnik^{1**}

¹Department of Analytical Chemistry, Chemical Faculty, Gdańsk University of Technology,
G. Narutowicza 11/12, 80-233 Gdańsk, Poland

²Marine Station Institute of Oceanography in Hel (G215)

Received: 30 May 2011

Accepted: 6 June 2011

Abstract

Heavy metals contribute to the anthropogenic contamination of marine ecosystems. Some of them are essential to the life processes of organisms; others are toxic, even at low concentrations. They penetrate organisms via food, respiratory pathways or the skin. The extent to which metals penetrate organisms is measured by bioconcentration and bioaccumulation factors and also by their transport between organisms at different trophic levels of an ecosystem. These factors define the course of metal bioaccumulation in the environment or in organisms, their organs, and tissues. Our paper discusses the role of heavy metals in organisms at different levels of the trophic pyramid (food web) and their influence on life processes. The levels of some elements, like Zn and Cu, are regulated by metabolic processes and are important constituents of enzymes and other compounds. Other such elements, e.g. Hg, Pb, and Cd, are toxic and may adversely affect DNA and enzymatic processes, hence interfere with life processes, even though organisms possess mechanisms for the detoxification and excretion of metals.

An important role in metal detoxification is performed by metallothionein (MT), which binds to toxic metals, thereby preventing organisms from harmful effects. Information about the increasing level of a metal is transmitted by the MT gene as it initiates expression regulated by zinc in order to bind MT with the metal. Elements like cadmium, copper, or mercury have a greater affinity for ligands than zinc, and will tend to displace it at MT binding sites. Structures from which zinc has been displaced take part in detoxification, thereby limiting the toxicity of such metals as Cd, Cu, or Hg.

Keywords: bioaccumulation, heavy metals, marine organisms, metallothionein

Introduction

Elements classified as heavy metals are significant pollutants of marine ecosystems [1]. The main sources of these contaminants are anthropogenic: communal sewage and industrial effluents, fuel combustion, mining, and smelting.

The term 'heavy metals' is usually applied to a group of metals and metalloids (and also their compounds) that are strongly toxic and ecotoxic, and hence are environmental contaminants [2]. Heavy metals can be subdivided as follows:

- Mn, Fe, Co, Cu, Zn, and Mo – elements essential for the growth and life cycles of organisms, but are toxic at high concentrations [3]
- Pb, Hg, and Cd – toxic even at low concentrations

*e-mail: anik.jakimus@interia.pl

**e-mail: chemanal@pg.gda.pl

The presence of some heavy metals in ecosystems (including seas and oceans) can have deleterious effects because:

- they do not degrade and have long half-lives
- they may bioaccumulate in living tissues, giving rise to symptoms of toxicity [4]

Heavy metals are poorly soluble in water, tending to adsorb onto suspended particulate matter in the sea, and affect marine organisms. Toxic effects do not normally manifest themselves immediately after the toxin enters the environment and organisms; they usually become apparent only after a few years [5]. The duration of an organism's exposure to heavy metals has a significant effect on their bioaccumulation; sometimes, despite a relatively short exposure period, the amount of a metal deposited in an organism may be considerable [6].

The processes by which metals accumulate in the tissues and organs of living organisms are species-dependent and are related to the mechanisms of detoxification and metabolism. As a consequence, we may find a variety of organisms from the same environment having different levels of metals [7-9]. The accumulation of heavy metals at different levels of the trophic pyramid causes serious problems as far as the health of the marine environment is concerned. In these circumstances, the selection of suitable species that could be an indicator [10] of xenobiotic accumulation in the tissues and organs of plant and animals at various levels of the trophic pyramid takes on a particular significance. The use of indicator species should help to acquire:

- a more reliable assessment of the risks of exposure
- an understanding of the mechanisms of bioaccumulation and detoxification

Accumulation of Metals in Tissues and Organs of Marine Organisms

Many xenobiotics, also heavy metals, are accumulated in the organism. Some of them are quickly detoxified, but the vast majority is stored in tissues and organs. The bioconcentration and bioaccumulation factors and trophic transfer factor are measure the levels of metals retained in an organism.

Bioconcentration is the process, a result of which is the concentration of contaminants in an organism that is higher than in the surrounding environment. This term is also applicable to an organism studied under laboratory conditions, where a xenobiotic enters via the respiratory pathways or the skin. This process is characterized by the bioconcentration factor (BCF), i.e. the ratio of the concentration of a metal in an organism to its concentration in water [11, 12].

In contrast, the bioaccumulation factor (BAF) differs from BCF in that the xenobiotic concentration is the total amount of contaminant that has entered the organism by all possible pathways, i.e. via food intake, respiratory pathways, penetration through the skin, etc. [11].

It happens that the level of a metal in the tissues of one organism does not elicit any toxic effect at all, but may con-

stitute a danger to its predators. The concentration of a metal in the tissues of a predator may be higher (bioaccumulation) or lower (biodilution) than in the tissues of its victims [11]. The bioaccumulation of a metal resulting from the consumption of other organisms is characterized by the trophic transfer factor (TTF), i.e. the ratio of the concentration of a metal in an organism (predator) to its concentration in the food that organism consumes. The TTF is useful for assessing the extent to which a metal has been transferred from an organism on a lower trophic level to an organism on a higher one.

The Effect of Metals on Marine Organisms

Marine ecosystems are exposed to a great variety of contaminants, among them heavy metals. As some of these can remain in the environment for a long time, they may affect organisms in the food chain as a consequence. Sometimes the presence of xenobiotics causes so great a change in the environment that a return to earlier, natural conditions is impossible. Anthropopressure on the sea's resources is increasing: among other things, it affects the health of many organisms, leading to changes in the food web structure and influencing bioaccumulation in the tissues of marine plants and animals [13].

Heavy metals affect living organisms even when their environmental concentrations are small. Their harmfulness is due not only to the degree of contamination of the environment, but also to the biochemical role in metabolic processes and the extent to which they are absorbed and excreted by marine organisms.

Table 1 lists information on the role of heavy metals in the life processes of organisms in different parts of the sea's trophic pyramid. Excessive concentrations of some toxic metals can lead to dysfunction of the endocrine system, of reproduction, and growth [13]. Moreover, those metals that can be accumulated in the tissues and organs of organisms may adversely affect cellular functions by interacting with systemic enzymes. This can lead to disturbances of growth, reproduction, the immune system, and metabolism.

Zinc is of major importance in metabolic processes, because it is a constituent of haemocyanin in molluscs; hence, the level of this element will be higher [65]. In particular, snails of the genus *Patella* take up large amounts of Zn [14], which is an essential element ensuring the proper functioning of many enzymes and other compounds of crucial significance in metabolism. Moreover, snails also have a high content of iron [65], a constituent of goethite (α -FeOOH). This compound is responsible for the proper functioning of the radula [14].

Unlike zinc, copper is a constituent of haemocyanin in crustaceans. In addition, zinc and copper levels are regulated by metabolic processes or homeostasis [15, 16], and their levels can be affected by numerous factors, including short-term starvation [17]. That these two elements are correlated can be explained by the fact that they are bound by metallothionein (MT), a compound of great significance in homeostasis and in the binding and release of metals [18].

Table 1. The role of heavy metals and their influence on marine organisms.

Sub-phyllum	Class (example organisms)	The role and influence of heavy metals										References
		Cu	Cd	Zn	Hg	Pb	Other metals	Additional information				
Invertebrates	Molluscs (oysters, marine snails, nautili, octopuses, bivalves)	Regulated metabolically; constituent of enzymes and haemocyanin in some animals; constituent of respiratory pigment; in large amounts may cause peroxidation of lipids and the formation of DNA adducts	In large amounts may cause peroxidation of lipids and the formation of DNA adducts	Level regulated metabolically; constituent of many enzymes (e.g. proteolytic) and haemocyanin in some animals, and of respiratory pigment	In large amounts may cause peroxidation of lipids and the formation of DNA adducts; affects cell metabolism		Mn: constituent of many enzymes, metalloenzymes and respiratory pigment	Pb, Cd, Hg, As, Se, Sb (applies to all organisms): attack bonds with sulphur, carboxylic and amine groups of proteins in enzymes; remove phosphate from compounds or catalyse their decomposition; elicit redox reactions generating reactive forms of oxygen (RFT), like the oxygen radical anion O ₂ ⁻ ; hydrogen peroxide (H ₂ O ₂), hydroxyl radical (OH), singlet oxygen (O ₂), etc.	8, 9, 33-41, 65			
	Crustaceans (copepods, prawns, lobsters, crabs)	Enhanced Cd uptake occurs as a result of the lack of selectivity in Cu absorption; if there is a deficit of Cu, Cd uptake takes place	Constituent of many enzymes; participates in many enzymatic and metabolic processes						8, 9, 16, 29, 35-42, 65			
	Echinoderms (starfish)	Constituent of many enzymes; takes part in biological reactions	Participates in enzymatic reactions							8, 9, 16, 35, 40, 41		
Vertebrates	Fish (swordfish, tuna, dolphin-fish, gilthead seabream, mullet, sardine, herring, sprat, cod, unicorn icefish)	Constituent of many enzymes; regulated metabolically	May lead to exhaustion, dysfunction of coordination, loss of appetite; death; adversely affects the central nervous system and endocrine system, and leads to dysfunction of reproduction, osmoregulation, orientation, prey location and interspecific communication; fat-soluble methylmercury (MeHg) is formed and is absorbed along similar pathways as organochlorine compounds like DDT				Causes behavioural disturbances; affects survival, growth, learning and metabolism; the inorganic compounds of Pb are carcinogenic	Se: assists in the removal of Hg from the system (as in birds)	20, 40, 41, 43-45			

Links in the food chain in marine ecosystems



Table 1. Continued.

		The role and influence of heavy metals								References
Sub- phylum	Class (example organisms)	Cu	Cd	Zn	Hg	Pb	Other metals	Additional information		
Vertebrates	Birds (auk, gadfly petrel, shearwater, gull, avocet, tern, cormorant)	Constituent of many enzymes; metabolically regulated; bound by eumelanin (pigment) in feathers, accumulated in feathers because of strong affinity for the thiol (SH) group of keratin; evenly distributed in the tissues of young birds; accumulates with age owing to the strong affinity for MT; excess removed during moulting	Accumulates with age owing to the affinity for MT	Bound by eumelanin (pigment) in feathers; constituent of many enzymes regulated metabolically	The strong affinity for the thiol (SH) group in keratin leads to accumulation in feathers; adversely affects the central nervous system and endocrine system, and leads to dysfunction of reproduction, osmoregulation, orientation, prey location and interspecific communication; accumulates with age owing to the strong affinity for MT removed during moulting; fat-soluble methylmercury (MeHg) is formed, and is absorbed along similar pathways as organochlorine compounds like DDT	The strong affinity for the thiol (SH) group in keratin leads to accumulation in feathers; causes behavioural disturbances; affects survival, growth, learning and metabolism; the inorganic compounds of Pb are carcinogenic	Se: participates in the demethylation of MeHg and in the removal of Hg from the system by the formation of the non-toxic mercury selenide (HgSe); selenium assists the formation and utilization of glutathione, which acts as an antioxidant and offers protection against free radicals; Mn: constituent of many enzymes regulated metabolically	Relationship between Zn-Cu-Hg: similar pathways of the metabolism and storage of these metals; relationship between Se-As and Se-Cr in the kidneys: Se plays a major part in the storage and detoxification of As and Cr	18, 20, 22-24, 30, 38, 40, 41, 43-47, 65	
	Reptiles (green sea turtle, loggerhead sea turtle, hawksbill sea turtle, olive ridley sea turtle)		May adversely affect DNA, RNA, ribosome synthesis, and may deactivate many systemic enzymes; has teratogenic and embryotoxic properties; chronic exposure may disrupt reproductive processes, as well as oestrogenic, anti-oestrogenic and endocrine reactions		Adversely affects the central nervous system and endocrine system, and leads to dysfunction of reproduction, osmoregulation, orientation, prey location and interspecific communication; accumulates with age owing to the strong affinity for MT; removed during moulting; fat-soluble methylmercury (MeHg) is formed, and is absorbed along similar pathways as organochlorine compounds like DDT	Causes behavioural disturbances; affects survival, growth, learning and metabolism; the inorganic compounds of Pb are carcinogenic	As: inorganic compounds of As are toxic – they increase the risk of cancer of the lungs, skin, liver, kidneys and urinary bladder; these compounds increase the quantities of lipid peroxides and free radicals formed; they reduce Se levels; organic compounds of As (e.g. arsenobetaine, dimethylarsinic acid (DMA)) may have toxic effects, e.g. DNA may be destroyed by free radicals (like dimethylarsinic peroxide), which are metabolites of DME (DMA) or dimethylarsine. Ni: causes mortality; retards the animal's rate of growth; the toxicity of Ni increases in the presence of Cu. Se: takes part in the removal of Hg from the body (as in birds)		8, 9, 24, 29, 32, 35, 40-45, 48-51	
	Mammals (fur seal, Risso dolphin, striped dolphin, blue whale, bowhead whale, grey whale)	Regulated by homeostasis; a high Cu level may slow down Na ⁺ /K ⁺ -ATPase in the cell membrane and may restrict potassium regulation and osmotic equilibrium; the Cu level may affect the absorption of other metals		Regulated by homeostasis; offers protection against UV light, which destroys DNA	Regulated by homeostasis; similar pathways as organochlorine compounds like DDT		Se: offers protection against UV light, which destroys DNA; takes part in the removal of Hg from the body (as in birds)		8, 9, 16, 18, 24, 30, 35-41, 44, 45, 65	

Links in the food chain in marine ecosystems

Mercury is highly toxic to many organisms, even at low concentrations. The level of Hg will usually be higher in the liver, as this is the organ responsible for detoxification [19]. Sea birds are more resistant to the effects of Hg because of the detoxification afforded by their moulting cycles, the induction of the synthesis and binding to metallothioneins, as well as demethylation and the formation of a Se-Hg complex [20]. The Hg level also depends on the organism's sex: Hg levels are lower in females because they are able to transfer MeHg from soft tissues to the eggs [21]. The higher levels of Hg and Cd are due to their long half-lives, their abilities to bind to MT, and difficulties in removing them from the organism. More than 90% Hg can be removed during moulting, but once this process is complete, metal levels in the tissues again begin to rise as a result of accumulation [20]. Mercury, copper and lead are accumulated in the feathers [22, 23], so these can be used as bioindicators [21, 24]. Female birds are capable of excreting metals from the organisms via feathers (Hg, Sb, Ag, Pb) or eggs (Tl, Sr, Ba, Se, Co) [23]. Only small amounts of cadmium and lead are removed by the eggs, and almost all the Cd is retained in the system.

Interpretation of information about Hg levels in organs is difficult, because mercury can undergo methylation [19]. Moreover, selenium can react with MeHg in the liver, which makes Se an important element participating in demethylation [25]. In order to obtain true and accurate information about the level of contamination of an animal's tissues, one would have to determine, for example, the total content of mercury (THg), and the levels of methyl mercury (MeHg) and selenium [19, 26]. MeHg is particularly dangerous, as it accumulates in the tissues, and its concentration rises with every level of the trophic pyramid. It is also believed that the bacteria present in anoxic near-bottom waters play a key role in the transport of Hg in the food chain [21].

Lead is an element eliciting a range of toxic effects. Blood and haematocrit levels of Pb, as well as enzymatic tests, may indicate that animals are being exposed to this metal [27]. Actually, there are no data available regarding toxic levels of Pb. But there are reports that lead concentrations of 10 µg/g d.wt. in the liver give rise to subclinical effects. It is also known that such levels of lead in mammalian livers are tantamount to acute poisoning [28].

Cadmium is bioaccumulated in tissues and is excreted to only a small extent [29]. Cd has a very long half-life (>10 years in terrestrial mammals) and is detoxified by being bound to metallothioneins (MT). Moreover, a Cd-Se complex has been discovered (as in the case of mercury), suggesting the formation of a selenium metabolite [30]. Cd absorption is not controlled by active homeostasis, so the presence of this metal in tissues may be indicative of both short- and long-term exposure. The decomposition of metals in tissues depends on both the duration of exposure and the concentration of the element in the immediate environment. The liver is the organ in which cadmium is stored in the short term, but should exposure be chronic, cadmium is transferred from the liver to the kidneys, where it is absorbed and bioaccumulated. This happens because Cd

forms a complex with metallothionein (MT) [29, 31, 32]. It is conjectured that such a metal-metallothionein complex stops the metal from being harmless [31].

Arsenic is also toxic to marine organisms. Di- and trimethylated arsenosugars have been found in algae. Arsenic levels in the tissues of marine animals are similar to those in algae. Apart from arsenobetaine, arsenic may be present in the form of the tetramethylarsonium ion, trimethylarsinic oxide, or arsenic-containing ribosides [51]. The inorganic compounds of arsenic are toxic, but the organic compounds of this element (including arsenosugars and arsenobetaine), even though less poisonous, are often present in relatively high concentrations in marine organisms [52]. But arsenobetaine and dimethylarsinic acid can also elicit toxic effects. The bioaccumulation of arsenic is more intensive at lower levels of the trophic pyramid in marine ecosystems. Interestingly, arsenic concentrations in higher organisms, like turtles, are at much the same levels as in lower organisms. There are two different explanations for this: one assumes that their preys contain large amounts of arsenic; the other claims that because metabolic processes in different species are different, arsenic, too, is variously metabolized [51].

Vertebrates use a variety of homeostasis strategies to limit the accumulation of metals that could elicit toxic effects. In the metabolism of these animals it is the liver that plays the key part, as it is the site not only of the bioaccumulation of metals, but also their biotransformation, detoxification and enhanced elimination [53, 54]. In this organ, also large amounts of metallothionein are detected, induced in the organisms at the moment when heavy metals penetrate them [10, 53, 55].

The Role of Metallothionein (MT) in the Bioaccumulation of Metals in the Tissues of Marine Organisms

The formation of metallothionein (MT) in response to the presence of metals eliciting toxic effects was recognized as being of major significance already at the moment of its discovery [56-58]. MT is a cysteine-rich, low-molecular weight protein whose cysteine residues take part in the coordination of metals that are of great significance for the structure and function of this protein [57, 58]. Even though the metal complex with MT is very stable, it is associated with a dynamic inter- and intra-protein exchange of metal [57].

The exact cellular functions of MT are not known, but evidence suggests that this protein plays a special part in regulating the intracellular availability of metals like copper, zinc, and cadmium [56, 57]. MTs are capable of transporting copper and zinc to receptors like metalloenzymes [59] or transcription factors [60], and regulate metal-dependent activities by means of highly specific intermolecular interactions. The binding by MT of both physiological and xenobiotic metals in an organism protects it from the toxic effects of those metals that would occur if they became bound to proteins or enzymes with important functions in



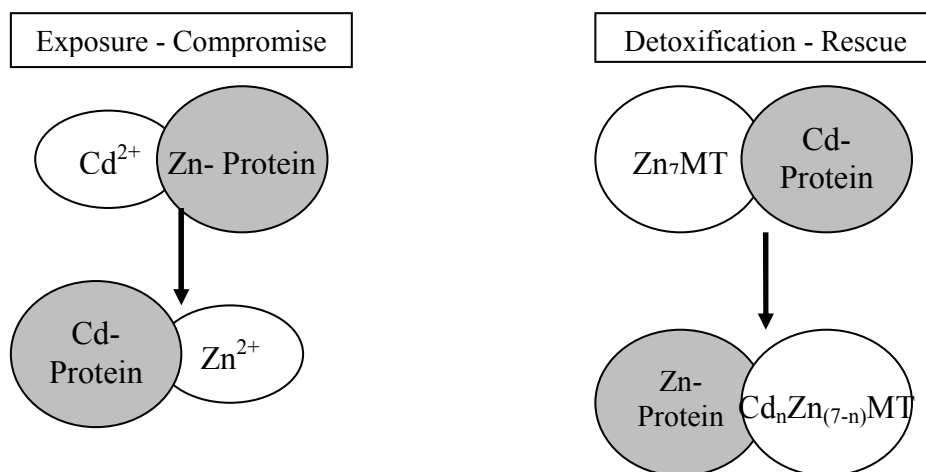

Fig. 1. Schematic representation of the intracellular detoxification mechanism involving ZnMT [57].

metabolic or enzymatic processes. The compound providing a lifeline (detoxicant) to proteins previously bound to a toxic metal like cadmium is ZnMT (Fig. 1), a Cd receptor. This zinc metalloprotein, a Zn donor, has become the main substance participating in the mechanism that restores proper functions [57]. The processes increasing capacity for MT synthesis, e.g. induction, gene replication, and gene duplication, impart the cell or individual organism with an enhanced resistance to the toxic effects of metals. In yeast, for example, resistance to copper poisoning is minimal when the endogenous MT gene is first removed and then restored at the moment it is displaced by the homologue [56, 57]. The existence of specific transcription factors for the expression of genes responsible for the metal activation is proof that MT induction is a specific response of the cell to changes in metal concentration [56, 61].

MT induction is a distinctive process whose mechanism depends on which metal is eliciting it [57, 61]. The presence of metal regulatory elements (MRE) in the counter-current gene sequence in MT is indicative of the specificity of induction. MT induction and the consequent enhanced

level of metal binding by MT provided the first evidence that detoxification was possible. The binding of cadmium by non-thionein ligands leads to toxicity, but binding with MT protects non-thionein structures by reducing the rate of cadmium uptake [57]. There is a fair amount of evidence in the literature suggesting that short-term exposure to low levels of metals like Cd or Hg may guarantee immunity against toxic concentrations. In cell cultures exposure may lead to replication of the MT gene and of cells resistant to metals [62]. Duplication of the MT gene (a fragment of the chromosome is doubled as a result of the non-symmetrical exchange of chromatid sections) in healthy animals is associated with the evolution of a population resistant to metals [57].

The amino acid sequences in various species, including aquatic animals, display a certain similarity. Protected nucleotide sequences exist in regions coding that regulates the MT level in mammals, fish, and invertebrates [49, 56, 63]. Biochemical procedures and DNA recombination technologies have facilitated the determination of metallothionein and the expression of genes coding MT.

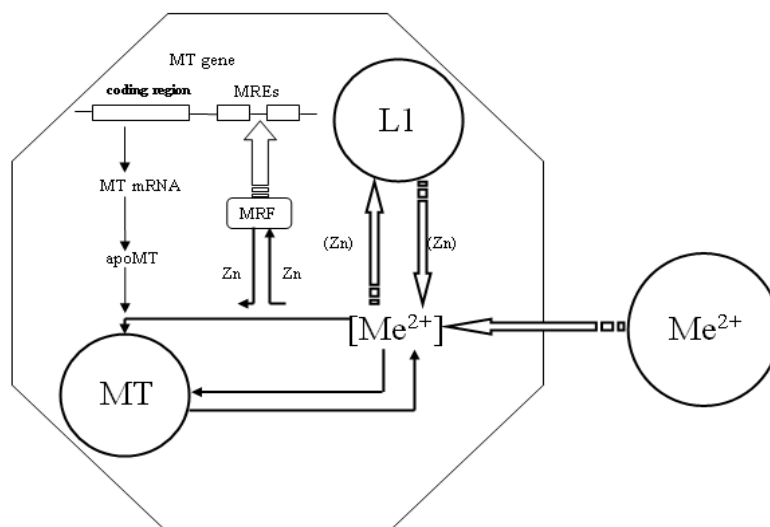

Fig. 2. Diagram showing the intracellular metal distribution pathways in relation to MT induction [56]. L1 – intracellular binding site, MRE – metal regulatory element, MRF – metal regulatory factor.

Methodologies employing FPLC (in the case of fish) and HPLC (in the case of invertebrates) have led to the discovery of many MT structures in a single sample. Studies at the molecular level have given us a better understanding of the structure of MT and its expression [56, 64]. These results have undoubtedly enhanced our knowledge of the functions of MT in aquatic animals and will enable MT to be used as a biomarker of the exposure of organisms to metals.

In the cellular model of MT induction (Fig. 2), expression of the MT gene in aquatic species may occur at the level of transcription or of translation. Information about the increasing metal content in the cell is transmitted to metallothionein by the MT gene responsible for activating the transcription factors that initiate expression in order for it to bind to the metal. This gives rise to the next step in the transcription and synthesis of apothioneins and, in consequence, the binding of these last with metals ions to the form of MT. MT induction can be measured as the concentration or rate of formation of the relevant mRNA, MT, and the level of metals bound to MT [61, 56].

The presence of metal regulatory elements (MRE) in the MT gene sequence provides confirmation of the specific induction of MT by metals [61]. Investigations have shown that metal regulatory factors (MRF) initiate MT gene expression. However, the mechanism regulating transcription appears to differ in lower and higher eukaryotes. In yeast, activation by metals of the transcription factor gives rise to conformational changes, which leads to interaction with the relevant MREs and initiates gene expression [57]. In higher organisms MT gene expression is regulated by Zn, which is an inhibitor bound to the active transcription factor under non-induced conditions. Other MT-inducing metals, like Cd, Cu, or Hg, do not directly activate MRFs.

The induction of MT by other metals causes the intracellular concentration of free zinc to increase. Cadmium, copper, and mercury display a greater affinity for ligands than zinc, and will probably displace zinc from its binding sites. The liberated zinc may then bind with the inhibitor, thus releasing the transcription factor from the inhibitor and initiating MT expression. Structures from which Zn has been displaced are candidates for detoxification by the newly formed ZnMT.

To a certain extent bioaccumulation in tissues is a function of the decomposition and induction of specific metal-binding proteins like metallothionein. MT is synthesized in response to the presence of essential and inessential metals [56, 58]. Moreover, a correlation has been found between exposure to cadmium and MT induction in the livers of various non-mammalian animals. This is why MT has been acknowledged as a biomarker for assessing the effects of exposure to heavy metals. Be that as it may, few studies have been carried out on MT induction in tissues other than the liver or kidneys [29, 58, 57].

In the case of mammals, the first response to toxic Cd concentrations is observed in the liver. It has been suggested that the complex Cd-MT is released from the liver and captured by the kidneys, where long-term storage ensues. Furthermore, MT induction in the kernels and oviducts could be indicative of potential endocrine dysfunction [29].

In principle, toxic metals inhibit cellular enzyme activity in that physiological metals (Cu, Zn, Ca) are displaced by xenobiotic ones (Cd, Pb, Hg). Also, in fish MT is responsible for one of the detoxification pathways. It affords protection against the deleterious effects of some metals, particularly cadmium, by exchanging or reducing the numbers of free ions; these activities provide a lifeline to structures weakened by inappropriate metal bonding. MT is present mainly in the liver, kidneys, gills and muscles. Apart from having a high affinity for Cd, MT also binds Ag, Cu, Hg, and Zn. Metallothionein can act as an absorber of toxic metals (like Cd and Hg) or an excess of metals (like Cu and Zn).

Conclusions

Heavy metals contribute to marine pollution. On the one hand, they do not decompose, and on the other they bioaccumulate in the tissues and organs of marine organisms. Toxic elements often give rise to undesirable effects in organisms at different levels of the trophic web and perturb the functions fulfilled by essential metals. Some metals, like Zn or Cu, are constituents of enzymes and haemocyanin, indispensable for the proper functioning of metabolic processes. Other metals, like Cd, Ni, Hg, or Pb, elicit adverse effects such as behavioral and endocrine disturbances, and high levels can be lethal. Selenium is a crucial element as it helps to remove metals such as mercury and cadmium from the system. The bioaccumulation of metals can be described by factors describing the retention of metals, i.e. the bioconcentration factor (BCF), bioaccumulation factor (BAF), and the trophic transfer factor (TTF).

Appearing in response to the presence of toxic metals, metallothionein plays an important role in the system by regulating the intracellular availability of metals. MT's mechanism of action depends on the intra- and inter-protein exchange of metals. MT affords protection against the toxic effects induced by such metals as Cd, Cu, or Hg.

References

1. PRUDENTE M., KIM E. Y., TANABE S., TATSUKAWA R. Metal levels in some commercial fish species from Manila Bay, the Philippines, *Mar. Poll. Bull.*, **34**, 671, **1997**.
2. DUFFUS J. H. Heavy metals – a meaningless term, *Pre Appl. Chem.*, **74**, 763, **2002**.
3. KHALED A. Heavy metal concentrations in certain tissues of five commercially important fishes from El-Mex Bay, Alexandria, Egypt, *Egyptian Journal of Aquatic Biology And Fisheries*, **8**, 51, **2004**.
4. FRAZIER J. M. Bioaccumulation of cadmium in marine organisms, *Environ. Health Perspectives*, **28**, 75, **1979**.
5. DANIS B., WANTIER P., FLAMMANG R., PERNET PH., CHAMBOST-MANCIET Y., COTEUR G., WARNAU M., DUBOIS PH. Bioaccumulation and effects of PCBs and heavy metals in sea stars (*Asterias rubens*, L.) from the North Sea: a small scale perspective, *Sci. Tot. Environ.* **356**, 275, **2006**.



6. RADENAC G., FICHET D., MIRAMAND P. Bioaccumulation and toxicity of four dissolved metals in *Paracentrotus lividus* sea-urchin embryo, *Marine Environ. Research*, **51**, 151, **2000**.
7. RITTERHOFF J., ZAUKE G. P. Trace metals in field samples of zooplankton from the Fram Strait and the Greenland, *Sea. Sci. Total Environ.*, **199**, 255, **1997**.
8. KAHLE J., ZAUKE G. P. Trace metals in Antarctic copepods from the Weddell Sea (Antarctica), *Chemosphere*, **51**, 409, **2003**.
9. PROWE F., KIRF M., ZAUKE G. P. Heavy metals in crustaceans from the Iberian deep sea plain, *Sci. Mar.*, **70**, 271, **2006**.
10. RIBEIRO A. R., EIRA C., TORRES J., MENDES P., MIQUEL J., SOARES A. M. V. M., VINGADA J. Toxic element concentrations in the razorbill *Alca torda* (Charadriiformes, Alcidae) in Portugal, *Arch. Environ. Contam. Toxicol.*, **56**, 588, **2009**.
11. DEFOREST D. K., BRIX K. V., ADAMS W. J. Assessing metal bioaccumulation in aquatic environments: the inverse relationship between bioaccumulation factors, trophic transfer factors and exposure concentration, *Aquatic Toxicology*, **84**, 236, **2007**.
12. SHUN-XING L., HUA-SHENG H., FENG-YING Z., NAN-SHENG D., FANG L. Influence of nitrate on metal sorption and bioaccumulation in marine phytoplankton, *Dunaliella salina*, *Experimental Toxicology*, **22**, 582, **2007**.
13. HYLLAND K. Biological effects in the management of chemicals in the marine environment, *Mar. Pollut. Bull.*, **53**, 614, **2006**.
14. CRAVO A., BEBIANNO M. J. Bioaccumulation of metals in the soft tissue of *Patella aspera*: Application of metal/shell weight indices, *Estuarine, Coastal and Shelf Science*, **65**, 571, **2005**.
15. MONACI F., BORREL A., LEONZIO C., MARSILI L., CALZADA N. Trace elements in striped dolphins (*Stenella coeruleoalba*) from the western Mediterranean, *Environ. Poll.*, **99**, 61, **1998**.
16. MENDEZ L., ALVAREZ-CASTANEDA S. T., ACOSTA B., SIERRA-BELTRAN A. P. Trace metals in tissues of gray whale (*Eschrichtius robustus*) carcasses from the Northern Pacific Mexican Coast, *Mar. Poll. Bull.*, **44**, 217, **2002**.
17. DEBACKER V., JAUNIAUX T., COIGNOUL F., BOUQUEGNEAU J. M. Heavy metals contamination and body condition of wintering guillemots (*Uria aalge*) at the Belgian coast from 1993 to 1998, *Environ. Res.*, **84**, 310, **2000**.
18. KRONE C. A., ROBISCH P. A., TILBURY K. L., STEIN J. E. Elements in liver tissues of bowhead whales (*Balaena mysticetus*), *Mar. Mam. Sci.*, **15**, 123, **1999**.
19. EAGLES-SMITH C. A., ACKERMAN J. T., ADELSBACH T. L., TAKEKAWA J. Y., MILES A. K., KEISTER R. A. Mercury correlation among six tissues for four water-bird species breeding in San Francisco Bay, California, USA, *Environ. Toxicol. Chem.*, **27**, 2136, **2008**.
20. RIBEIRO A. R., EIRA C., TORRES J., MENDES P., MIQUEL J., SOARES A. M. V. M., VINGADA J. Toxic element concentrations in the razorbill *Alca torda* (Charadriiformes, Alcidae) in Portugal, *Arch. Environ. Contam. Toxicol.*, **56**, 588, **2009**.
21. FURNESS R. W., CAMPHUYSEN K. C. J. Seabirds as monitors of the marine environment, *J. Mar. Sci.*, **54**, 726, **1997**.
22. BURGER J., NISBET I. C. T., GOCHFELD M. Heavy metal and selenium levels in feathers of known-aged common terns (*Sterna hirundo*), *Arch. Environ. Contam. Toxicol.*, **26**, 351, **1994**.
23. AGUSA T., MATSUMOTO T., IKEMOTO T., ANAN Y., KUBOTA R., YASUNAGA G., KUNITO T., TANABE S., OGI H., SHIBATA Y. Body distribution of trace elements in black-tailed gulls from Rishiri Island, Japan: age-dependent accumulation and transfer to feathers and eggs, *Environ. Toxicol. Chem.*, **24**, 2107, **2005**.
24. BURGER J., GOCHFELD M. Marine birds as sentinels of environmental pollution, *Ecohealth*, **1**, 263, **2004**.
25. KIM E. Y., MURAKAMI T., SAEKI K., TATSUKAWA R. Mercury levels and its chemical form in tissues and organs of seabirds, *Arch. Environ. Contam. Toxicol.*, **30**, 259, **1996**.
26. SCHEUHAMMER A. M., BASU N., BURGESS N. M., ELLIOT J. T., CAMPBELL G. D., WAYLAND M., CHAMPOUX L., RODRIGUE J. Relationships among mercury, selenium, and neurochemical parameters in common loons (*Gavia immer*) and bald eagles (*Haliaeetus leucocephalus*), *Ecotoxicology*, **17**, 93, **2008**.
27. BURGER J., GOCHFELD M. Metal levels in eggs of common terns (*Sterna hirundo*) in New Jersey: temporal trends from 1971 to 2002, *Environ. Res.*, **94**, 336, **2004**.
28. GODLEY B. J., THOMPSON D. R., FURNESS R. W. Do heavy metal concentrations pose a threat to marine turtles from the Mediterranean Sea?, *Mar. Poll. Bull.*, **38**, 497, **1999**.
29. RIE M. T., LENDAS K. A., CALLARD I. P. Cadmium: tissue distribution and binding protein induction in the painted turtle, *Chrysemys picta*, *Comparat. Biochem. Physiol Part C*, **130**, 41, **2001**.
30. ARAI T., IKEMOTO T., HOKURA A., TERADA Y., KUNITO T., TANABE S., NAKAI I. Chemical forms of mercury and cadmium accumulated in marine mammals and seabirds as determined by XAFS analysis, *Environ. Sci. Technol.*, **38**, 6468, **2004**.
31. GARDNER S. C., FITZGERALD S. L., VERGAS B. A., RODRIGUEZ L. M. Heavy metal accumulation in four species of sea turtles from the Baja California peninsula, Mexico, *BioMetals*, **19**, 91, **2006**.
32. BARBIERI E. Concentration of heavy metals in tissues of green turtles (*Chelonia mydas*) sampled in the Cananea estuary, Brazil, *Brazil. Journ. Oceanogr.*, **57**, 243, **2009**.
33. NESTO N., ROMANO S., MOSCHINO V., MAURI M., DA ROS L. Bioaccumulation and biomarker responses of trace metals and micro-organic pollutants in mussels and fish from the Lagoon of Venice, Italy, *Mar. Poll. Bull.*, **55**, 469, **2007**.
34. BUSTAMANTE P., GRIGIONI S., BOUCHER-RODONI R., CAURANT F., MIRAMAND P. Bioaccumulation of 12 trace elements in the tissues of the nautilus *Nautilus macromphalus* from New Caledonia, *Marine Poll. Bull.*, **40**, 688, **2000**.
35. PETRI G., ZAUKE G. P. Trace metals in crustaceans in the Antarctic Ocean, *Ambio*, **22**, 529, **1993**.
36. JECKEL W. H., ROTH R. R., RICCI L. Patterns of trace-metal distribution in tissues of *Pleoticus muelleri* (Crustacea: Decapoda: Solenoceridea), *Mar. Biol.*, **125**, 297, **1996**.
37. TEMARA A., WARNAU M., JANGOUX M., DUBOIS PH. Factors influencing the concentrations of heavy metals in the asteroid *Asterias rubens* L. (Echinodermata), *Sci. Total. Environ.*, **203**, 51, **1997**.

38. KUNITO T., WATANABE I., YASUNAGA G., FUJISE Y., TANABE S. Using trace elements in skin to discriminate the populations of minke whales in the southern hemisphere, *Mar. Environ. Res.*, **53**, 175, **2002**.
39. ZAUKE G. P., KRAUSE M., WEBER A. Trace metals in mesozooplankton of the North Sea: Concentrations in different taxa and preliminary results on bioaccumulation in copepod collectives (*Calanus finmarchicus*/*C. helgolandicus*), *Int. Revue Ges. Hydrobiol.*, **81**, 141, **1996**.
40. AL-MOHANNA S. Y., SUBRAHMANYAM M. N. V. Flux of heavy metal accumulation in various organs of the intertidal marine blue crab, *Portunus pelagicus* (L.) from the Kuwait coast after the Gulf War, *Environ. Internat.*, **27**, 321, **2001**.
41. HUANG W., CAO L., YE Z., YIN X., DOU SH. Antioxidative responses and bioaccumulation in Japanese flounder larvae and juveniles under chronic mercury exposure, *Comparative Biochemistry and Physiology*, **152**, 99, **2010**.
42. DOI R., CHOWDHURY P., NISHIKAWA M., Rayford P. L. Tissue distribution of cadmium-109 after tracheal and gastric administration in rats, *Bull. Environ. Contam. Toxicol.*, **51**, 619, **1993**.
43. WEBER D. N., DINGEL W. M. Alterations in neurobehavioral responses in fishes exposed to lead and lead-chelating agents, *Am. Zool.*, **37**, 354, **1997**.
44. BURGER J., GOCHFELD M. Effects of lead on birds (Laridae): a review of laboratory and field studies, *J. Toxicol. Environ. Health*, **3**, 59, **2000**.
45. COELHO J. P., SANTOS H., REIS A. T., FALCAO J., RODRIGUES E. T., PEREIRA M. E., DUARTE A. C., PARDAL M. A. Mercury bioaccumulation in the spotted dogfish (*Scyliorhinus canicula*) from the Atlantic Ocean, *Mar. Poll. Bull.*, **60**, 1372, **2010**.
46. LANGSTON W. J., CHESMAN B. S., BURT G. R., POPE N. D., MCEVOY J. Metallothionein in liver of eels *Anguilla anguilla* from the Thames Estuary: an indicator of environmental quality?, *Mar. Environ. Res.*, **53**, 263, **2002**.
47. NIECKE M., HEID M., KRUGER A. Correlations between melanin pigmentation and element concentration in feathers of white-tailed eagles (*Haliaeetus albicilla*), *J. Ornithol.*, **140**, 355, **1999**.
48. HAN B. C., JENG W. L., CHEN R. Y., FANG G. T., HUNG T. C., TSENG R. J. Estimation of target hazard quotients and potential health risks for metals by consumption of seafood in Taiwan, *Arch. Environ. Contam. Toxicol.*, **35**, 711, **1998**.
49. HARLOW P., WATKINS E., THORNTON R. D., NEMER M. Structure of an ectodermally expressed sea urchin metallothionein gene and characterization of its metal-responsive region, *Mol. Cell. Biol.*, **9**, 5445, **1989**.
50. CHIOU H. Y., HUNG W. I., SU C. L., CHANG S. F., HSU Y. H., CHEN C. J. Dose-response relationship between prevalence of cerebrovascular disease and ingested inorganic arsenic, *Stroke*, **28**, 1717, **1997**.
51. SAEKI K., SAKAIBARA H., SAKAI H., KUNITO T., TANABE S. Arsenic accumulation in three species of sea turtles, *BioMetals*, **13**, 241, **2000**.
52. LAM J. C. W., TANABE S., CHAN S. K. F., YUEN E. K. W., LAM M. H. W., LAM P. K. S., Trace element residues in tissues of green turtles (*Chelonia mydas*) from South China Waters, *Mar. Poll. Bull.*, **48**, 164, **2004**.
53. FERNANDES C., FONTAINHAS-FERNANDES A., PEIXOTO F., SALGADO M. A. Bioaccumulation of heavy metals in *Liza saliens* from the Esmoriz-Paramos coastal lagoon, Portugal, *Ecotox. Environ. Safety*, **66**, 426, **2007**.
54. TRIEBSKORN R., KOHLER H. R., HONNEN W., SCHRAMM M., ADAMS S. M. Induction of heat shock proteins, changes in liver ultra-structure, and alterations of fish behaviour: are these biomarkers related and are they useful to reflect the state of pollution in the field?, *J. Aquat. Ecosyst. Stress Recov.*, **6**, 57, **1997**.
55. OLSVIK P. A., GUNDERSEN P., ANDERSEN R. A., ZACHARIASSEN K. E. Metal accumulation and metallothionein in brown trout, *Salmo trutta*, from two Norwegian rivers differently contaminated with Cd, Cu and Zn, *Comp. Biochem. Physiol. Part C.*, **128**, 189, **2001**.
56. ROESIJADI G. Metallothionein induction as a measure of response to metal exposure in aquatic animals, *Environ. Health Perspect.*, **102**, 91, **1994**.
57. ROESIJADI G. Metallothionein and its role in toxic metal regulation, *Comp. Biochem. Physiol.*, **113**, 117, **1996**.
58. KAGI J. H. R., VALLEE B. L. Metallothionein: a cadmium- and zinc-containing protein from equine renal cortex, *J. Biol. Chem.*, **235**, 3460, **1961**.
59. UDOM U. O., BRADY F. O. Reactivation in vitro of zinc-requiring apo-enzymes by rat liver zinc-thionein, *J. Biochem.*, **187**, 329, **1980**.
60. ZENG J., VALLEE B. L., KAGI J. H. R. Zinc transfer from transcription factor IIIA fingers to thionein clusters, *Proc. Natl. Acad. Sci. USA*, **88**, 9984, **1991**.
61. THIELE D. J. Metal-regulated transcription in eukaryotes, *Nucleic Acids Res.*, **20**, 1183, **1992**.
62. BEACH L. R., PALMITER R. D. Amplification of the metallothionein-I gene in cadmium-resistant mouse cells, *Proc. Natl. Acad. Sci. USA*, **78**, 2110, **1981**.
63. OTTO E., ALLEN J. M., YOUNG J. E., PALMITER R. D., MARONI G. A DNA segment controlling metal-regulated expression of the *Drosophila melanogaster* metallothionein gene Mtn., *Mol. Cell. Biol.*, **7**, 1710, **1987**.
64. IMBERT J., ZAFARULLAH M., CULOTTA V. C., GEDAMU L., HAMER D. Transcription factor MBF-1 interacts with metal regulatory elements of higher eukaryotic metallothionein genes, *Mol. Cell. Biol.*, **9**, 5315, **1989**.
65. JAKIMSKA A., KONIECZKA P., SKÓRA K., NAMIEŚNIK J. Bioaccumulation of metals in tissues of marine animals. Part II – metal concentrations in animal tissues, *Pol. J. Environ. Stud.*, **5**, 1127, **2011**.

