



МЕЖДУНАРОДНОЕ НАУЧНОЕ СОТРУДНИЧЕСТВО

UDC 669.018

KOCAŃDA Dorota

dorota.kocanda@wat.edu.pl

Military University of Technology, Warszawa, Poland

JURCZAK Wojciech

w.jurczak@amw.gdynia.pl

Polish Naval Academy, Gdynia, Poland

ŁUNARSKA Ellina

elunarska@ichf.edu.pl

Institute of Physical Chemistry of Polish Academy of Sciences, Warszawa, Poland

SZOCIŃSKI Michał

micszoci@chem.pg.gda.pl

Technical University of Gdansk, Gdansk, Poland

Received 05 July 2017.

CORROSION AND CAVITATION RESISTANCES OF LOW ALLOY STEEL AFTER FRICTIONAL-MECHANICAL TREATMENT

Paper presents the results of the studies of wear, corrosion and cavitation resistances of the S355J2 low alloy medium carbon steel subjected to surface modification by friction-mechanical treatment, as tested in sea water simulated solution. To evaluate the effect of the surface treatment, the comparative studies of the corrosive properties of the steel before and after treatment have been considered. The treatment due to a severe plastic deformation enable forming nanocrystalline structure of steel with grain sizes in the range 20–50 nm and the favorable internal stress state within the treated layer. The research indicated as well that the applied surface treatment improved the steel resistance to the wear and erosion-corrosion but decreased the resistance to general corrosion and stress corrosion. The surface treated steel revealed the lower diffusivity and the lower transport of hydrogen into the material core. Hydrogen collecting within the surface layer did not proceed to the deeper layer of structural metal, and thus prevented it from the hydrogen cracking.

Keywords: low alloyed medium carbon steel, friction-mechanical treatment, resistance to wear, corrosion, stress corrosion and cavitation, hydrogen diffusion coefficient

Introduction. In the active sea environment, the structural steels used in constructions of floating vessels and in hydrotechnical installations are subjected to the action of the complex physico-mechanical and electrochemical phenomena. There are: steel embrittlement induced by hydrogen, due to hydrogen absorption by the surface of the steel sheets or by the crack surfaces, cavitation erosion, stress corrosion cracking and corrosion fatigue. The above phenomena decrease the ability of the material to transmit the mechanical loading.

The usual rule at designing of the sea installations used to be the adjusting the structural material

properties to the service conditions, as salinity of the sea areas, water temperature, flora and fauna of the sea deposits on the immersed parts of the shell. Recently, the steels of the elevated or even of high strength steels (Cr-Ni-Mo steels, Cr-Mo steels) of high metallurgical purity, mostly having the low bainite (SE700) or bainite-martensite (OX812EM) microstructure have been applied, especially for the hulls of navy vessel and for the highly loaded constructions. However, the above steels are very expensive and could be only used for the special vessels or hydrotechnical installations. For that reason the steels of medium strength have been generally used as the hull materials.

In practice to protect the surface of the steel components of the sea installations from the action of sea environment special methods have been applied, such as cathodic protection, multilayer dye coatings with the corrosion inhibitors hampering the rate of initiation and propagation of crack corrosion and fatigue cracks and increasing the resistance of the steel to the biological corrosion. The very important are also the surface engineering methods [1–5] consisting of different surface treatment of steel sheets, as mechanical, chemical, thermal. The hybrid methods combining the different engineering techniques to form the multicomponent and composite coatings with increased service properties are also in a great importance.

To improve the service properties of the low alloyed medium carbon steels in the sea water simulating solution (3,5 % NaCl) the frictional-mechanical treatment has been considered and applied. In that treatment the friction energy of disc friction tool, rotating with a high speed against the treated element has been used. The very high local temperature and contact pressure within the micro area of the friction zone as well as a very high speed of cooling has led to formation of outer “white” layer, significant decrease in the grain size and the plastic deformation of the surface zone of the metal.

To study the service properties in the sea water environment, the S355J2 low alloyed medium carbon steel used for the vessel shells and having the good welding properties have been chosen. However, the examined steel characterizes by low resistance to the fatigue corrosion and the higher susceptibility to the corrosion, especially to stress corrosion cracking. The present study has been focused on the effects of the frictional-mechanical treatment producing the fine size grain microstructure and the favorable internal stress state within the treated layer, on the increase of resistance to wear, corrosion, cavitation erosion and on hydrogen absorption by the treated surface layer of steels. The fatigue properties of the examined steel, subjected to the friction-mechanical treatment have been presented elsewhere [6–7].

Materials and experimental procedures. Results.

Materials. The steel specimens were cut from the sheets of 12 mm thick of the ferritic-pearlitic S355J2 steel by means of the water jet method. The oxide layer has been removed from the specimen surface by the grinding papers and then with the magnet polishing devise. Chemical composition of the steel is performed in table 1. Mechanical properties of the steel in as received state have been given in table 2. The notations found in table 2 mean: σ_{YS} — yield stress, σ_{UTS} — ultimate tensile stress and RA — percentage reduction area.

The frictional-mechanical treatment is based on high speed friction leading to the temperature being in a friction node in order of 900–1200 °C, above the material phase transformation. Simultaneously, severe thermo-plastic deformation of a material component with a rapid cooling at a speed of 10^3 – 10^4 K/s due to heat transfer from surface layers into the coolant, tool

Table 1 — Chemical composition of the S355J2 steel

Steel	Chemical composition (wt. %)						
	C	Mn	Si	P	S	Cr	Ni
S355J2	0,19	1,40	0,196	0,013	0,006	0,02	0,01

Table 2 — Mechanical properties of the S355J2 steel

S355JR	Mechanical properties		
State	σ_{YS} , MPa	σ_{UTS} , MPa	RA 5 %
In delivery	360	533	18,5
Treated	362	537	34

and treated component takes place. Special lubricant medium PMS-100 as a carbon content diffusing substance was used as a coolant.

For the plane steel specimens the treatment has been done on both surfaces on the specially designed device using the rotated titanium alloy disc as working tool at the speed of 50 m/s. Longitudinal feed of the tool along the specimen axes was at the speed of 0,5 mm/rev. A depth of the tool penetration to the inside material characterizing a pressure force on the treated specimen was equal to 0,25 mm at the first run and at the linear speed 1 m/min. At second run of the tool the linear velocity was in order of 10 m/min and the table shift was equal to 0,5 mm/min. Simultaneously, a depth of tool penetration in the material was equal to 0,1 mm.

Thanks to the factors, namely, structural-phase transformation, carbon saturation of the specimen surface layer and its nanocrystalline structure lead to better strengthening of a component surface and refined microstructure. As the result, the outer white amorphous layer, 30–40 μm thick, of martensite-austenitic structure and of high microhardness (300–400 $\text{HV}_{0,1}$) has been observed in the specimen cross-section (figure 1 a). The deeper layers up to 200–250 μm thick with grain size reduction up to 20–50 nm of sizes have been formed (figures 1 b, c).

After the surface strengthening, the mechanical properties of the examined steel as measured in air have been insignificantly improved. However, the plasticity of the steel has decreased by 4 %.

Tests on internal stresses presented in the surface layer of the S355J2 steel after surface treatment were conducted with the use of the Roentgen method. Internal stresses were determined in the layers to the depth of 0,1 mm by means of the layer etching method. Research results proved that on surface *A* of the specimen there operated longitudinal compressive stresses $\sigma_{xx} = -303$ MPa and transverse tensile stresses $\sigma_{yy} = +298$ MPa (in relation to the working tool movement). On surface *B* of the specimen, there were measured longitudinal compressive stresses $\sigma_{xx} = -115$ MPa and transverse tensile stresses $\sigma_{yy} = +330$ MPa. At the depth of 0,1 mm, only compressive internal longitudinal stresses in the range of values $\sigma_{xx} = (-130, -180$ MPa) were measured on both sides of the speci-

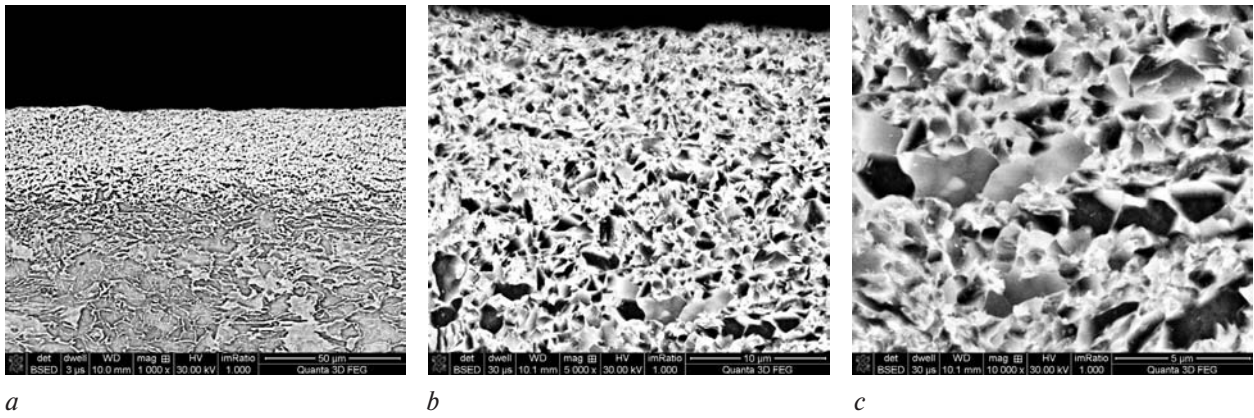

Figure 1 — SEM images of plastically deformed surface layer in the S355J2 steel after surface treatment seen:

a — on a longitudinal micro-section; *b* — on a transverse micro-section, mag. 5 000x; *c* — on a transverse micro-section, mag. 10 000x

men. Simultaneously, the transverse tensile stresses of value $\sigma_{yy} = +186$ MPa operated on surface *A* and the compressive stresses of value $\sigma_{yy} = -140$ MPa was determine on surface *B*.

To emphasize the effect of the corrosion environment on the steel specimens in as received and in treated states they have been immersed in test solution (3,5 % NaCl) for one year. After that the specimens have been subjected to the comparative examinations of the wear and the corrosion resistivity.

Resistivity of steel to the wear. The studies of the materials wear at the sliding motion have been done according to ASTM G99 using the T-01M Tester on the Pin-on-Disc device at the pressure 10 N and the slide rate 5,5 mm/s. For the steel in as received condition, the measurements of abrasive wear and the estimation of the friction coefficient have been carried out for three specimens by measuring the area of wear and the mean volume of removed material. The wear coefficient k_p defined as :

$$k_p = \frac{V_p}{F \cdot s}, \quad (1)$$

where V_p — volume of removed material, mm³; F — loading, N; s — path length, m.

For the S355J2 steel specimens in as received conditions k_p has been estimated as 2,27 mm³/N·m. The mean value of the friction coefficient stated

after doing of friction path of 300 m length has been estimated as $k_f = 0,6$ for the examined steel.

After applying the friction-mechanical treatment the steel specimens displayed a very high resistance to wear.

Erosion-cavitation resistance of steels. The erosion-cavitation resistance experiments have been done by flux impact method on the special device, which allowed the simultaneous study of three specimens at the speed rate 3040 rev/min and the linear speed of specimen 79,5 m/s. One side of specimens 25×40×12 mm has been truncated by 5 mm. The images of the surface of the steel specimens in as received condition before and at different stages of the erosion-cavitation resistance test are shown in figure 2. Figure 3 compare the mean values of the mass loss versus the time for the S355J2 steel before and after the surface treatment. It is seen that the steel subjected to surface treatment exhibited higher resistance to erosion-cavitation in comparison to the as received condition.

Effect of stress corrosion on mechanical properties of steel. The study of the stress corrosion resistance has been done using the specimens of geometry shown in figure 4. The specimens have been subjected to the following conditions: 1) immersed in test solution (3,5 % NaCl) for 1500 hrs; 2) immersed with additional loading $\sigma = 0,8\sigma_{YS}$; 3) exposition in salt spraying chamber.

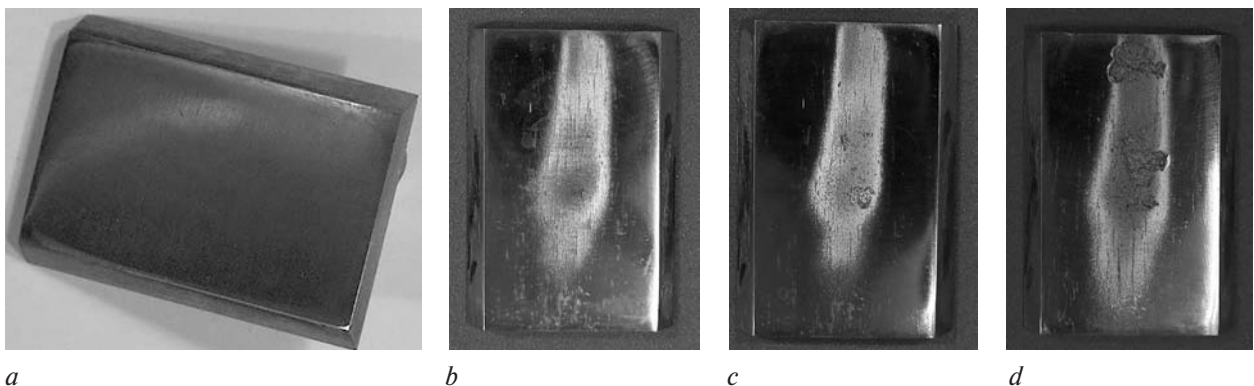

Figure 2 — Images of surface specimens in as received condition before erosion-cavitation test on S355 steel (*a*): *b* — after 165 min. of the resistance test; *c* — after 225 min. of the test; *d* — at the end of the test after 315 min.

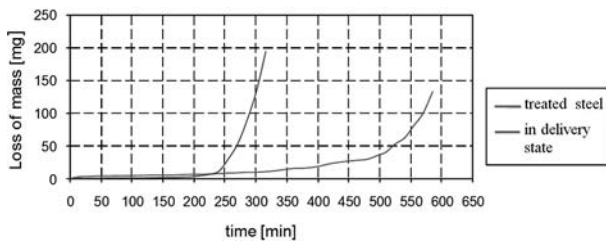

Figure 3 — The mean mass loss of S355J2 steel versus time in as received condition and after surface hardening

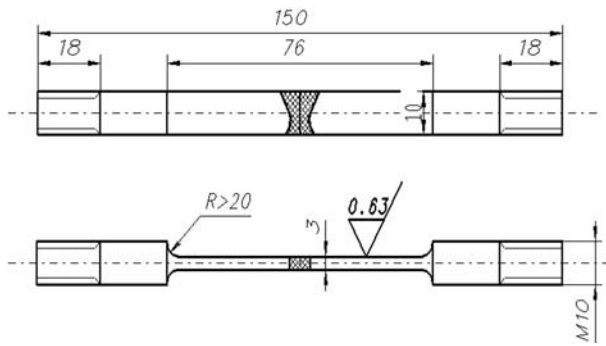

Figure 4 — Geometry of specimens: for the stress corrosion (mm); experiment

This one effect has been quantitatively estimated by the following coefficients:

$$K_{UTS} = \frac{\sigma_{UTS} - \sigma_{UTS_{wt}}}{\sigma_{UTS}} \cdot 100\%; \quad (2)$$

$$K_{A_5} = \frac{A_5 - A_{5t}}{A_5} \cdot 100\%, \quad (3)$$

where K_{UTS} — means percentage coefficient of mechanical properties variation of a material under the influence of sea water and tensile stress; σ_{UTS} — ultimate tensile stress of a material; $\sigma_{UTS_{wt}}$ — ultimate tensile stress of a material subjected to action of sea water and tensile loading; K_{A_5} — percentage coefficient of unit elongation variation of specimen made of a material under loading of $\sigma = 0,8\sigma_{YS}$; A_5 — unit elongation variation of specimen made of a material; A_{5t} — unit elongation variation of specimen made of a material under the influence of sea water and tensile load.

The comparative studies of the S355J2 steel behavior in as received and after surface treated conditions, after exposition to corrosive medium and additional loading as well as in environment of salt spray allowed to estimate the effect of surface treatment on the mechanical properties using the relation given above. The results are shown in figure 5. It is seen that steel subjected to the frictional-mechanical treatment exhibited higher resistance to the changes in mechanical properties after exposition in salt spray (KS) than untreated steels. Quite surprising appeared the results showing the more pronounced decrease in mechanical properties after immersion in the test solution (KO) and after immersion in the test solution while loaded (KN) for treated steels, than for as in received ones (figures 5 a, b). Those differences in resistance to the action of aggressive environment and stress have been seen in the case of the treated S355J2

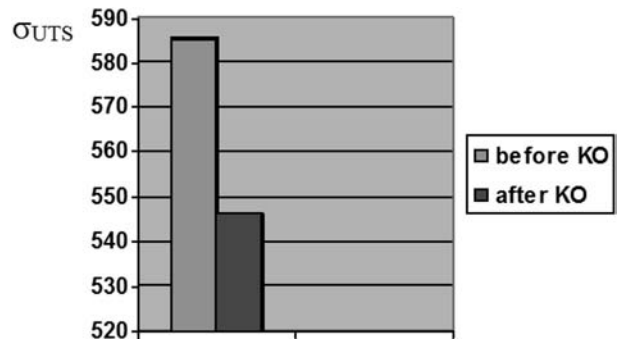

a

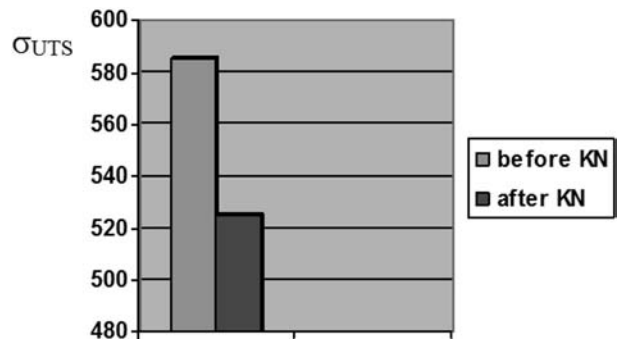

b

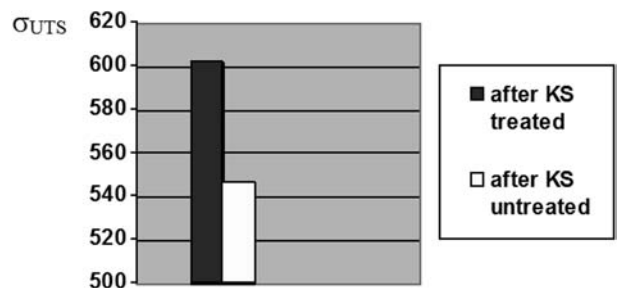

c

Figure 5 — The changes of the strength of as received and surface treated steel S355J2: a — after the exposition in test solution; b — in test solution with applied stress; c — after exposition in salt spray

steel. Such a behavior of the surface treated steel in the corrosion environment might be explained by the lower thermodynamic stability of the material within the treated zone associated with its severe plastic deformation.

As follows [5] dispersion of the material structure and plastic deformation activate electrochemical interaction between metal surface and corrosion environment. As this consequence, the surface hardened steel corroded more rapidly than the untreated one. It has been also seen at the high cycle fatigue experiments done in the 3,5 % NaCl solution. Despite of the use the zinc protector, the surface of treated specimens has been quickly covered by the corrosion deposits.

The results of those experiments led to the conclusions that the surface hardening increased the resistance to wear and cavitation erosion of steels. It does not significantly accelerate the corrosion. However, the corrosion of hardened elements pro-

pagated quite rapidly where their surface become damaged or subjected to stresses. In those cases the additional protection should be applied to the hardened surface, such as the coatings with a dye containing the corrosion inhibitors.

A further series of corrosion resistance studies have been carried out with the steel specimens earlier subjected to the surface friction-mechanical treatment and for other specimens without surface modification. Then the surfaces of both groups of the specimens were protected by applying an anti-corrosion coating which consisted of three layers. The type of anti-corrosion coating used was intended to protect marine constructions, including immersion. All paints were applied by airless spray and the thickness of the coating set was about 240 μm . Then the samples were exposed for one year in sea water simulated solution. After this period, the samples were subjected additionally to the HCF or LCF fatigue tests. After those tests the condition of the coatings as well as their adhesion to the steel surfaces were checked. The figures 6 and 7 show the pictures of the painted specimens. There is seen a satisfactory state of paint coatings on the samples with modified surfaces by friction-mechanical treatment (figure 6). In the case of samples with untreated surfaces (figure 7) after a yearly exposure in a corrosive environment and after partial fatigue tests, damage to the paint coating resulted from the gradual paint peeling from the steel surface was noted.

These studies have confirmed the beneficial effect of frictional-mechanical treatment applied to the surface of steel samples to increase their resistance to corrosive environments. The treatment has increased the roughness of the surface and should therefore increase the adhesion of the protective coating to the steel surface. Surface roughness was measured after modification. The average value of surface roughness R_a was in the range of 0,6–0,9 mm.

Hydrogen ingress into the steels. The content of hydrogen and its transport into the surface treated specimen have been evaluated. The content of hydrogen absorbed from the test solution has been estimated by means of vacuum extraction method and the hydrogen permeation rate has been measured by electrochemical method. The hydrogen diffusion coefficient has been also calculated.

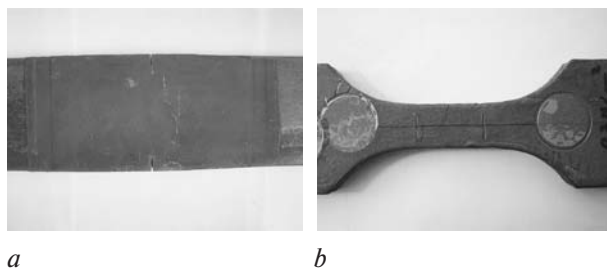

Figure 6 — The condition of the anti-corrosion coatings applied to the surface treated steel specimens after one year exposition in 3,5 % NaCl environment and after HCF test (on left) or after LCF test (on right) up to 75 % lifetimes

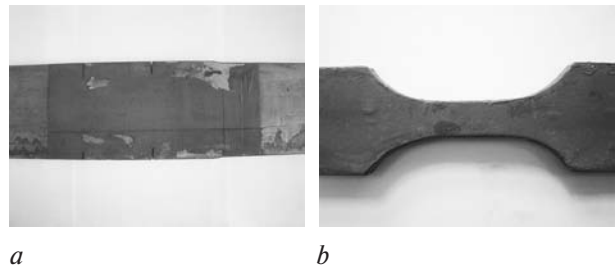

Figure 7 — The condition of the anti-corrosion coatings applied to the surface untreated steel specimens after one year exposition in 3,5 % NaCl environment and after HCF test (on left) or after LCF test (on right) up to 75 % lifetimes

In the treated steel the lattice hydrogen diffusion coefficient was equal to $2,7 \cdot 10^{-6} \text{ cm}^2/\text{s}$ and it was lower than in the material in as received state.

It has been shown that the surface treated steel revealed the lower diffusivity and the lower transport of hydrogen into the material core. It means that the surface treatment produced the traps for absorbed hydrogen. As those traps may serve the defects in the steel microstructure produced by the high plastic deformation and grain refining in the course of friction-mechanical treatment. The effects being also supported by the longer time of hydrogen desorption from the material.

Conclusions. The paper presents some the results of the comparative studies of the service properties of the S355J2 low alloyed medium carbon steel in as received conditions and after the friction-mechanical surface treatment in corrosive environment. From the experiments, it follows that the surface treatment caused the decrease in the strength of the steel after immersion in corrosive environment and after immersion with applied stresses. The steel revealed the increased resistance to corrosion in the salt spray. The surface treatment improved the resistance to the wear and erosion-corrosion. For the examined steel the increased hydrogen absorption has been observed because of the formation of the hydrogen traps due to the plastic deformation during the frictional-mechanical treatment and thus, due to multiplication of hydrogen trapps. However, hydrogen collecting within the surface layer did not proceed to the deeper layer of structural metal, and thus prevented it from the hydrogen cracking.

References

1. Kusiński J. Lasers and their applications in material science, Scientific Ed. Akapit, Kraków, 2000 (in Polish).
2. Wierchoń T., Ulbin-Pokorska I., Sikorski K. Corrosion resistance of chromium nitride and oxynitride layers produced under glow discharge conditions. *J. Surface and Coatings Technology*, 2000, no. 130, pp. 274–279.
3. Łunarska E., Nikiforow K., Wierchoń T., Ulbin-Pokorska I. Effect of plasma nitriding on hydrogen behavior in electroplated chromium coating. *J. Surface and Coating Technology*, 2001, no. 145, pp. 139–145.
4. Kocańda D., Górka A. *Formation of a metal coating by means of friction stir processing*, ICAF, 2011, Canada, pp. 167–178.
5. H. Nikiforchin, V. Kyrlyiv, O. Maksimiv, Z. Slobodian, O. Tsyrlunyk, Formation of surface corrosion-resistant nano-

- crystalline structure on steel. *Nanoscale Res Lett*, 2016, no. 11, pp. 1–6.
6. Kocańda D., Hutsaylyuk V., Ślęzak T., Torzewski J. Fatigue crack growth rates of S235 and S355 steels after friction stir processing. *Trans Tech Publications*, 2012, pp. 203–210.
 7. Kocańda D., Górka A., Grzelak K., Torzewski J., Lunarska E., Nikiforchin H., Kyryliv V. Fatigue characteristic of S355J2 steel after surface frictional-mechanical treatment in corrosive environment. *Solid State Phenomena*, 2015, pp. 21–26.

Дорота КОЦАНДА

E-mail: dorota.kocanda@wat.edu.pl

Военный технологический университет, г. Варшава, Польша

Войцех ДЖУРЧАК

E-mail: w.jurczak@amw.gdynia.pl

Польская военно-морская академия, г. Гдыня, Польша

Элина ЛУНАРСКА

E-mail: elunarska@ichf.edu.pl

Институт физической химии Польской академии наук, г. Варшава, Польша

Михал ЖОЦИНСКИ

E-mail: micszoci@chem.pg.gda.pl

Технический университет Гданьска, г. Гданьск, Польша

Поступила в редакцию 05.07.2017.

СОПРОТИВЛЕНИЕ КОРРОЗИИ И КАВИТАЦИИ НИЗКОЛЕГИРОВАННОЙ СТАЛИ ПОСЛЕ ФРИКЦИОННО-МЕХАНИЧЕСКОЙ ОБРАБОТКИ

В статье представлены результаты исследований сопротивления износу, коррозии и кавитации в моделируемом растворе морской воды низколегированной среднеуглеродистой стали S355J2, подвергнутой модификации поверхности фрикционно-механической обработкой. Для оценки влияния поверхностной обработки были проведены сравнительные исследования коррозионных свойств стали до и после обработки. Обработка путем большой пластической деформации позволяет формировать нанокристаллическую структуру стали с размерами зерен в диапазоне 20–50 нм и благоприятное внутреннее напряженное состояние внутри обработанного слоя. Исследование также показало, что обработка поверхности улучшила устойчивость стали к износу и эрозивной коррозии, но уменьшила устойчивость к общей коррозии и коррозии под напряжением. Сталь с обработанной поверхностью показала более низкую склонность к диффузии и более медленную транспортировку водорода в основной металл. Водород, диффундирующий в поверхностном слое, не переходил в глубь основного металла, и таким образом предотвращается его водородное растрескивание.

Ключевые слова: низколегированная среднеуглеродистая сталь, фрикционно-механическая обработка, устойчивость к износу, коррозия, коррозия под напряжением, кавитация

Список литературы

1. Кузински, Дж. Лазеры и их применение в материаловедении / Дж. Кузински. — Краков, 2000 (на польском языке).
2. Виержон, Т. Коррозионная стойкость нитрида хрома и слоев оксинитридных, производимых в условиях тлеющего разряда / Т. Виержон, И. Ульбинский-Покорска, К. Сикорски // Технологии поверхностей и нанесение покрытий. — 2000. — № 130. — С. 274–279.
3. Влияние плазменного азотирования на поведении водорода в гальваническом покрытии хрома / Е. Лунарска [и др.] // Технологии поверхностей и нанесение покрытий. — 2001. — № 145. — С. 139–145.
4. Коцанда, Д. Образование металлического покрытия с помощью обработки трением / Д. Коцанда, А. Горка // ICAF-2011. — Канада, 2011. — С. 167–178.
5. Формирование поверхностной коррозионно-стойкой нанокристаллической структуры на стали / Н. Найкфорчин [и др.] // Наномасштабные исследовательские письма. — 2016. — Т. 11. — С. 1–6.
6. Скорость роста усталостных трещин сталей S235 и S355 после обработки трением / Д. Коцанда [и др.] // Форум по материаловедению. — 2012. — Т. 726. — С. 203–210.
7. Усталостная характеристика стали S355J2 после поверхностной фрикционно-механической обработки в коррозионной среде, твердотельное явление / Д. Коцанда [и др.] // Твердотельные явления. — 2014. — Т. 224. — С. 21–26.