

Article

Detection and Removal of Priority Substances and Emerging Pollutants from Stormwater: Case Study of the Kołobrzaska Collector, Gdańsk, Poland

Paweł Jakubowicz ^{1,*}, Karolina Fitobór ^{1,*}, Magdalena Gajewska ¹ and Małgorzata Drewnowska ²

¹ Department of Environmental Engineering Technology, Faculty of Civil and Environmental Engineering, Gdansk University of Technology, 80-233 Gdansk, Poland; mgaj@pg.edu.pl

² Gdansk Water Ltd., 80-601 Gdansk, Poland; m.drewnowska@gdanskiewody.pl

* Correspondence: biuro@cobance.pl (P.J.); karolina.fitobor@pg.edu.pl (K.F.); Tel.: +48-58-347-1353 (K.F.)

† External Ph.D. student.

Abstract: Progressive urban development affects environmental balance and disrupts the hydrologic cycle, in which rainfall plays a significant role. Since rainwater is considered a valuable resource of the environment, many technical solutions are implemented that enable effective rainwater management. On the other hand, stormwater runoff from urban areas contains numerous (also toxic) substances, and therefore should be properly treated. In this study, a multistage constructed wetland (MCW) pilot installation was used to remove selected groups of priority substances and emerging pollutants from rainwater discharged from the urbanized catchment of the Kołobrzaska stormwater collector in Gdańsk, Poland. The obtained results show that rainwater runoff was characterized by a variable concentrations of heavy metals (Zn, Cd, Cu, Ni, Pb, Hg), polycyclic aromatic hydrocarbons (benzo(a)pyrene, benzo(b)fluoranthene, phenanthrene, fluoranthene and pyrene) and microplastics. Depending on the hydraulic load of the bed, the reduction efficiency for heavy metals ranged from 26.19 to 100%, and for microplastics from 77.16 to 100%, whereas for polycyclic aromatic hydrocarbons it was consistently high, and equaled 100%.

Keywords: rainwater management; quality of runoff; multistage constructed wetland system (MCWs); Mass Removal Rate; priority substances removal; microplastics



Citation: Jakubowicz, P.; Fitobór, K.; Gajewska, M.; Drewnowska, M. Detection and Removal of Priority Substances and Emerging Pollutants from Stormwater: Case Study of the Kołobrzaska Collector, Gdańsk, Poland. *Sustainability* **2022**, *14*, 1105. <https://doi.org/10.3390/su14031105>

Academic Editor: Miklas Scholz

Received: 21 December 2021

Accepted: 13 January 2022

Published: 19 January 2022

Publisher's Note: MDPI stays neutral with regard to jurisdictional claims in published maps and institutional affiliations.



Copyright: © 2022 by the authors. Licensee MDPI, Basel, Switzerland. This article is an open access article distributed under the terms and conditions of the Creative Commons Attribution (CC BY) license (<https://creativecommons.org/licenses/by/4.0/>).

1. Introduction

According to Polish law and the Water Law act, natural waters are an integral part of the environment and are a habitat for numerous organisms [1]. Therefore, they must be adequately protected, no matter whose property they are. Moreover, the Water Framework Directive recommends the introduction and regular monitoring of technical solutions aimed at the gradual reduction of priority substances and priority hazardous substances emissions [2]. These substances are listed in Annex X of the Water Framework Directive and include, e.g., polycyclic aromatic hydrocarbons, heavy metals (i.e., Zn, Cd, Cu, Ni, Pb, Hg) and their compounds. In addition, the literature on the subject also mentions pesticides/biocides, polybrominated diphenyl ethers (PBDE), bisphenol A (BPA), flame retardants, polychlorinated biphenyls (PCBs), alkylphenols, phthalates and chlorophenols [3–6].

In Poland, the main sources of water supply to the municipal sector are surface waters (used especially in industry and agriculture), which include flowing waters (rivers, streams, canals) and standing waters (natural and artificial reservoirs) [7]. Groundwater resources are used to a lesser extent—mostly as a source of water intended for human consumption. Statistic Poland reported that the total water consumption in 2020 was 8.4 km³, with the greatest share (71%, i.e., 6.3 km³) for industry and production purposes [8]. The supply and natural renewal of surface and groundwater are largely dependent on climatic and hydrological processes [9], and therefore on the sum of atmospheric precipitation. Along with

the progressive development of urban areas (cities and large agglomerations), the natural hydrologic cycle is gradually disrupted. It is caused, among other things, by deforestation for investment purposes [10,11], the sealing of a catchment area [12–14] and the regulation of rivers and watercourses. As a consequence, it leads to excessively dynamic outflow, local inundations and floods. The degree of surface sealing influences the amount of rainwater runoff, while the method of spatial development of the area affects the quality of runoff [15]. Thus, it can be assumed that the type of catchment area affects the structure of water balance [16]. Rainwater can become polluted as it passes through the atmosphere [17–19]. Falling raindrops catch solid particles from the atmospheric air, as well as liquid or gaseous substances, which to some extent shape the quality of precipitation. In particular, dust, smoke or chemical substances from industrial or agricultural areas may deteriorate rainwater quality [20,21], which may also result in the appearance of new pollutants in the aquatic environment (i.e., the so-called *emerging pollutants* (EPs)) that have not been monitored before and for which there are no regulatory standards, such as pharmaceuticals and personal hygiene products, veterinary products, endocrine disruptors and microplastics [22–25]. Depending on the duration, intensity and time interval between rainfall and the presence of other natural and anthropogenic factors, rainwater quality is highly variable. However, it is said that progressive urbanization has the greatest negative impact. On the other hand, urbanization does not always have to be associated with a reduction in rainwater infiltration and hence the impoverishment of groundwater resources [26]. On the contrary, it can create conditions that contribute to the formation of new sources or enhance the functioning of the existing ones, especially when new technical and engineering solutions are implemented for rational water management. Nevertheless, such dynamic changes, caused mainly by anthropopression, make it necessary to regularly control the quality of the aquatic environment. Moreover, the newly introduced HELCOM Recommendation 23/5 has imposed an approach based on ecosystem services to stormwater management planning. This means that stormwater should be regarded as a valuable resource that improves the state of the environment and the well-being of citizens, maintains biodiversity, and promotes a good condition in surface and groundwater. In all cases, treatment and utilization at source should have a higher priority in stormwater management, and for high-risk stormwater, a water-sensitive urban design should be applied [27].

The aim of the study was to detect and remove priority substances, as well as emerging pollutants, from stormwater using multistage constructed wetland systems (MCWs), discharged from the urbanized catchment area of the Kołobrzaska stormwater collector in Gdańsk, Poland. MCW is part of the Nature-Based Solutions (NBS) and thus, according to the International Union for Conservation of Nature (IUCN), is defined as “action to protect, sustainably manage and restore natural or modified ecosystems, that addresses societal challenges effectively and adaptively, simultaneously providing human well-being and biodiversity benefits”.

2. Materials and Methods

Stormwater from grey infrastructure (i.e., stormwater collector) was directed to the pilot station using a piston pump, as presented in Figure 1. The test samples were taken directly from the retention tank of Kołobrzaska collector, and after the treatment processed in a multistage wetland system (treated sewage). Heavy metals such as zinc, cadmium, copper, nickel and lead were determined by inductively coupled plasma optical emission spectrometry (ICP-OES), while mercury was determined by atomic absorption spectrometry (AAS). The HPLC-FLD/UV method, i.e., high-performance liquid chromatography with fluorescence/spectrophotometric detection, was used to determine polycyclic aromatic hydrocarbons. Samples for the presence of microplastics were collected using the UFO (Universal Filtering Object) device, provided as part of the FanPLESStic-sea project, co-funded by the European Union (European Regional Development Fund) under the Interreg Baltic Sea Region Programme 2014–2020. The following methods were used to determine microplastics:

- (1) in the particle range of 10–500 μm —the micro-Fourier transform infrared spectroscopy method (FPA- $\mu\text{FT-IR}$);
- (2) for particles larger than 500 μm —total weakened infrared spectroscopy (ATR-FTIR).

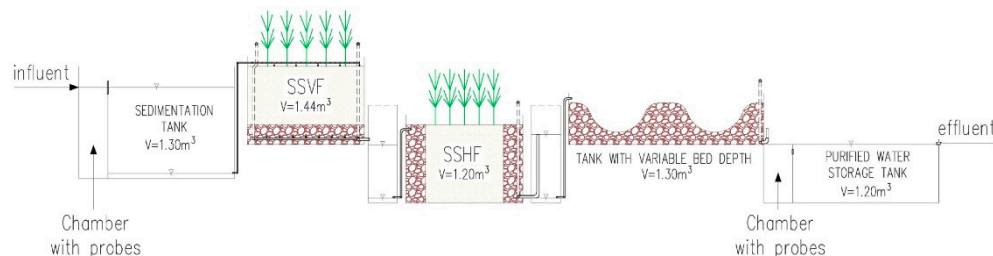

Figure 1. Technological scheme of the MCWs. 1. Sedimentation tank, 2. 1st stage bed with subsurface vertical flow (SSVF), 3. 2nd stage bed with subsurface horizontal flow (SSHF), 4. reservoir with variable bed depth, 5. purified water storage tank; S1 and S2—water-collecting wells after SSVF and SSHF beds (source: own study).

In order to assess the effectiveness of the removal of selected pollutants, Mass Removal Rate (MRR) was used based on the removed loads of pollutants [28,29]:

$$\text{MRR} = \frac{(C_{\text{in}} \cdot Q_{\text{in}}) - (C_{\text{out}} \cdot Q_{\text{out}})}{A}, \quad [\text{g} \cdot \text{m}^{-2} \cdot \text{d}^{-1}] \quad (1)$$

where:

C_{in} —pollutant concentrations in the inflow [$\text{g} \cdot \text{m}^{-3}$];

Q_{in} —inflow to the bed [$\text{m}^{-3} \cdot \text{d}$];

C_{out} —pollutant concentrations in the outflow [$\text{g} \cdot \text{m}^{-3}$];

Q_{out} —outflow from the bed [$\text{m}^{-3} \cdot \text{d}$];

A —total area of beds [m^2].

The removal efficiency (%) of heavy metals, polycyclic aromatic hydrocarbons and microplastics concentrations from stormwater was calculated using the formula:

$$\eta = \frac{L_i - L_e}{L_i} \cdot 100\%, \quad [\%] \quad (2)$$

where:

L_i —pollutants mass loading inflow,

$$L_i = \frac{C_{\text{in}} \cdot Q_{\text{in}}}{A}, \quad [\text{g} \cdot \text{m}^{-2} \cdot \text{d}^{-1}] \quad (3)$$

L_e —pollutants mass loading outflow,

$$L_e = \frac{C_{\text{out}} \cdot Q_{\text{out}}}{A}, \quad [\text{g} \cdot \text{m}^{-2} \cdot \text{d}^{-1}] \quad (4)$$

Hydraulic Loading Rate (HLR) was calculated using the formula [30]:

$$\text{HLR} = \frac{Q}{A}, \quad [\text{m}^3 \cdot \text{m}^{-2} \cdot \text{d}^{-1}]; \quad [\text{mm} \cdot \text{d}^{-1}] \quad (5)$$

where:

$Q = Q_{\text{in}}$ —inflow from the bed [$\text{m}^{-3} \cdot \text{d}$];

A —total area of beds [m^2].

The MCW pilot installation was designed to conduct research on the effectiveness of removing specific and newly appearing pollutants in the environment, including microplastics, from stormwater. The pilot facility is located in Gdańsk (Poland), in the seaside district

of Brzeźno, at the mouth of the Kołobrzaska collector in the Bay of Gdańsk (geographic coordinates: 54°24′31.0″ N, 18°36′59.9″ E). The installation consists of the following parts:

- (1) Five steel tanks (including a multistage wetland system) comprising elements of the filtration system through which the rainwater supplied to the system flows successively;
- (2) Two multi-parameter stations for continuous water quality measurement located respectively at the end and the beginning of the system (chamber with probes);
- (3) One mobile (measuring basic water parameters in each of the tanks), compact, multi-parameter, battery-powered water quality measurement station;
- (4) Hydraulic system of the installation ensuring the intake of water from the collector and the flow of water between the tanks, together with the control system.

Tanks 2 to 4 (beds) were filled with gravel with a grain size of 2–8 mm and 16–32 mm. The beds SSVF and SSHF were planted with common reed (*Phragmites australis*), which is one of the most basic and effective macrophytes, used for the treatment of various types of wastewater [31–33]. It should also be added that the total area of the beds was $A = 4.64 \text{ m}^2$.

The Kołobrzaska stormwater collector is a type of rainwater drainage system (hence its official name—collector) and was created as a result of the gradual modification of the natural watercourse Kołobrzaska's stream (historical name). The anthropopression process led to the transformation of the natural regulator of the water relations into a transmission channel. It transports rainwater and snowmelt from the areas of the following districts of the city of Gdańsk: Oliwa, Wrzeszcz, Zaspka, Przymorze and Brzeźno (Figure 2) [34]. The total length of the collector is approximately 3865 m, with a variable cross-section. The final water receiver of the stormwater collector is the Bay of Gdańsk. At the end of the collector, a settling tank with dimensions of $114 \times 14 \text{ m}$ and depth of about 1.4 m is located, which pretreats rainwater (by sedimentation and aeration). The total area of the Kołobrzaska stormwater collector catchment area is approximately 1735.2 ha (i.e., 17.35 km²) and it can be divided into two main areas (upper and lower catchment), varying in terms of morphological structure and land use. The upper catchment consists of moraine hills with a significant degree of afforestation and large land slopes and areas with compact and loose settlement, where slopes are smaller. The boundary of the upper catchment area is the railway embankment of the Gdańsk–Gdynia route, at the intersection of Brzeźno–Kołobrzaska stormwater collectors and the crossroad of Grunwaldzka Street and Kołobrzaska Street. The lower catchment is an area of intensive development (urbanized, heavily modified areas) with a slightly sloping terrain. Its borders are the railway embankment of the Gdańsk–Gdynia route, and on the other side the coastal belt area coinciding with the shoreline of the Bay of Gdańsk. As defined in the Water Law act, a heavily modified surface water body is one the nature of which has been significantly changed as a result of physical transformations related to human activities. In accordance with Directive 2000/60/EC, changes in the hydro-morphological characteristics of surface water bodies are mainly caused by the use of water in the following areas of activity: shipping, drinking water storage and supply, energy production, irrigation, regulation, flood protection and the drainage of land. Although the Water Framework Directive does not indicate urbanization as one of the factors that may have an impact on hydromorphological changes, it should be assumed that pressure caused by urbanization processes has a significant impact on the morphological conditions of water, such as the shape of the river bed, the variability of width and depth, flow velocity, and the structure of the coastal zone. Due to the fact that urbanization is a permanent and irreversible process, it should be taken into account in the procedure of water status classification. As mentioned, the Kołobrzaska stormwater collector is the result of the progressive development of the natural watercourse. Therefore, it is included in the category of heavily modified surface water bodies [35].

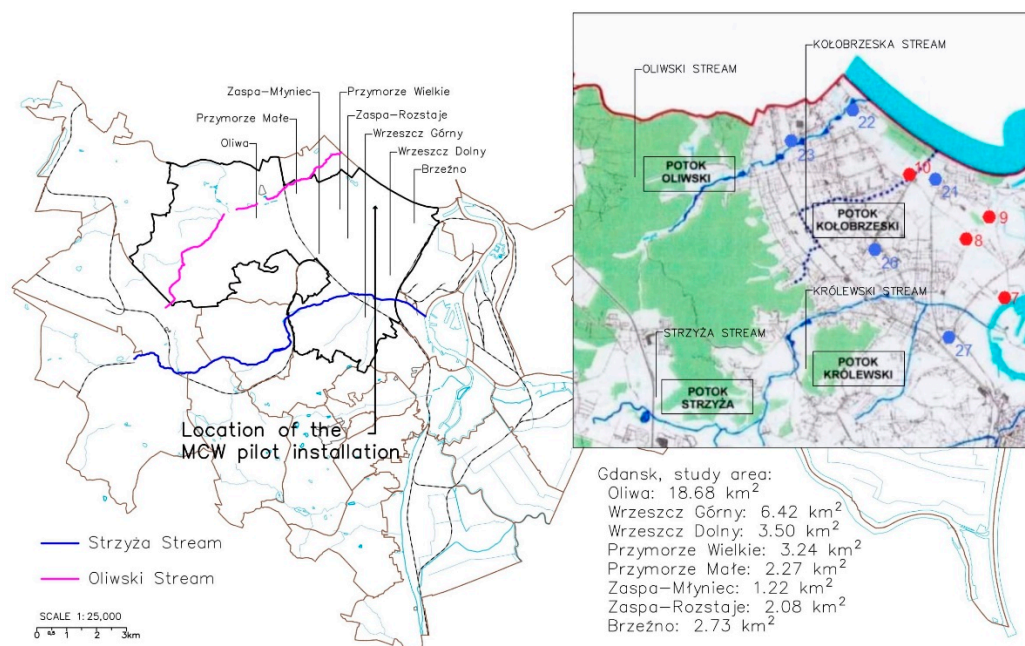

Figure 2. The studied catchment area of the Kołobrzeska collector, Gdańsk (Poland). Districts: 1. Oliwa, 18.68 km²; 2. Wrzeszcz Górny, 6.42 km²; 3. Wrzeszcz Dolny, 3.50 km²; 4. Brzeźno, 2.73 km²; 5. Przymorze Wielkie, 3.24 km²; 6. Przymorze Małe, 2.27 km²; 7. Zaspa-Rozstaje, 2.08 km²; 8. Zaspa-Młyniec, 1.22 km² (source: own study based on [34]).

3. Results and Discussion

The results of continuous water flow measurements in the three series of investigations are presented in Table 1.

Table 1. Average daily flows in individual test series, expressed in L day⁻¹.

	Series 1		Series 2		Series 3	
	07/10/2020–27/10/2020		07/05/2021–27/05/2021		06/08/2021–26/08/2021	
	Influent	Effluent	Influent	Effluent	Influent	Effluent
Day 1	124.46	127.11	377.01	225.58	688.66	660.12
Day 2	282.50	296.60	363.90	234.20	693.26	645.19
Day 3	297.01	264.82	355.31	222.36	682.78	646.94
Day 4	295.95	276.67	387.83	217.00	657.58	606.10
Day 5	288.65	252.59	407.04	199.32	664.13	639.43
Day 6	280.89	249.95	406.34	208.95	674.14	637.34
Day 7	285.58	250.56	391.96	210.29	665.64	598.15
Day 8	293.72	300.61	364.60	214.35	663.17	613.56
Day 9	117.16	126.38	327.86	191.66	662.74	608.28
Day 10	248.37	203.22	321.46	229.69	640.58	572.90
Day 11	291.60	276.47	309.04	218.11	644.30	603.89
Day 12	290.77	276.21	290.32	214.41	623.93	580.61
Day 13	286.21	249.03	264.48	197.63	641.40	598.80
Day 14	237.06	206.53	280.32	220.36	647.78	618.22

Table 1. Cont.

	Series 1		Series 2		Series 3	
	07/10/2020–27/10/2020		07/05/2021–27/05/2021		06/08/2021–26/08/2021	
	Influent	Effluent	Influent	Effluent	Influent	Effluent
Day 15	296.41	263.59	320.50	216.90	646.22	587.98
Day 16	289.03	265.80	341.15	192.49	648.55	598.56
Day 17	282.93	288.29	353.32	222.61	661.73	610.32
Day 18	295.67	263.68	363.29	215.98	666.34	607.90
Day 19	303.49	284.58	375.66	209.32	663.46	637.75
Day 20	294.22	261.00	367.41	203.66	567.55	502.06
Day 21	267.30	192.71	377.18	216.27	667.01	674.78
Mean value	268	246	350	212	656	612

Based on the registration of flow meters installed at the pilot station, the average daily flows were determined for the period of 21 days preceding the sampling for testing (for the individual series). In order to calculate the pollutant load index, the flows were averaged (and expressed as arithmetic mean), which is shown in Table 1, as follows:

- series 1— $Q_{in} = 268 \text{ L}\cdot\text{day}^{-1} = 0.268 \text{ m}^{-3}\cdot\text{d}^{-1}$; $Q_{out} = 246 \text{ dm}^{-3}\cdot\text{d}^{-1} = 0.246 \text{ m}^{-3}\cdot\text{d}^{-1}$;
- series 2— $Q_{in} = 350 \text{ L}\cdot\text{day}^{-1} = 0.350 \text{ m}^{-3}\cdot\text{d}^{-1}$, $Q_{out} = 212 \text{ dm}^{-3}\cdot\text{d}^{-1} = 0.212 \text{ m}^{-3}\cdot\text{d}^{-1}$;
- series 3— $Q_{in} = 656 \text{ L}\cdot\text{day}^{-1} = 0.656 \text{ m}^{-3}\cdot\text{d}^{-1}$, $Q_{out} = 612 \text{ dm}^{-3}\cdot\text{d}^{-1} = 0.612 \text{ m}^{-3}\cdot\text{d}^{-1}$.

The average daily flows were variable and ranged from 268 to 656 $\text{L}\cdot\text{day}^{-1}$ at the inflow to the pilot station, and from 212 to 612 $\text{L}\cdot\text{day}^{-1}$ at the outflow from the station. Therefore, hydraulic load (expressed as Hydraulic Loading Rate (HLR)) was also variable, and was in the range $57.76 \div 131.90 \text{ mm}\cdot\text{d}^{-1}$, that is:

- series 1— $\text{HLR} = 57.76 \text{ mm}\cdot\text{d}^{-1}$;
- series 2— $\text{HLR} = 75.43 \text{ mm}\cdot\text{d}^{-1}$;
- series 3— $\text{HLR} = 131.90 \text{ mm}\cdot\text{d}^{-1}$.

3.1. Heavy Metals

As shown in Table 2, in the waters of the Kołobrzaska collector, selected heavy metals were detected. The concentrations are given in $\text{mg}\cdot\text{m}^{-3}$. Significant values were recorded for zinc and copper.

First of all, attention should be paid to certain episodes related to the increase in Zn, Cu and Pb concentrations after the purification processes. In series 1 of our studies, an increase in the concentration of Zn was observed, from 49 to 278 $\text{mg}\cdot\text{m}^{-3}$. Moreover, an increase in the concentration of Cu from a value below the limit of quantification (<19) to a value of 19 $\text{mg}\cdot\text{m}^{-3}$, and an increase in Pb concentration from a value below the limit of quantification (<6) to the value of 9 $\text{mg}\cdot\text{m}^{-3}$, were recorded. In series 3 of our studies, an increase in Zn concentration from 86 to 96 $\text{mg}\cdot\text{m}^{-3}$ was observed. It should also be emphasized that in the case of Cu and Pb, these elements were detected in purified water, although they were not found at the inflow to the pilot station. The changes in the concentrations of these elements are probably caused by the suffosion phenomenon, i.e., the washing out of these elements from the beds or their migration from the atmospheric air along with rainfall. The unequivocal identification of factors that may have an influence on the increase in Zn concentration, and the appearance of Cu and Pb in the treated water, requires further research, taking into account a greater number of repeatable results. Additional aspects also need to be considered, such as flow rate, the occurrence of precipitation (especially torrential precipitation events), as well as the monitoring background, e.g., concentrations of heavy metals in the atmospheric air.

Table 2. Heavy metals' concentration values measured in individual test series (expressed in $\text{mg}\cdot\text{m}^{-3}$) and the maximum permissible values specified in Polish regulations.

Determined Chemical Element		Heavy Metals Concentration						Maximum Permissible Value (*)
		Date of Sampling: 28/10/2020		Date of Sampling: 28/05/2021		Date of Sampling: 27/08/2021		
		Influent	Effluent	Influent	Effluent	Influent	Effluent	
		Series 1		Series 2		Series 3		
Zn	$\text{mg}\cdot\text{m}^{-3}$	49	278	262	52	86	96	no data
Cd	$\text{mg}\cdot\text{m}^{-3}$	<0.6 (**)	<0.6	<0.6	<0.6	<0.6	<0.6	0.45 ÷ 1.50 (***)
Cu	$\text{mg}\cdot\text{m}^{-3}$	<19	19	83	44	42	31	no data
Ni	$\text{mg}\cdot\text{m}^{-3}$	8	3	6	4	3	3	34
Pb	$\text{mg}\cdot\text{m}^{-3}$	<6	9	18	<6	<6	<6	14
Hg	$\text{mg}\cdot\text{m}^{-3}$	0.4	0.01	<0.01	<0.01	0.15	0.07	0.07

(*) Maximum permissible value according to Polish regulations [35]. (**) Concentration below the quantification limit. (***) Value depends on the class of water hardness.

The concentration of zinc ranged from 49 to 278 $\text{mg}\cdot\text{m}^{-3}$, whereas the concentration of copper from 19 to 83 $\text{mg}\cdot\text{m}^{-3}$. National regulations do not provide maximum permissible values for these elements. This may be due to the fact that Zn and Cu do not pose a significant threat to human health if they are present in trace amounts. In addition, they are also necessary for the proper functioning of living organisms [36–38]. However, other authors report that there are certain threshold levels of zinc, the exceeding of which may negatively affect the aquatic organisms and human population; they are, respectively, 27 $\mu\text{g}\cdot\text{L}^{-1}$ or 30 $\mu\text{g}\cdot\text{L}^{-1}$ (for aquatic organisms) and 107 $\mu\text{g}\cdot\text{L}^{-1}$ (for humans) [39–41]. In the conducted research, a significant reduction in zinc from 262 $\text{mg}\cdot\text{m}^{-3}$ to 52 $\text{mg}\cdot\text{m}^{-3}$ was recorded in the second period of the pilot installation operation (series 2), while in period 1 (series 1) and period 3 (series 3), there was an increase in concentration, which requires further observation. In terms of the processes taking place in the bed with subsurface horizontal flow (SSHF), in all three series, an increase in the value of zinc concentration was observed after rainwater had passed through this bed (as presented in Figure 3).

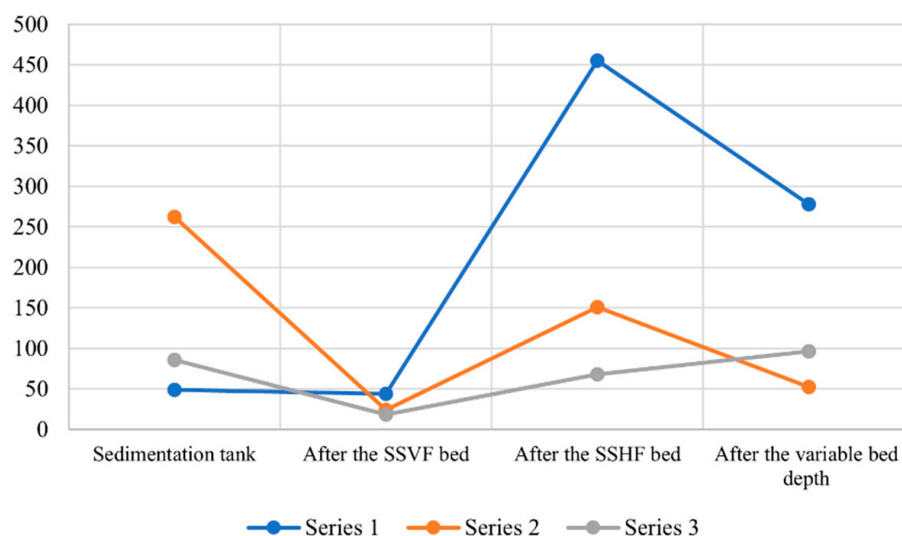
**Figure 3.** Changes in the zinc concentration values after subsequent stages of rainwater treatment in the MCW system.

It should also be noted that zinc migration may be caused by the leaching of this element from the galvanized steel components used in the construction of the pilot station. As other researchers have observed [42,43], a common source of zinc in rainwater is all types of engine oils, hydraulic fluids, galvanized chain-link fences, galvanized HVAC or other ductwork on facility roofs, or even roofing materials (galvanized sheet). In addition, cadmium was not detected in any of the tested samples. However, the occurrence of nickel, lead and mercury was observed. The nickel concentration ranged from $3 \text{ mg}\cdot\text{m}^{-3}$ to $8 \text{ mg}\cdot\text{m}^{-3}$ and did not exceed the maximum permissible value of $34 \text{ mg}\cdot\text{m}^{-3}$. Fluctuations in lead concentration were also observed, from $9 \text{ mg}\cdot\text{m}^{-3}$ to $18 \text{ mg}\cdot\text{m}^{-3}$, and in series 2 it exceeded the maximum permissible value of $14 \text{ mg}\cdot\text{m}^{-3}$. The mercury concentrations at the inflow to the pilot station were respectively $0.4 \text{ mg}\cdot\text{m}^{-3}$ (series 1) and $0.15 \text{ mg}\cdot\text{m}^{-3}$ (series 3). In both cases, they exceeded the limit value defined in national regulations as $0.07 \text{ mg}\cdot\text{m}^{-3}$.

The effectiveness of heavy metal reduction in the MCW pilot installation was varied, as shown in Table 3. For series 1, where the hydraulic load was the lowest and amounted to $57.76 \text{ mm}\cdot\text{d}^{-1}$, a reduction in nickel and mercury concentrations was observed. In the case of nickel, the MRR was $0.30 \text{ mg}\cdot\text{m}^{-2}\cdot\text{d}^{-1}$, thus the reduction efficiency was 65.58%. The mercury concentration was reduced by 97.71%, whereas the MRR was $0.02 \text{ mg}\cdot\text{m}^{-2}\cdot\text{d}^{-1}$. As a result, in both cases, a reduction in the mercury concentration was achieved to a value below the maximum permissible value. In series 2, no increase in the concentrations of metals was observed after the purification processes. The hydraulic load was $75.43 \text{ mm}\cdot\text{d}^{-1}$, and at this value, the best results of the installation's operation were recorded. A reduction in zinc concentration at the level of 87.98% and the high MRR of $17.39 \text{ mg}\cdot\text{m}^{-2}\cdot\text{d}^{-1}$ were observed. The MRR for copper was $4.25 \text{ mg}\cdot\text{m}^{-2}\cdot\text{d}^{-1}$, which is equivalent to a reduction in this element at the level of 67.89%. In the case of nickel, MRR was $0.27 \text{ mg}\cdot\text{m}^{-2}\cdot\text{d}^{-1}$, whereas for lead the MRR was recorded at the level of $1.36 \text{ mg}\cdot\text{m}^{-2}\cdot\text{d}^{-1}$, which correspond to 59.62% and 100% reductions in the concentration, respectively. During the third period of operation of the installation (series 3), the hydraulic load was the highest, and amounted to $131.90 \text{ mm}\cdot\text{d}^{-1}$. In this period, a reduction in copper and mercury was observed. The MRR for copper was $1.85 \text{ mg}\cdot\text{m}^{-2}\cdot\text{d}^{-1}$, whereas for mercury it was $0.01 \text{ mg}\cdot\text{m}^{-2}\cdot\text{d}^{-1}$, showing reductions on the level of 26.19% and 56.46%, respectively.

Table 3. Summary of the research results illustrating the effectiveness of heavy metal reduction in individual test series, expressed as MRR and η index (depending on the HLR).

	Series 1 07/10/2020–27/10/2020			Series 2 07/05/2021–27/05/2021			Series 3 06/08/2021–26/08/2021		
	HLR $\text{mm}\cdot\text{d}^{-1}$	MRR $\text{mg}\cdot\text{m}^{-2}\cdot\text{d}^{-1}$	η (%)	HLR $\text{mm}\cdot\text{d}^{-1}$	MRR $\text{mg}\cdot\text{m}^{-2}\cdot\text{d}^{-1}$	η (%)	HLR $\text{mm}\cdot\text{d}^{-1}$	MRR $\text{mg}\cdot\text{m}^{-2}\cdot\text{d}^{-1}$	η (%)
Zn	57.76	−11.91 *	−420.77 *	75.43	17.39	87.98	131.90	−0.50 *	−4.14 *
Cd	57.76	0.00	0.00	75.43	0.00	0.00	131.90	0.00	0.00
Cu	57.76	−1.01 *	0.00	75.43	4.25	67.89	131.90	1.85	26.19
Ni	57.76	0.30	65.58	75.43	0.27	59.62	131.90	0.00	0.00
Pb	57.76	−0.48 *	0.00	75.43	1.36	100.00	131.90	0.00	0.00
Hg	57.76	0.02	97.71	75.43	0.00	0.00	131.90	0.01	56.46

(*) negative values indicate an increase in the concentration of a given element after the purification process.

3.2. Polycyclic Aromatic Hydrocarbons (PAHs)

Polycyclic aromatic hydrocarbons (PAHs) are present in significant concentrations in the atmospheric air, especially in the vicinity of busy roads and streets, as well as in industrial areas. These organic substances are formed during the incomplete combustion of fossil fuels in power stations and individual households, or in fuels for car engines [44,45]. As a result of wet and dry deposition, PAHs accumulate on the surface of the ground, which

favors their further migration to surface waters, groundwater, and bottom sediments [46]. Moreover, as proven by Al Ali et al., polycyclic aromatic hydrocarbons mostly migrate to waters from polluted surfaces (e.g., covered with road dust), while atmospheric deposition (as a source) only accounts for 10% of the total amount of PAHs in surface runoff [47]. Table 4 includes only selected polycyclic aromatic hydrocarbons that were detected in rainwaters of the Kołobrzaska collector, such as benzo(a)pyrene, benzo(b)fluoranthene, phenanthrene, fluoranthene and pyrene. The concentrations of the determined PAHs are expressed in $\mu\text{g}\cdot\text{m}^{-3}$.

Table 4. Polycyclic aromatic hydrocarbons' concentration values measured in individual test series (expressed in $\mu\text{g}\cdot\text{m}^{-3}$) and the maximum permissible values specified in Polish regulations.

		Date of Sampling: 28/10/2020		Date of Sampling: 28/05/2021		Date of Sampling: 27/08/2021		Maximum Permissible Value (*)
		Influent	Effluent	Influent	Effluent	Influent	Effluent	
		Series 1		Series 2		Series 3		
Benzo(a)pyrene	$\mu\text{g}\cdot\text{m}^{-3}$	<0.002 (*)	<0.002	4.1	<0.002	<0.002	<0.002	27
Benzo(b)fluoranthene	$\mu\text{g}\cdot\text{m}^{-3}$	<0.005	<0.005	5.5	<0.005	<0.005	<0.005	17
Phenanthrene	$\mu\text{g}\cdot\text{m}^{-3}$	<0.005	<0.005	2.9	<0.005	8.4	<0.005	no data
Fluoranthene	$\mu\text{g}\cdot\text{m}^{-3}$	<0.005	<0.005	3.6	<0.005	1.9	<0.005	120
Pyrene	$\mu\text{g}\cdot\text{m}^{-3}$	<0.005	<0.005	2.7	<0.005	1.7	<0.005	no data

(*) Maximum permissible value according to Polish regulations [35]. (*) Concentration below the quantification limit.

Special attention should be paid to the fact that no PAHs were detected in the samples collected during series 1. It should also be pointed out that the samples in series 1 were collected from the sedimentation/settling tank, whereas the samples in series 2 and 3 were collected directly from the Kołobrzaska collector. As shown in Figure 4, at the initial part of the pilot station, a mesh filter in the form of a protective basket with a mesh diameter of 5 mm was installed. Additionally, the station was equipped with an oblique mesh filter with a mesh diameter of 0.2 mm. Both filters were designed to retain solid particles (suspensions) and thus eliminate the risk of pump and flow meter failures. They also protected the pilot installation against clogging in the beds. It can therefore be assumed that certain amounts of polycyclic aromatic hydrocarbons might also be retained, together with solid particles (total suspended solids), which are hydrophobic compounds that are poorly soluble in water and have the ability to adsorb on the surfaces of suspension particles [48].

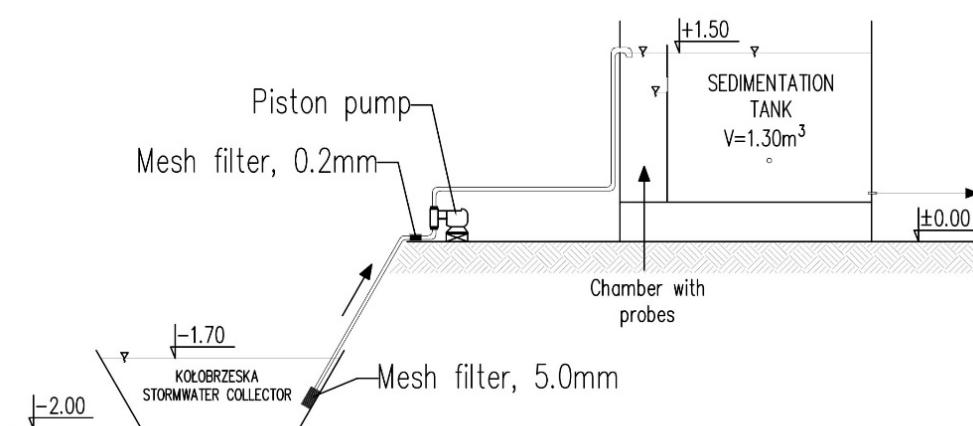

Figure 4. Diagram of the hydraulic system of the MCW pilot installation—part of the installation connecting the Kołobrzaska collector with the sedimentation tank.

As shown in Figure 5, in series 1, where the concentration of total suspended solids only amounted to $4.54 \text{ mg}\cdot\text{L}^{-1}$, no PAHs were detected (concentrations below the limit of quantification). In series 2, where the total suspended solids' concentration was as high as $72 \text{ mg}\cdot\text{L}^{-1}$, benzo(a)pyrene ($4.1 \text{ }\mu\text{g}\cdot\text{m}^{-3}$), benzo(b)fluoranthene ($5.5 \text{ }\mu\text{g}\cdot\text{m}^{-3}$), phenanthrene ($2.9 \text{ }\mu\text{g}\cdot\text{m}^{-3}$), fluoranthene ($3.6 \text{ }\mu\text{g}\cdot\text{m}^{-3}$) and pyrene ($2.7 \text{ }\mu\text{g}\cdot\text{m}^{-3}$) were detected. In series 3, at the concentration of total suspended solids equal to $12 \text{ mg}\cdot\text{L}^{-1}$, the presence of phenanthrene ($8.4 \text{ }\mu\text{g}\cdot\text{m}^{-3}$), fluoranthene ($1.9 \text{ }\mu\text{g}\cdot\text{m}^{-3}$) and pyrene ($1.7 \text{ }\mu\text{g}\cdot\text{m}^{-3}$) was confirmed. Therefore, a certain correlation between the concentration of total suspended solids and polycyclic aromatic hydrocarbons was observed. The higher the content of the suspensions in rainwater, the higher the concentration of individual PAHs in the tested samples. The exception was the phenanthrene concentration in series 3, which was higher with a lower concentration of suspension.

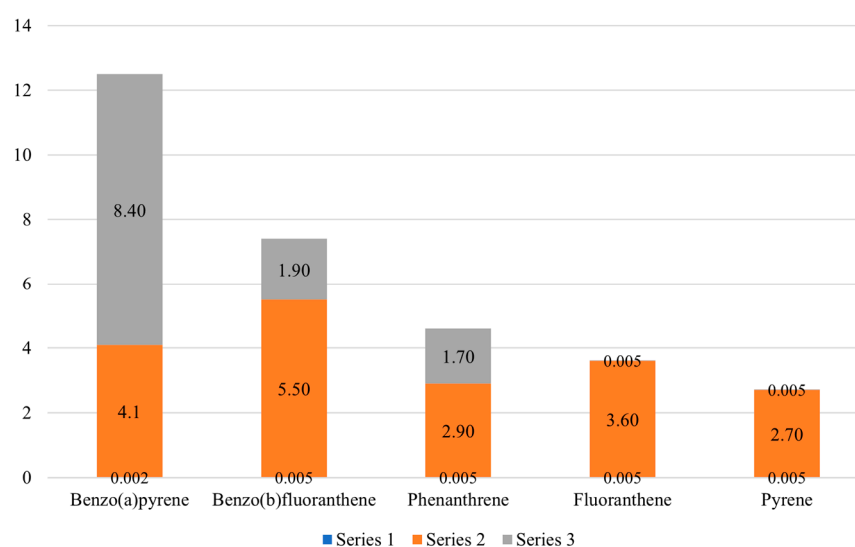

Figure 5. Fluctuations in the concentrations of PAHs in individual test series.

The conducted research has proven the very high effectiveness of PAHs removal using a multistage MCW pilot installation, which is presented in Table 5.

Table 5. Summary of research results, illustrating the effectiveness of polycyclic aromatic hydrocarbons' (PAHs) reduction in individual test series, expressed by MRR and η index (depending on the HLR).

	Series 2 07/05/2021–27/05/2021			Series 3 06/08/2021–26/08/2021		
	HLR $\text{mm}\cdot\text{d}^{-1}$	MRR $\mu\text{g}\cdot\text{m}^{-2}\cdot\text{d}^{-1}$	η (%)	HLR $\text{mm}\cdot\text{d}^{-1}$	MRR $\mu\text{g}\cdot\text{m}^{-2}\cdot\text{d}^{-1}$	η (%)
Benzo(a)pyrene	75.43	0.31	100	131.90	-	-
Benzo(b)fluoranthene	75.43	0.41	100	131.90	-	-
Phenanthrene	75.43	0.22	100	131.90	1.19	100
Fluoranthene	75.43	0.27	100	131.90	0.27	100
Pyrene	75.43	0.20	100	131.90	0.24	100

In series 2 of the conducted tests, the hydraulic load was $75.43 \text{ mm}\cdot\text{d}^{-1}$. A reduction in the concentrations of benzo(a)pyrene ($\text{MRR} = 0.31 \text{ }\mu\text{g}\cdot\text{m}^{-2}\cdot\text{d}^{-1}$), benzo(b)fluoranthene ($\text{MRR} = 0.41 \text{ }\mu\text{g}\cdot\text{m}^{-2}\cdot\text{d}^{-1}$), phenanthrene ($\text{MRR} = 0.22 \text{ }\mu\text{g}\cdot\text{m}^{-2}\cdot\text{d}^{-1}$), fluoranthene ($\text{MRR} = 0.27 \text{ }\mu\text{g}\cdot\text{m}^{-2}\cdot\text{d}^{-1}$) and pyrene ($\text{MRR} = 0.20 \text{ }\mu\text{g}\cdot\text{m}^{-2}\cdot\text{d}^{-1}$) was observed. In this series, the removal efficiency was 100%. In series 3, the hydraulic load was $131.90 \text{ mm}\cdot\text{d}^{-1}$,

and there was also a relatively high rate of reduction in phenanthrene ($\text{MRR} = 1.19 \mu\text{g}\cdot\text{m}^{-2}\cdot\text{d}^{-1}$), fluoranthene ($\text{MRR} = 0.27 \mu\text{g}\cdot\text{m}^{-2}\cdot\text{d}^{-1}$) and pyrene ($\text{MRR} = 0.24 \mu\text{g}\cdot\text{m}^{-2}\cdot\text{d}^{-1}$). Similar to series 2, the removal efficiency in series 3 was 100% for all mentioned substances.

3.3. Microplastics (MPs)

The pollution of the environment with microplastics is currently one of the major trends in research and analysis. In particular, an urgent issue is the detection and removal of MPs from water intended for human consumption, and the evaluation of the effectiveness of conventional wastewater treatment plants in eliminating MPs from wastewater. On the other hand, knowledge of microplastics is constantly growing. Therefore, scientific articles and literature reviews play an important role in organizing information about MPs, including origin, characteristics (i.e., particles sizes), impact on the environment and organisms, available removal techniques, and the efficiency of such solutions [49–52]. This study presents the preliminary research results related to the detection of microplastics and the effectiveness of their removal in a multistage wetland system. The test samples were collected on 15–16/10/2020 and 28–29/10/2020, from two points: (1) before treatment—from the sedimentation tank; (2) after treatment—from the purified water storage tank. As mentioned, the samples were taken with the filtration device UFO (Universal Filtering Object), purchased as a part of the FanPLESStic-sea project co-financed by the European Union under the Interreg Baltic Sea Region Programme 2014–2020.

Table 6 shows the test results for samples collected on 15–16/10/2020 (15/10/2020—sample from sedimentation tank, 16/10/2020—sample from treated water storage tank). Selected results of MPs determinations are presented, which concern only substances detected in rainwater at the Kołobrzaska collector, including polyethylene (PE), polypropylene (PP), polyester, polyamide (PA), acrylic, polyvinyl chloride (PVC), polystyrene (PS), polyurethane (PU) and alkyd. The occurrence of natural polymers such as cellulose and proteins (biopolymers) was not taken into account in further analyses. The concentrations of the determined MPs are expressed in $\mu\text{g}\cdot\text{m}^{-3}$.

Table 6. Microplastic concentration values (expressed in $\mu\text{g}\cdot\text{m}^{-3}$), measured at the inflow and outflow from the MCW pilot installation.

		PE	PP	Polyester	PA	Acrylic	PVC	PS	PU	Alkyd
C_{in}	$\mu\text{g}\cdot\text{m}^{-3}$	100.72	70.47	94.87	9.37	0.65	0.56	3.65	1.54	104.77
C_{out}	$\mu\text{g}\cdot\text{m}^{-3}$	3.17	0.45	23.61	0.84	0	0	0	0.08	0

The total concentration of microplastics (polymers) was $386.6 \mu\text{g}\cdot\text{m}^{-3}$. About 75% of all detected microplastic particles had a maximum (equivalent) diameter of 10–100 μm . Moreover, as much as 31% were particles with diameters of 26–50 μm . As shown in Tables 6 and 7, the largest weight share in the total mass of microplastics was represented by polyethylene, polypropylene, polyester and alkyd. The hydraulic load of the bed was $57.76 \text{ mm}\cdot\text{d}^{-1}$. The polyethylene concentration value at the inflow to the pilot station was $100.72 \mu\text{g}\cdot\text{m}^{-3}$, whereas at the outflow from the station it was $3.17 \mu\text{g}\cdot\text{m}^{-3}$. Therefore, the reduction was 97.11% and the MRR was equal to $5.65 \mu\text{g}\cdot\text{m}^{-2}\cdot\text{d}^{-1}$. The concentration of the polypropylene was $70.47 \mu\text{g}\cdot\text{m}^{-3}$ at the inflow. After the purification processes, its reduction to the value of $0.45 \mu\text{g}\cdot\text{m}^{-3}$ was observed. Thus, the reduction was 99.41%, while the MRR amounted to $4.05 \mu\text{g}\cdot\text{m}^{-2}\cdot\text{d}^{-1}$. A slightly lower reduction was achieved for polyester, from the value of $94.87 \mu\text{g}\cdot\text{m}^{-3}$ to $23.61 \mu\text{g}\cdot\text{m}^{-3}$ (77.16%, with an $\text{MRR} = 4.23 \mu\text{g}\cdot\text{m}^{-2}\cdot\text{d}^{-1}$). In the case of alkyd, the effectiveness was 100% and the MRR was equal to $6.05 \mu\text{g}\cdot\text{m}^{-2}\cdot\text{d}^{-1}$. Consequently, a reduction in concentration from the level of $104.77 \mu\text{g}\cdot\text{m}^{-3}$ to $0 \mu\text{g}\cdot\text{m}^{-3}$ was recorded.

Table 7. Summary of research results, illustrating the effectiveness of microplastics reduction, expressed by MRR and η index (depending on the HLR).

	HLR ($\text{mm} \cdot \text{d}^{-1}$)	MRR ($\mu\text{g} \cdot \text{m}^{-2} \cdot \text{d}^{-1}$)	η (%)
Polyethylene	57.76	5.65	97.11
Polypropylene	57.76	4.05	99.41
Polyester	57.76	4.23	77.16
Polyamide	57.76	0.50	91.77
Acrylic	57.76	0.04	100.00
Polyvinyl chloride	57.76	0.03	100.00
Polystyrene	57.76	0.21	100.00
Polyurethane	57.76	0.08	95.23
Alkyd	57.76	6.05	100.00

4. Conclusions

Our study showed that rainwater surface runoff from the urbanized catchment was characterized by a variable load of specific pollutants, including priority substances and emerging pollutants. Particularly important are the increased concentrations of zinc and copper, the limit values of which (dangerous to organisms) are not fully understood. The mercury concentrations also exceeded the acceptable thresholds, which is worrying. The concentrations of polycyclic aromatic hydrocarbons did not exceed the permissible national limit values. However, the observations show that with an increase in the concentration of total suspended solids in rainwater, there is a potential risk of an increase in the concentration of polycyclic aromatic hydrocarbons. This is most likely due to their hydrophobicity and ability to adsorb on the surface of solid particles. The observed concentrations of microplastics in rainwater were significant (the total value was $386.6 \mu\text{g} \cdot \text{m}^{-3}$). Considering how important this issue is, further observations and research should be undertaken, especially in terms of the material composition of microplastics, the origin, and the size of the particles, but also their capacity for adsorption or sorption in porous media, accumulation in sediments, and bioaccumulation in the tissues and organs of animals and plants.

Multistage constructed wetland systems (MCWs) enable the partial or complete removal of specific substances and emerging pollutants, which has been demonstrated by this research. Depending on the hydraulic load of the bed, the reduction efficiency ranged from 26.19% to 100% for heavy metals (while the most optimal conditions were observed for the hydraulic load of $75.43 \text{ mm} \cdot \text{d}^{-1}$), from 77.16 to 100% for microplastics, and reached 100% for polycyclic aromatic hydrocarbons. An increase in Zn, Cu and Pb concentrations was also observed after the purification process, which may be caused by the phenomenon of suffosion, i.e., the washing out of these elements from the beds. However, further observations are required to clearly identify the factors that may have contributed to the increases in Zn, Cu and Pb concentrations, taking into account a greater number of repeatable test results and additional aspects such as the flow rate or the occurrence of rainfall, especially torrential rainfall.

Further observations are required related to the changes in the values of zinc and cadmium concentrations after subsequent stages of treatment in a multistage wetland system.

Attaining high efficiency in the removal of heavy metals, polycyclic aromatic hydrocarbons and microplastics using a multistage wetland system also requires further investigation into the processes that contribute to reductions in these substances, i.e., sorption and bioaccumulation.

At the moment, there are no regulations or legislation regarding the limit values of microplastics, nor standardized test methods for these substances. Therefore, all the mentioned factors make it difficult to assess the scale of this important ecological problem.

Author Contributions: Conceptualization, P.J., M.D., M.G. and K.F.; formal analysis, P.J. and M.D.; investigation, P.J.; resources, M.D.; writing—original draft preparation, P.J. and K.F.; writing—review and editing, P.J. and K.F.; supervision, M.G.; project administration, M.D. All authors have read and agreed to the published version of the manuscript.

Funding: Part of the research was conducted within the FanPLESStic-sea Project, co-funded by the European Union (European Regional Development Fund) under the Interreg Baltic Sea Region Programme 2014–2020; Project number: #R092.

Institutional Review Board Statement: Not applicable.

Informed Consent Statement: Not applicable.

Data Availability Statement: Data available on request.

Acknowledgments: The authors gratefully acknowledge the sample preparation for microplastic analysis performed by the Latvian Institute of Aquatic Ecology, and the final microplastic analysis conducted by the Aalborg University, in the range of the FanPLESStic-sea Project.

Conflicts of Interest: The authors declare no conflict of interest.

References

1. Act of 20 July 2017. *Water Law*; Journal of Laws of the Republic of Poland: Warsaw, Poland, 2017; Item 1566.
2. Directive 2000/60/EC of the European Parliament and of the Council of 23 October 2000 Establishing a Framework for Community Action in the Field of Water Policy. Available online: <https://eur-lex.europa.eu/legal-content/en/ALL/?uri=CELEX%3A32000L0060> (accessed on 8 January 2022).
3. Wiest, L.; Baudot, R.; Lafay, F.; Bonjour, E.; Becouze-Lareure, C.; Aubin, J.-B.; Jame, P.; Barraud, S.; Lipeme Kouyi, G.; Sébastien, C.; et al. Priority substances in accumulated sediments in a stormwater detention basin from an industrial area. *Environ. Pollut.* **2018**, *243*, 1669–1678. [CrossRef]
4. Müller, A.; Österlund, H.; Marsalek, J.; Viklander, M. The pollution conveyed by urban runoff: A review of sources. *Sci. Total Environ.* **2020**, *709*, 136125. [CrossRef] [PubMed]
5. Wicke, D.; Matzinger, A.; Sonnenberg, H.; Caradot, N.; Schubert, R.-L.; Dick, R.; Heinzmann, B.; Dünnbier, U.; von Seggern, D.; Rouault, P. Micropollutants in Urban Stormwater Runoff of Different Land Uses. *Water* **2021**, *13*, 1312. [CrossRef]
6. Zgheib, S.; Moilleron, R.; Saad, M.; Chebbo, G. Partition of pollution between dissolved and particulate phases: What about emerging substances in urban stormwater catchments? *Water Res.* **2011**, *45*, 913–925. [CrossRef] [PubMed]
7. Osuch-Pajdzińska, E.; Roman, M. *Sieci I Obiekty Wodociągowe*, 2nd ed.; Publishing House of Warsaw University of Technology: Warsaw, Poland, 2015; p. 43.
8. Statistics Poland. Environment. 2020. Available online: <https://stat.gov.pl> (accessed on 5 October 2021).
9. Gutry-Korycka, M.; Sadurski, A.; Kundzewicz, Z.W.; Pociask-Karteczka, J.; Skrzypczyk, L. Zasoby wodne a ich wykorzystanie. *NAUKA* **2014**, *1*, 77–98.
10. Bogusz, A.; Tokarczyk, T. Rola terenów zalesionych w kształtowaniu retencji wód opadowych w zlewniach zurbanizowanych. In *Hydrologia Zlewni Zurbanizowanych*; Hejduk, L., Kaznowska, E., Eds.; Monographs of Water Management Committee of Polish Academy of Sciences: Warsaw, Poland, 2016; Issue 39, pp. 253–264.
11. Tian, S.; Wang, Z.; Shang, H. Study on the Self-purification of Juma River. *Procedia Environ. Sci.* **2011**, *11*, 1328–1333. [CrossRef]
12. Zgheib, S.; Moilleron, R.; Chebbo, G. Priority pollutants in urban stormwater: Part 1—Case of separate storm sewers. *Water Res.* **2012**, *46*, 6683–6692. [CrossRef]
13. Göbel, P.; Dierkes, C.; Coldewey, W.G. Storm water runoff concentration matrix for urban areas. *J. Contam. Hydrol.* **2007**, *91*, 26–42. [CrossRef] [PubMed]
14. Ingvertsen, S.T.; Jensen, M.B.; Magid, J. A minimum data set of water quality parameters to assess and compare treatment efficiency of stormwater facilities. *J. Environ. Qual.* **2011**, *40*, 1488–1502. [CrossRef] [PubMed]
15. Pistocchi, A.; Calzolari, C.; Malucelli, F.; Ungaro, F. Soil sealing and flood risk in the plains of Emilia-Romagna, Italy. *J. Hydrol. Reg. Stud.* **2015**, *4*, 398–409. [CrossRef]
16. Borowiec, N.; Hamerla, A. Comparison of sealing surface degree assessment based on orthophotomap and lidar data. *J. Sustain. Min.* **2013**, *12*, 20–26. [CrossRef]
17. Uchiyama, R.; Okochi, H.; Katsumi, N.; Ogata, H. The impact of air pollutants on rainwater chemistry during “urban-induced heavy rainfall” in downtown Tokyo, Japan. *J. Geophys. Res. Atmos.* **2017**, *122*, 6502–6519. [CrossRef]
18. Gajewska, M. Złoża hydrofitowe z pionowym przepływem ścieków. Charakterystyka procesów i zastosowań. In *Monographs of Environmental Engineering Committee of Polish Academy of Sciences*; Pawłowski, L., Ed.; Polish Academy of Sciences: Warsaw, Poland, 2019; Volume 150, pp. 186–187.
19. Kolendowicz, L.; Bednorz, E.; Walna, B.; Kurzyca, I. Episodes of extreme rainwater pollution and its relationship with synoptic situation (Wielkopolski National Park, Poland). *J. Atmos. Chem.* **2011**, *68*, 89–105. [CrossRef]

20. Murphy, L.U.; O'Sullivan, A.; Cochrane, T.A. Quantifying the spatial variability of airborne pollutants to stormwater runoff in different land-use catchments. *Water Air Soil Pollut.* **2016**, *225*, 1–13. [CrossRef]
21. Aryal, R.; Vigneswaran, S.; Kandasamy, J.; Naidu, R. Urban stormwater quality and treatment. *Korean J. Chem. Eng.* **2010**, *27*, 1343–1359. [CrossRef]
22. Tang, Y.; Yin, M.; Yang, W.; Li, H.; Zhong, Y.; Mo, L.; Liang, Y.; Ma, X.; Sun, X. Emerging pollutants in water environment: Occurrence, monitoring, fate, and risk assessment. *Water Environ. Res.* **2019**, *91*, 984–991. [CrossRef]
23. Bunke, D.; Moritz, S.; Brack, W.; Herráez, D.L.; Posthuma, L.; Nuss, M. Developments in society and implications for emerging pollutants in the aquatic environment. *Environ. Sci. Eur.* **2019**, *31*, 1–17. [CrossRef]
24. Fairbairn, D.J.; Elliott, S.M.; Kiesling, R.L.; Schoenfuss, H.L.; Ferrey, M.L.; Westerhoff, B.M. Contaminants of emerging concern in urban stormwater: Spatiotemporal patterns and removal by iron-enhanced sand filters (IESFs). *Water Res.* **2018**, *145*, 332–345. [CrossRef] [PubMed]
25. Masoner, J.R.; Kolpin, D.W.; Cozzarelli, I.M.; Barber, L.B.; Burden, D.S.; Foreman, W.T.; Forshay, K.J.; Furlong, E.T.; Groves, J.F.; Hladik, M.L.; et al. Urban Stormwater: An Overlooked Pathway of Extensive Mixed Contaminants to Surface and Groundwaters in the United States. *Environ. Sci. Technol.* **2019**, *53*, 10070–10081. [CrossRef]
26. Kowalczyk, A. *Formowanie Sieć Zasobów Wód Podziemnych W Utworach Węglanowych Triasu Śląsko-Krakowskiego W Warunkach Antropopresji*; University of Silesia Press: Katowice, Poland, 2003; pp. 19–20.
27. Baltic Marine Environment Protection Commission. Helcom Recommendation 23/5: Reduction of Discharges from Urban Areas by the Proper Management of Storm Water System. Rev.1. Available online: <https://helcom.fi/wp-content/uploads/2021/06/Rec-23-5-Rev.1.pdf> (accessed on 8 January 2022).
28. Gizińska-Górna, M. Reliability and Efficiency of Pollutant Removal in Four-Stage Constructed Wetland of SSVF-SSHF-SSHF-SSVF Type. *Water* **2020**, *12*, 3153. [CrossRef]
29. Kadlec, R.H.; Reddy, K.R. Temperature effects in treatment wetlands. *Water Environ. Res.* **2001**, *73*, 543–557. [CrossRef]
30. Kadlec, R.H.; Wallace, S.D. *Treatment Wetlands*, 2nd ed.; CRC Press: Boca Raton, FL, USA, 2009; pp. 21–22.
31. Politeo, M.; Borin, M.; Milani, M.; Toscano, A.; Molari, G. Production and energy value of phragmites australis obtained from two constructed wetlands. In Proceedings of the 19th European Biomass Conference and Exhibition, Berlin, Germany, 6–10 June 2011.
32. Kadlec, R.H.; Knight, R.L.; Vymazal, J.; Brix, H.; Cooper, P.; Haberl, R. Constructed wetlands for pollution control. Processes, performance, design and operation. In *IWA Specialist Group on Use of Macrophytes in Water Pollution Control*; IWA Publishing: London, UK, 2000; pp. 91–92.
33. Garcia-Avila, F. Treatment of municipal wastewater by vertical subsurface flow constructed wetland: Data collection on removal efficiency using Phragmites Australis and Cyperus Papyrus. *Data Brief* **2020**, *30*, 105584. [CrossRef] [PubMed]
34. Municipality of the City of Gdańsk. In *Public Information Bulletin*; Gdańsk City Hall: Gdańsk, Poland, 2020; Available online: <https://bip.gdansk.pl/urząd-miejski/podział-administracyjny-gdanska,a,647> (accessed on 24 October 2021).
35. *Regulation of the Minister of Maritime Economy and Inland Navigation of 25 June 2021 on the Classification of Ecological Status, Ecological Potential and Chemical Status and the Method of Classification of the State of Surface Water Bodies, as Well as Environmental Quality Standards for Priority Substances*; Journal of Laws of the Republic of Poland: Warsaw, Poland, 2021; Item 1475.
36. Chelmiński, W. *Woda. Zasoby, Degradacja, Ochrona*, 1st ed.; Polish Scientific Publishers PWN: Warszawa, Poland, 2012; p. 32.
37. Żurek, G.; Majtkowski, W. Alternative plant species in phytoremediation of heavy metals from polluted land. *Probl. Agric. Eng.* **2009**, *17*, 83–89.
38. Łukowski, A.; Wiater, J.; Dymko, A. Bioaccumulation of heavy metals in forage grasses. *J. Ecol. Eng.* **2017**, *18*, 149–158. [CrossRef]
39. Naito, W.; Kamo, M.; Tsushima, K.; Iwasaki, Y. Exposure and risk assessment of zinc in Japanese surface waters. *Sci. Total Environ.* **2010**, *408*, 4271–4284. [CrossRef] [PubMed]
40. Itahashi, S.; Kasuya, M.; Suzuki, R.; Abe, K.; Banzai, K. Assessment of potential risk to aquatic organisms by zinc originating from swine farm effluent in a rural area of Japan. *Jpn. Agric. Res. Q. JARQ* **2014**, *48*, 291–298. [CrossRef]
41. Makepeace, D.K.; Smith, D.W.; Stanley, S.J. Urban stormwater quality: Summary of contaminant data. *Crit. Rev. Environ. Sci. Technol.* **1995**, *25*, 93–139. [CrossRef]
42. Golding, S. Suggested practices to reduce zinc concentrations in industrial stormwater discharges. In *Water Quality Program Washington State Department of Ecology. Environmental Assessment Program for Water Quality Program*; Olympia: Washington, DC, USA, 2008; pp. 1–34.
43. Charters, F.J.; Cochrane, T.A.; O'Sullivan, A.D. Characterising urban zinc generation to identify surface pollutant hotspots in a low intensity rainfall climate. *Water Sci. Technol.* **2017**, *76*, 1370–1377. [CrossRef]
44. Pohl, A.; Kostecki, M.; Jureczko, I.; Czaplicka, M.; Łozowski, B. Polycyclic aromatic hydrocarbons in water and bottom sediments of a shallow, lowland dammed reservoir (on the example of the reservoir Blachownia, South Poland). *Arch. Environ. Prot.* **2018**, *44*, 10–23. [CrossRef]
45. Ohura, T.; Amagai, T.; Fusaya, M.; Matsushita, H. Spatial distributions and profiles of atmospheric polycyclic aromatic hydrocarbons in two industrial cities in Japan. *Environ. Sci. Technol.* **2004**, *38*, 49–55. [CrossRef] [PubMed]
46. Mandalakis, M.; Tsapakis, M.; Tsoga, A.; Stephanou, E.G. Gas-particle concentrations and distribution of aliphatic hydrocarbons, PAHs, PCBs and PCDD/Fs in the Atmosphere of Athens (Greece). *Atmos. Environ.* **2002**, *36*, 4023–4035. [CrossRef]

47. Al Ali, S.; Debade, X.; Chebbo, G.; Béchet, B.; Bonhomme, C. Contribution of atmospheric dry deposition to stormwater loads for PAHs and trace metals in a small and highly trafficked urban road catchment. *Environ. Sci. Pollut. Res.* **2017**, *24*, 26497–26512. [[CrossRef](#)]
48. Burmistrz, M.; Burmistrz, P. Distribution of polycyclic aromatic hydrocarbons in coke plant wastewater. *Water Sci. Technol.* **2013**, *68*, 2414–2420. [[CrossRef](#)] [[PubMed](#)]
49. Wang, Z.; Lin, T.; Chen, W. Occurrence and removal of microplastics in an advanced drinking water treatment plant (ADWTP). *Sci. Total Environ.* **2020**, *700*, 134520. [[CrossRef](#)]
50. Talvitie, J.; Mikola, A.; Koistinen, A.; Setälä, O. Solutions to microplastic pollution—Removal of microplastics from wastewater effluent with advanced wastewater treatment technologies. *Water Res.* **2017**, *123*, 401–407. [[CrossRef](#)] [[PubMed](#)]
51. Padervand, M.; Lichtfouse, E.; Robert, D.; Wang, C. Removal of microplastics from the environment: A review. *Environ. Chem. Lett.* **2020**, *18*, 807–828. [[CrossRef](#)]
52. Liu, W.; Zhang, J.; Liu, H.; Guo, X.; Zhang, X.; Yao, X.; Cao, Z.; Zhang, T. A review of the removal of microplastics in global wastewater treatment plants: Characteristics and mechanisms. *Environ. Int.* **2021**, *146*, 106277. [[CrossRef](#)]